

DUST FILTRATION DUST FILTER

SILOTOP® polyTUBE™

Silo Venting Filters

DISTRIBUTED BY



SERVICE & SUPPORT

Wangara, WA +61 8 9413 1100
support@inquip.com.au
inquip.com.au

INTERNATIONAL PATENTS

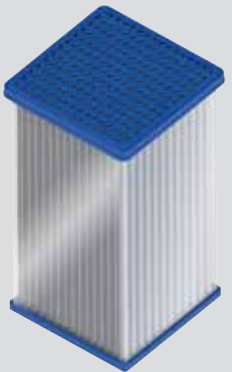

polyTUBE



MECHANICAL CLEANING SYSTEM

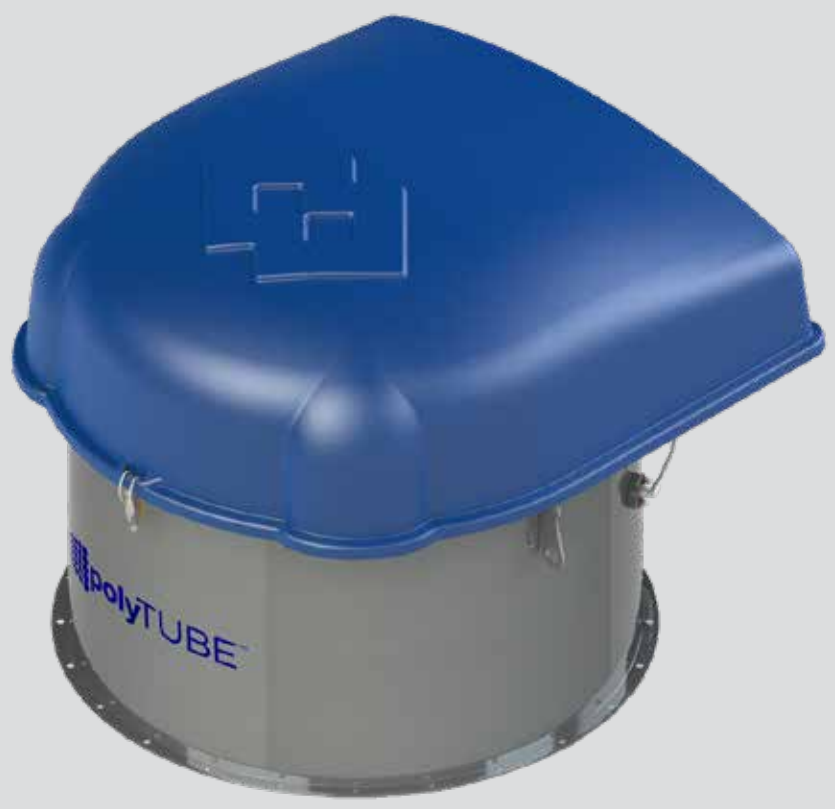

INNOVATIVE DUST FILTRATION TECHNOLOGY FOR A CLEAN, SAFE & HEALTHY ENVIRONMENT

SILOTOP® polyTUBE™ is a specialised compact silo venting filter designed for application in concrete plants. Its stainless-steel housing contains vertically mounted polyTUBE™ filter elements.

polyTUBE™ filtration technology ensures high filtration efficiency thanks to **zero** nano-fibre media and an open-profile tubular cell structure for reduced dust residue and high performance over time.

The mechanical cleaning system is electrically activated and mounted on the energy distribution frame to provide efficient cleaning even during silo filling.

SILOTOP® polyTUBE™ enables rapid evacuation of the dust-laden air flow to keep the silo system at peak performance.

The dust separated from the air flow by special filter elements drops back into the silo after an automatic mechanical cleaning system has removed the dust from the filter media.

polyTUBE™ technology offers maximum filtration performance with minimum energy consumption.



The use of **compressed air** can be a challenge in a concrete plant due to:

- ☹️ Moisture
- ☹️ Low temperature
- ☹️ Condensation
- ☹️ Increased operating costs
- ☹️ Safety and operational issues

polyTUBE™ technology offers top performance without compressed air and is:

- 🟩 **ENERGY**-saving
- 🟩 **TIME**-saving
- 🟩 **SPACE**-saving
- 🟩 **MONEY**-saving



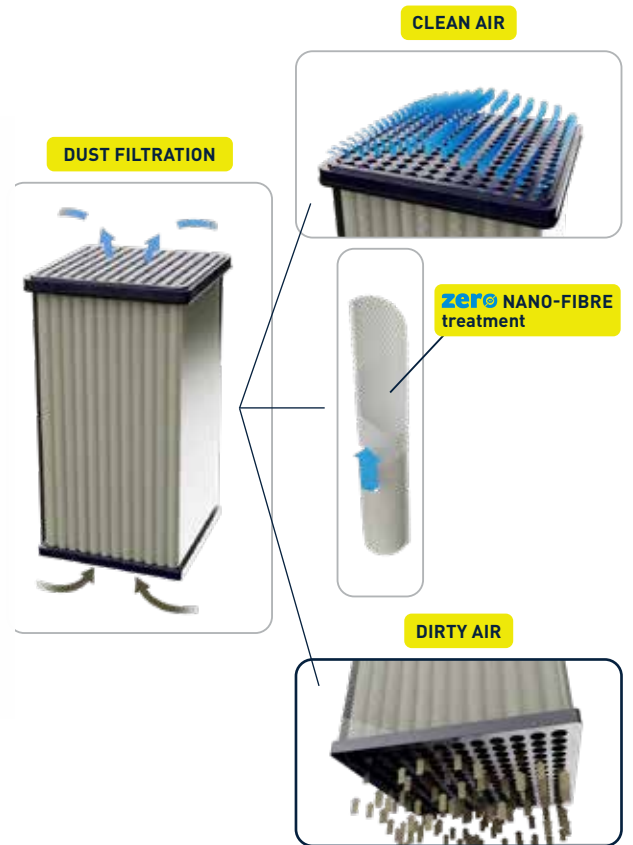
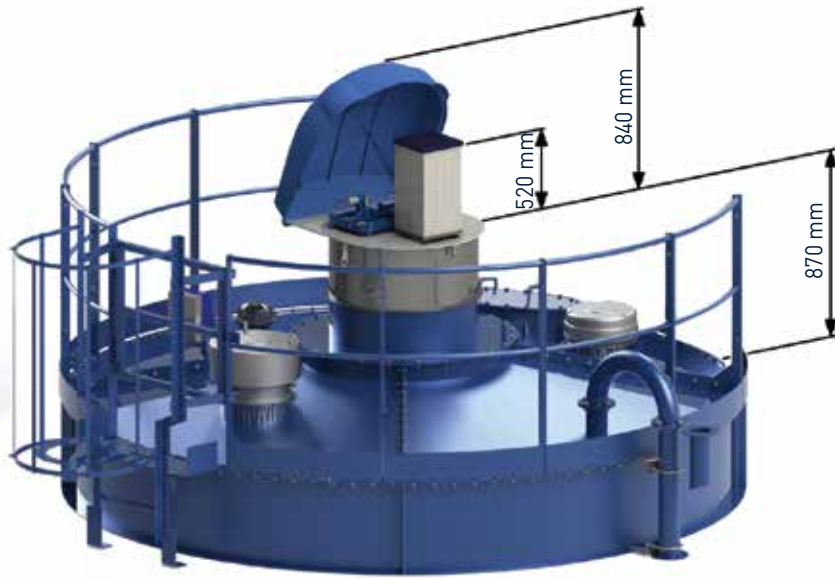

....enhancing EFFICIENCY and SAFETY!

COMPACT DESIGN





 polyTUBE™



-  polyTUBE™ performs 4 times more efficiently than conventional filter elements
-  High durability due to tubular cell structure
-  Eco-friendly **zero** filter media (<math><1\text{mg}/\text{Nm}^3</math> dust emission)
-  Sturdy yet lightweight

MECHANICAL CLEANING SYSTEM



-  Low energy consumption
-  3 times lower noise level than air pulse-jet cleaning
-  Maximum performance at minimum stress on filter media

FILMEC™ Electronic Controller



Fully automated function management and control with work-step recording

 Plug&Play

 Differential Pressure Meter

 Modbus RS485

 Monitoring Diagram

Power Supply	Frequency (Hz)	Maximum Current (A)	Maximum Power (W)	Energy Consumption (Wh)
90/260 V (AC)	50/60	5	100	<10

Performance during silo filling (test duration: 24 minutes)

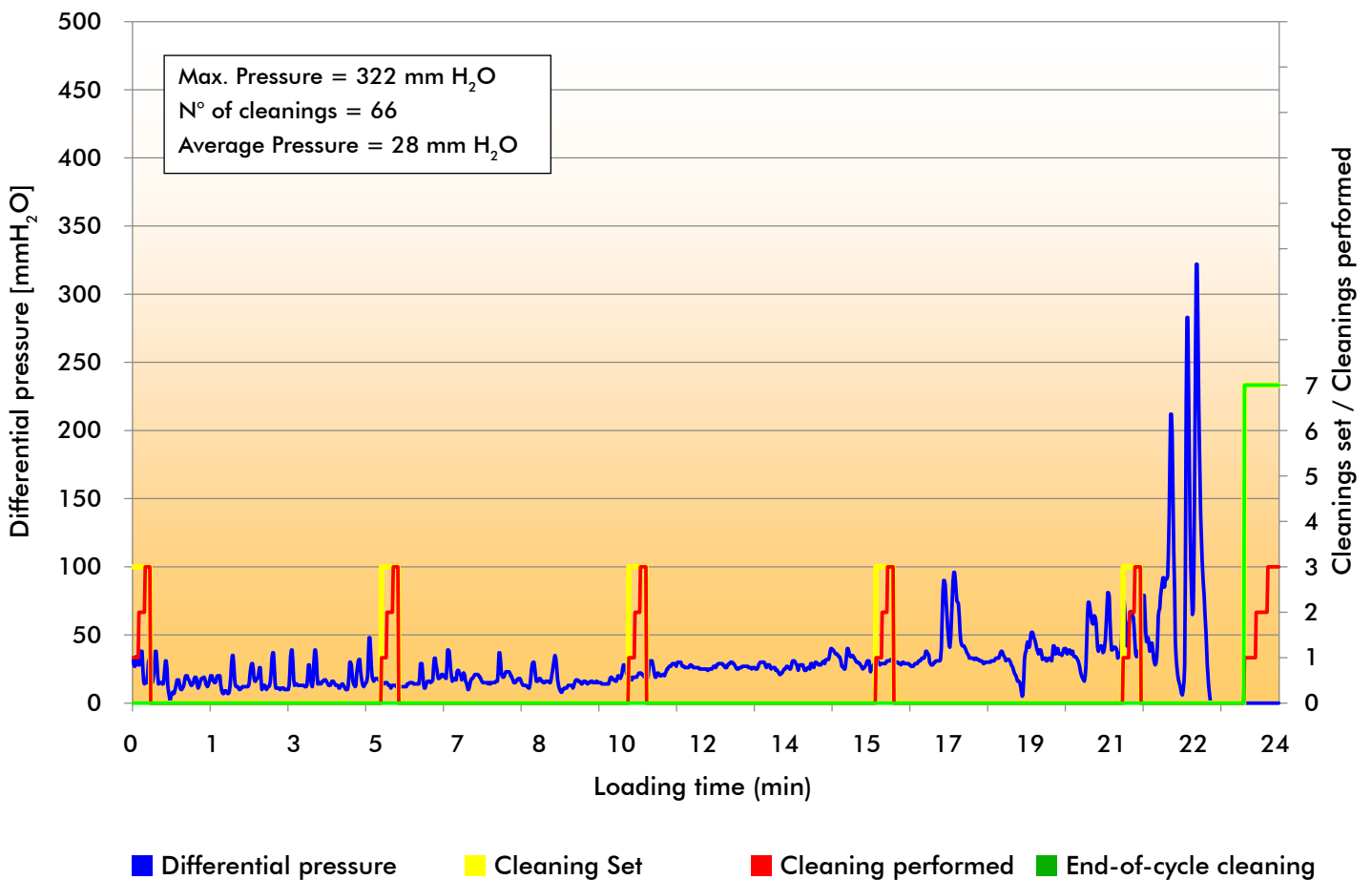

Benefits



Minimum dust emissions
(less than 1mg/Nm³ with cement)



Reduced noise (3 x lower noise than pneumatic cleaning) [-9 dB(A)]



Minimised energy consumption
< 80 kWh/year



Safe plant thanks to low differential pressure and data monitoring



Lower installation and operating costs



Maximum performance over time without dust residue

Overall Dimensions

INTERCHANGEABLE with all previous SILOTOP® versions

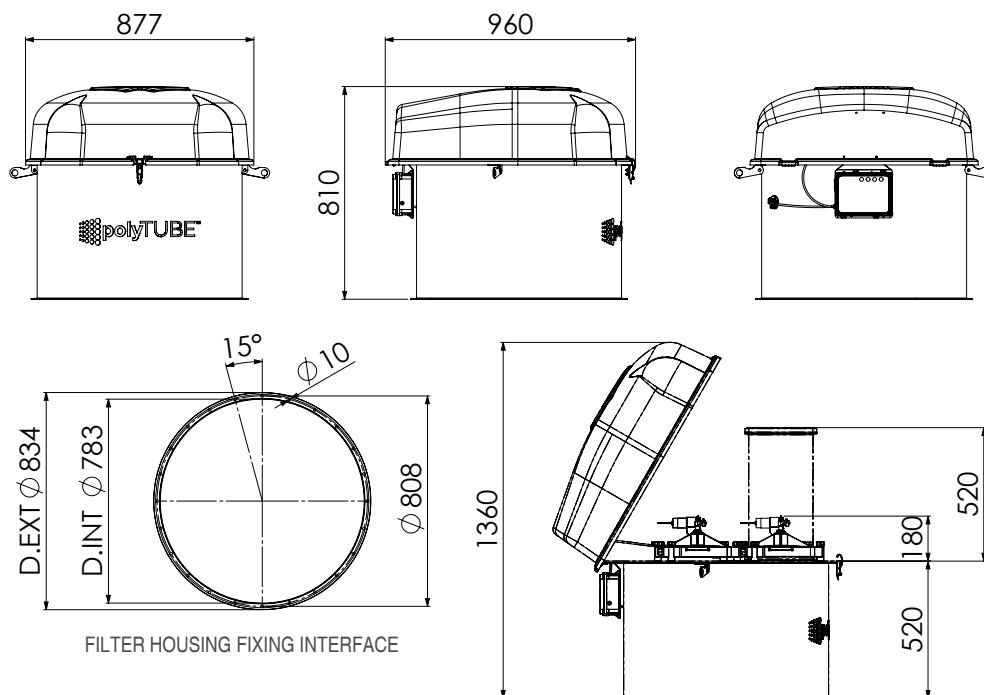

TYPE	NOMINAL AIR FLOW* (Nm ³ /h)	HOUSING Ø (mm)	MAX. HEIGHT (mm)		WEIGHT (kg)
			closed	open	
SILOPT1500	1,500 *	800	810	1,360	60

* when conveying dust up to 1,000 m³/h (peaks of 1500 m³/h), when cleaning tanker pipes up to 2,600 m³/h

Accessories

- Weld-on bottom ring



- Emission sampling kit



Application



Shaping a greener future



203001825 May 2024. Rights reserved to modify technical specifications.

This brochure has been edited for distribution in European Union countries.



UNI EN ISO 9001
Certified Company



UNI EN ISO 14001
Certified Company

www.wamgroup.com