

IMScompact integrated measuring system

for ball rail systems BSHP

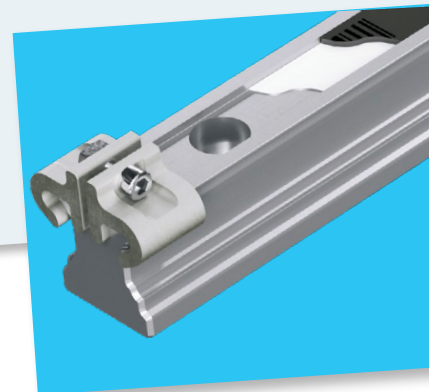
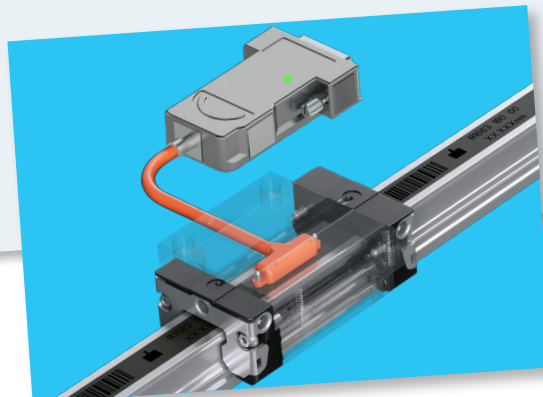
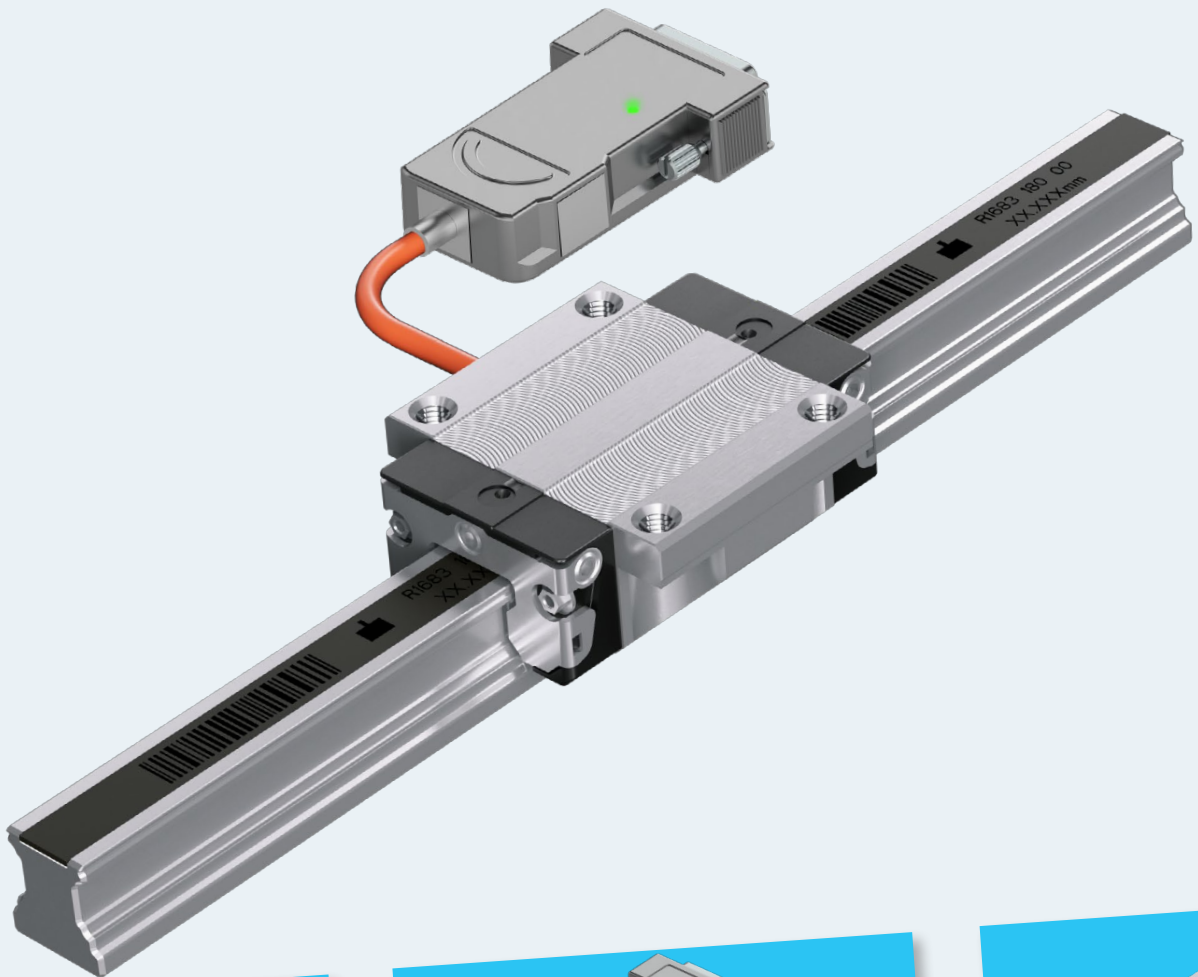

Contents

Contents	3	Ball guide rail for IMScompact	32
		Product overview and type key, ball guide rails	32
		Ball guide rail for IMScompact	33
Product overview	4	Accessories	34
At a glance	5	Cables and electrical accessories	34
Product description	6	Filter connector	35
Your benefits	8	Magnetic strips	35
Applications in automation	9	Pole search film	35
		Cover strip	36
		Strip clamps	36
		Mechanical accessories	37
		Position display	37
Technical data	10	Further information	38
Dimensioning and calculations	10	Safety instructions	38
IMScompact runner block	11	Configurators, calculation tools, eShop, CAD models	40
Cables and connectors	17	Bosch Rexroth Linear Motion Technology homepage	41
Connectors and assignment	18	Configurators and tools	41
Magnetic strip	20	GoTo Europe	42
IMScompact guide rail	23	How-to: Linear Motion Technology	42
Accuracy	23	Service	43
		Training	43
Ball runner block for IMScompact	24		
Product overview and type key	24		
FNS (Flanged, normal, standard height)	26		
FLS (Flanged, long, standard height)	27		
SNS (Slimline, normal, standard height)	28		
SLS (Slimline, long, standard height)	29		
SNH (Slimline, normal, high)	30		
SLH (Slimline, long, high)	31		

Product overview

With the new integrated, magnetic measuring system "IMScompact", Rexroth expands their product range of integrated measuring systems and thus opens up an extended area of application for linear position measurement systems.

With minimal spatial requirements, i.e. the new size 15, a maximum measuring length of up to 17.8 meters across rail joints, with incremental and absolute interfaces as well as with a simplified structural design, the new IMScompact series supplements the highly precise IMS inductive measuring system. It is applied in a wide variety of fields in automation technology, wood and plastics processing, sheet metal working, linear direct drive technology and general mechanical engineering.

The proven Rexroth quality characteristics of interchangeable design, modularity, robustness and easy assembly were consistently continued here. In connection with superior logistics, the global distribution and service, the customer will benefit from simplified work across the entire value adding chain from structural design, purchasing and logistics to assembly and maintenance.

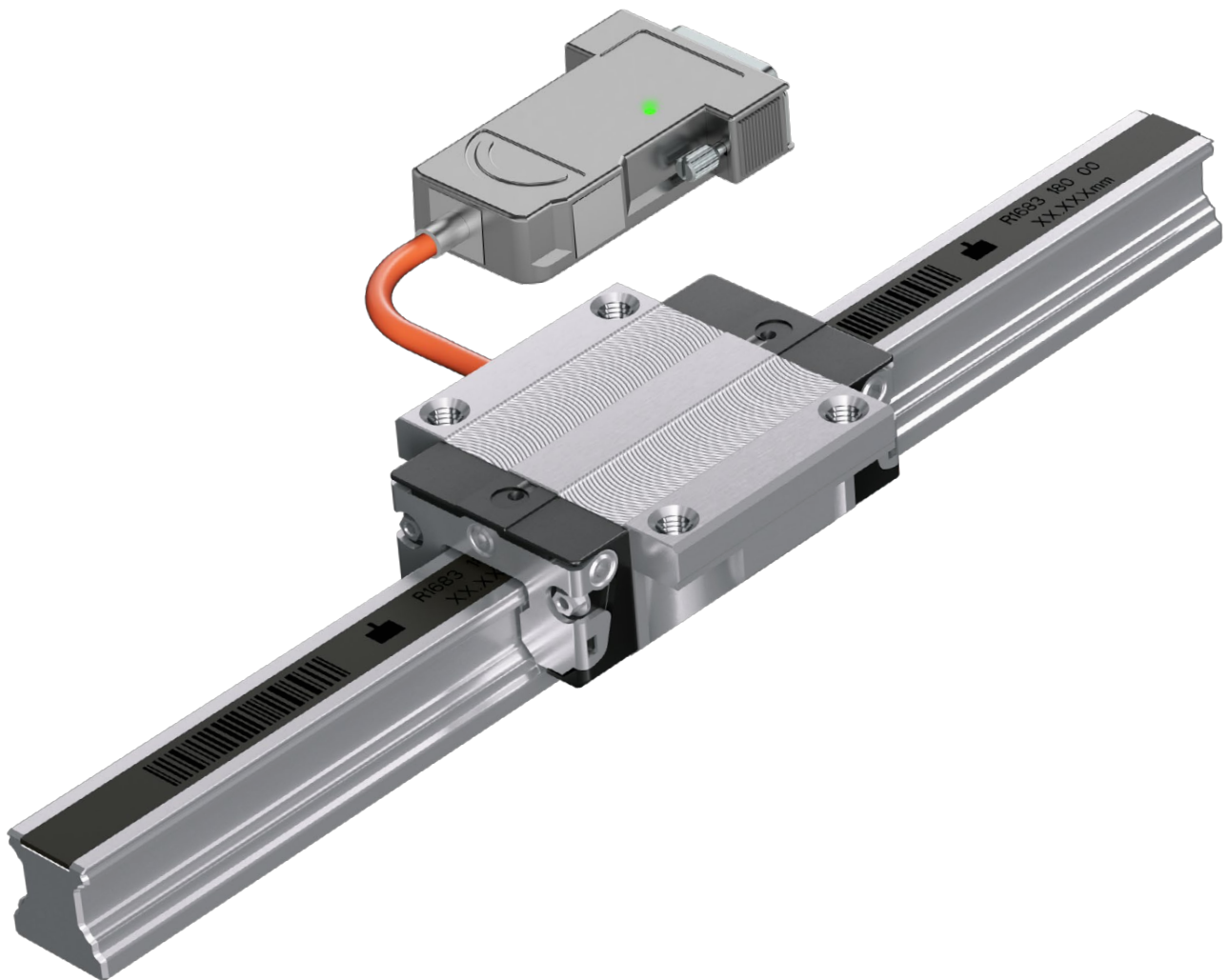

At a glance

- Compact**
- ▶ Construction-space neutral, integrated scanner electronics
 - ▶ Sizes 15, 20, and 25 in six runner block designs
 - ▶ Runner block accessible from all sides (lubrication, cleaning)
- Flexible**
- ▶ Magnetic strip can be installed across rail joints
 - ▶ Length finishing with manual tools
 - ▶ Any magnetic strip and rail size can be combined with any electrical interface
 - ▶ Compatible with the full BSHP product range
 - ▶ Compatible with the braking and clamping units, bellows, front seals and front lube units
 - ▶ Lateral cable output in all directions
- Robust**
- ▶ Protection class IP67 without buffer air and encapsulation
 - ▶ Dirt-resistant magnetic measuring principle
 - ▶ Recirculating seals for protection against dirt and media
 - ▶ Sensors shielded by steel bodies, no interference from external magnetic fields (e.g. linear motor)
 - ▶ Measurement close to and stiff at the tool center point
 - ▶ Optional clip cover strip
- Cost-effective**
- ▶ Mount & Guide & Measure: fully adjusted Plug & Play complete system
 - ▶ Favorable component price
 - ▶ No additional assembly or disposition required
- Future-proof**
- ▶ Global service and spare parts from the BSHP building system
 - ▶ Compatible with all established drive controllers and measuring displays
 - ▶ Easy replacement
- Powerful**
- | | |
|-------------------|---|
| Repeatability: | ±1 µm |
| System accuracy: | ±20 µm/m |
| Voltage supply: | 10 ... 30VDC |
| Incremental: | 1Vss (1 mm) and TTL (10 µm) reference track, pitch-coded |
| Absolute: | SSI (10µm) with 1Vss (1mm), combination encoder interface |
| Highly dynamic: | up to 5 m/s |
| Measuring length: | up to 17.8 m |

Several scanners on one rail possible

Encoders and other interfaces which are suitable for drive-integrated safety technology are currently being prepared.

Product description

Ball runner block with integrated measuring sensor

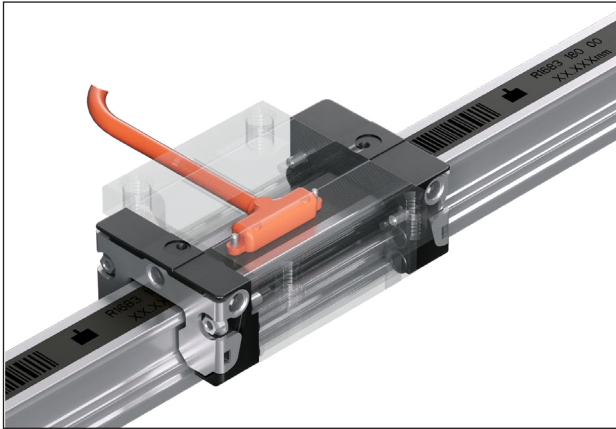

- ▶ The runner block and the measuring sensor form a compact, completely assembled unit.
- ▶ The runner block is fully loadable up to F_{max} and compatible with the Rexroth interchangeable design. With the integrated seals and the massive steel shield, the electronics are optimally protected.

Ball guide rail with slot for magnetic strip



- ▶ Ball guide rails secured with screws from above, with a slot for the intake of the magnetic strip.
- ▶ BSHP interchangeability
- ▶ Available in one-piece and multi-piece butted versions for measuring lengths up to max. 17.8 meters.

Rexroth magnetic strip

- ▶ Peel of protection film – glue in – finished.
The magnetic strips are attached to a thermally stable stainless-steel frame and equipped with transfer adhesive tape.
- ▶ At the same time, it serves as closure for the fastening bore holes.
- ▶ Any of the three magnetic strip sizes can be combined with any electrical interface.

Wide range of accessory products

- ▶ The complete BSHP range is compatible: from additional ball runner blocks to clamping units, additional seals to lubrication elements and bellows.
[Link BSHP catalog](#)
- ▶ Additionally, drives, linear motors, controllers and control systems as well as position indicators by Rexroth are available.

Your benefits

Compact machine design

Space requirement for external length measuring system is eliminated

1. Linear guide
2. Linear encoder
3. IMScompact integrated measuring system
4. Savings in installation space

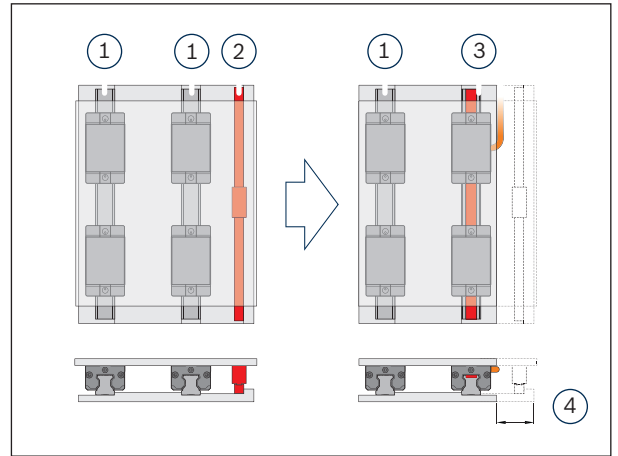

From structural design to service

IMScompact offers a high degree of cost-effectiveness that extends over the entire life cycle. From engineering to assembly and commissioning through to maintenance and service.

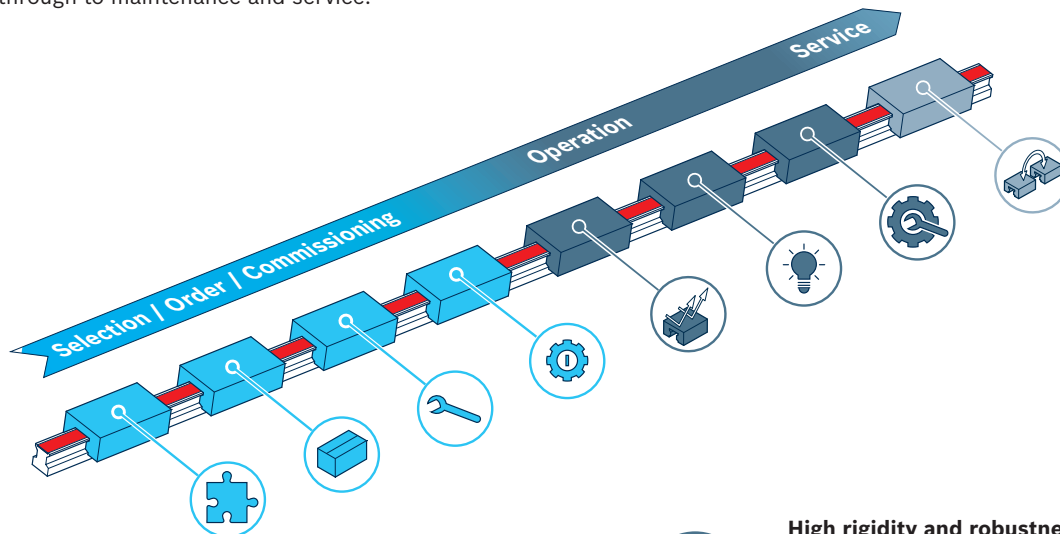

Simplified structural design
Fewer components, less installation space

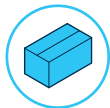

Simplified scheduling and logistics
Fewer components



Simplified assembly
One mounting step – profiled rail system contains the complete measuring technology



Simplified commissioning
Guided system – no alignment of the scale and no adjustment of the scanner over the measuring distance necessary



High rigidity and robustness

- ▶ Position measurement directly at the movement and protected installation of the measurement technology
- ▶ Consistent quality of the position measurement over the service life



Energy / media consumption
No sealing air necessary for protection class IP67



Maintenance & service
Measuring function maintenance-free due to non-contact measuring principles

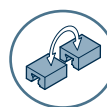

Simple service
Proven Rexroth exchange construction

Applications in automation

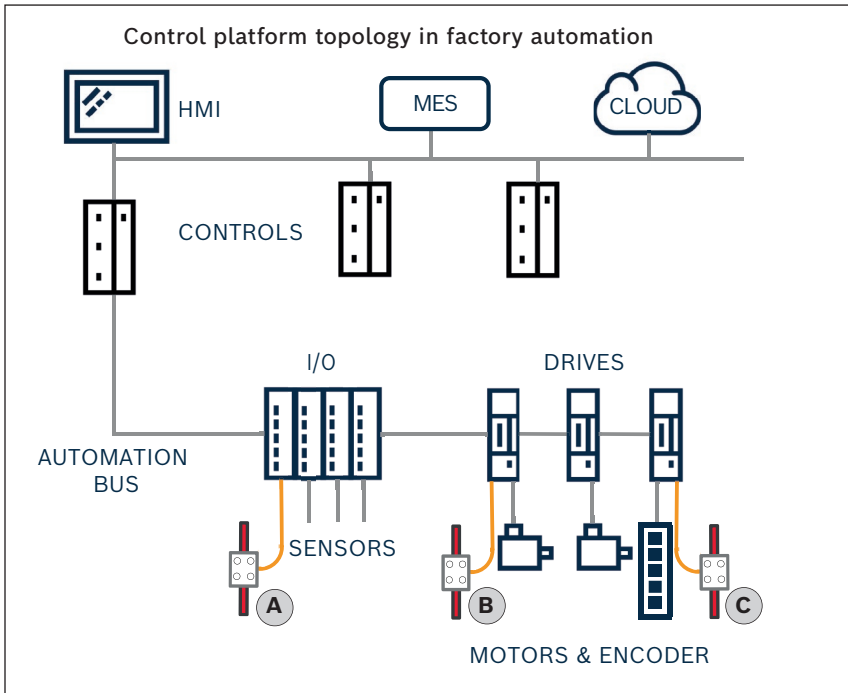

Applications for IMScompact in automation:

IMScompact is used in the field of industrial automation mostly in sensor-level applications at I/O modules or drives.

- A** Position sensor at I/O modules or digital indicators
- B** Closed control circuit: Increase in positioning accuracy at linear axes
- C** Drive systems with linear motors

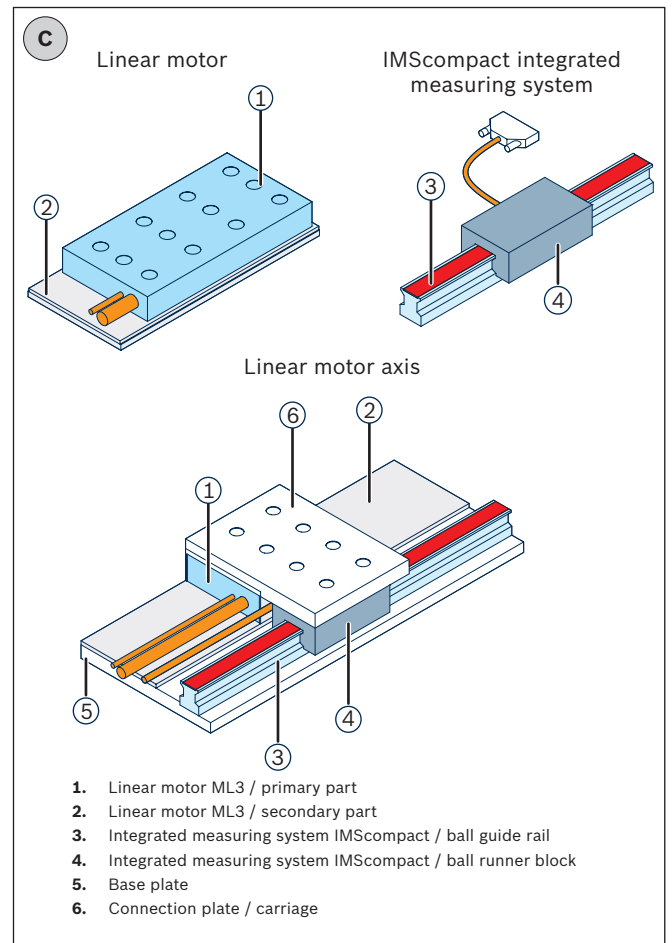
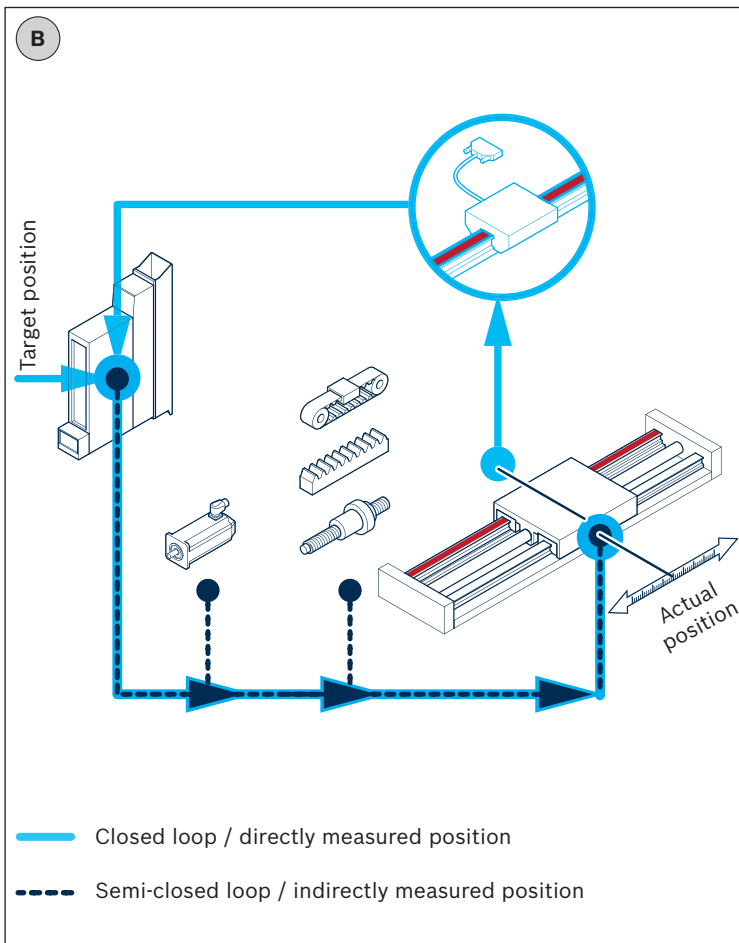

Technical data

Dimensioning and calculations

The IMScompact measuring system runner block is based on the proven ball runner block BSHP in CS design.

The dimensioning and calculation including the nominal life expectancy calculation is implemented analogously to the calculation for the profiled rail system without measuring system according to the catalog information in the catalog "Ball rail systems BSHP".

The external loads acting on the system are distributed among the runner blocks depending on the arrangement. The loads caused by forces and torques resulting from the effective forces need to be calculated for each runner block when performing the life expectancy calculation. For the IMScompact runner blocks, whichever arrangement is selected, the relevant values for F_{\max} and M_{\max} must be complied with in the application. The respective values can be obtained from the corresponding dimension tables.

In addition, admissible screw forces and maximum transferable lateral forces must be observed in compliance with the catalog information of „BSHP ball guide rails“.

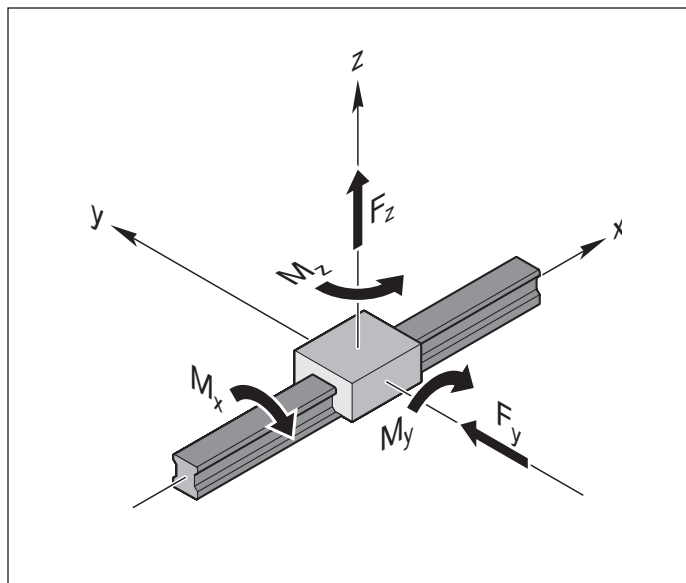

[IMScompact instructions](#)

IMScompact runner block

Structural design

In an internal pouch of the runner block, the measuring sensor is assembled as compact unit with plastic enclosure. It comprises the incremental and reference sensor as well as the signal processing and the cable outlet. The cable is guided through a bore hole located opposite the side with the reference edge to the outside and mechanically strain-relieved at the runner block. The measuring sensor is already fully adjusted to the ideal measuring distance. The other characteristics of the runner block correspond to the ball rail system BSHP. Due to the sensors integrated into the steel body, an excellent EMC protection is achieved. The steel runner block also covers the magnetic scale. This structure enables effective shielding from external magnetic fields (e.g. secondary parts of linear motors) without any impact on the measuring system.

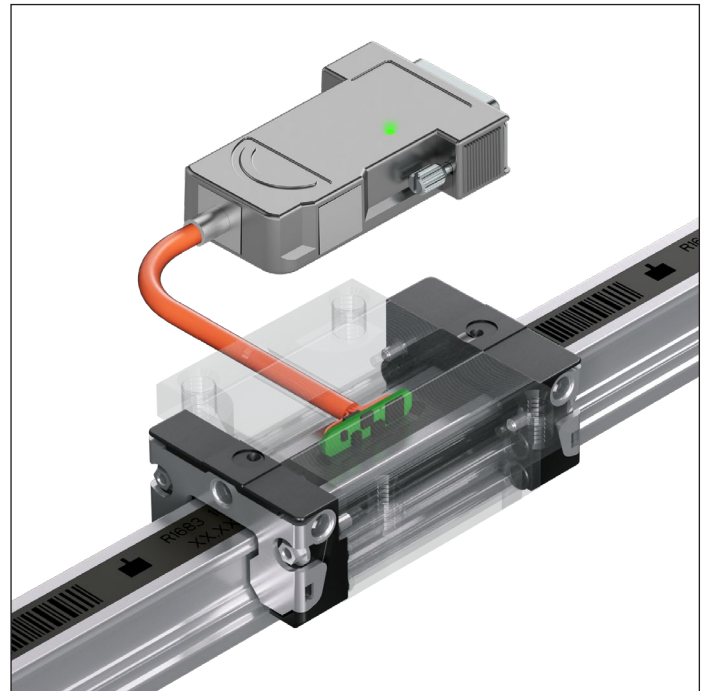

The structure of runner blocks with absolute interface is identical to incremental systems and they use identical rails and scales. The electronics for the absolute interface are integrated in the connector. If the voltage supply is deactivated, the measuring system is supplied by a lithium-ion battery to ensure the absolute measuring function. The operating mode is indicated by an integrated status LED (1).

After one-time commissioning by a reference run over three reference marks, the absolute position value of the scale is returned and will from now on be available directly after activation. Alternatively, the absolute zero point can also be set manually in any installation position using a reset button (2).

Thanks to the rechargeable lithium-ion battery, the absolute position value is available directly after activation. The buffer time of the battery is six months even if the measuring system is moved temporary during buffer operation.

For detailed description of the operating modes see:

[IMScompact instructions](#)

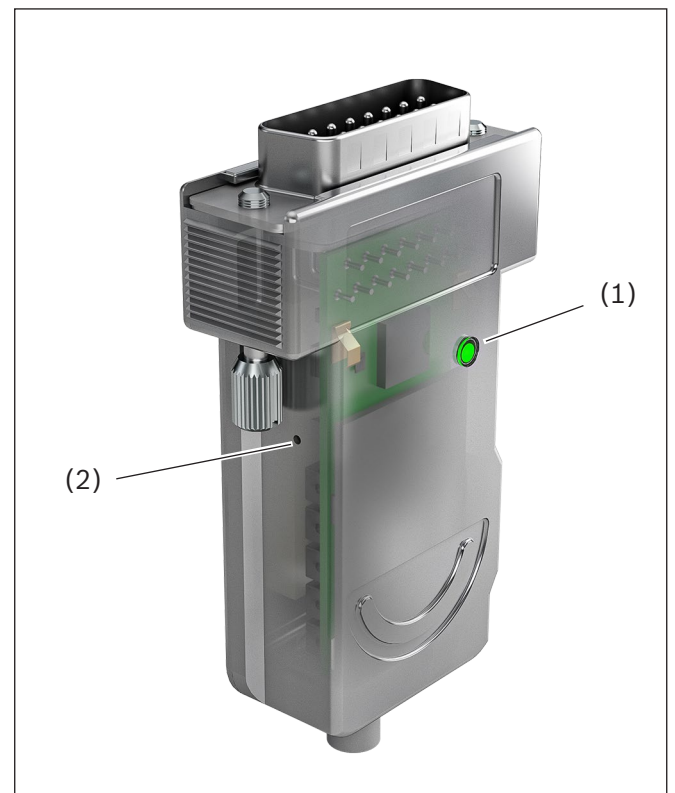

The battery used is checked according to UN 38.3 and registered.

The battery is a single-cell lithium-ion battery (integrated into the device). The nominal capacity of the lithium-ion battery does not exceed the relevant energy content limit of 100Wh for transports.

Installation direction of the magnetic strip relative to the IMCompact runner block.

The installation direction of the magnetic strip must correspond to the installation direction of the IMCompact runner block. On the magnetic strip, there is a pictogram (1) showing an IMCompact runner block with cable outlet. It must be ensured that the cable outlet of the IMCompact runner block is on the same side as shown on the pictogram (1) of the magnetic strip.

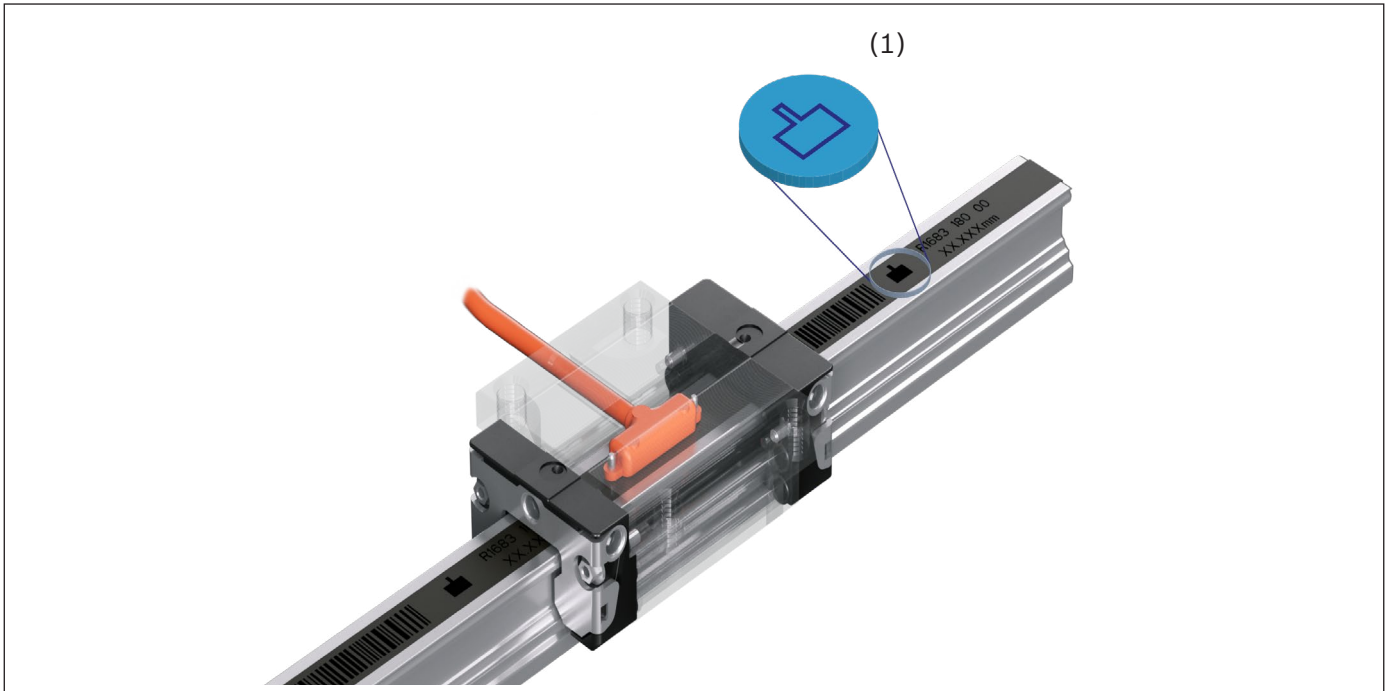

Definition of the motion direction

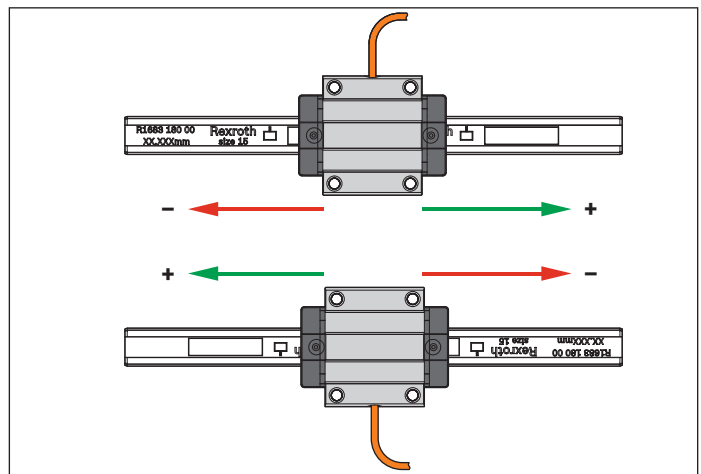

Sealing

- ▶ As is the case with all BSHP runner blocks, the interior of the runner block and the measuring sensor are protected by two end seals (1) and four longitudinal seals (2). The end seals can be replaced when worn.
- ▶ For rough ambient conditions such as chips, dusts and fluids, additional front seals and wipers from the BSHP range of accessory products are available.

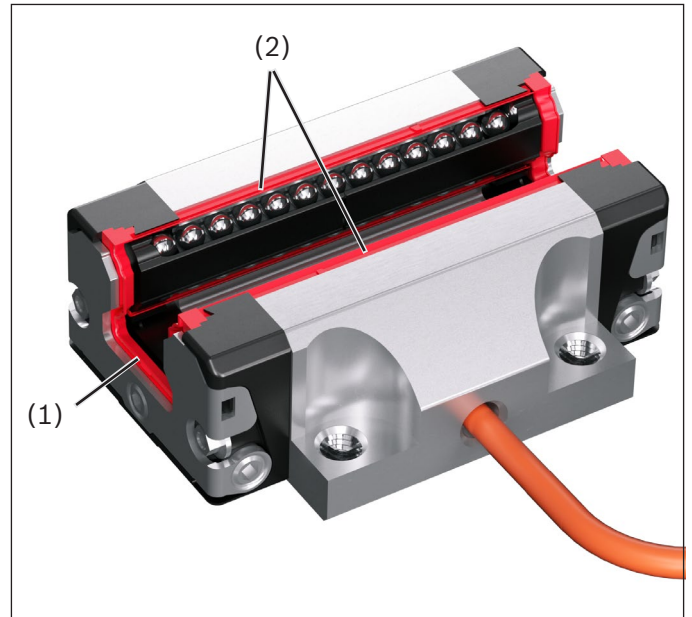

- ▶ The magnetic strip consists of a tribologically optimized mix of materials and offers a good running surface for the seals in a common industrial environment. Ferromagnetic substances in the sensor air gap may interfere with the measuring signal and must be kept outside by means of corresponding wipers (cover plate wipers, front seals). Cover plate wipers and front seals in combination with the optional cover strip offer the best protection (see accessories).

Operating conditions:

General for incremental and absolute systems

Travel speed v_{\max}	5 m/s
Reference speed v_{Ref}	0.5 m/s
Acceleration a_{\max}	500 m/s ²
	30 m/s ² (in battery mode only with IMScompact absolute)
Shock (EN 60068-2-27)	500 m/s ² / 11 ms
Vibration (EN 60068-2-6)	100 m/s ² (57 Hz - 2000 Hz)
Operating temperature*	0 ... 80 °C
Storage/transport temperature*	-10 ... 80 °C
Relative air humidity during storage	max. 95%
Relative air humidity in operation	max. 80% at 20°C
Protection class of scanner (EN 60529)	IP67
Protection class of DSUB connector (EN 60529)	IP40
EMC	EN 61326-1
	EN 61000-6-3 / EN 61000-6-4
RoHS compliant	yes
UL compliant	Cable UL AWM STYLE 20549
	Casting compound UL 94VO

* For details see: [IMScompact instructions](#)

Functional safety - Safe Motion

The suitability of the IMSccompact for functional safety in the overall system (electrical signal path and mechanical integration) is currently in preparation. For this reason, the mechanical connection of IMSccompact is to be evaluated by the corresponding designer and/or machinery engineer taking into consideration the safety-related aspects, and the results are to be used in the hazard analysis. For applications with functional safety, the magnetic strip must be glued-in at all times. Corresponding IMSccompact versions are currently prepared.

Electrical interface, incremental: analog sinusoidal signals 1 V_{ss} (option I9)

The 1 V_{ss} analog interface (option I9) is predestined for the highly dynamic position control of linear motors, belt drives or screw drives. The sinusoidal incremental signals A and B are phase-offset by 90° to each other and have a typical signal amplitude of 1 V_{ss}.

- A, B and RI fully differential, for motion in the positive counting direction.

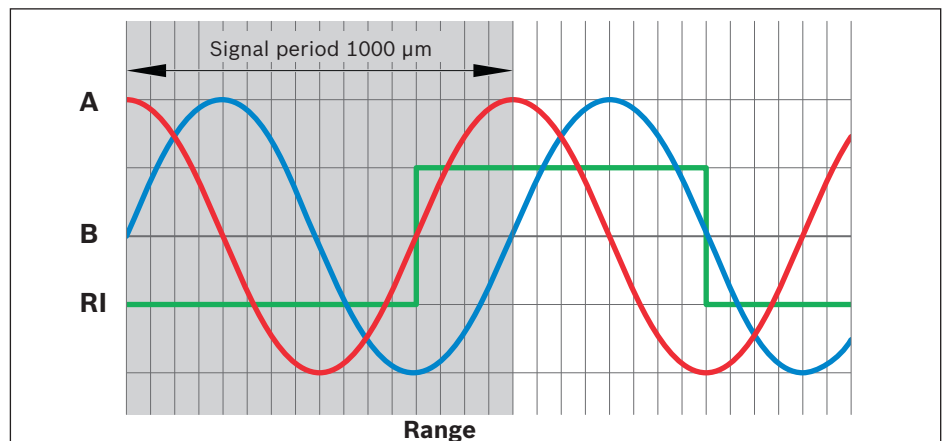

Option	Signal period (μm)	Max. scanner speed (m/s)	Max. reference run speed (m/s)
I9	1000	5.0	≤ 0.5

The illustrated output signal sequence (**B** phase-lagged to **A**) applies to scanner motions in the positive counting direction. The differential reference mark signal **RI** has an amplitude of approx. -0.7 V when inactive (low). In the active state (high), the amplitude amounts to $+0.7$ V. The indicated amplitude values apply to an operation with terminating resistor $Z_0 = 120 \Omega$.

- ▶ $Z_0 = 120.00 \Omega$
 $U_{com} = 2.5 \text{ V}$

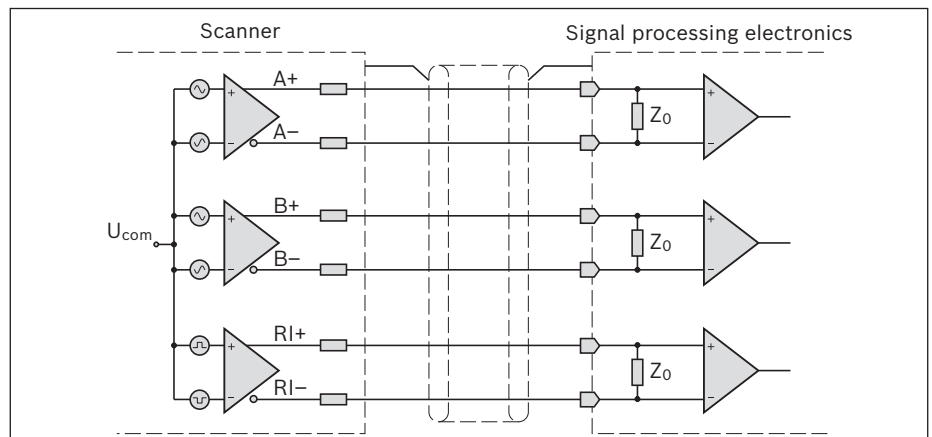

Electrical interface, incremental: digital square-wave output signal TTL, 10 μm resolution (option I4)

The digital TTL interface (option I4) is used for the position display or the position transmission to programmable logic controllers or measuring value displays. The digital incremental signals A and B comply with the EIA/TIA-422-A standard. They are phase-offset by 90° and have the following signal levels: $U_{high} > 2 \text{ V}$; $U_{low} < -2 \text{ V}$.

The differential reference mark signal RI has the same electrical characteristics as the incremental signals.

The amplitudes apply to the operation with a terminating resistor $Z_0 = 120 \Omega$.

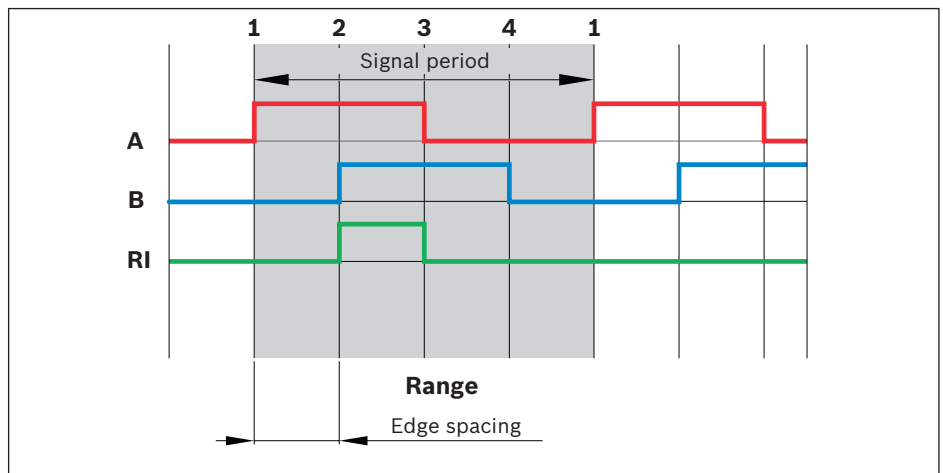

Option	Resolution (edge spacing) (μm)	Signal period (μm)	Max. scanner speed (m/s)	Max. reference run speed (m/s)
I4	10	40	5.0	≤ 0.5
Voltage supply		10 ... 30VDC		
Current consumption		1 Vss at 12 V: 19.5 mA 1 Vss at 24 V: 11.3 mA TTL at 12 V: 51.0 mA TTL at 24 V: 28.5 mA		

Electrical interface, absolute: SSI – Synchronous Serial Interface (options: S1) combined with analog 1 Vss

With the synchronous serial interface (SSI), the absolute position information is transferred to higher-level evaluation electronics via serial data transmission. Parallel to the serial data transmission, the incremental sinusoidal and cosine signals (analog option I9) are also available for enhancing the control performance.

Option	S1
Coding	Binary
Number of bits Position/Databits	22
Number of special bits	3
- Parity	Straight
- Error bit	Yes
- Warning bit	Yes
Total number of bits	25
Resolution of the digital interface	10 µm
Max. clock frequency	500 kHz
Voltage supply	10 ... 30 V
Current consumption	max. 100 mA

Absolute system interface with connector electronics and Li-ion battery

Nominal buffer time	6 months
Energy content of lithium-ion battery	0.9 Wh
Storage temperature range	-10 ... 60 °C
Operating temperature range	0...40 °C

Requirements for the power supply of the IMSccompact measuring systems (from the point of view of EMC):

The measuring systems are designed to be operated directly via a point-to-point connection with the evaluating unit, for example a drive controller. In this case, the evaluating unit takes over the DC voltage supply in the defined range (see chapter „Technical data“) of the measuring system. The connection is considered as signal interface. The evaluating unit, the product, must comply with the relevant harmonized standards (generic or product standards) in accordance with the currently valid EMC Directive as specified in the Declaration of Conformity.

As an example of the evaluating unit for Bosch Rexroth drive systems, EN 61800-3: Variable speed electrical drive systems applies. To other products, EN 61000-6-2: Electromagnetic compatibility (EMC) – Part 6-2: Generic standards – Immunity standard for industrial environments may apply. Related detailed information can be found in the operating instructions of the evaluating unit.

If you use the measuring system in a way that deviates from the installation instructions given here (point-to-point connection) or if you do not have any information about the evaluating unit used, e.g. the drive system used, or if the EMC environment at the place of use is difficult or hard to evaluate, it is for IMSccompact absolute systems necessary to use an additional filter plug to comply with the requirement of the currently valid EMC directive according to the declaration of conformity. This plug is available under R168393010 (see chapter “Accessories”).

Cables and connectors

Cables

The length of the connection cable at the IMScompact runner block can be selected in steps of 0.5 m up to a maximum length of 3.0 m. The cable outlet at the runner block can be implemented flexibly in all directions.

Due to the high supply voltage in connection with the analog, differential signal transmission, in practice, cable lengths of up to a maximum of 75 meters can be realized without any restrictions. With the digital absolute interface (SSI), the indicated maximum cable lengths are to be taken into consideration depending on the frequency. This cable type can be ordered as extension cable (see accessories).

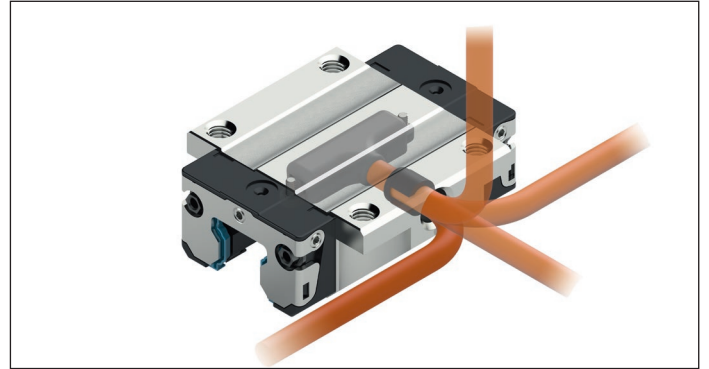

Specification

- ▶ Lif9YC11Y 5x2x0.09 mm² (AWG28), suitable for drag chains
- ▶ Minimum length 0.2 m
- ▶ Outer diameter $d=5.0^{+0.2}$ mm
- ▶ Wires stranded in pairs, pairs stranded
- ▶ Wire insulation PP
- ▶ Wire colors DIN47100
- ▶ Shield: Tin-coated CU mesh with non-woven banding and polyester foil
- ▶ Sheath: PUR color: orange RAL2003
- ▶ UL 20549/10954
- ▶ Recommended bending radius for one-time bending (stationary): 5 x d (outer diameter)
- ▶ Recommended bending radius for alternating bends (drag chain): 10 x d
- ▶ 2 mil. bending cycles at a bending radius of 75 mm (tested at $a=3 \text{ m/s}^2$ and $v=2.5 \text{ m/s}$)

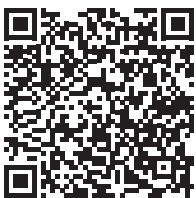
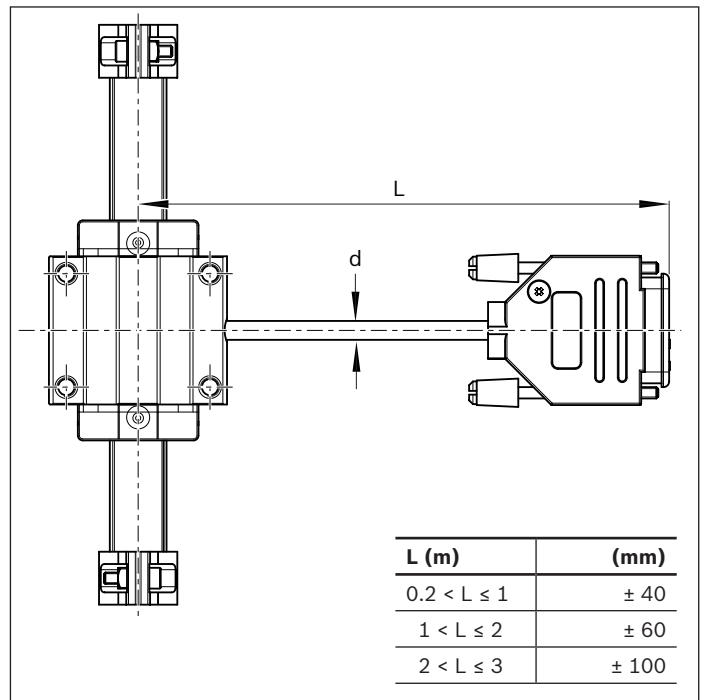

[IMScompact instructions](#)

Connectors and assignment

Type E and F:

DSUB 15-pin male, protection class IP40

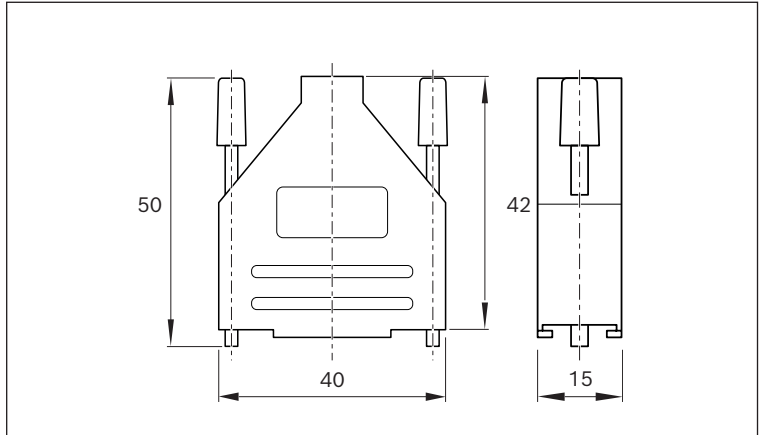

Option I9

Type E: Signal, incremental 1Vss

Pin	Cable color	Signal, incremental 1Vss
1		
2	Green	A+
3	Yellow	A-
4	Blue	0V
5	Brown	B+
6	White	B-
7		
8		
9	Pink	R+
10	Gray	R-
11	Red	10 ... 30VDC
12		
13		
14		
15		
Housing	Shield	GND

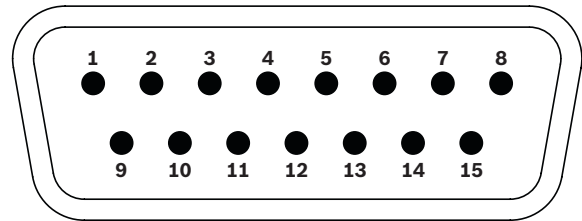

D-Sub 15 Pin male

Option I4

Type F: Signal, incremental TTL

Pin	Cable color	Signal, incremental TTL
1		
2		
3		
4	Blue	0V
5		
6		
7	Green	A+TTL
8	Yellow	A-TTL
9	Pink	R+TTL
10	Gray	R-TTL
11	Red	10 ... 30VDC
12		
13	Brown	B+TTL
14	White	B-TTL
15		
Housing	Shield	GND

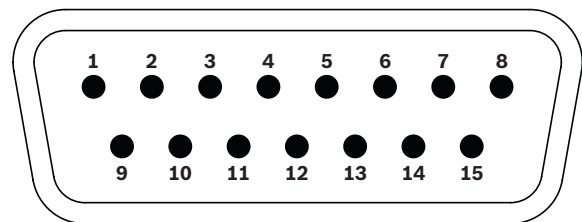

D-Sub 15 Pin male

Type G: Absolute SSI signal

DSUB 15-pin male with integrated electronics, protection class IP40

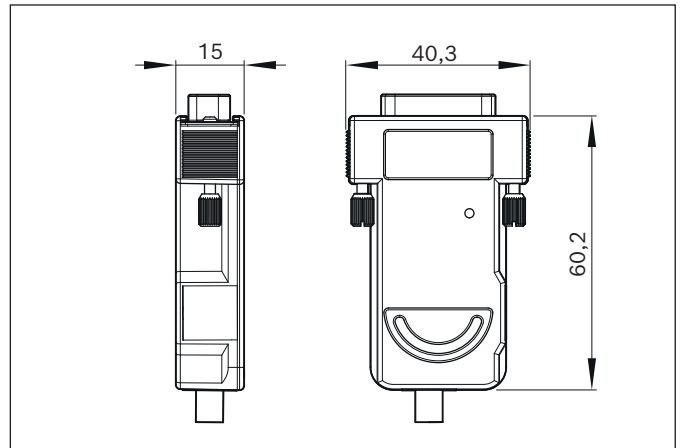

Pin	Cable color	Absolute SSI signal
1		
2	Green	A+
3	Yellow	A-
4	Blue	0V
5	Brown	B+
6	White	B-
7	Black	EncData+
8	Purple	EncData-
9		
10		
11	Red	10 ... 30VDC
12		
13	Pink	EncCLK+
14	Gray	EncCLK-
15		
Housing	Shield	GND

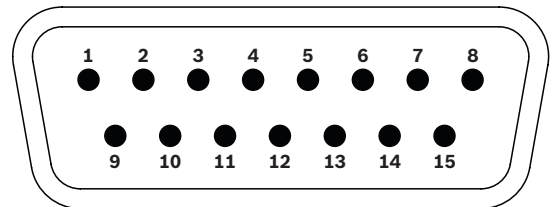

D-Sub 15 Pin male

Type 0: Open cable end (only for options I9 and I4, incremental measuring system)

- ▶ Stripping length 20 mm
- ▶ Insulation stripping length 5 mm
- ▶ Drilled strands

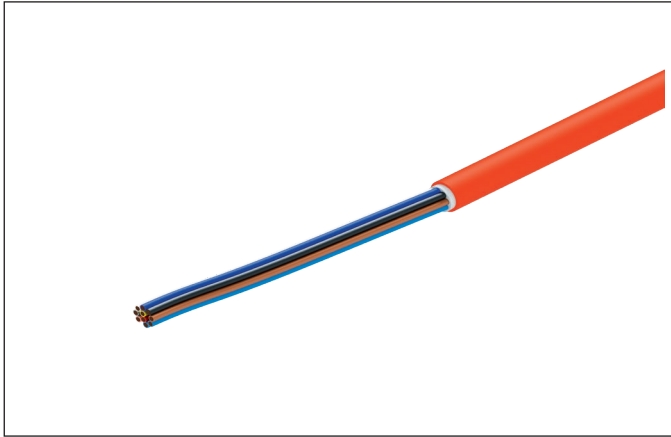

Cable color	1Vss (option I9)	TTL (option I4)
Green	A+	A+ TTL
Yellow	A-	A- TTL
Blue	0V	0V
Brown	B+	B+ TTL
White	B-	B- TTL
Red	10 ... 30VDC	10 ... 30VDC
Pink	R+	R+ TTL
Gray	R-	R- TTL
Shield	GND	GND

Magnetic strip

Structural design and specification

The magnetic strip consists of three firmly glued components:

- 1** Two-track magnetic strip made of plastic which holds the position information, 1 mm pole width, distance-coded
- 2** Stainless steel flexible conductive strip
- 3** Transfer adhesive tape with protective wrapping

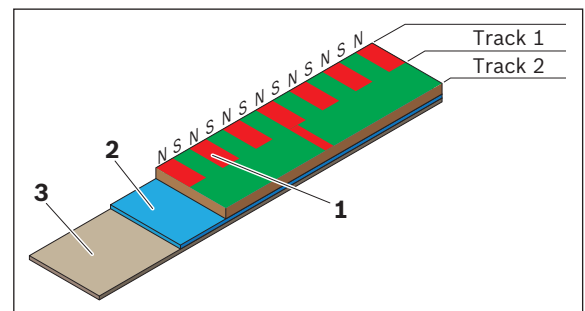

The magnetic strip has two tracks, with an incremental and a reference side. The incremental track comprises 1 mm increments. On the reference side, distance-coded reference marks are provided. The clear arrangement of the reference marks ensures that an absolute position is already available when two marks have been passed. This enables measuring lengths of up to 17.8 m. The necessary minimum length ¹⁾ of the magnetic strip for evaluating the distance-coded reference marks is 400 mm. If the length of the magnetic strip is shorter than 400 mm, the measuring system may only be used as incremental measuring system without evaluation of reference marks. When using IMScompact absolute (option S1), the absolute zero point can also be set manually in any installation position.

For details see: [IMScompact instructions](#)

1) The minimum length may also be shorter depending on the mechanical version.

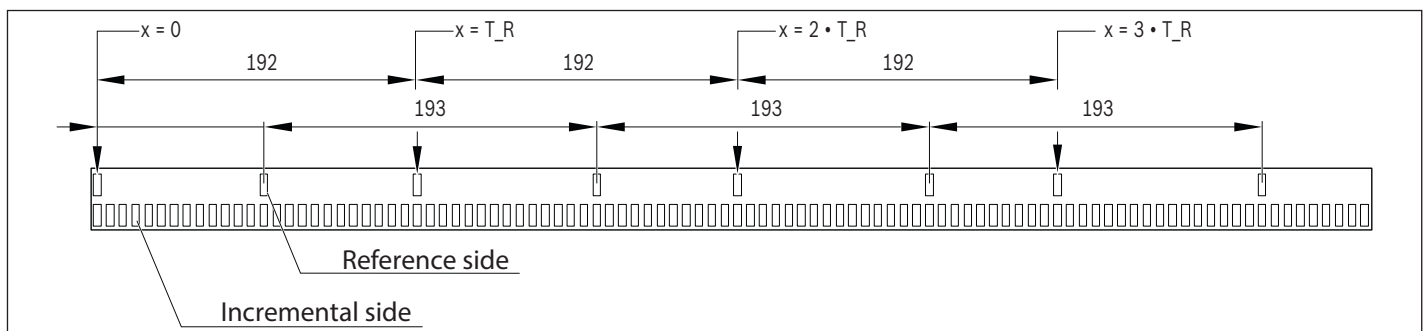

The following specifications apply:

Material	CPE with 90% strontium ferrite (magnet carrier)
Coding	incremental, two-track system (reference track)
Pole pitch	1 mm
Reference track	Distance-coded, $T_R = 192$ mm
Minimum length for the evaluation of the distance coding	400 mm
Operating temperature, processed	0 ... +80°C
Optimum storage temperature, unprocessed	+18 °C
Adhesion temperature	+18 ... +30 °C
Humidity	Max. 95%, non-condensing
Accuracy	± 20 $\mu\text{m}/\text{m}$
Carrier strip material	Precision steel strip, 1.4310
Adhesive tape	3M-9088
Dimensions	Width: 8 / 10 / 12 mm ± 0.1 mm
Longitudinal expansion coefficient	$\alpha = 16 \times 10^{-6}$ 1/K
Thermal longitudinal expansion	In the glued-on condition, the longitudinal expansion of the magnetic strip corresponds to the one of the rail. With a massive mounting base, the latter is in turn determined by the longitudinal expansion of the substructure.
Weight	Approx. 60 g/m
Impact of external magnets	External magnetic fields at the surface of the magnetic strip max. 64 mT (640 Oe; 52 kA/m) to prevent damage.
Bending radius	Min. 150 mm

Handling

To avoid tensions in the magnetic strip, it must not be stretched, twisted or stored/handled with the magnetized plastic strip directed to the inside. If the magnetic strip is reeled up, a partition layer must be used to avoid any damage. If the magnetic strip is reeled up, inserting a partition layer for avoiding damage is recommended. When being stored in a non-glued condition, the recommended storage temperature is to be complied with to avoid a weakening of the transfer adhesive layer.

Mounting

The system is mounted by adhesion of the rail slot. Before mounting, the correct mounting orientation is to be ensured since, with the mounted magnetic strip, the push-on direction and thus the position of the reference edge of the runner block are determined. A magnetic strip which has already been glued on is destroyed after its removal and cannot be re-used. Before the adhesion of the magnetic strip, the latter is to be stored near the rail (ideally in the slot) for approx. 30 minutes so that the temperature corresponds to the rail temperature and any tensions due to thermal expansion can be excluded. After mounting, the strip ends are to be secured with strip clamps.

Mounting steps:

- 1 Thoroughly clean the surface
- 2 Acclimatize the magnetic strip
- 3 Remove the protective wrapping and attach the magnetic strip with a great pressure force (4-5 kg/cm²)
- 4 Cover it with lubricant (if no cover strip is used), push-on the runner block, secure it with strip clamps

The following preparation instructions are to be observed:

Preparing the surface

To guarantee an ideal adhesion, any anti-adhesive contamination in the rail slot (e.g. oil, grease, dust, separating agents) must be removed with solvents with residue-free evaporation. Suitable agents are ketones or alcohols. When using solvents, the manufacturer's instructions are to be observed at all times!

Pressure force

The rigidity of the adhesion directly depends on the contact developed by the adhesive with the surfaces to be glued. The ideal pressure force is 4 to 5 kg/cm² (use press-on aids if applicable).

Adhesion temperature

The most favorable adhesion temperature is between +18°C and +30°C. Adhesions in which the surfaces to be glued are colder than +10°C are to be avoided since, in such case, the adhesive becomes too hard and, therefore, a sufficient instant adhesion cannot be achieved. After proper adhesion, the rigidity of the connection is also guaranteed with temperatures in the minus range. According to our experience, the final adhesion force of an adhesion is reached after approx. 72 hours (at +21°C). For adhesion, only the transfer adhesive tape which is included in the scope of delivery and already attached to the magnetic strip is to be used.



[IMScompact instructions](#)



[Assembly video](#)

IMScompact guide rail

The IMScompact guide rail corresponds to a modified standard rail with slot which is secured with screws from above. Due to the magnetic strip, the use of plastic mounting hole plugs for protection against contamination and of seals can be omitted.

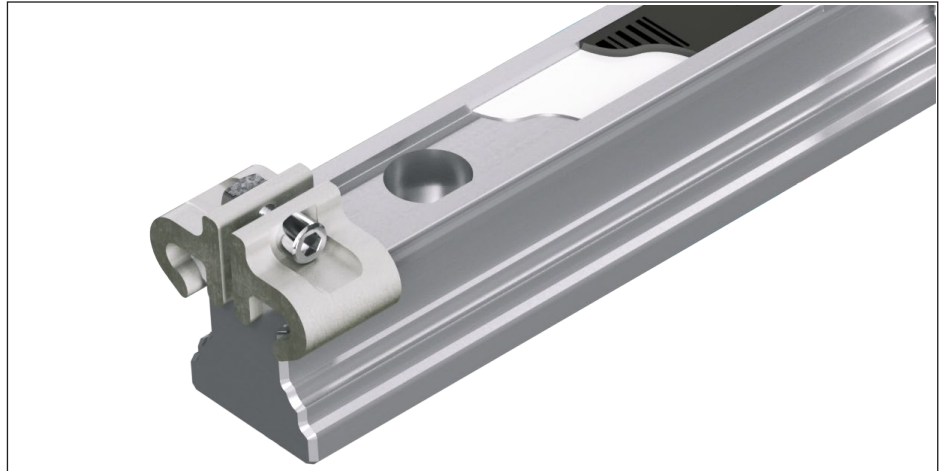

The longitudinal expansion coefficient of the rail is $\alpha_{\text{therm}} = 11 \cdot 10^{-6} \text{ K}^{-1}$. Generally, the thermal expansion coefficient of the overall system secured with screws with the magnetic strip being affixed corresponds to the one of the mounting base, provided that it is sufficiently rigid towards the rail.

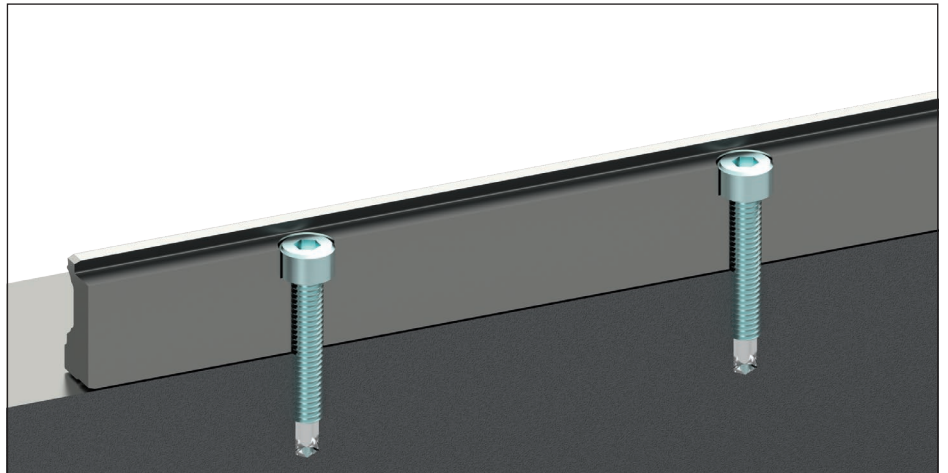

Accuracy

Repeatability

The repeatability is the maximum position deviation that can occur with the repeated run-up of the same position. It is smaller than $\pm 1 \mu\text{m}$ at any measuring point.





System accuracy

The system accuracy of the measuring system, consisting of scanner and magnetic strip, corresponds to $\pm 20 \mu\text{m/m}$. This is the maximum linearity deviation for any measured travel of maximally 1 m across the length of the magnetic strip.

Ball runner block for IMScompact

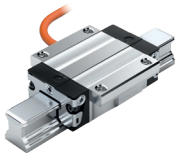
Product overview and type key

Ball runner blocks are delivered with standard seals (SS) or low-friction seals (LS) in an initially pre-lubricated/preserved version without ball chain. Generally, they comply with accuracy class P in the preload classes C1 and C2. The following versions are available. Special versions are possible upon request.

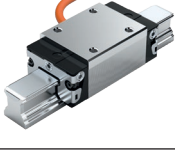
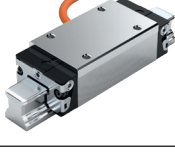
Format	Size 15		Size 20		Size 25	
	C1	C2	C1	C2	C1	C2
 FNS (R1651)	✓	✓	✓	✓	✓	✓
 FLS (R1653)	✓	✓	✓	✓	✓	✓
 SNS (R1622)	✓	✓	✓	✓	✓	✓
 SLS (R1623)	✓	✓	✓	✓	✓	✓
 SNH (R1621)	✓	✓			✓	✓
 SLH (R1624)					✓	✓

Short type designation / ordering code for IMScompact ball runner block:

I	M	S	C	-	K	W	D	-	0	2	0	-	F	N	S	-	C	1	-	P	-	S	S	-	0	-	0	1	-	I	9	-	E	-	3	0	0	-	D	
									1				2				3		4				5		6			7			8			9			10			11

1 Size

Characteristic	Name
015	Size 15
020	Size 20
025	Size 25

2 Format

Characteristic	Name
FNS	Flanged, normal, standard height
FLS	Flanged, long, standard height
SNS	Slimline, normal, standard height
SLS	Slimline, long, standard height
SNH	Slimline, normal, high
SLH	Slimline, long, high

3 Preload class

Characteristic	Name
C1	Preload 2% C
C2	Preload 8% C

4 Accuracy class

Characteristic	Name
P	Precision

5 Seal

Characteristic	Name
SS	Standard
LS	Low-friction

6 Ball chain

Characteristic	Name
0	Without ball chain

7 Lubrication

Characteristic	Name
01	With initial lubrication, preserved
02	Preserved

8 Interface

Characteristic	Name
I9	1Vss / 1000 µm
I4	TTL 10 µm
S1	SSI 10 µm

9 Connector type

Characteristic	Name
F	15-pin sub-D. pins, TTL/EC
E	15-pin sub-D. pins, 1Vss/EC
0	Open cable end
G	15-pin sub-D pins SSI/EC

10 Cable length

Characteristic	Name
300	3.00 m
250	2.50 m
200	2.00 m
150	1.50 m
100	1.00 m
050	0.50 m
020	0.20 m

11 Documentation

Characteristic	Name
D	Standard

In the type key, it is impossible to combine different signal types with characteristics 8 and 9.
E.g.: The combination of interface I9 (1Vss) with connector type F (TTL) is impossible.

FNS (Flanged, normal, standard height)

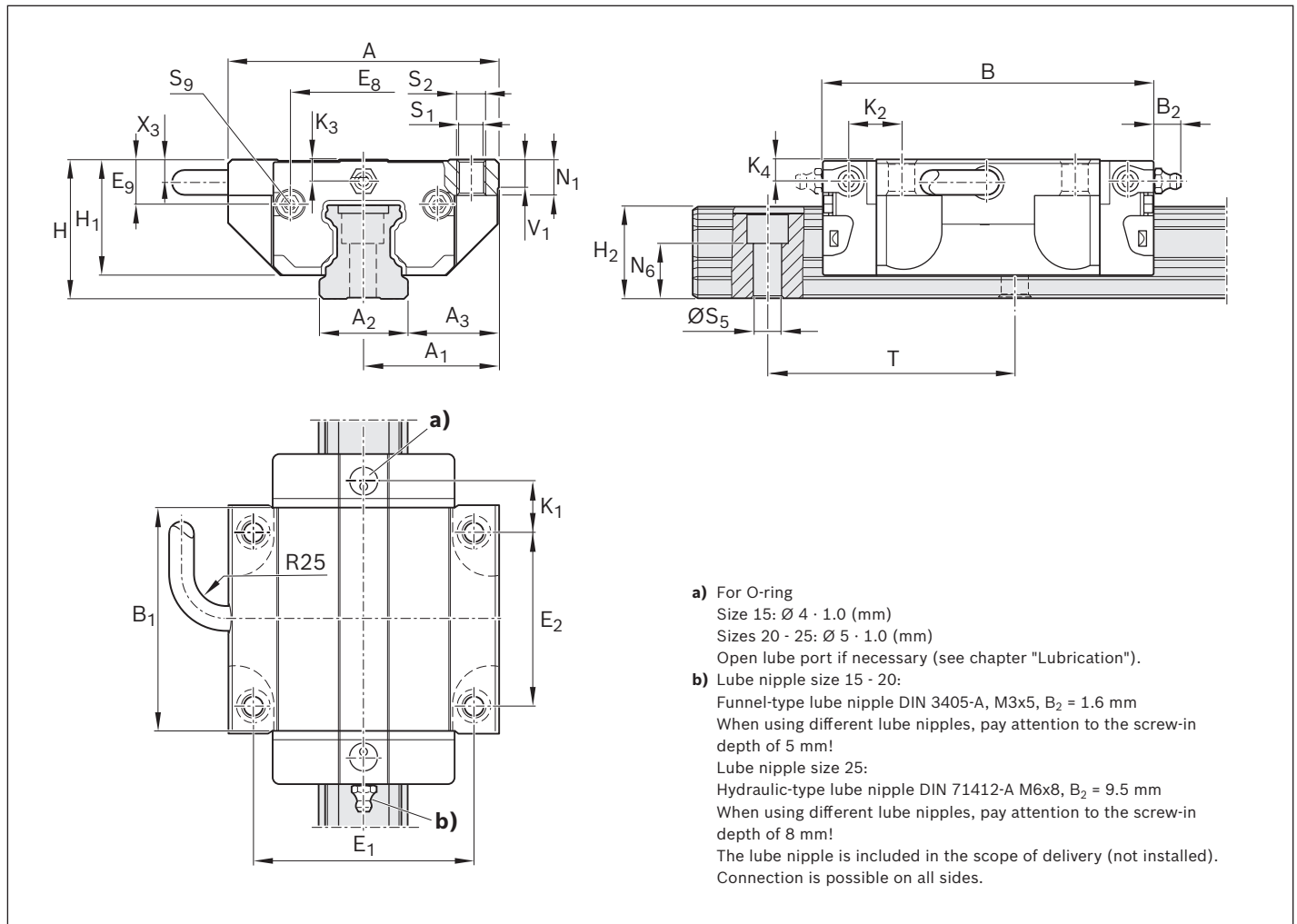

Size	Dimensions (mm)																			
	A	A ₁	A ₂	A ₃	B ^{+0,5}	B ₁	E ₁	E ₂	E ₃	X ₃	E ₈	E ₉	H	H ₁	H ₂ ¹⁾	H ₂ ²⁾	K ₁	K ₂	K ₃	K ₄
15	47	23.5	15	16.0	58.2	39.2	38	30	26	4.25	24.55	6.70	24	19.90	16.30	16.20	8.00	9.6	3.20	3.20
20	63	31.5	20	21.5	75.0	49.6	53	40	35	5.90	32.50	7.30	30	25.35	20.75	20.55	11.80	11.8	3.35	3.35
25	70	35.0	23	23.5	86.2	57.8	57	45	40	8.25	38.30	11.50	36	29.90	24.45	24.25	12.45	13.6	5.50	5.50

Size	Dimensions (mm)										Mass (kg)	Load ratings (N)		Load moments (Nm)			
	N ₁	N ₂	N ₆ ^{±0,5}	S ₁	S ₂	S ₅	S ₉	T	V ₁	m		C	F _{max}	M _t	M _{t_max}	M _L	M _{L_max}
15	5.2	4.40	10.3	4.3	M5	4.5	M2,5x3,5	60	5.0	0.20	9 860	3 290	95	30	68	20	
20	7.7	5.20	13.2	5.3	M6	6.0	M3x5	60	6.0	0.45	23 400	7 800	300	100	200	70	
25	9.3	7.00	15.2	6.7	M8	7.0	M3x5	60	7.5	0.65	28 600	9 530	410	140	290	100	

1) Dimension H₂ with cover strip
 2) Dimension H₂ without cover strip

FLS (Flanged, long, standard height)

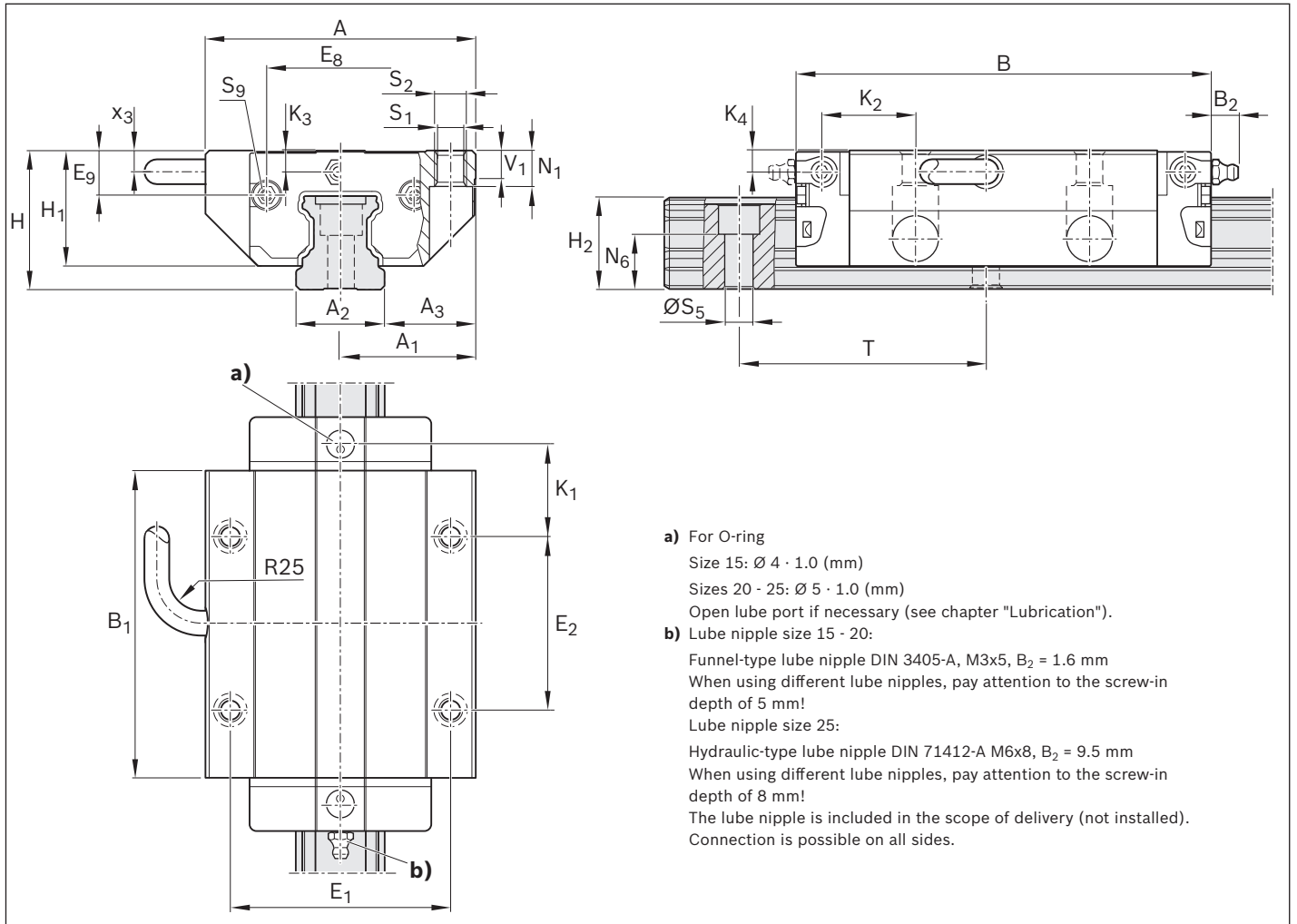

Size	Dimensions (mm)																			
	A	A ₁	A ₂	A ₃	B ^{+0,5}	B ₁	E ₁	E ₂	X ₃	E ₈	E ₉	H	H ₁	H ₂ ¹⁾	H ₂ ²⁾	K ₁	K ₂	K ₃	K ₄	
15	47	23.5	15	16.0	72.6	53.6	38	30	4.25	24.55	6.70	24	19.90	16.30	16.20	15.20	16.80	3.20	3.20	
20	63	31.5	20	21.5	91.0	65.6	53	40	5.90	32.50	7.30	30	25.35	20.75	20.55	19.80	19.80	3.35	3.35	
25	70	35.0	23	23.5	107.9	79.5	57	45	8.25	38.30	11.50	36	29.90	24.45	24.25	23.30	24.45	5.50	5.50	

Size	Dimensions (mm)										Mass (kg)	Load ratings (N)		Load moments (Nm)			
	N ₁	N ₂	N ₆ ^{±0,5}	S ₁	S ₂	S ₅	S ₉	T	V ₁	m		C	F _{max}	M _t	M _{t,max}	M _L	M _{L,max}
15	5.2	4.40	10.3	4.3	M5	4.5	M2,5x3,5	60	5.0	0.30	12 800	4 270	120	40	120	40	
20	7.7	5.20	13.2	5.3	M6	6.0	M3x5	60	6.0	0.55	29 600	9 870	380	130	340	110	
25	9.3	7.00	15.2	6.7	M8	7.0	M3x5	60	7.5	0.90	37 300	12 430	530	180	530	180	

- 1) Dimension H₂ with cover strip
 2) Dimension H₂ without cover strip

SNS (Slimline, normal, standard height)

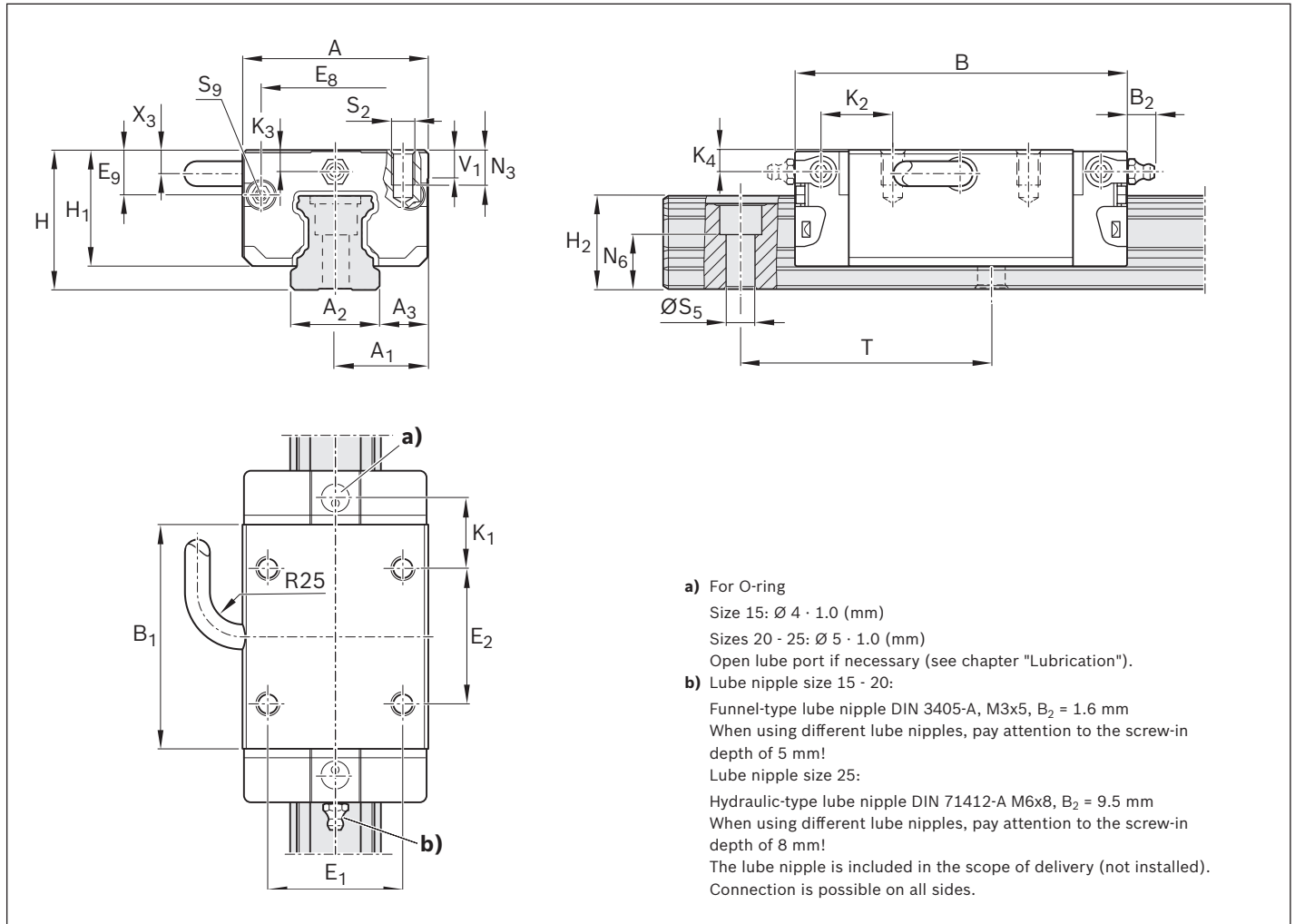

Size	Dimensions (mm)																			
	A	A ₁	A ₂	A ₃	B ^{+0,5}	B ₁	E ₁	E ₂	X ₃	E ₈	E ₉	H	H ₁	H ₂ ¹⁾	H ₂ ²⁾	K ₁	K ₂	K ₃	K ₄	
15	34	17	15	9.5	58.2	39.2	26	26	4.25	24.55	6.70	24	19.90	16.30	16.20	10.00	11.60	3.20	3.20	
20	44	22	20	12.0	75.0	49.6	32	36	5.90	32.50	7.30	30	25.35	20.75	20.55	13.80	13.80	3.35	3.35	
25	48	24	23	12.5	86.2	57.8	35	35	8.25	38.30	11.50	36	29.90	24.45	24.25	17.45	18.60	5.50	5.50	

Size	Dimensions (mm)									Mass (kg)	Load ratings (N)		Load moments (Nm)			
	N ₃	N ₆ ^{±0,5}	S ₂	S ₅	S ₉	T	V ₁	m	C		F _{max}	M _t	M _{t,max}	M _L	M _{L,max}	
15	6.0	10.3	M4	4.5	M2,5x3,5	60	5.0	0.15	9 860	3 290	95	30	68	20		
20	7.5	13.2	M5	6.0	M3x5	60	6.0	0.35	23 400	7 800	300	100	200	70		
25	9.0	15.2	M6	7.0	M3x5	60	7.5	0.50	28 600	9 530	410	140	290	100		

1) Dimension H₂ with cover strip
 2) Dimension H₂ without cover strip

SLS (Slimline, long, standard height)

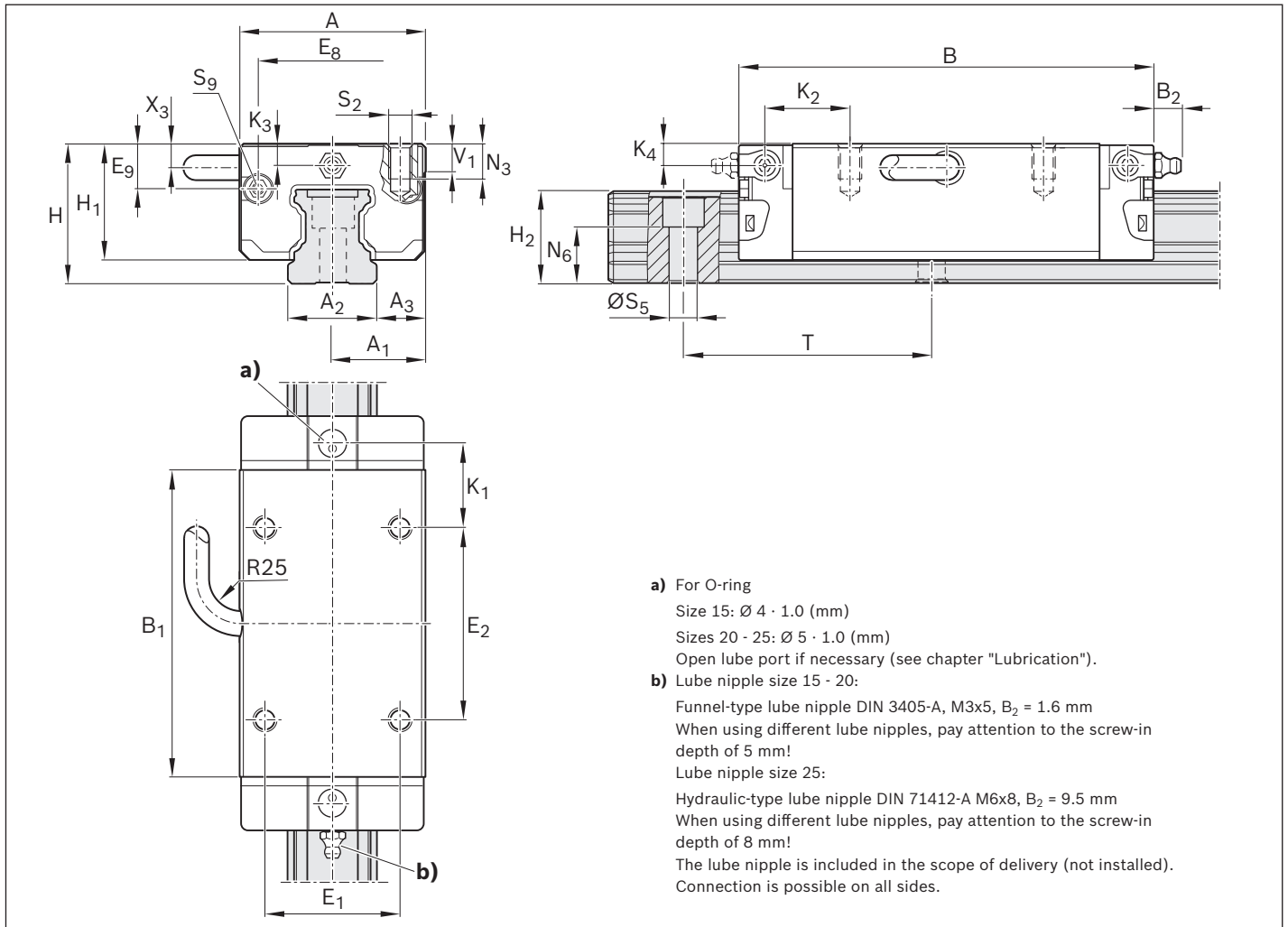

Size	Dimensions (mm)																			
	A	A ₁	A ₂	A ₃	B ^{+0,5}	B ₁	E ₁	E ₂	X ₃	E ₈	E ₉	H	H ₁	H ₂ ¹⁾	H ₂ ²⁾	K ₁	K ₂	K ₃	K ₄	
15	34	17	15	9.5	72.6	53.6	26	26	4.25	24.55	6.70	24	19.90	16.30	16.20	17.20	18.80	3.20	3.20	
20	44	22	20	12.0	91.0	65.6	32	50	5.90	32.50	7.30	30	25.35	20.75	20.55	14.80	14.80	3.35	3.35	
25	48	24	23	12.5	107.9	79.5	35	50	8.25	38.30	11.50	36	29.90	24.45	24.25	20.80	21.95	5.50	5.50	

Size	Dimensions (mm)									Mass (kg)	Load ratings (N)		Load moments (Nm)			
	N ₃	N ₆ ^{±0,5}	S ₂	S ₅	S ₉	T	V ₁	m	C		F _{max}	M _t	M _{t,max}	M _L	M _{L,max}	
15	6.0	10.3	M4	4.5	M2,5x3,5	60	5.0	0.20	12 800	4 270	120	40	120	40		
20	7.5	13.2	M5	6.0	M3x5	60	6.0	0.45	29 600	9 870	380	130	340	110		
25	9.0	15.2	M6	7.0	M3x5	60	7.5	0.65	37 300	12 430	530	180	530	180		

1) Dimension H₂ with cover strip
 2) Dimension H₂ without cover strip

SNH (Slimline, normal, high)

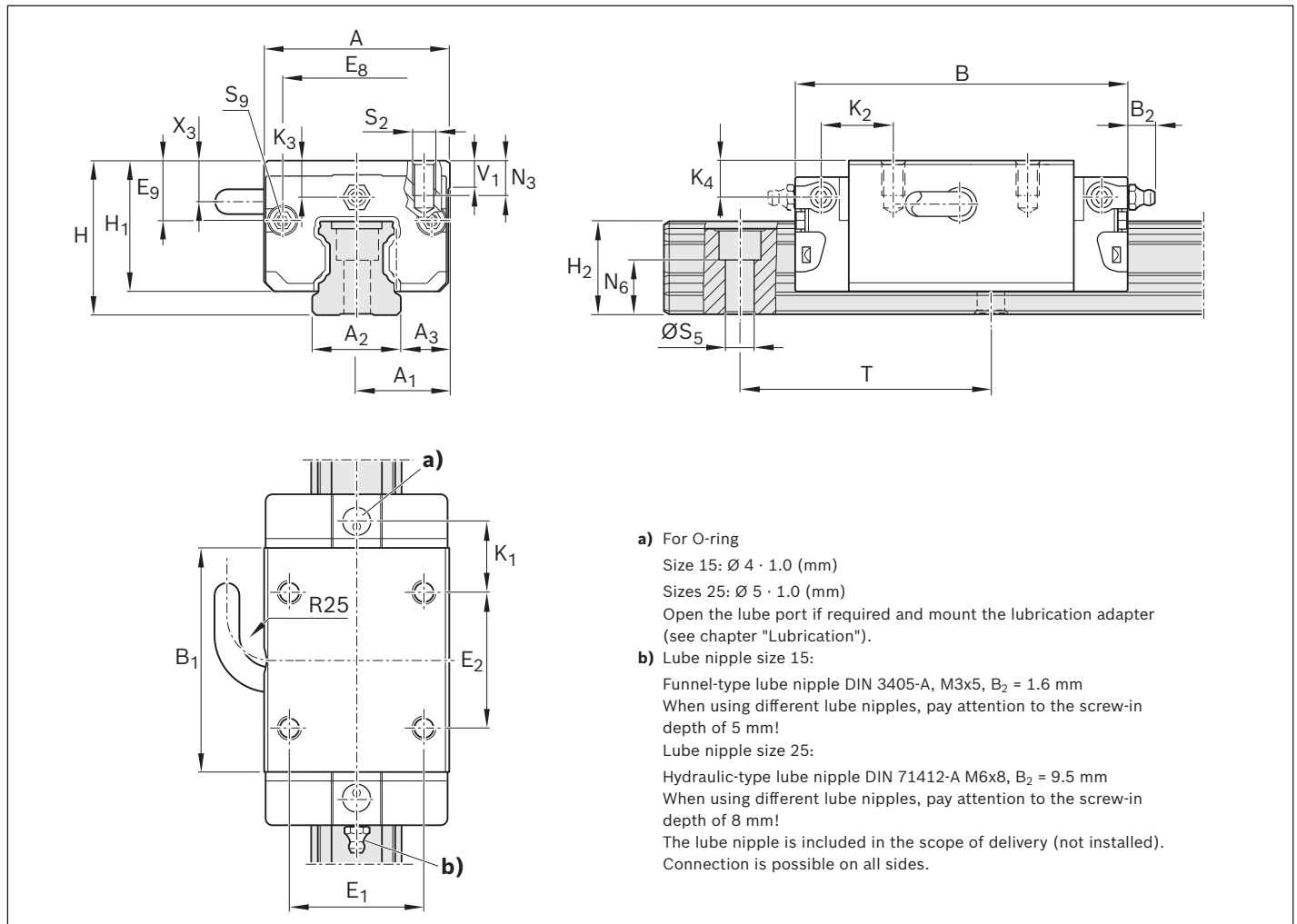

Size	Dimensions (mm)																			
	A	A ₁	A ₂	A ₃	B ^{+0,5}	B ₁	E ₁	E ₂	X ₃	E ₈	E ₉	H	H ₁	H ₂ ¹⁾	H ₂ ²⁾	K ₁	K ₂	K ₃	K ₄	
15	34	17	15	9.5	58.2	39.2	26	26	8.3	24.55	10.70	28	23.90	16.30	16.20	10.00	11.60	7.20	7.20	
25	48	24	23	12.5	86.2	57.8	35	35	12.5	38.30	15.50	40	33.90	24.45	24.25	17.45	18.60	9.50	9.50	

Size	Dimensions (mm)							Mass (kg)	Load ratings (N)		Load moments (Nm)			
	N ₃	N ₆ ^{±0,5}	S ₂	S ₅	S ₉	T	V ₁		m	C	F _{max}	M _t	M _{t,max}	M _L
15	6.0	10.3	M4	4.5	M2,5x3,5	60	5.0	0.20	9 860	3 290	95	30	68	20
25	9.0	15.2	M6	7.0	M3x5	60	7.5	0.60	28 600	9 530	410	140	290	100

1) Dimension H₂ with cover strip

2) Dimension H₂ without cover strip

SLH (Slimline, long, high)

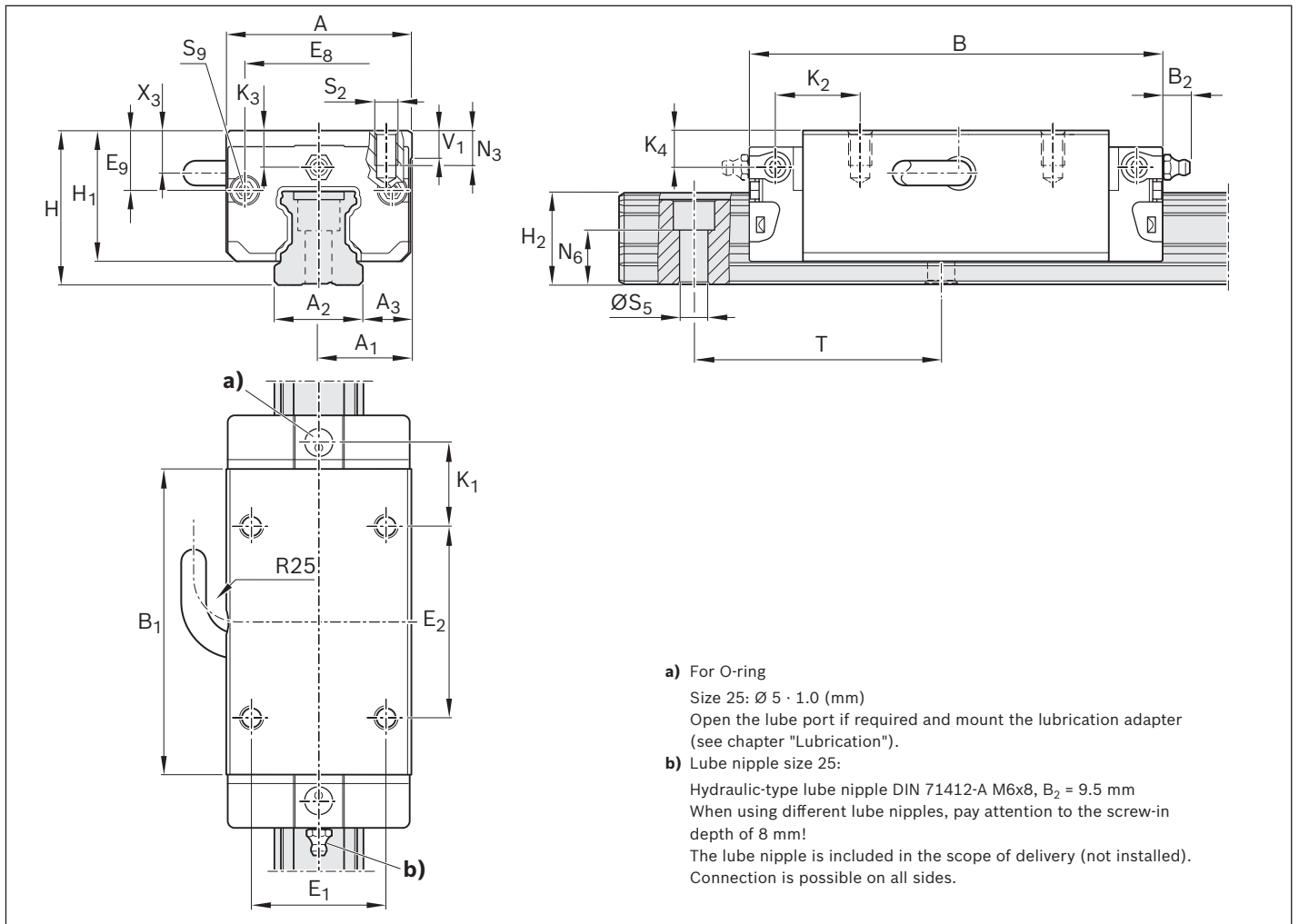

Size	Dimensions (mm)																			
	A	A ₁	A ₂	A ₃	B ^{+0,5}	B ₁	E ₁	E ₂	X ₃	E ₈	E ₉	H	H ₁	H ₂ ¹⁾	H ₂ ²⁾	K ₁	K ₂	K ₃	K ₄	
25	48	24	23	12.5	107.9	79.5	35	50	12.2	38.30	15.50	40	33.90	24.45	24.25	20.80	21.95	9.50	9.50	

Size	Dimensions (mm)							Mass (kg)	Load ratings (N)		Load moments (Nm)			
	N ₃	N ₆ ^{±0,5}	S ₂	S ₅	S ₉	T	V ₁		C	F _{max}	M _t	M _{t,max}	M _L	M _{L,max}
25	9.0	15.2	M6	7.0	M3x5	60	7.5	0.80	37 300	12 430	530	180	530	180

1) Dimension H₂ with cover strip
 2) Dimension H₂ without cover strip

Ball guide rail for IMScompact

Product overview and type key, ball guide rails

Measuring ball guide rails are available as one-piece (up to 6,000 mm) and multi-piece (butted) version (up to 17,800 mm).

Short type designation / ordering code for IMScompact ball guide rail:

I	M	S	C	-	K	S	A	-	0	2	0	-	S	N	S	-	P	-	M	A	-	M	T	-	1	-	R	D	-	2	0	-	D	-	1	7	8	0	0	
									1				2				3			4			5			6			7			8			9					10

1 Size

Characteristic	Name
015	Size 15
020	Size 20
025	Size 25

3 Accuracy class

Characteristic	Name
P	Precision
H	High

5 Cover

Characteristic	Name
MT	Magnetic strip, strip clamp
00 ¹⁾	without

7 Coding

Characteristic	Name
RD	Distance-coded reference marks

9 Documentation

Characteristic	Name
D	Standard

¹⁾ The magnetic strip may also be ordered separately – see accessories

2 Format

Characteristic	Name
SNS	Slimline, normal, standard height

4 Fastening

Characteristic	Name
MA	Bolting from above

6 Number of sections

Characteristic	Name
1	1-piece
2	2-piece
...	...
8	8-piece

8 Accuracy scale

Characteristic	Name
20	±20 µm/m

10 Overall length

Characteristic	Name
$L_{\min} \leq L \leq 17800$	mm

Ball guide rail for IMScompact

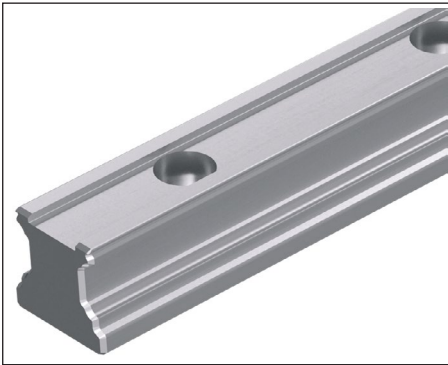

Without magnetic strip: Option 00

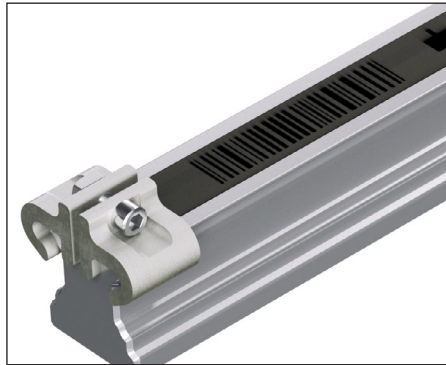

With magnetic strip and strip clamp Option MT

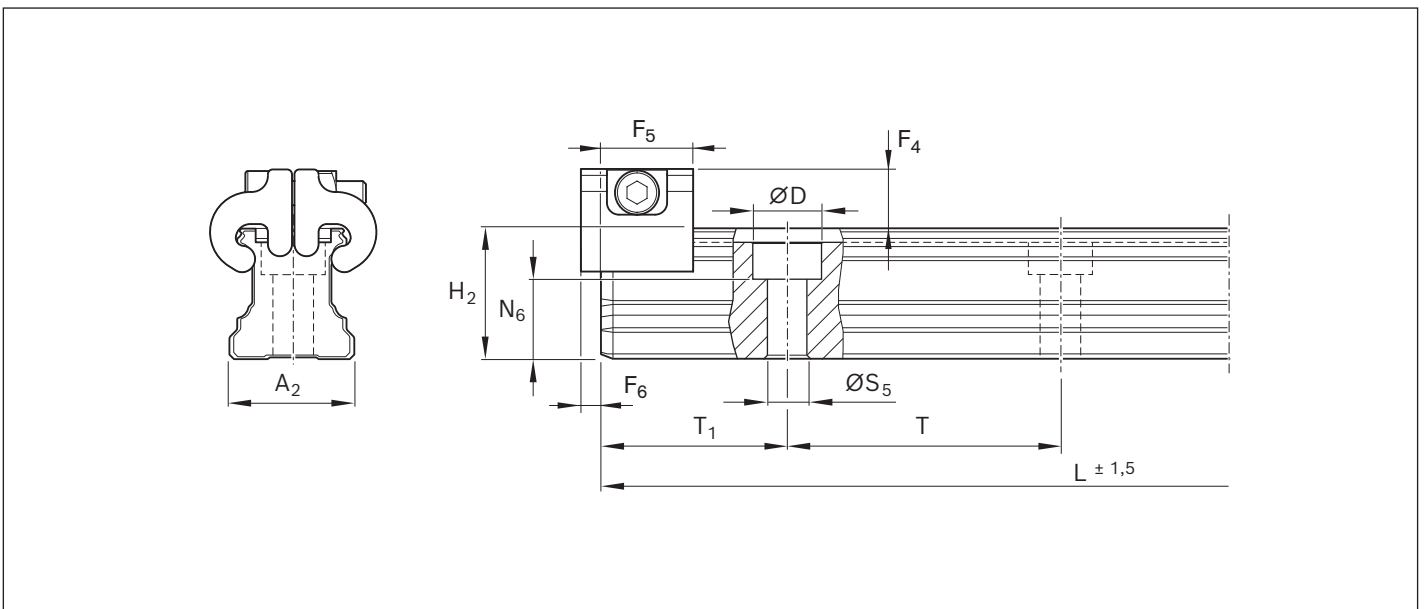

Size	Dimensions (mm)													Mass m (kg/m)
	A ₂	D	H ₂ ¹⁾	L _{max} ²⁾	N ₆ ^{20,5}	S ₅	T	T _{1 min}	T _{1S} ³⁾	T _{1 max}	F ₄	F ₅	F ₆	
15	15	7.4	16.20	3 836	10.3	4.5	60	12	28.0	48	7.3	12.0	2.0	1.4
20	20	9.4	20.55	3 836	13.2	6.0	60	13	28.0	47	7.1	12.0	2.0	2.4
25	23	11.0	24.25	3 836	15.2	7.0	60	13	28.0	47	8.2	13.0	2.0	3.2







1) Dimension H₂ without cover strip

2) For sizes 20 - 25, ball guide rails up to 5816 mm are available upon request.

3) Preferred dimension T_{1S} with tolerances ± 0.75 recommended.

Accessories

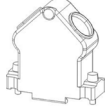
Cables and electrical accessories

	For EC interfaces	3 m	5 m	10 m	20 m	100 m
	1 Vss	R051704308	R051704309	R051704310	R051704311	
	TTL	R051704312	R051704313	R051704314	R051704315	
	SSI	R051704144	R051704784	R051705002	R051705003	
	Raw cable PUR orange, 5x2x0.09 mm					R168395000
	INS0760, encoder connector (pin)	R911297361				
	INS0761, encoder connector (bush)	R911297341				

Additionally, freely selectable cable manufactures are available.

Short type designation / ordering code for ready-made IMScmpact extension cable:

I	M	S	C	-	V	L	-	I	9	-	E	-	5	0	,	0
									1		2					3

1 Cable end 1 (interface)

Characteristic	Name
I9	1Vss/15-pin sub-D, female connector
I4	TTL/15-pin sub-D, female connector
S1	SSI/15-pin sub-D, female connector
00	Without, open cable end

2 Cable end 2 (connector type)

Characteristic	Name
E	15-pin sub-D, pins, 1Vss/EC
F	15-pin sub-D, pins, TTL/EC
G	SSI/15-pin sub-D, female connector
O	Without, open cable end

3 Cable length

Characteristic	Name
1 ≤ L ≤ 75	m

In the type key, it is impossible to combine different signal types with characteristics 1 and 2.

E.g.: Combinations of cable end 1 = I9 and cable end 2 = F impossible.

As leading manufacturer of electric drives, controllers and control units, Rexroth offers a great selection of accessories, available under www.boschrexroth.com.

Filter connector

For an EMC environment at the place of installation, that is difficult or hard to evaluate, for the IMScompact with absolute interface (see requirements on the voltage supply).

- ▶ For use between measuring system and evaluating unit
- ▶ DSUB 15pol adapter plug
- ▶ Assignment see “Electrical interfaces”
- ▶ Housing ABS metalized, UL94V-0

Order number R168393010

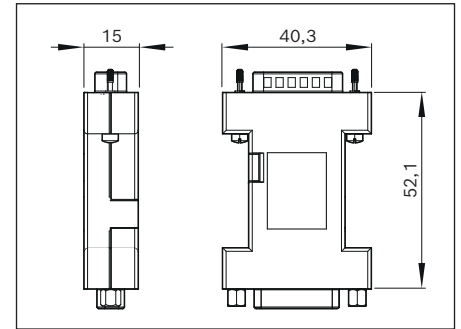

Magnetic strips



Magnetic strips can be ordered cut-to-size or in a package with a length of 17.8 m. As an order length of 17.5 m, an entire roller with a total length of 17.8 m is supplied.

Size	Order number	Length (m)
15	R168318002	17.8
20	R168388002	17.8
25	R168328002	17.8

Short type designation / ordering code for IMScompact magnetic strip:

I	M	S	C	-	M	T	-	0	2	0	-	R	D	-	2	0	-	1	7	8	0	0
								1				2			3							4

1 Size	Characteristic	Name
	015	Size 15
	020	Size 20
	025	Size 25

2 Coding	Characteristic	Name
	RD	Distance-coded reference marks

3 Accuracy scale	Characteristic	Name
	20	±20 µm/m

4 Overall length	Characteristic	Name
	$L_{min} \leq L \leq 17\,800$	mm

Pole search film



Name	Order number
Pole search film	R168399000

With the pole search film, the magnetization of the magnetic strip can be checked.

Cover strip



The cover strips for IMScopact have different material properties than the standard cover strips for ball rail systems made of steel. To ensure the absolute measuring function, only cover strips dedicated for IMScopact may be used.

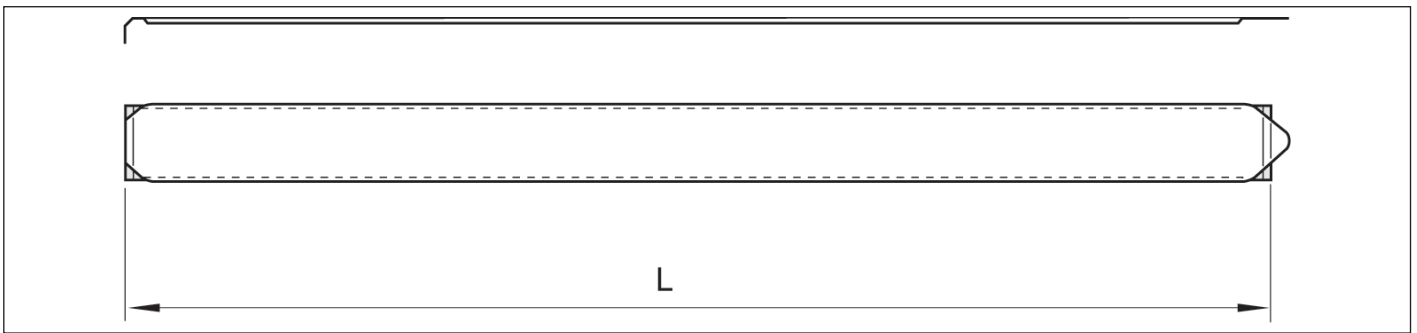

Short type designation / ordering code for cover strip with snap fit:

I	M	S	C	-	F	S	T	-	0	2	0	-	1	7	8	0	0
										1		2					

1 Size	
Characteristic	Name
015	Size 15
020	Size 20
025	Size 25

2 Overall length	
Characteristic	Name
$L_{min} \leq L \leq 17\,800$	mm

Strip clamps

Associated aluminum strip clamps can be ordered under the following material numbers. The pieces are packed as set (2 strip clamps with related screw bolting).

Size	Order number	Mass (g)
15	R161913950	11
20	R161983950	13
25	R161923950	14

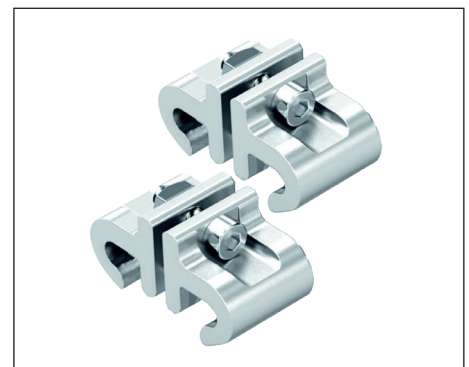

Mechanical accessories

From the standard guide rail to the full product range of runner blocks including comprehensive accessories – the proven Rexroth BSHP program is compatible with IMSScompact. Special feature: braking and clamping units as well as the runner blocks of all versions and accuracy classes can also be operated on the measuring system rail.

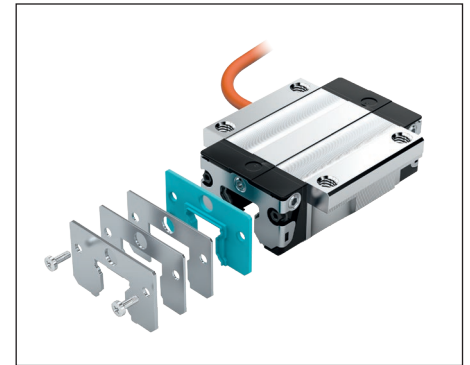

Position display

For simple applications, e.g. stop adjustment and length measurement, for the direct display of the position value, a compact display unit is available. This unit can be connected to the TTL version (option I4) of the IMSScompact.

Characteristics of the position display R168393000:

- ▶ 7-digit LCD display, color: blue, character height: 10 mm, including sign and measuring unit
- ▶ Easy snap-in mounting in panel cut-out 68x45 mm
- ▶ Offset function
- ▶ Switching between relative and absolute dimension
- ▶ Actual value storage
- ▶ Protection class IP 54 (front), IP40 (rear)
- ▶ Connection of the IMSScompact to the position display by means of
 - a.) an adapter cable R348112705 (DSUB 15-pin to DSUB 9-pin)
 - b.) DSUB Breakout Box
- ▶ Voltage supply 24VDC (power supply unit not included in the scope of delivery)



	Order number	Length (m)
Position display	R168393000	-
Adapter cable	R348112705	0.55
DSUB Breakout Box	R348112905	-

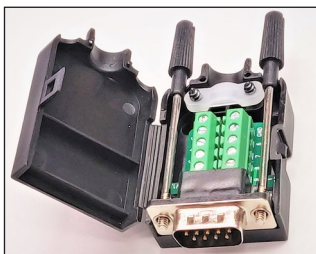
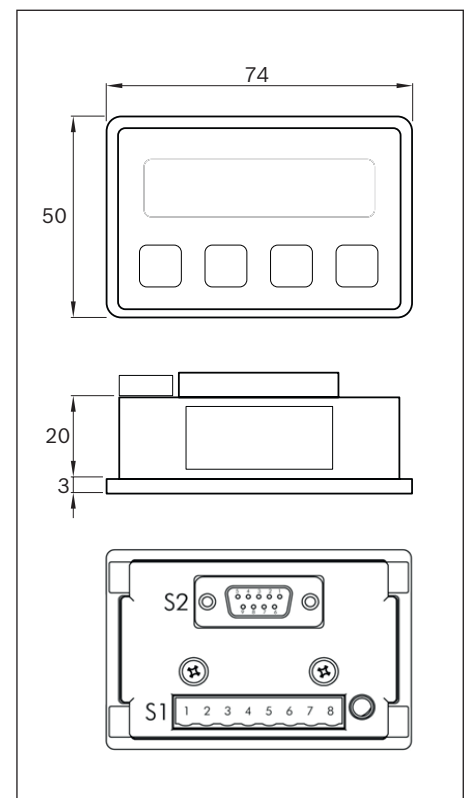

DSUB Breakout Box



[Position display instructions](#)

Further information

Safety instructions

Intended use

Rail Systems are linear guides capable of absorbing forces from all transverse directions and moments about all axes. Rail Systems are intended exclusively for guiding and positioning tasks when installed in a machine. The integrated position measurement system (IMS for short) is an assembly. The IMS consists of components for precise linear movements and incremental measurements of linear displacement. The product may be used in accordance with the technical documentation (product catalog) for the following purposes:

- ▶ As a direct linear position measurement system in industrial environments (woodworking, laser welding, laser cutting, metal cutting and metal forming machine tools).
- ▶ As a linear encoder in applications with a linear motor.
- ▶ In interpolating axes in machine tools.
- ▶ In measuring machines within the scope of the achievable accuracy.
- ▶ For connection to display units, evaluation electronics for PCs and drive controllers.

The product is intended exclusively for professional use and not for private use. The intended use also includes having read and understood the product documentation completely, in particular these "Safety instructions". The product is exclusively intended for incorporation into a machine or system or for assembling with other components to build a final machine or system. Misuse Using the product in any other way than as described under "Intended use" is considered to be misuse and is therefore not permitted. The product may only be used in applications or environments constituting a hazard to the health and life of persons if this use – for example, in potentially explosive atmospheres covered by ATEX regulations – has been expressly specified and permitted in the product documentation. Bosch Rexroth AG will not accept any liability for damage caused by misuse of the product. The risks associated with any misuse of the product shall be borne by the user alone.

Misuse of the product includes:

- ▶ The transport of persons
- ▶ Use in potentially explosive atmospheres
- ▶ Use in direct contact with unpacked foodstuffs
- ▶ Use in liquids
- ▶ Use as a safety component, either mechanical or electrical
- ▶ Use in environments with increased radioactivity

General safety instructions

- ▶ The safety rules and regulations of the country in which the product is used must be observed.
- ▶ All current and applicable accident prevention and environmental regulations must be adhered to.
- ▶ The product may only be used when it is in technically perfect condition.
- ▶ The technical data and environmental conditions stated in the product documentation must be complied with.
- ▶ The product must not be put into service until it has been verified that the final product (for example a machine or system) into which the product has been installed complies with the country-specific requirements, safety regulations and standards for the application.
- ▶ Rexroth Rail Systems may not be used in zones with potentially explosive atmospheres as defined in the ATEX Directive 94/9/EC.
- ▶ Rexroth Rail Systems must never be altered or modified. The user may only perform the work described in the "Quick User Guide" or the "Mounting instructions for ball/ roller rail systems".
- ▶ The product is never allowed to be disassembled.

- ▶ At high travel speeds a certain amount of noise is caused by the product. If necessary, appropriate measures should be taken to protect hearing.
- ▶ The special safety requirements for specific sectors (e.g. crane construction, theaters, food technology) set forth in laws, directives and standards must be complied with.
- ▶ In all cases, the provisions of the following standard should be noted and followed: DIN 637, Safety regulations for dimensioning and operation of profiled rail systems with recirculating rolling elements.
- ▶ The runner block and guide rail shall be generally and sufficiently grounded. Danger to life in the event of energized components!

Directives and standards

Rexroth Rail Systems are suitable for dynamic linear applications requiring reliability and high precision. The machine tool industry and other sectors must observe a series of standards and directives. These requirements can vary significantly worldwide. It is therefore essential to understand the legislation and standards that apply in each particular region.

DIN EN ISO 12100

This standard describes the safety of machinery – general principles for design, risk assessment and risk reduction. It gives a general overview and contains a guide to the major developments governing machines and their intended use.

Directive 2006/42/EC

The European machinery directive describes the basic safety and health requirements for the structural design and manufacture of machinery. The manufacturer of a machine or his authorized representative has a duty to ensure that a risk assessment has been performed in order to determine the health and safety requirements which have to be fulfilled for that machine. The machine must be designed and built taking into account the results of the risk assessment.

Directive 2001/95/EC

This directive covers general safety requirements for any product placed on the market and intended for consumers, or likely to be used by consumers under reasonably foreseeable conditions, including products that are made available to consumers in the context of service provision for use by them.

Directive 85/374/EEC

This directive concerns the liability for defective products and applies to industrially manufactured movable objects, irrespective of whether or not they have been incorporated into another movable or immovable object.

REGULATION (EC) No. 1907/2006 (REACH)

This regulation relates to restrictions on the marketing and use of certain dangerous substances and preparations. "Substances" means chemical elements and their compounds as they occur in the natural state or as produced by industry. "Preparations" means mixtures or solutions composed of two or more substances.

DIN 637

Ball bearings – safety regulations for dimensioning and operation of profiled rail systems with rolling element circuit (see the catalog "Ball rail systems").

EMC directive

This directive refers to the electromagnetic compatibility of electrical and electronic products.

RoHS directive

This directive concerns the restriction of the use of certain hazardous substances in electrical and electronic equipment. It regulates the use and the placing on the market of hazardous substances in electrical appliances and electronic construction elements.

- Always handle the measuring system with great care!

See detailed instruction for mounting:

R320103196 IMScompact instructions

R320103195 IMScompact package insert

R320103179 IMScompact position display

R320103885 Instructions for profiled rail systems

For more information on maintenance and lubrication, see the respective chapters in the catalog "Ball rail systems BSHP".

Configurators, calculation tools, eShop, CAD models

All order information, comfortable configuration and calculation tools as well as an e-shop for direct orders are provided at: [Online catalog](#)



Bosch Rexroth Linear Motion Technology homepage

<https://www.boschrexroth.com/en/xc/products/product-groups/linear-motion-technology/index>

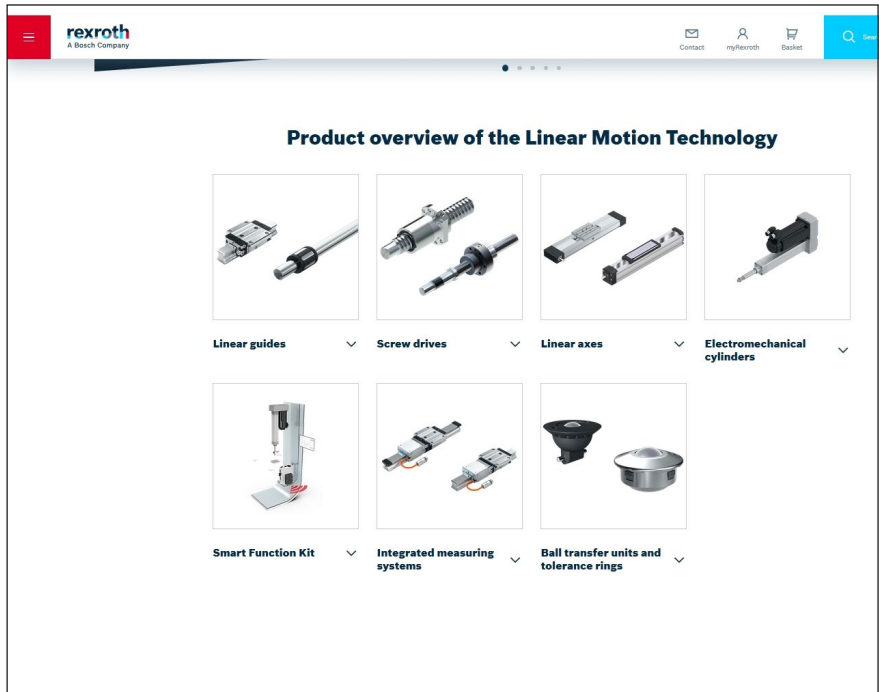

Configurators and tools

<https://www.boschrexroth.com/en/xc/products/engineering/econfigurators-and-tools/econfigurators>

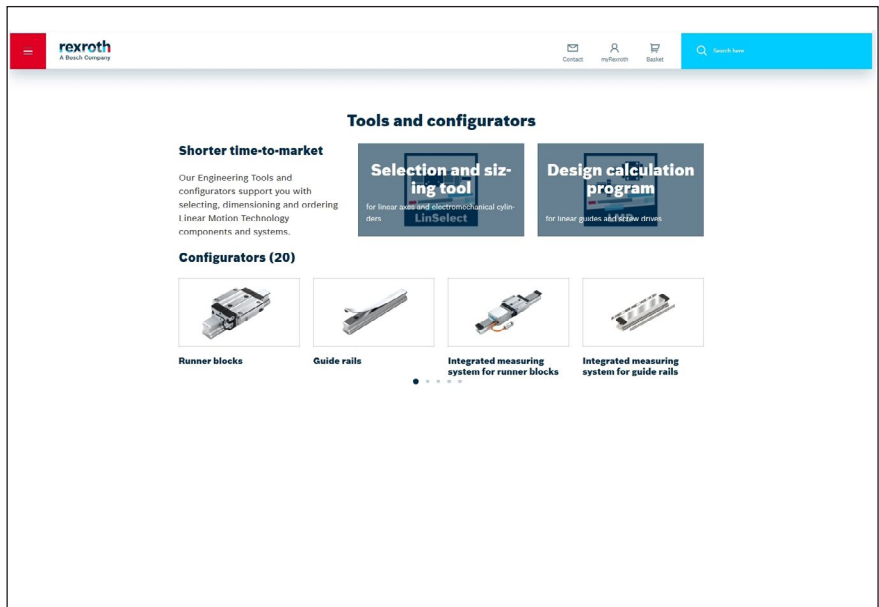

GoTo Europe

<http://www.boschrexroth.com/goto>

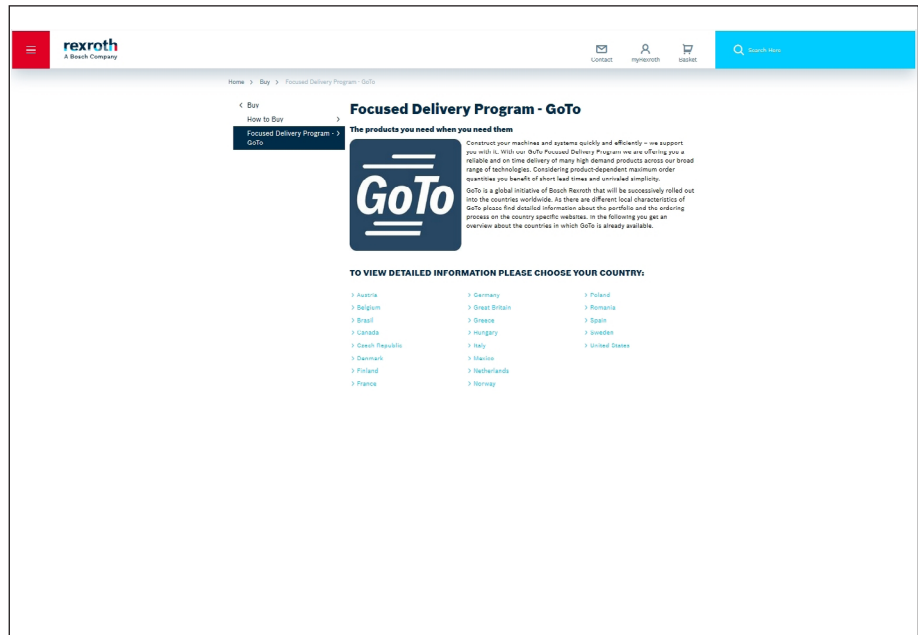

How-to: Linear Motion Technology

<https://www.youtube.com/playlist?list=PLRO3LeFQeLyMF6evW4E7kR93JHzpJIV4r>

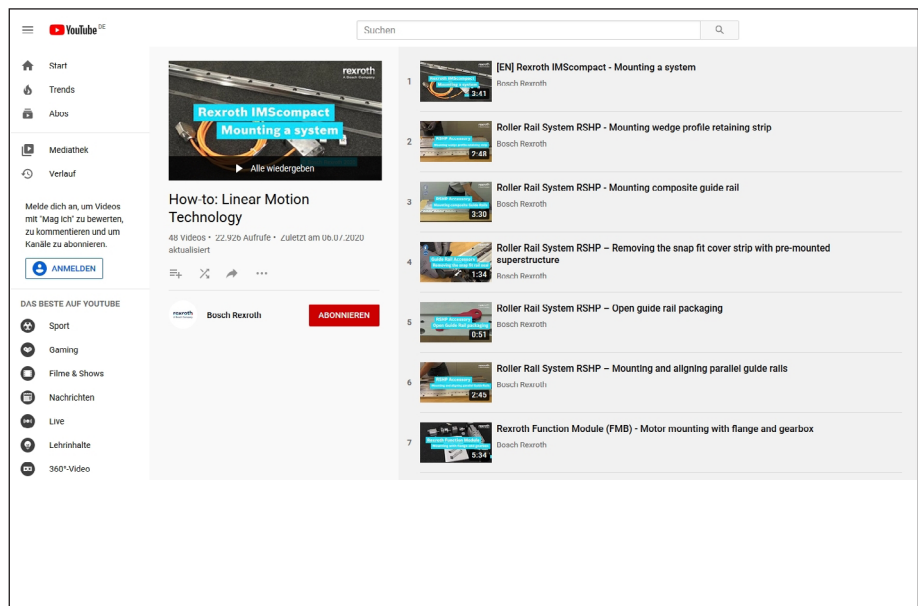

Service

<https://www.boschrexroth.com/en/xc/products/product-groups/linear-motion-technology/service-linear-motion-technology>

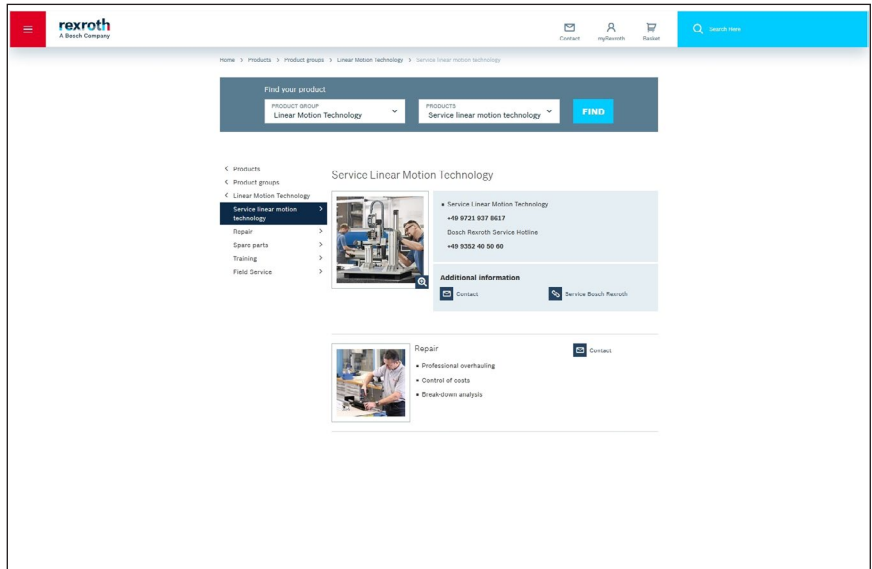

Training

<https://www.boschrexroth.com/en/xc/training/training>

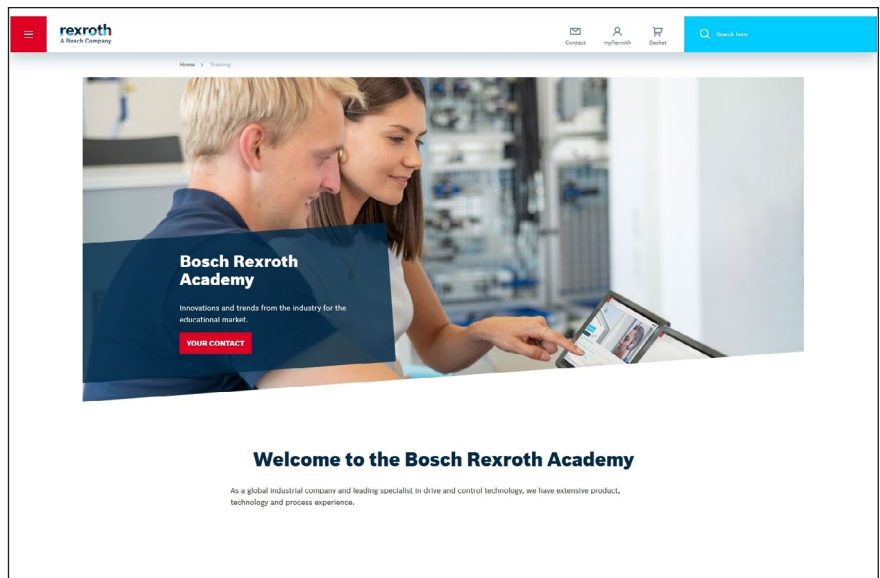

DISTRIBUTED BY
AUTOMATION CONTROL
ROBOTICS > DRIVES > SYSTEMS
EC 13722



SERVICE & SUPPORT

Wangara, WA +61 8 6314 1111
support@automation-control.com.au
automation-control.com.au