



Process Weigher MW65A

Technical Information ALL

ModWeigh

FEATURES

- Modbus communications (independent RS232 and RS485 ports)
- USB Host & Device (memory stick & PC)
- Field software upgrades
- 12-24Vdc power supply
- Overall accuracy better than 0.01%

MD2,MP2 INDICATOR

- IP54 Facia
- 2.8" (70mm) colour LCD
- 320 x 240 pixels
- Polyester film tactile keypad
- 4-20mA output, 1 digital input & 2 digital outputs

MO3 I/O for MP2

- 4 Digital inputs
- 4 Digital outputs
- 4-20mA input (or 0-10V)
- 4-20mA output

MD1,MP1 INDICATOR

- IP65 Facia
- 4.3" (109mm) colour LCD
- 480 x 272 pixels
- Silicone tactile keypad

MT1 TRANSMITTER

- Size 136 x 66 x 50mm
- Optional removable P-Module holds calibration settings

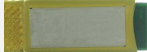

MT3 TRANSMITTER

- Size 136 x 66 x 50mm

MR1 I/O

- Size 136 x 66 x 30mm
- 8 Digital inputs
- 8 Digital outputs
- 4-20mA input (or 0-10V)
- 4-20mA output x 2
- Pulse output

Application

The ModWeigh MW65 Process Weigher Systems are state of the art weighing instruments that can be used with most loadcell based weighing systems.

The process weigher controls the filling and discharge of product in and out of a weigh hopper. The fill/discharge cycle runs for a period of time and the material throughput is totalised and flowrate measured. A batch weight can be set to stop the cycle once a predetermined weight is reached. A flowrate setpoint can be set causing the controller to slow the process to achieve the required flowrate.

ModWeigh Display

The ModWeigh Weight Indicator display are separate products which may be used with the ModWeigh family of products for display of weight, setup and calibration. It has a graphics display with easy to use menu selection of settings.

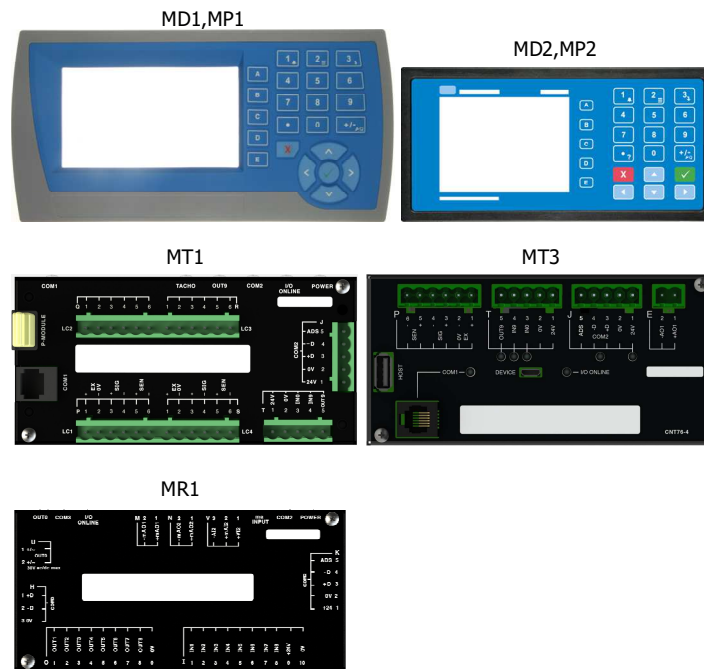
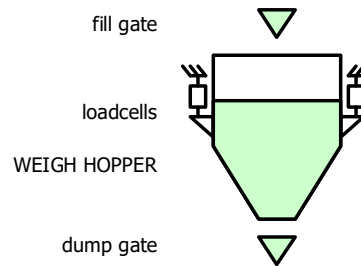

Features

Basic

Units & Resolution

The units for each variable type (weight etc.) can be selected from a list of metric and imperial units. The resolution of each variable type can be adjusted, this alters the count by e.g 100kg displayed in 0.2kg increments.

OIML Design

The instrument is designed to OIML standards.

Language Support

Support is available for the following languages: English, Chinese, Korean, German, Spanish, French, Italian and Polish.

Inputs

Digital Inputs INx

The digital inputs are programmable to a range of function including 'acquire zero', 'print' etc.

Corner Adjustment (MT1 only)

The input sensitivity can be individually adjusted for up to 4 loadcells, allowing differences in loadcell sensitivities to be corrected.

Four Loadcell Inputs (MT1 only)

Separate inputs are available for 4 loadcells allowing the signal of each to be monitored separately. This provides an aid for load balancing across loadcells and also for fault finding.

Signal Filtering

Filtering for the weight can be adjusted to get the optimum compromise between reduction of plant vibration and response speed.

Internal Signals

Limits

The high and low limits have adjustable setpoints which may be programmed to operate on any internal signal.

Event Collection

Process events are collected for operation with external equipment (PLCs etc.)

Memory Storage

Allows a group of settings to be stored or recalled from memory. This can be used for example to store settings for different products. There are 20 memory locations with up to 4 settings in each.

Outputs

Analog I/O Scaling

The analog output range can be adjusted over the full 0 to 20mA range. The output will drive to a slight negative mA, allowing a live zero to be achieved when using a 0 to 20mA range. A voltage output is easily produced by connecting a resistor to the output.

In addition the analog output signal is selectable to come from any internal signal in the instrument e.g weight, flowrate etc.

Digital Outputs OUTx

The digital outputs are programmable to operate from any internal signal. These signals include the digital input states, status conditions (running, paused etc) and any fault conditions that are detected. This makes it easy connect into other systems.

Communications & Display

Comms

RS232 and RS485 ports are available. These are used to connect ModWeigh units together and also to connect to other systems. The protocol is either ASCII output for example to drive a printer or Modbus for interactive communications. Baud rates and node addresses are programmable.

USB host and device ports are available. This allows for example PC and USB flash drive connectivity. It can be used to update the units software, for data logging and for recording of the units settings.

Printouts & Macros

Printouts can be triggered by a key press or set up to occur at set times during the day or week. Data may also be output continuously for data collection purposes. Data is output on the COM1 RS232 port. The content of the printouts is fully programmable using Macros.

Macros are programs used to customise printouts, but can also be used to perform arithmetic calculations. The Macro language also contains conditional terms for more advanced programming.

Display Customisation

Locks may be set to prevent unauthorised use of the operator keys and restrict entry to the operator menu. The keys are individually lockable and optionally a passcode can be used to allow authorised op-

erators to use the keys. Alternatively a confirmation of the key action can be requested. The operator MENU can be customised to make additional settings or signals available to the operator.

The contents of the main display can be set to suit any condition, from a comprehensive display showing all operating parameters to a simple display showing the basic signals.

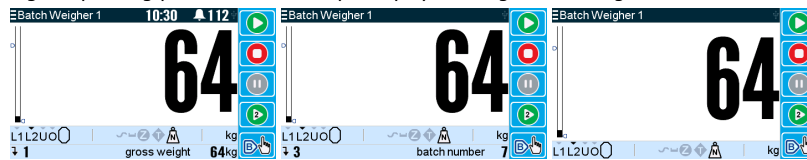

Computer Connectivity

ModWeigh instruments can be connected to a computer with an RS232 connection. Data can be sent to the PC at a preset rate. The data sent can be set up using macros.

There is also a command line interface which allows any of the settings and data to be read or written.

IO Summary

	Digital Inputs (includes pulse input)	Digital Outputs (includes pulse output)	Isolated Pulse Output	Isolated 4-20mA Inputs	Isolated 4-20mA Outputs	RS232	RS485	USB Host (Memory Stick)	USB Device (PC Cable)	Corner adjustment and balancing for 4 loadcells	Trade approvals (MW95, MW96)
MP2	1	2	1	0	1	1	1	1	1	*	*
MP2,MO3	1+4	2+4	1	1	1+1	1	1	1	1	*	*
MP1,MR1	1+8	9	1	1	2	2	1	1	1	*	*
MD1,MT1,MR1	2+8	1+9	1	1	2	2	2	1	1	✓	✓
MD2,MT1,MR1	2+8	1+9	1	1	2	2	2	1	1	✓	✓
MD1,MT3	2	1	0	0	1	2	1	1	1	*	*
MD2,MT3	2	1	0	0	1	2	1	1	1	*	*
MD1,MT3,MR1	2+8	8	1	1	3	2	1	1	1	*	*
MD2,MT3,MR1	2+8	8	1	1	3	2	1	1	1	*	*

Specifications

Loadcell Input AI1

Input Range	±4 mV/V (0-20mV)
Excitation	5 Vdc ±20 %, 250 mA maximum current
Signal processing rate	100 Hz (response time setting ≤ 0.5 s)
Input sensitivity	0.5 μV/division maximum
Zero range	±3 mV/V (±15 mV)
Zero drift	±0.02 μV+0.0005 % of deadload/°C typical
Span drift	±0.0005 %/°C typical
Non-linearity	<0.002 % of FS
Input noise	0.15 μVp-p typical
Filtering	0.04 s to 32.0 s response time adjustable
Sense voltage range	1-5 V

Analog Input AI2

4-20mA input resistance	<60 Ω
0-10V input resistance	>100 kΩ
Isolation	galvanically isolated to 50Vac

Analog Outputs AO1 & AO2

Output range	0 to 20 mA (-0.2 mA to 21 mA, includes standard 4-20mA)
Maximum load	1000Ω
Resolution	0.4 μA
Response time	Loadcell response time setting + 20 ms

Voltage output	Use an external resistor to convert mA to volts. For example 500Ω gives 10 V at 20 mA.
Non-linearity	<0.01 %
Drift	<2 μA/°C.
Isolation	independently galvanically isolated to 50Vac
High voltage	> 8 V
Low voltage	< 4 V
Maximum voltage	32 V
Input load	4 kΩ approximate

Digital Inputs INx

High voltage	> 8 V
Low voltage	< 4 V
Maximum voltage	32 V
Input load	6 kΩ approximate
Input type	PNP output sensors

Digital Outputs OUTx

Max output current	$\Sigma I_{IOx} < 0.25 \text{ A}$
Output voltage	same as supply voltage

Communications COM1, COM2 & COM3

COM1 Interface	RS232
COM1 Handshake	CTS can be enabled
COM2/COM3 Interface	RS485
Baud rates	9600, 19200, 38400, 57600, 115200 (230400 on COM2)
Settings	8 data bits, no parity, 2 stop bits (8-N-2)
Protocol	Modbus RTU (MWBUS on COM2)

General

IP Rating	IP20 (MD1,MP1 facia IP65) (MD2,MP2 facia IP54)
Operating temperature	-10 to 45 °C
Supply voltage	10 to 28 Vdc
Power MT1	1.0 to 2.2 W + P _{Tacho Excitation}
Power MT3	1.0 to 2.2 W + P _{Tacho Excitation}
Power MR1	1.5 to 2.5 W + P _{OUTx}
Power MD1	1.8 W
Power MP1	1.8 to 3.0 W
Power MD2	1.4 W
Power MP2	1.4 to 3.1 W
Power MP2 + MO3	3.4 to 5.0 W + P _{OUTx} + P _{Tacho Excitation}
MP2 Restrictions	P _{Loadcell Excitation} + P _{AO1} + P _{AO2} < 1.5 W I _{Supply} < 0.5 A

Dimensions

Following are the dimensions of the hardware items that make up the system.
The displays/processors are designed for panel mounting.

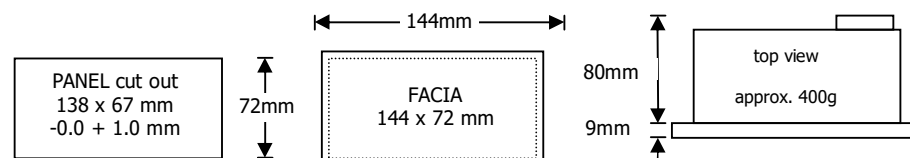
MD2 Display**MP2 Processor**

MD1 Display
MP1 Processor

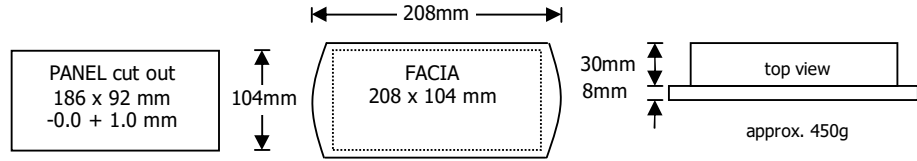

MT1 Transmitter

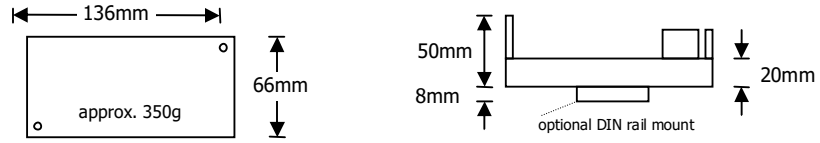
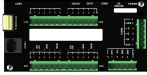

MT3 Transmitter

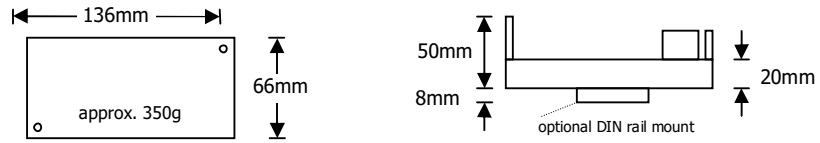

MR1 Remote IO

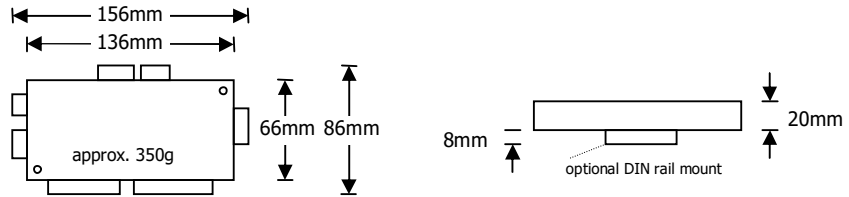

Connections

Connection Principles

ModWeigh instruments can be configured in many different ways to suit any given application. The display is normally located to suit an operator. The transmitter can be located in the field to reduce field wiring or can be located with the display for a more conventional approach. The I/O can conveniently be situated on a DIN rail in a cabinet.

Connection Diagram – MP2

Keep all wiring separated from mains wiring

Use shielded cable where indicated

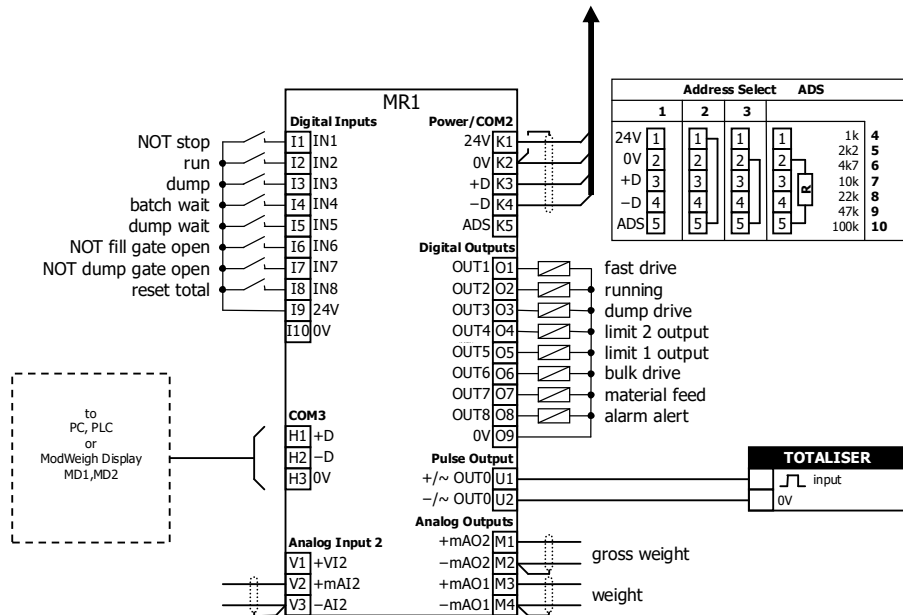
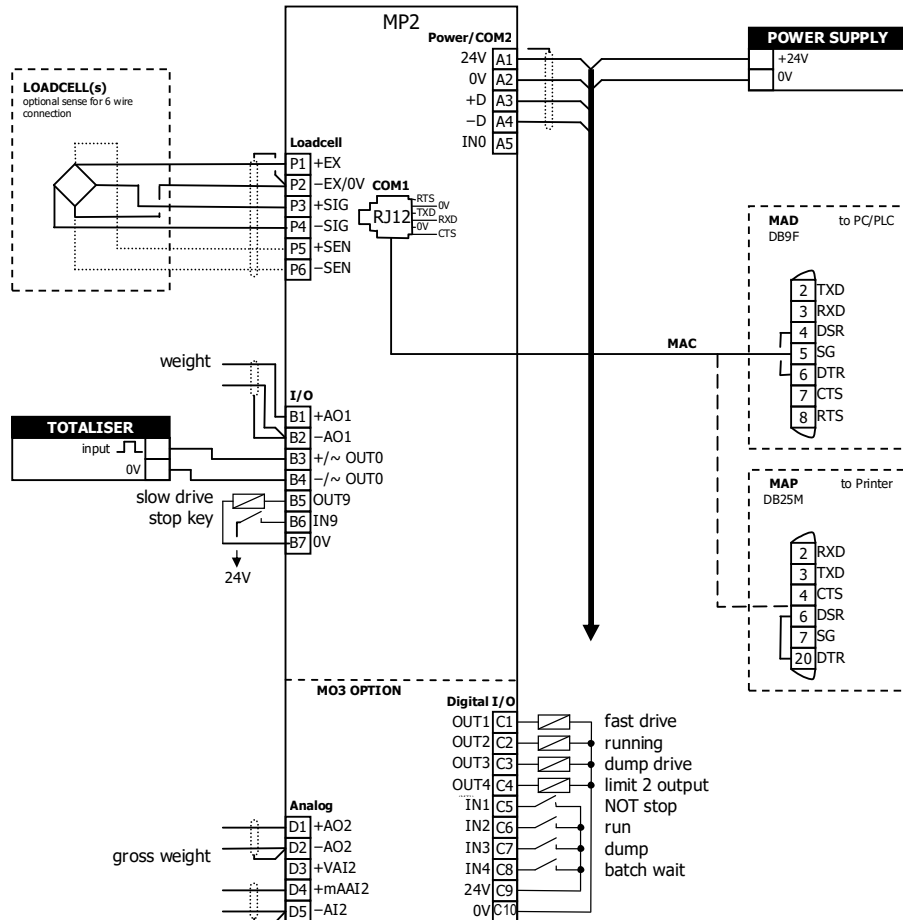

Connection Diagram – MP1

Keep all wiring separated from mains wiring

Use shielded cable where indicated

MP1 bus address set with setting (Q2522).

MR1 bus address set with ADS pin and must be same as MP1.

Fit an MAT terminator to each end of COM2 cable if length exceeds 50m.

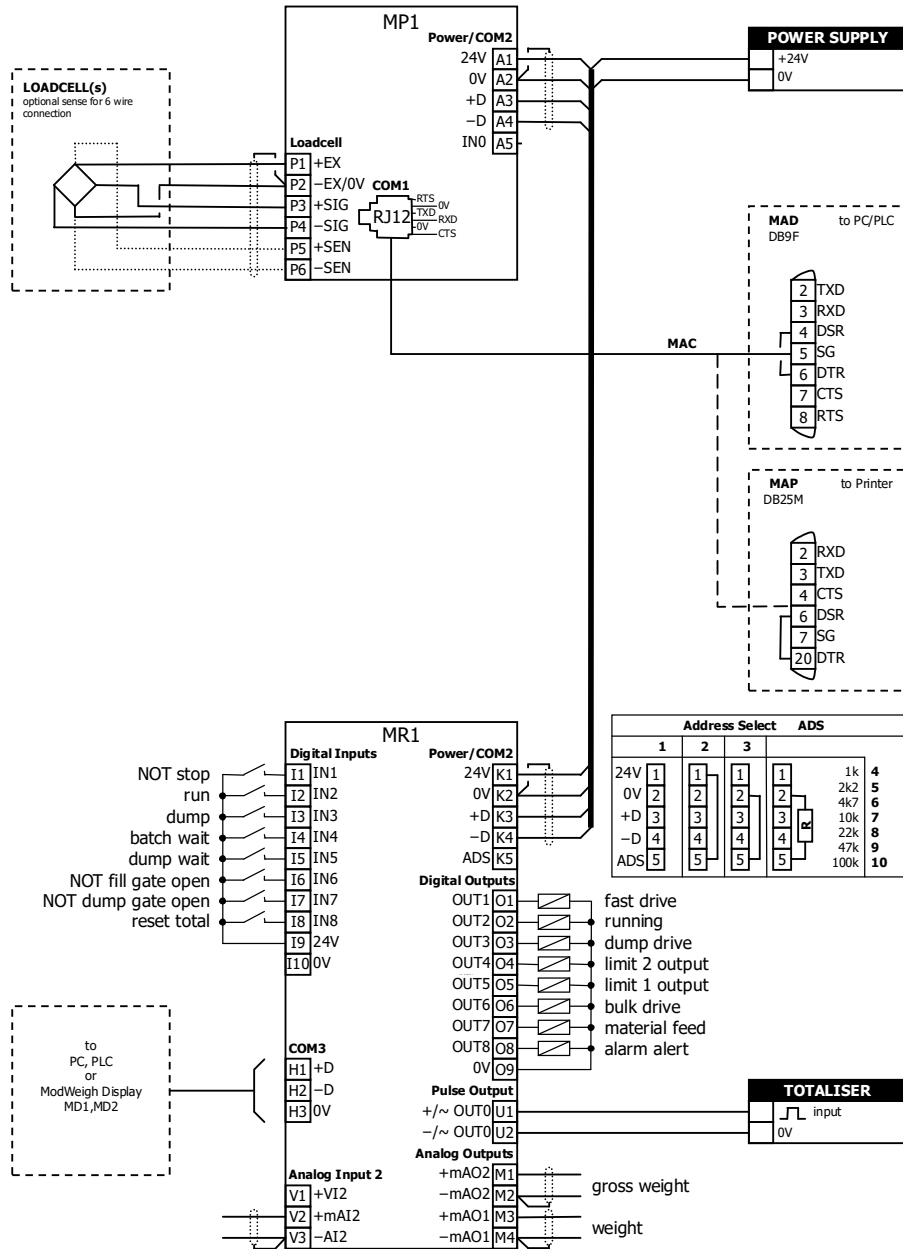

Connection Diagram – MT1

Keep all wiring separated from mains wiring.

Use shielded cable where indicated.

For individual loadcell sensitivity adjustment, use terminals P, Q, R and S.

Display and transmitter can alternatively be connected COM1 to COM1 using an MAC cable.

MT1 bus address set with ADS pin or a setting.

MR1 bus address set with ADS pin and must be same as MT1.

Fit an MAT terminator to each end of COM2 cable if length exceeds 50m.

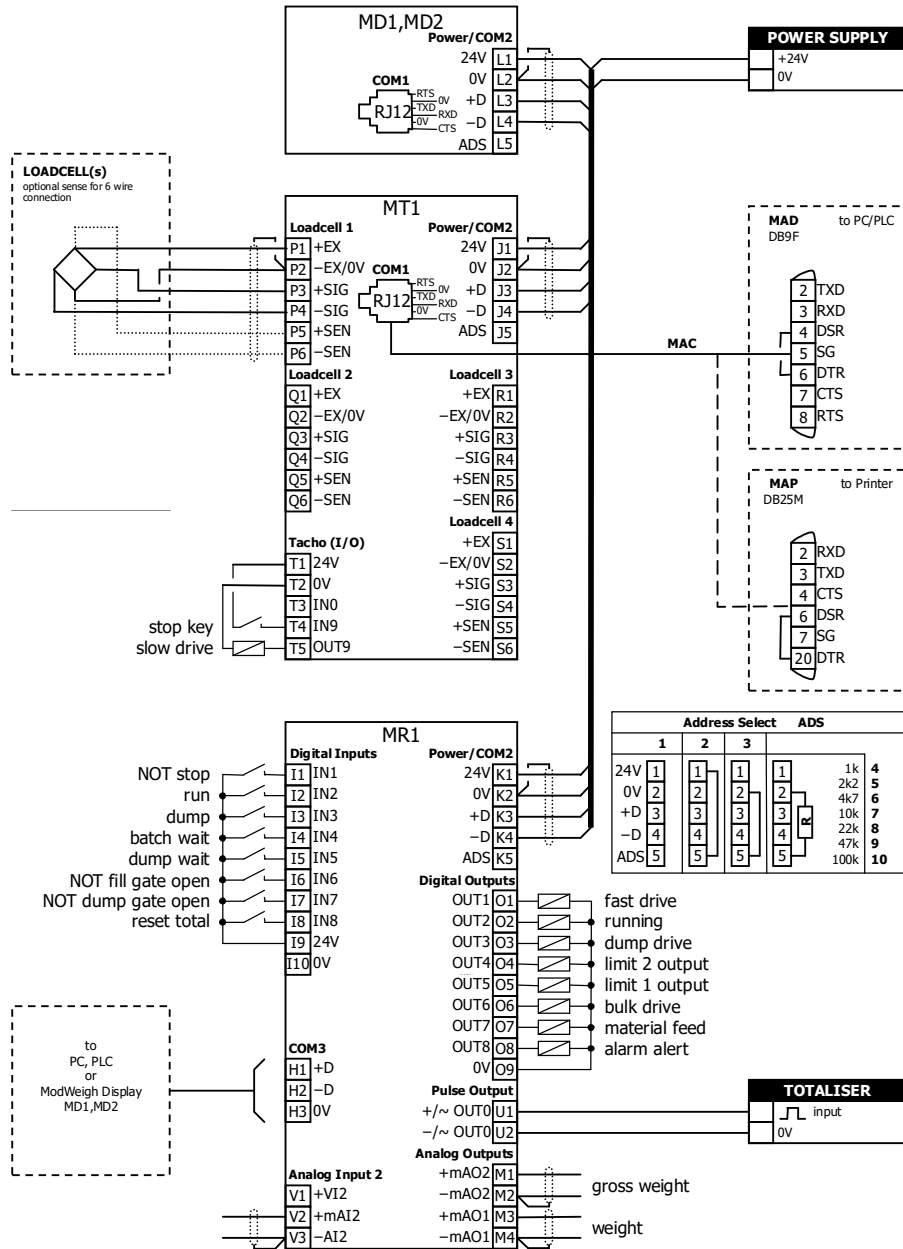

Connection Diagram – MT3

Keep all wiring separated from mains wiring.

Use shielded cable where indicated.

Display and transmitter can alternatively be connected COM1 to COM1 using an MAC cable.

MT3 bus address set with ADS pin or a setting.

MR1 bus address set with ADS pin and must be same as MT3.

Fit an MAT terminator to each end of COM2 cable if length exceeds 50m.

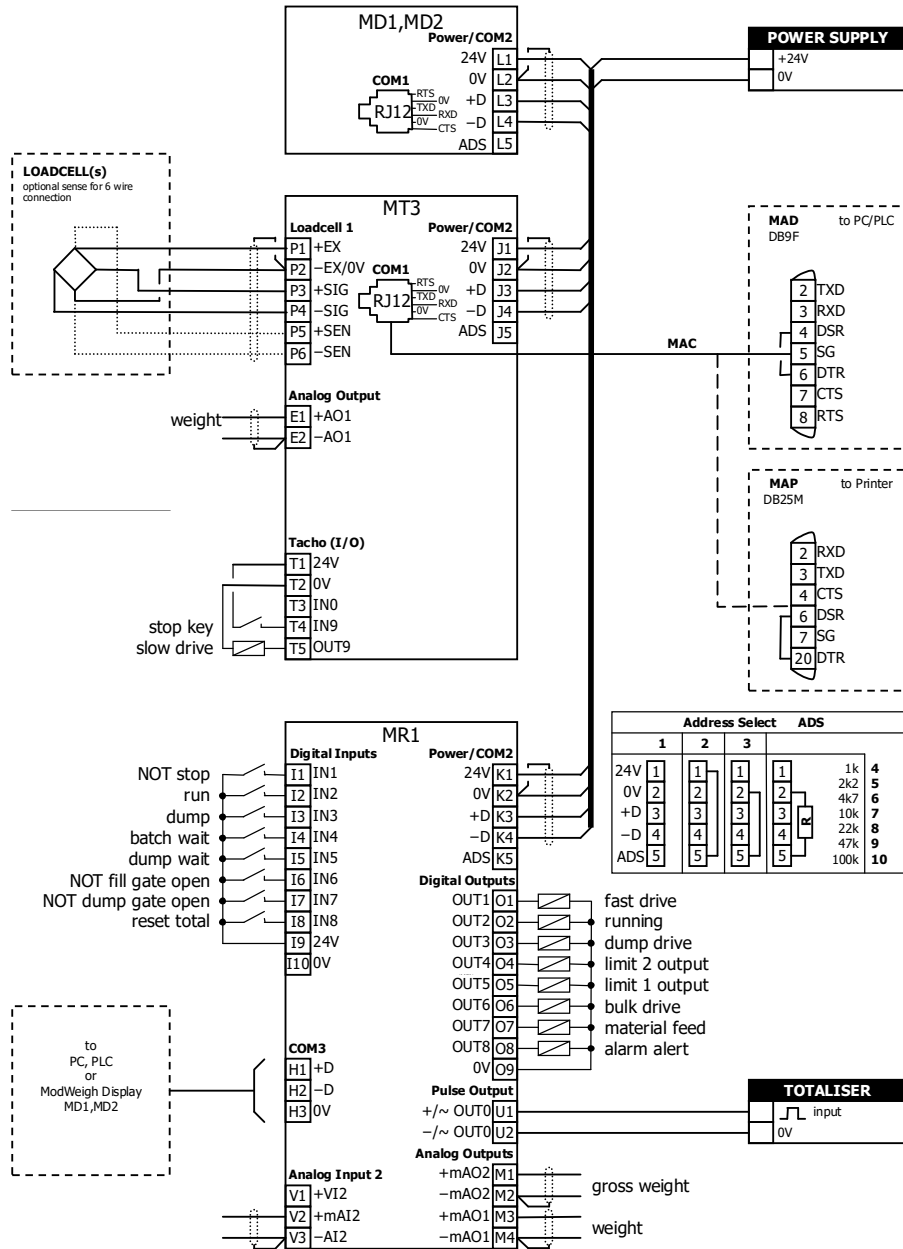

Applications

Following are typical applications for the instrument.

Process Weigher

Used to measure and/or control the flow of material through a weigh hopper.

A fill gate controls material flow into a weigh hopper. The hopper is filled to a preset weight and then the material discharged by opening the dump gate. The weight of material discharged is accumulated to measure the throughput and if required control the throughput.

Optional reed switches on each gate can inform the controller that the gates are closed and are used to detect hardware failures.

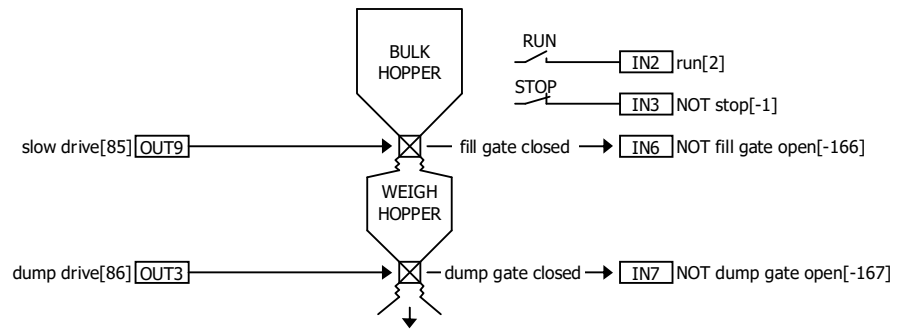

Quick Key	Description	Setting	Details
Q23211	batch setpoint	kg	set to desired batch weight
Q23216	number to batch		sets the number of batches to run before stopping
Q23721	set local flowrate	t/h	sets the flowrate required
Q23232	gate drive stop option		can be set to open both gates when the process weigher has stopped
Q23241	low weight	kg	dump end weight
Q23242	high weight	kg	sets the weight of each individual batch







The 'batch setpoint' sets how much material to run through the process weigher after it has been started. When this weight is reached, the process weigher stops.

If the 'number to batch' has been set, the process weigher stops after the number of batches has run.

If 'set local flowrate' has been set, the weigh hopper discharge will be delayed so that the flowrate passing through the process weigher is the set value.

System Ordering

A ModWeigh system is a group of ModWeigh parts that together form the system. Many possible systems can be created, but most applications will use one of the systems listed below. When ordering, just specify the system order code. To create a custom system, specify the individual components required.

Process Weigher	System Order Code
Product Key, Processor, IO 	MK65A,MP2,MR3
Product Key, Processor, IO 	MK65A,MP1,MR1
Transmitter, display, IO 	MW65A,MT3,MD1,MR1
Transmitter, display, IO 	MW65A,MT3,MD2,MR1
P-Module, transmitter, display, IO 	MW65A,MT1,MD1,MR1
P-Module, transmitter, display, IO 	MW65A,MT1,MD2,MR1

Parts Ordering

Following is a list of order codes for the individual parts of a ModWeigh system.

The order code (and options) are shown below.

Product

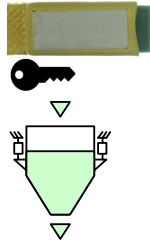

select one of the following	
P-Module (for transmitter only)	MW65A
Unactivated P-Module (requires a product key)	MX65A
Product Key	MK65A

Special Options



select any (or none) of the following	
Chinese manuals	,CH
Korean manuals	,KO
German manuals	,DE
Spanish manuals	,ES
French manuals	,FR
Italian manuals	,IT
Polish manuals	,PL
No manuals	,NM
Manufacturing certificate	,MC

Processor



select one (or none) of the following	
Loadcell processor	,MP2
Loadcell processor	,MP1
Loadcell transmitter	,MT3
Loadcell transmitter	,MT1

Transmitter



IO Option



select one (or none) of the following (only for MP2)	
digital IO - 4In 4Out, 1 x 4-20mA input & output	,MO3

Display



select one (or none) of the following	
4.3" Colour display	,MD1
2.8" Colour display	,MD2

Remote IO



select one (or none) of the following	
Remote IO unit	,MR1

Accessories



select one (or none) of the following	
RJ12 Cable 2m (COM1 cable)	,MAC
RJ12 to 9 pin D-connector adaptor (ModWeigh to PC)	,MAD
RJ12 to 25 pin D-connector adaptor (ModWeigh to printer)	,MAP
DIN Rail mount kit for MT1,MT3 or MR1	,MAR
Stack mount kit for MT1,MT3 or MR1	,MAS
RS485 Line Terminator	,MAT

Other ModWeigh Products

Contact Details

WESTERN AUSTRALIA

22 Beneficial Way,
Wangara, WA 6065
+61 8 6314 1111
support@automation-control.com.au
ABN: 87 619 578 595

NEW SOUTH WALES

Unit 7, 70 Holbeche Road,
Arndell Park, NSW 2148
+61 2 8078 2288
support@automation-control.com.au
ABN: 61 645 267 116

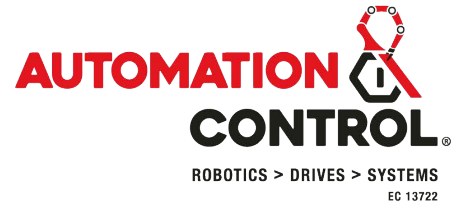

automation-control.com.au



As we are continuously improving our products, changes to this specification may occur without notice.

(Document Details: g0 g1 g2 g3 g4 g5 g6 g7 g8 g9 g10 g11 g12 g13 g14 g15 MT1,MT3,MD1,MD2,MP1,MP2))