

SMART MANUFACTURING

We Provide Affordable, Accessible, Innovative and Secure Intelligent, Seamless and Collaborative Networked-Based Solutions

- ⚙ Manufacturing Productivity Analysis
- ⚙ Automation Design & Proposal
- ⚙ Project Management

SOLUTION FOR EVERY
Phase Of Your Production Line



MODU Technologies sdn bhd
 (MTEch) is incorporated in 2015.
 We are a renowned one stop turnkey material handling and factory automation solution provider in Malaysia. MTEch is an offshoot company of MODU System (M) Sdn. Bhd., a company well known for its conveyor system since 1995. MODU range of conveyors system are widely used in many global manufacturers in the food, pharmaceuticals, personal care as well as in electricals & electronics industry.



M Modular Plastic Chain & Plastic Belt Conveyor

PLASTIC CHAIN

Aluminium Frame	M52	MM3	M52	MX2
Stainless Steel Frame	DS2	DM3	DL2	DX2
Chain width	63 mm	83 mm	140 mm	220 mm
Beam width	65 mm	85 mm	145 mm	225 mm

PLASTIC BELT

Aluminium Frame	MT2	MR2	MF2
Stainless Steel Frame	DT2	DR2	DF2
Chain width	315 mm	438 mm	585 mm
Beam width	360 mm	480 mm	625 mm

Palletizing System

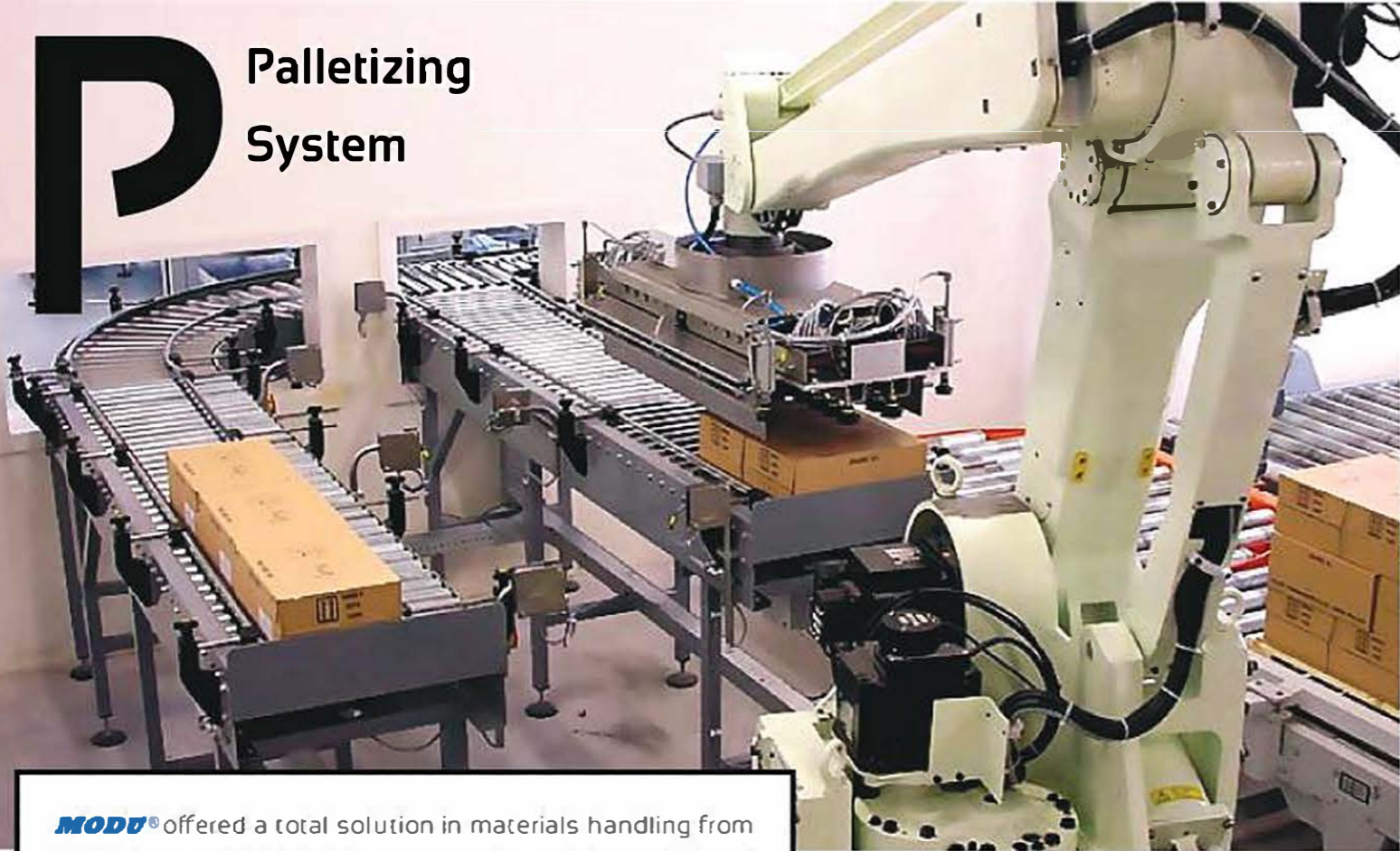

MODU® offered a total solution in materials handling from productions to finish goods. Solutions comprising a mixture of conveyor system and industrial robot ensures efficiency and efficacy in a manufacturing plant.

Product palletizing using an industrial robot is very popular in modern packaging line nowadays as it minimised manpower as well as industrial mishaps, ensuring high productivity.

MTech works with the major robotic suppliers to ensure that every production specification requirements are met. All **MODU**® solutions are carefully customised according to your needs.



Begin designing your custom made solution

S Spiral Conveyor

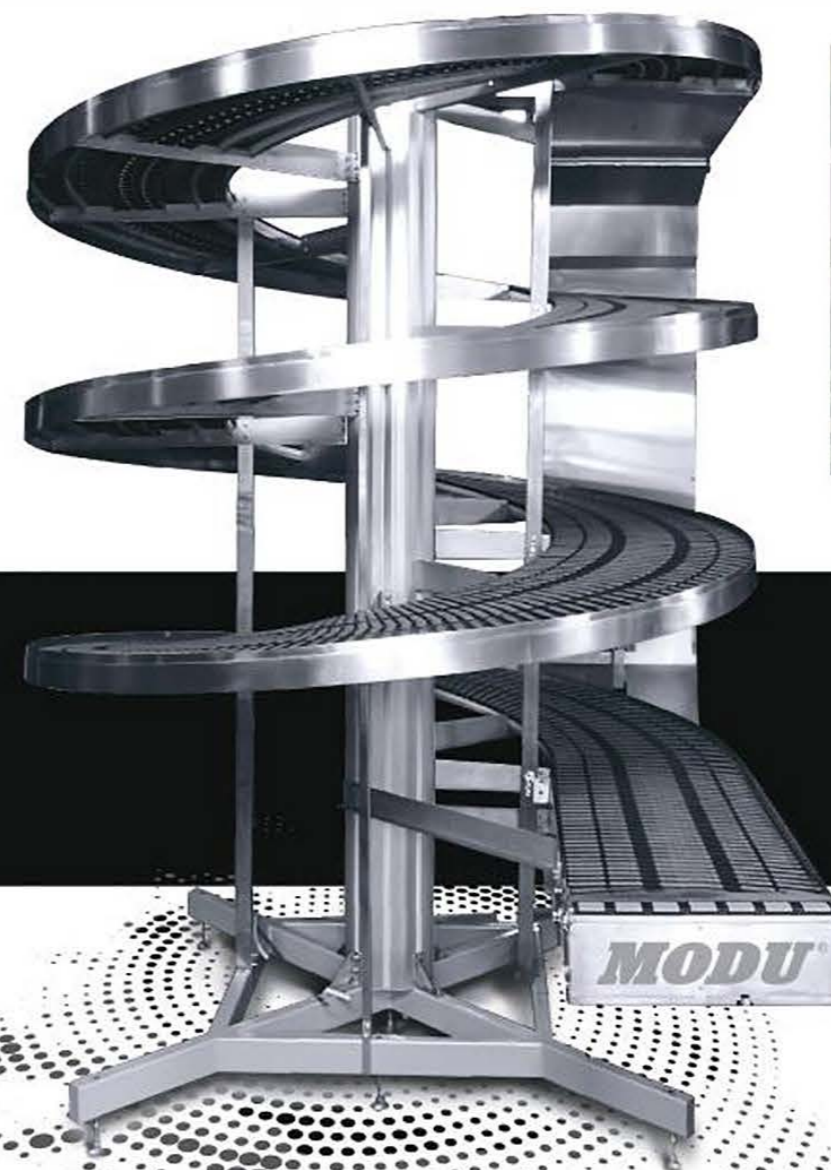

INNOVATIVE DESIGN

MODU® Spirals conveyors are designed to be reliable, flexible and easy to operate. **MODU**® Automatic Lubrication System (ALS) and Chain Tension Adjustment System makes the spiral conveyor easy to maintain.

Conveyor chain can be easily tensioned with the needs of special tools.

A Automated Guided Vehicle

Customizable . Smart . Durable

MODU® Automated Guided Vehicle (AGV) is a mobile robot that can automatically navigate and transport materials from one location to another. It is suitable for (not limited to) manufacturing, textile, automotive, food & beverage, warehousing, hospital operations, etc.

R Robotic Automation



MODU® AGV is a modern AGV equipped with the latest technologies. Its modular design is flexible and easy to maintain. Powered by NavWiz system, the usage and programming of an AGV has never been this easy and simple.

⚙️ Features

- Modular
- Safety
- Sixteen I/O
- NavWiz Task
- Auto Charging
- Bi-Directional
- Differential Driven
- Internet of Thing



Cabinet



Hooking



Towing



Articulated Robot

Product Range

Improving productivity, quality and workplace safety

MTech is a channel partner with renowned Industrial robot maker ABB Robots. Together we have rolled out many robotic applications across all industries in Malaysia.

High Speed
High efficiency
High Productivity



Delta robot with assembly line ▶



Scara Robot



Collaborative Robot

T

Twin Track Assembly Line

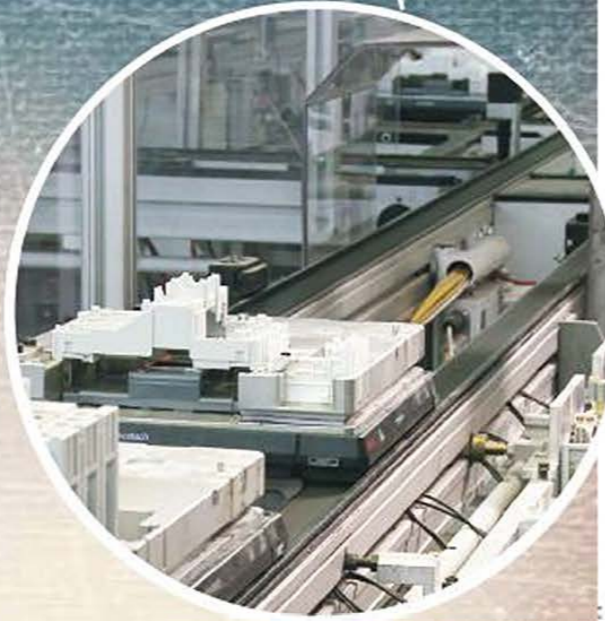
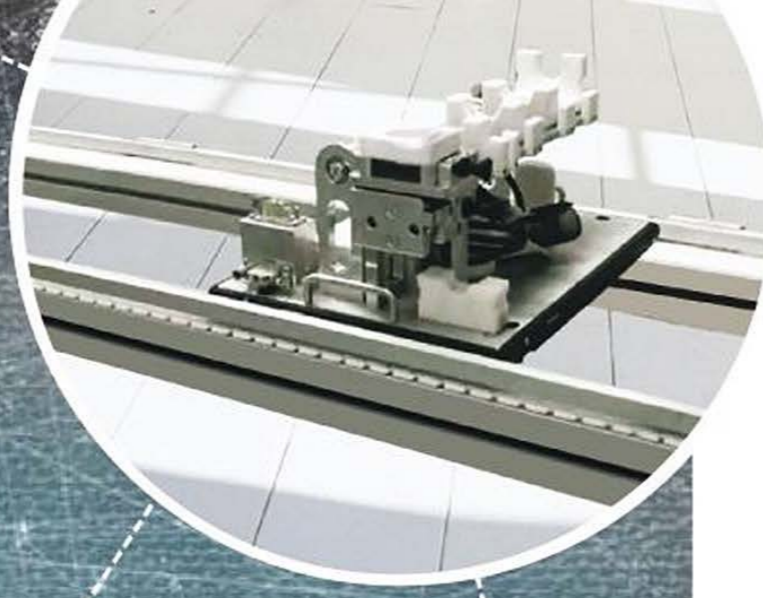

Assembly line configurations could be changed easily according to new needs and processes.

Twin track pallets assembly solutions were designed to convey pallets/slave board from one process or assembly station to another. Based on a modular system, these solutions offered customers plug and play solutions with flexible configurable options.

MODU® assembly solutions also include RFID SCADA & MES solutions integration for traceability and seamless production process.

C

Customised Automation System



MTech offered highly customised automation system to our customer. As a turnkey materials handling solutions provider, MTech also offers customised solutions to each process so all processes could be streamlined into the whole production floor efficiently, without the needs to refer to a multi-party set up.



Elevator G

Gripper System

continuous elevator/lowerator



Convey bagged products

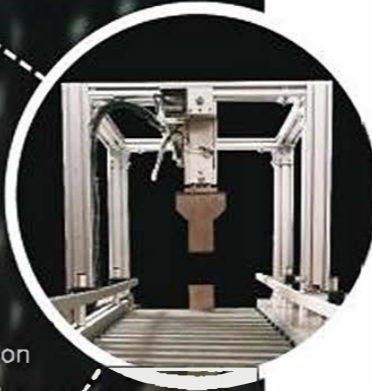

- Quick access maintenance touch panel
- Comprehensive guiding
- Continuous flow elevating with no reciprocating action
- Universal mounts for any type of infeed and outfeed conveyor
- Available in multiple heights, capacities and payload sizes
- Available in both Aluminium and Stainless-Steel frame
- Space Saving

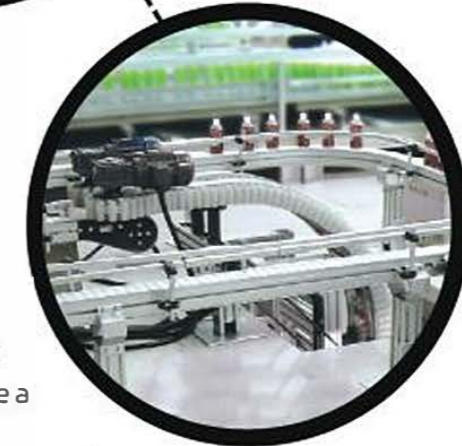
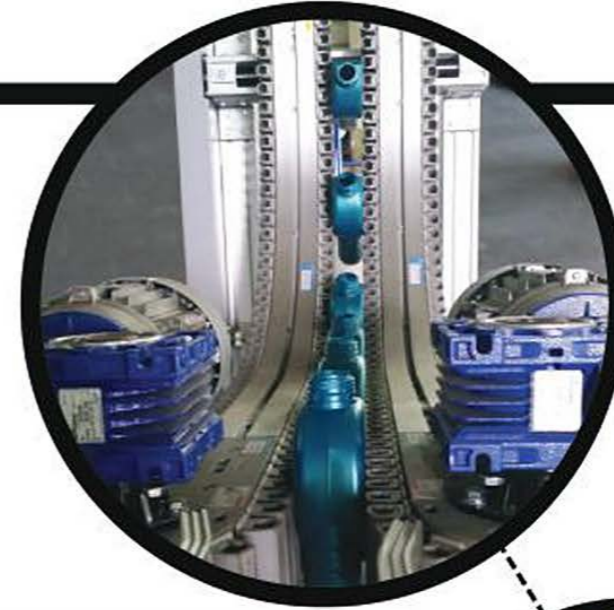
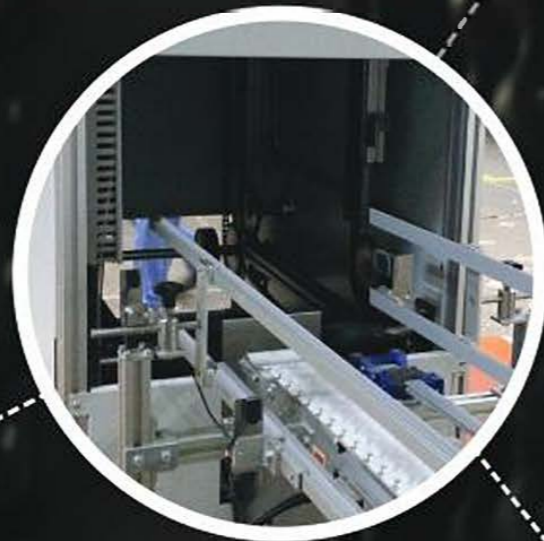

Gripper System Elevator / Lowerator

Gripper conveyor was a conveyor system which utilised 2 sets of conveyors set up in a gripping format, to move a product from a lower elevation to upper elevation or vice versa, only taking up very minimum floor space. Gripper conveyors are ideal set up for high speed production or packaging line.

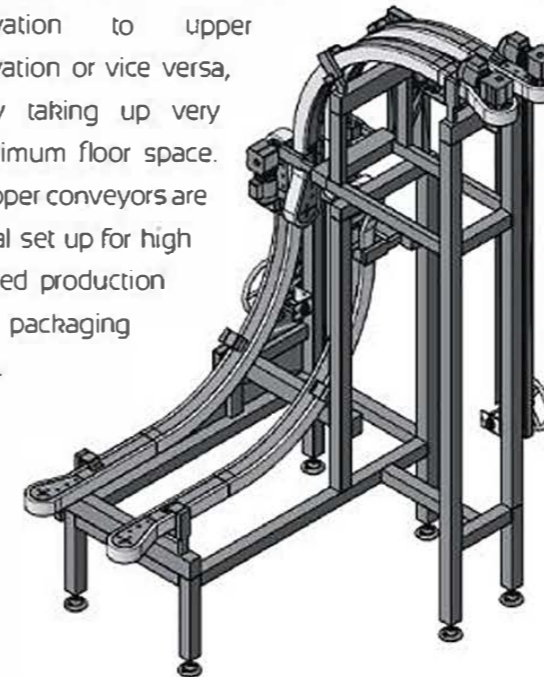

4.0

Industry 4.0 Solution

All **MODU**® solutions are Industry 4.0 ready, making MTech your ideal partner in Smart Automation.



TURNKEY SOLUTION

We provide a total turnkey solution for your manufacturing processes needs. With our vast skills and expertise, along with our reliable sales and services networks, we are confident in providing our solutions for every stage of the manufacturing line.

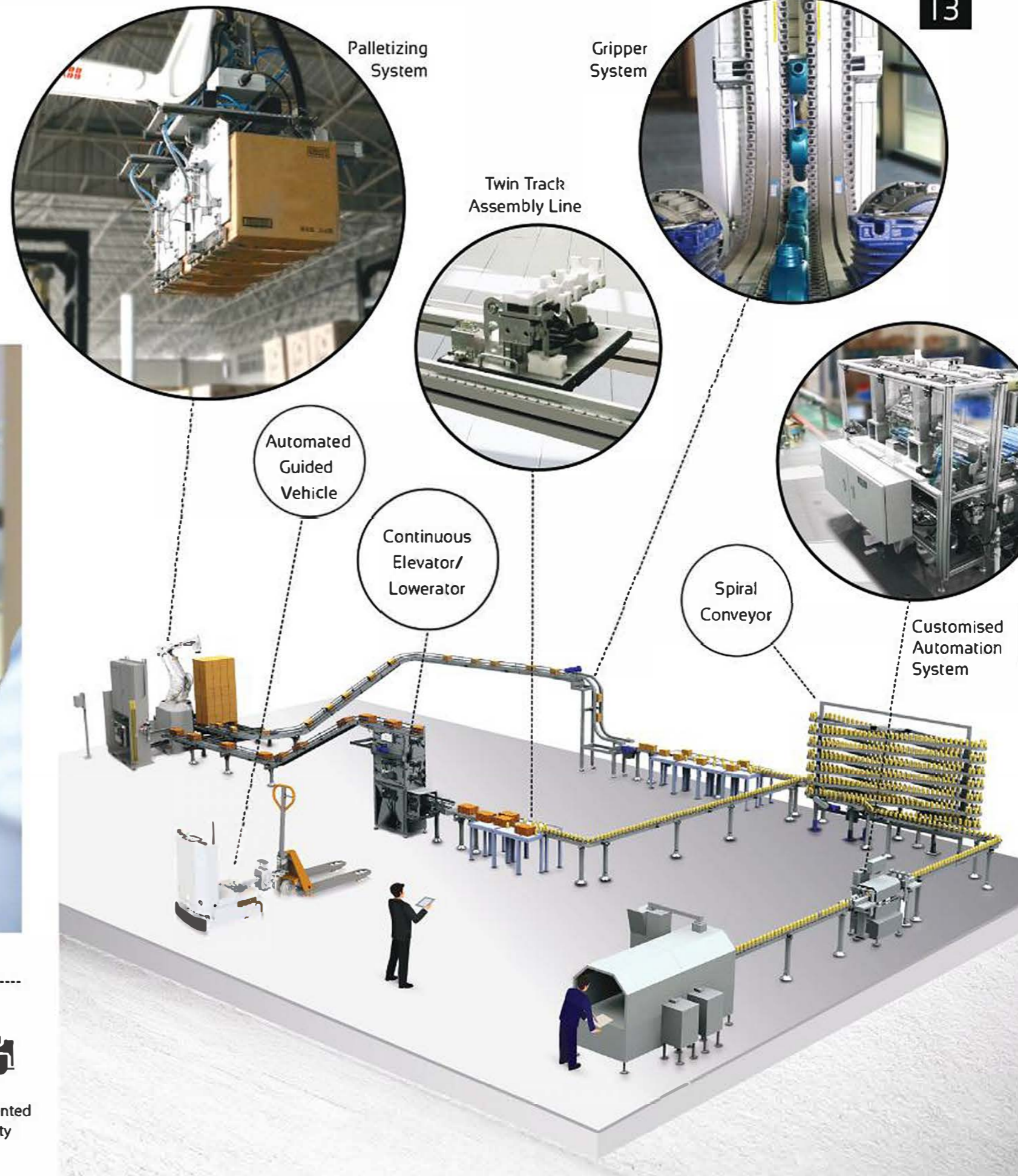

----- 3rd platform, innovation accelerators, OT and manufacturing meet in transformation -----

- Autonomous Robots
- System Integration
- Cloud Computing
- Internet Of Things
- Cybersecurity
- Big data
- Additive Manufacturing
- Simulation
- Augmented Reality

Industries

FLEXIBLE RELIABLE



MODU have made significant progress in the conveyor business surging ahead of its competitors, to provide a 'one-stop modular conveyor and automation system centre' to serve a variety of industries. This is further accentuated by a proven track record in the international business arena and a widespread acceptance and recognition of its largely superior products, innovative designs and professional services.



Flexible & Reliable Solutions For Increased Productivity

At **MODU**, we understand our customers' needs. We are committed to deliver high quality and reliable, yet cost effective, solutions. We worked closely with our customers to ensure systems and solutions we supplied will fulfil the ever-changing demands and needs of the market.

Food & Packaging



Paper Converting



Personal Products & Pharmaceutical



Home Appliances Assembly



Electronic & Electrical

Our customer base includes many of the world's leading companies

