

Torsional Highflex Couplings

RINGFEDER® TNR 2424.1

Single-row, SAE flange-shaft connections

DISTRIBUTED BY



chainanddrives.com.au
support@chainanddrives.com.au

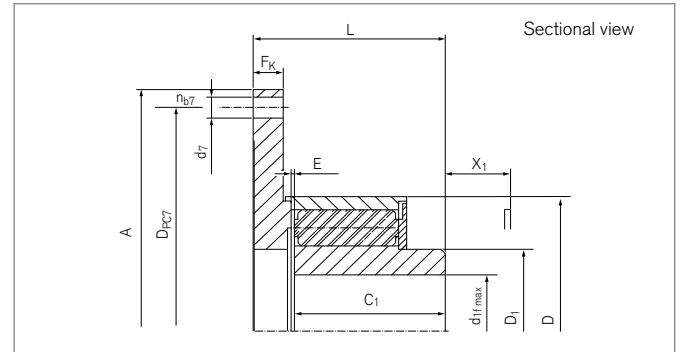
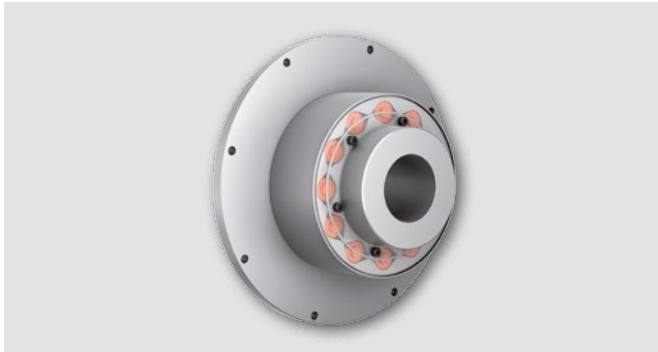

Size	$d_{1f\ max}$	SAE size	A	D_{PC7}	d_7	n_{b7}	D	D_1	C_1
			mm	mm	mm		mm	mm	mm
120.1 - 06.5	50	6,5	215,9	200,0	9,5	6	120	73	65
120.1 - 07.5	50	7,5	241,3	222,3	9,5	8	120	73	65
120.1 - 08.0	50	8,0	263,5	244,5	11,0	6	120	73	65
120.1 - 10.0	50	10,0	314,3	295,3	11,0	8	120	73	65
160.1 - 06.5	70	6,5	215,9	200,0	9,5	6	160	100	90
160.1 - 07.5	70	7,5	241,3	222,3	9,5	8	160	100	90
160.1 - 08.0	70	8,0	263,5	244,5	11,0	6	160	100	90
160.1 - 10.0	70	10,0	314,3	295,3	11,0	8	160	100	90
200.1 - 07.5	90	7,5	241,3	222,3	9,5	8	200	129	115
200.1 - 08.0	90	8,0	263,5	244,5	11,0	6	200	129	115
200.1 - 10.0	90	10,0	314,3	295,3	11,0	8	200	129	115
200.1 - 11.5	90	11,5	352,4	333,7	11,0	8	200	129	115
260.1 - 10.0	115	10,0	314,3	295,3	11,0	8	260	165	140
260.1 - 11.5	115	11,5	352,4	333,7	11,0	8	260	165	140
260.1 - 14.0	115	14,0	466,7	438,2	14,5	8	260	165	140
260.1 - 16.0	115	16,0	517,5	489,0	14,5	8	260	165	140
320.1 - 14.0	145	14,0	466,7	438,2	14,5	8	320	210	175
320.1 - 16.0	145	16,0	517,5	489,0	14,5	8	320	210	175
320.1 - 18.0	145	18,0	571,5	542,9	18,0	6	320	210	175
400.1 - 16.0	185	16,0	517,5	489,0	14,5	8	400	275	230
400.1 - 18.0	185	18,0	571,5	542,9	18,0	6	400	275	230
400.1 - 21.0	185	21,0	673,1	641,4	18,0	12	400	275	230
400.1 - 24.0	185	24,0	733,4	692,2	22,0	12	400	275	230
500.1 - 21.0	230	21,0	673,1	641,4	18,0	12	500	335	300
500.1 - 24.0	230	24,0	733,4	692,2	22,0	12	500	335	300

To continue see next page

Torsional Highflex Couplings RINGFEDER® TNR 2424.1

Size	L	E	F _E	F _K	X ₁	J _F	J _N ¹⁾	Gw _{ub} ¹⁾
	mm	mm	mm	mm	mm	10 ⁻³ kgm ²	10 ⁻³ kgm ²	kg
120.1 - 06.5	84	4,0	+/-1,0	13	28	6	2	4,1
120.1 - 07.5	84	4,0	+/-1,0	13	28	9	2	4,4
120.1 - 08.0	84	4,0	+/-1,0	13	28	12	2	4,7
120.1 - 10.0	84	4,0	+/-1,0	13	28	26	2	5,4
160.1 - 06.5	111	4,0	+/-1,0	15	23	9	11	8,6
160.1 - 07.5	111	4,0	+/-1,0	15	23	12	11	8,9
160.1 - 08.0	111	4,0	+/-1,0	15	23	16	11	9,2
160.1 - 10.0	111	4,0	+/-1,0	15	23	31	11	10,1
200.1 - 07.5	140	5,0	+/-1,5	18	28	23	35	16,9
200.1 - 08.0	140	5,0	+/-1,5	18	28	28	35	17,3
200.1 - 10.0	140	5,0	+/-1,5	18	28	45	35	18,4
200.1 - 11.5	140	5,0	+/-1,5	18	28	66	35	19,3
260.1 - 10.0	172	6,0	+/-1,5	24	40	92	116	35,0
260.1 - 11.5	172	6,0	+/-1,5	24	40	118	116	36,3
260.1 - 14.0	172	6,0	+/-1,5	24	40	260	116	40,4
260.1 - 16.0	172	6,0	+/-1,5	24	40	381	116	42,8
320.1 - 14.0	212	7,0	+/-2,0	26	45	474	375	73,5
320.1 - 16.0	212	7,0	+/-2,0	26	45	662	375	76,6
320.1 - 18.0	212	7,0	+/-2,0	26	45	1195	375	83,0
400.1 - 16.0	271	8,0	+/-2,0	31	46	760	1274	142,0
400.1 - 18.0	271	8,0	+/-2,0	31	46	971	1274	146,0
400.1 - 21.0	271	8,0	+/-2,0	31	46	1579	1274	153,0
400.1 - 24.0	271	8,0	+/-2,0	31	46	2035	1274	158,0
500.1 - 21.0	346	10,0	+/-2,5	34	52	2402	4155	289,0
500.1 - 24.0	346	10,0	+/-2,5	34	52	2877	4155	294,0

¹⁾ Weight and moment of inertia for unbored hubs

To continue see next page

Torsional Highflex Couplings RINGFEDER® TNR 2424.1

Explanations

d_{1f max} = Max. bore diameter d ₁ with keyway acc. to ANSI B17.1	D = Outer diameter	F_K = Flange thickness
SAE = Flange connection to SAE J 620 d	D₁ = Outer diameter	X₁ = Required space for dismounting of the elastic buffer
A = Max. outer diameter	C₁ = Guided length in hub bore	J_F = Moment of inertia on thrust flange side
D_{PC7} = Pitch circle diameter of bore holes d ₇	L = Total length	J_N = Moment of inertia hub side
d₇ = Bore diameter	E = Gap width between left and right component	G_{wub} = Weight, unbored
n_{b7} = Quantity of bore d ₇	F_E = Tolerance of the gap width E	

Ordering example

Series	Size	Buffer	d _{1f}	Further details ^{*)}
TNR 2424.1	200.1 - 08.0	Pb 70	80	*

^{*)} Without any other specification, we deliver as a standard: with set screws and keyway acc. to DIN 6885-1, keyway side fit P9, bore tolerance H7

Further information on
RINGFEDER® TNR 2424.1

DISTRIBUTED BY



chainanddrives.com.au
support@chainanddrives.com.au

Disclaimer of liability

All technical details and notes are non-binding and cannot be used as a basis for legal claims. The user is obligated to determine whether the represented products meet his requirements. We reserve the right carry out modifications at any time in the interests of technical progress.