

Torsional Highflex Couplings

RINGFEDER® TNR 2428.2

Two-row, shaft-shaft connections

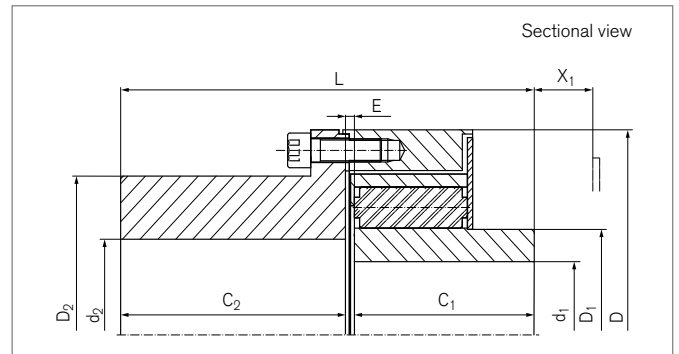

Size	$d_{1f \max}$	$d_{2f \max}$	D	D_1	D_2	C_1	C_2
	mm	mm	mm	mm	mm	mm	mm
160.2	50	75	160	73	115	65	90
200.2	70	105	200	100	155	90	115
260.2	90	130	260	129	195	115	140
320.2	115	165	320	165	245	140	175
400.2	145	215	400	210	305	175	230
500.2	185	250	500	275	350	230	300
640.2	230	320	640	335	450	300	380

Size	L	E	F_E	X_1	J_F	$J_N^{1)}$	$G_{W_{ub}}^{1)}$
	mm	mm	mm	mm	10^{-3}kgm^2	10^{-3}kgm^2	kg
160.2	159	4	-1,0	28	23	3	12,8
200.2	210	5	-1,5	23	81	14	28,1
260.2	261	6	-1,5	28	268	44	56,6
320.2	322	7	-2,0	40	794	144	110,0
400.2	413	8	-2,0	50	2363	462	219,0
500.2	540	10	-2,5	52	6100	1544	409,0
640.2	695	15	-4,5	60	21052	5100	855,0

¹⁾ Weight and moment of inertia for unbored hubs

To continue see next page

Torsional Highflex Couplings RINGFEDER® TNR 2428.2

Explanations

d_{1f max} = Max. bore diameter d ₁ with keyway acc. to ANSI B17.1	D₂ = Outer diameter hub	F_E = Tolerance of the gap width E
d_{2f max} = Max. bore diameter d ₂ with keyway acc. to ANSI B17.1	C₁ = Guided length in hub bore	X₁ = Required space for dismounting of the elastic buffer
D = Outer diameter	C₂ = Guided length in hub bore	J_F = Moment of inertia on thrust flange side
D₁ = Outer diameter	L = Total length	J_N = Moment of inertia hub side
	E = Gap width between left and right component	G_{wub} = Weight, unbored

Ordering example

Series	Size	Buffer	d _{1f}	d _{2f}	Further details*)
TNR 2428.2	260.2	Vk 90/Vk 80	80	120	*

*) Without any other specification, we deliver as a standard: with set screws and keyway acc. to DIN 6885-1, keyway side fit P9, bore tolerance H7

Further information on
[RINGFEDER® TNR 2428.2](#)

DISTRIBUTED BY



chainanddrives.com.au
 support@chainanddrives.com.au

Disclaimer of liability

All technical details and notes are non-binding and cannot be used as a basis for legal claims. The user is obligated to determine whether the represented products meet his requirements. We reserve the right carry out modifications at any time in the interests of technical progress.