

Steel Disc Couplings

RINGFEDER® TND VDV

Inverted Hubs, Double-Jointed, with Spacer,
Shaft-Hub Connection by Keyway

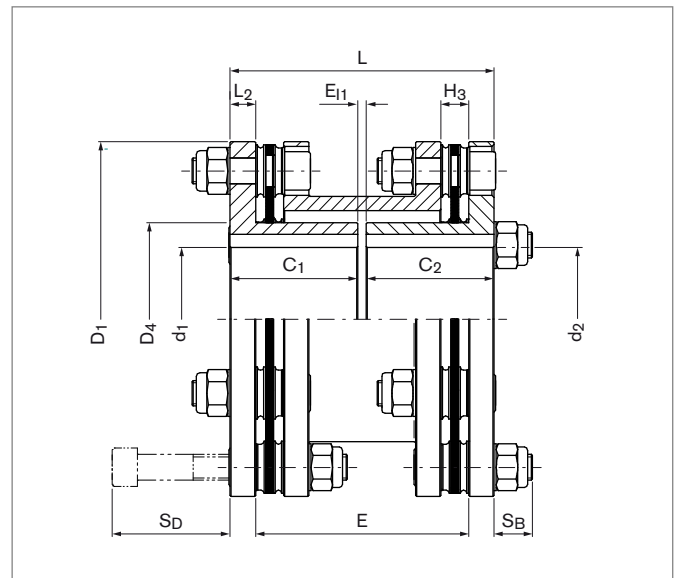
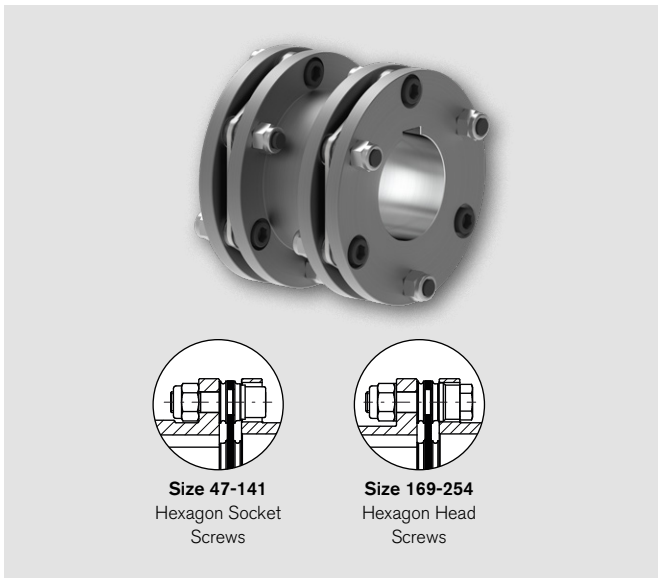

Size	$T_{KNHD}^{1)}$	$T_{KNHT}^{1)}$	$n_{max}^{2)}$	$d_{pre}^{3)}$	$d_{1k}; d_{2k}^{4)}$	C_1 / C_2	E_{11}	$E^{5)}$	H_3	D_1	D_4	L_2	L	S_B	S_D	n_{Sc}
VDV	Nm	Nm	1/min	mm	mm	mm	mm	mm	mm	mm	mm	mm	mm	mm	mm	Quantity
47	170	230	12200	10	25	33 39,5	4 31	60 100	7,5	70,5	37	5	70 110	7	24	6
63	320	420	9900	14	32	41 45	4 6	70 80	9	88	48	8	86 96	9	32	6
82	750	1050	7500	15	44	55 55	10 50	100 140	10,5	116	64	10	120 160	11	40	6
98	1350	1750	6200	19	50	59 60	4 42	100 140	12	140,5	77	11	122 162	15	47	6
118	2400	3000	5250	25	60	60 75	4 14	100 140	13	166,5	90,5	12	124 164	17	55	6
141	4000	5200	4400	30	75	81 90	6 28	140 180	15	198,5	114	14	168 208	18	64	6
169	6500	8500	3650	39	90	103 125	6 32	180 250	21	238	135	16	212 282	24	81	6
205	21000	26000	2950	59	115	142	10	250	28	295	170	22	294	27	112	8
254	36000	44000	2500	79	120	146 171	10 10	250 300	32,5	345	180	26	302 352	29	133	8

To continue see next page

Steel Disc Couplings RINGFEDER® TND VDV

Size	E ⁵⁾	G _{WSB} ⁶⁾	J _{SB} ⁶⁾	C _{Tdyn} HD	C _{Tdyn} HT	Max. Permissible Misalignment ⁷⁾					
						axial		angular		radial	
VDV	mm	kg	10 ⁻³ kgm ²	10 ⁶ Nm/rad	10 ⁶ Nm/rad	ΔK _s HD	ΔK _s HT	ΔK _w HD	ΔK _w HT	ΔK _r HD	ΔK _r HT
						mm	mm	Degrees	Degrees	mm	mm
47	60	1,2	0,6	0,071	0,075	1	0,6	2	1,4	0,8	0,6
	100	1,4	0,66	0,059	0,062					1,5	1,1
63	70	2,4	2,04	0,126	0,139	1	0,8	2	1,4	1	0,7
	80	2,5	2,08	0,126	0,139					1,1	0,8
82	100	5,7	7,90	0,271	0,308	1,4	0,8	2	1,4	1,4	1,1
	140	6	8,32	0,246	0,277					2,1	1,5
98	100	8,8	18,36	0,513	0,543	2	1,2	2	1,4	1,5	1
	140	9,2	19,22	0,469	0,494					2,1	1,5
118	100	13,1	39,38	0,914	0,948	2,4	1,6	2	1,4	1,4	1
	140	13,8	41,44	0,855	0,884					2,1	1,5
141	140	22,6	100,41	1,306	1,362	2,8	1,6	2	1,4	2	1,5
	180	24,7	105,33	1,229	1,279					2,7	2
169	180	43,5	256,20	2,375	2,898	3	2,4	2	1,4	2,6	1,9
	250	46,2	273,61	2,231	2,686					3,8	2,7
205	250	93,4	862,77	8,265	8,389	2,2	1,2	1	0,8	1,8	1,5
254	250	132,8	1734,93	14,302	14,497	2,2	1,6	1	0,8	1,8	1,5
	300	136,6	1774,98	13,163	13,328					2,2	1,8

- 1) When selecting the size, it is essential to observe the instructions on coupling dimensioning in the document "Product Paper & Tech Paper RINGFEDER® Steel Disc Couplings". Short-term peak torque T_{kmax} is limited to 1.75 multiples of T_{KN}.
- 2) For longer spacers, check bending critical rotational speed.
- 3) Pre-bore has free tolerance.
- 4) Maximum finished bore with keyways according to DIN 6885-1.

- 5) Longer spacers on request.
- 6) Weight and mass moments of inertia for pre-bored hubs.
- 7) The maximum misalignment values must not apply simultaneously. The instructions on coupling dimensioning in the document "Product Paper & Tech Paper RINGFEDER® Steel Disc Couplings" are to be observed.

To continue see next page

Steel Disc Couplings RINGFEDER® TND VDV

Explanations

T_{KNHD} = Nom. transmissible torque with disc pack HD	H₃ = Width of the disc pack	C_{TdynHT} = Dynamic torsional stiffness with disc pack HT
T_{KNHT} = Nom. transmissible torque with disc pack HT	D₁ = Max. outer diameter	ΔK_{aHD} = Max. permissible axial misalignment with disc pack HD
n_{max} = Max. rotational speed	D₄ = Outer diameter of the inverted hub	ΔK_{aHT} = Max. permissible axial misalignment with disc pack HT
d_{pre} = Diameter pre-bore	L₂ = Hub flange thickness	ΔK_{wHD} = Max. permissible angular misalignment with disc pack HD
d_{1kmax} = Max. bore diameter d ₁ with keyway acc. to DIN 6885-1	L = Total length	ΔK_{wHT} = Max. permissible angular misalignment with disc pack HT
d_{2kmax} = Max. bore diameter d ₂ with keyway acc. to DIN 6885-1	S_B = Protruding of the screw	ΔK_{rHD} = Max. permissible radial misalignment with disc pack HD
C₁ = Guided length in hub bore	S_D = Disassembly space	ΔK_{rHT} = Max. permissible radial misalignment with disc pack HT
C₂ = Guided length in hub bore	n_{sc} = Quantity of screws	
E₁₁ = Distance between hubs	G_{WSB} = Weight at smallest bore diameter	
E = Distance between hubs	J_{SB} = Moment of inertia at smallest bore diameter	
	C_{TdynHD} = Dynamic torsional stiffness with disc pack HD	

Ordering example

Type	Size	Disc pack	Distance between hubs E	Bore diameter d ₁	Bore diameter d ₂
TND VDV	118	HD	140	60	60

Further information on
RINGFEDER® TND VDV

Technical Information

- Without further specifications, we deliver as standard: Bore tolerance H7; Keyway acc. to DIN 6885-1; Keyway width tolerance P9.
- From a peripheral speed of 30 m/s, separate balancing of the individual coupling parts is recommended.
- Without further instructions on balancing, the coupling parts are balanced individually according to DIN 21940-11 in quality G 6,3 at 1,500 1/min. The hubs are balanced half key (before grooving), the spacer without screwed-on disc packs.

DISTRIBUTED BY



chainanddrives.com.au
support@chainanddrives.com.au

Disclaimer of liability

All technical details and notes are non-binding and cannot be used as a basis for legal claims. The user is obligated to determine whether the represented products meet his requirements. We reserve the right to carry out modifications at any time in the interests of technical progress.