

CHAIN & DRIVES.

chainanddrives.com.au
support@chainanddrives.com.au

CONVEYOR BELT



BANDO

Breakthroughs for the future

C-CJ-003-002

2017- 4

CONTENTS

Eco Carry
Page 2 ~ 3

Heat Carry Selection
Page 4 ~ 5

Heat & Fire Resistant Conveyor Belt
Page 6 ~ 7

Gypsum Board Conveyor Belt
Page 8 ~ 9

Power Ace Aramid Combo
Page 10 ~ 11

Flexowell Conveyor Belt
Page 12 ~ 13

Pipe Conveyor Belt
Page 14 ~ 15

Steel Cord Conveyor Belt
Page 16 ~ 17

Rock Belt
Page 18 ~ 19

Rip Detector type-7
Page 20 ~ 21

Sunpat Eco
Page 22

Service for the Market
Page 23 ~ 24

Quality Assurance
Page 25

Required Application Form
Page 26



Breakthroughs for the future



Eco Carry

environmentally-friendly

Bando Eco Carry **Energy saving !! Tension can be reduced**

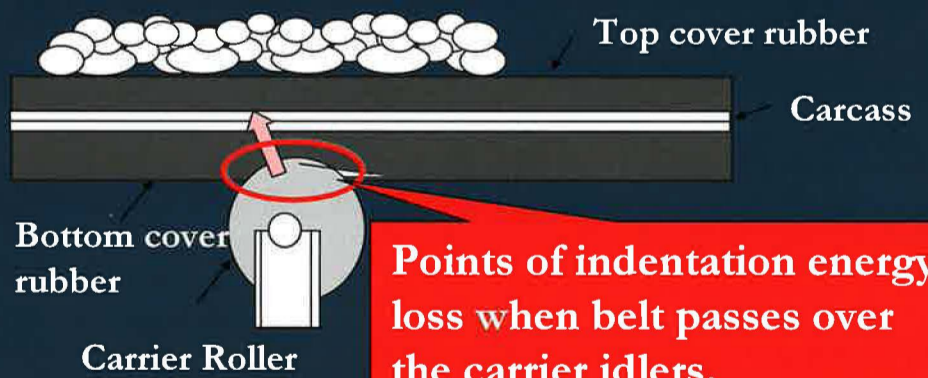

Bando has developed special bottom cover compounds, which reduce the power consumption by up to 20 - 40% (depending on the operating condition).

Bando Eco Carry Energy saving !! Reduced Tension



Type	Conventional Belt	Bando Eco Carry	Bando Eco Carry	
Belt Specification	Belt width(mm)	900	900	900
	Type of strength	ST-3000	ST-3000	ST-2500
	Cord Specification	7xSew19, 6.3 φ	7xSew19, 6.3 φ	7xSew19, 6.5 φ
	Cord size	67pcs, 12.5mm pitch	67pcs, 12.5mm pitch	50pcs, 17.0mm pitch
	Cover thickness(mm)	6.0 x 6.0	6.0 x 6.0	7.0 x 5.0
	Cover rubber type(top)	Abrasion resistance	Abrasion resistance	Abrasion resistance
	Cover rubber type(bottom)	Abrasion resistance	Low friction	Low friction
	Total belt thickness(mm)	18.3	18.3	19.6
	Belt weight(kg/m)	29.1	29.1	28.3
	Safety factor at Maximum Tensions	7.8	8.6	7.3
Joint	Joint step	2 steps (step=700mm)	1 steps (step=900mm)	1 steps (step=900mm)
	Necessary power P [kW]	858	725	713
Power	Electric power P*[kW]	953	806	793

HC 1500 SUPER HIGH HEAT CARRY



The variation by the heat aging is twice or more than HC710.

New super high heat resistant belts have been developed,, which is HC1500 (twice HC710 level)

Fig.1 It is possible to put it on 165°C condition making. About the change in breaking expansion EB

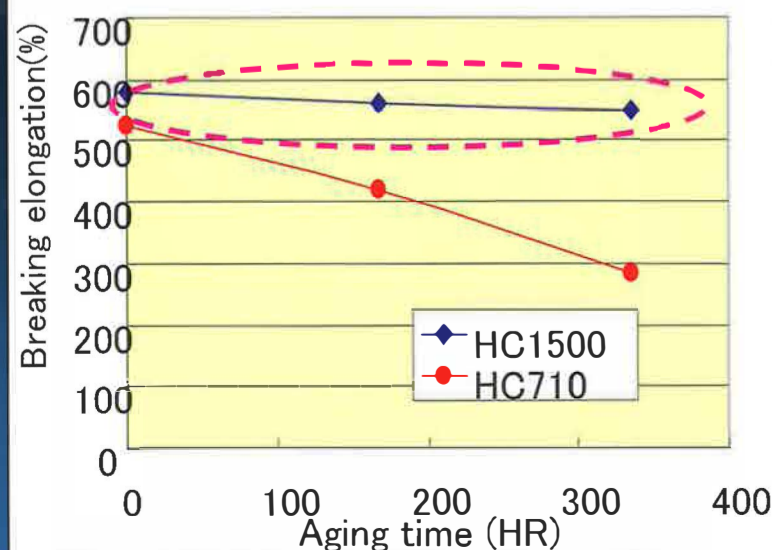
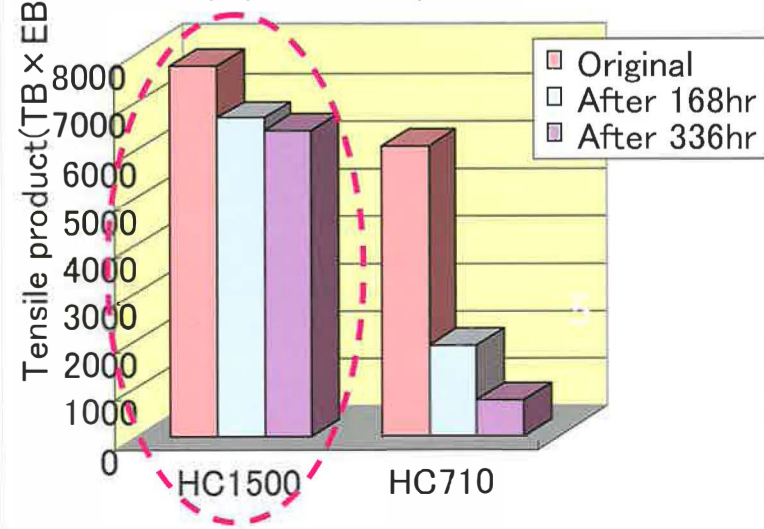

Fig.2 It depends on 165°C aging. About changing the tensile product



BANDO HEAT CARRY LINE UP HIGH HEAT & GOOD IN ABRASION

Application

Hot clinker, Sintered ore, Pellets, Dry materials

Features

1. Superior wear resistance in the high temperature.
2. Belt width : 100 ~ 3000mm(4~120inches)
3. Tensile strength : 200 ~ 1800N/mm
4. Carcass : HN, EP, ST (Steel Cord)



Bando Heat Carry Line up

Item	Main Polymer	Max Belt Surface Temp	Max Material Temp
HC513	SBR	Lump: 100°C Powder: 40°C	Lump: 150°C Powder : 70°C
HC730 (white color)	EPR	Lump: 100°C Powder: 40°C	Lump: 150°C Powder: 60°C
HC710	EPR	Lump: 180°C Powder: 70-130°C	Lump: 400°C Powder: 180°C
HC770	EPR <i>Superior in abrasion</i>	Lump: 180°C Powder: 70-130°C	Lump: 450°C Powder: 180°C

BANDO Heat & Fire Resistant Lineup (World New Introduction)

Combustion Test Result

Our heat resistant conveyor belt keeps combusting for a while after ignition.
Our heat and fire resistant conveyor belt extinguishes its fire soon after ignition.

“Prevention is Better Than Cure”

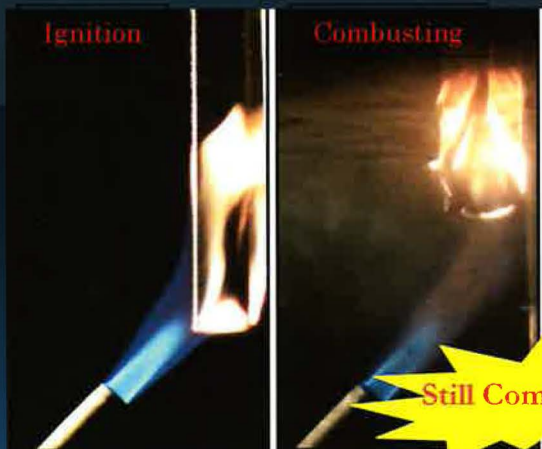

Heat Resistant Belt 513

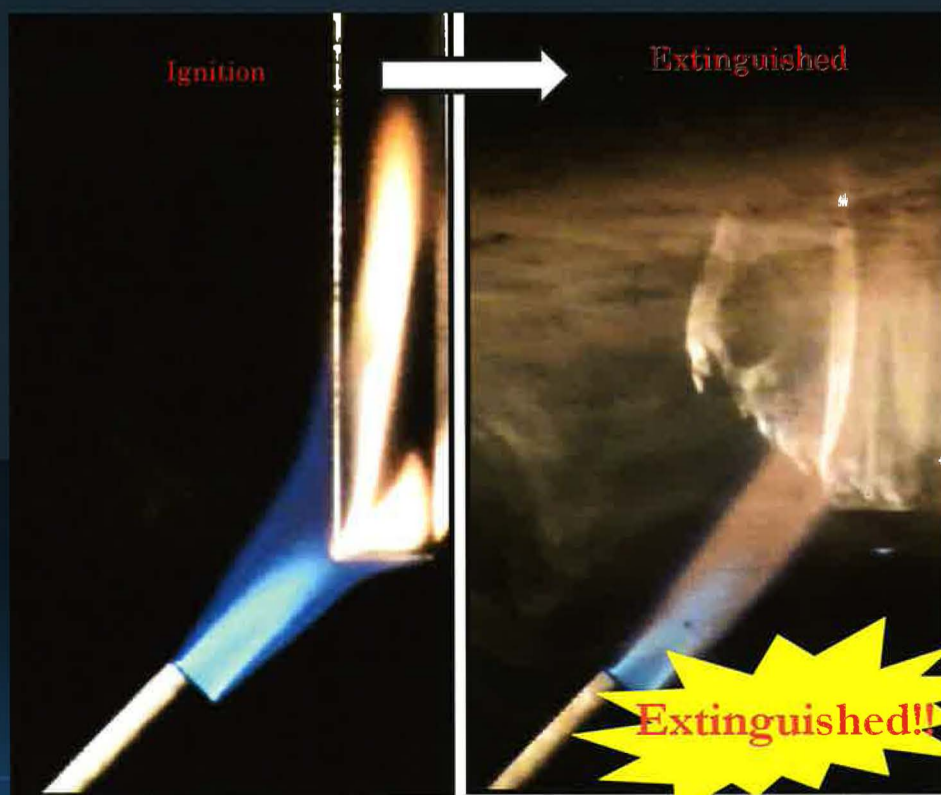

Heat and Fire Resistant Belt FR7500

BANDO Heat & Fire Resistant Lineup (World New Introduction)

Application

Coal, Cokes, Hot Clinker, Sintered Ore, Pellets

Features

Heat Resistance
Max. 400°C
(Material Temp.)



Fire Resistance
Complies with
the JIS K6324

Temp.	Item Name	Max Belt Surface Temp.	Max Material Temp.
Mid Temp.	FR7500	Lump: 100°C Powder: 40°C	Lump: 150°C Powder: 70°C
High Temp.	FR7700	Lump: 180°C Powder: 70-130°C	Lump: 400°C Powder: 180 °C

BANDO Gypsumboard Conveyor Belts

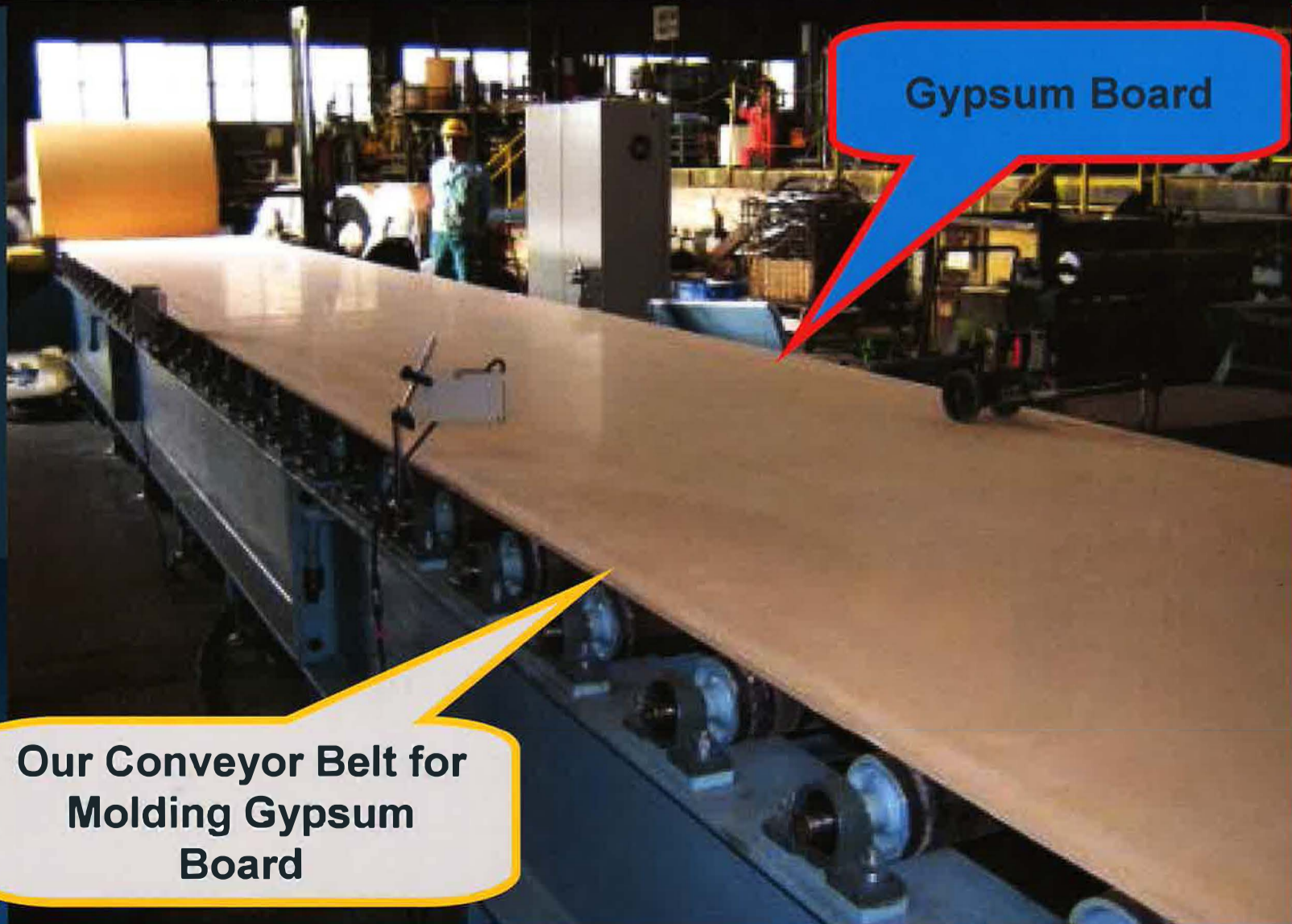

Gypsum Board

Our Conveyor Belt for
Molding Gypsum
Board

BANDO Gypsumboard Conveyor Belts

■ Application

Gypsum Board Molding

■ Features

High-precision Flatness



Extremely Precise Straightness



■ The Most Strict Tolerances

- (1) Width = $\pm 1\%$ of Nominal Number
- (2) Total Thickness = $\pm 1.5\text{mm}$ of Nominal Number
- (3) The Thickness Differences of Each Side = Less Than 0.2mm
- (4) The Difference of Total Thickness of the Whole Belt = Less Than 0.5mm
- (5) Flatness = Less Than 0.1mm of Dents and Bumps to the 100mm Length
- (6) Straightness: Less Than 10mm of Mistracking (in Sample Test)

BANDO Power Ace Aramid Combo V Belts

■ Application

Crusher, Pavement Milling, Wood Chipper, Mill, Any High Shock Load Applications

■ Features

Power Ace



1. Horse Power 30%↑↑
2. Breaking Strength 50%↑↑
3. Service Life 60%↑↑



Part Number Example



Nominal Dimension

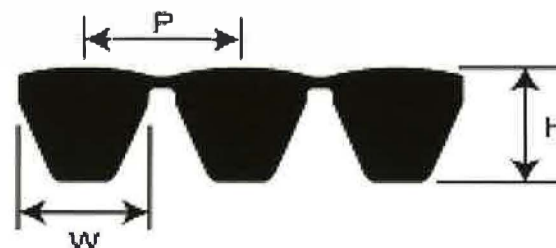

Belt Section	Top Width W (Inches)	Height H (Inches)	Pitch Between Belts P (Inches)	Belt Section	Size Range
5VK	0.62	0.63	0.69	5VK	600-3550
8VK	1.00	0.98	1.13	8VK	1250-5600

BANDO Power Ace Aramid Combo V Belts

Size Chart

5VK				8VK			
Description	Effective Outside Length (Inches)	Description	Effective Outside Length (Inches)	Description	Effective Outside Length (Inches)	Description	Effective Outside Length (Inches)
5VK600	60	5VK1500	150	8VK1250	125	8VK4500	450
5VK630	63	5VK1600	160	8VK1320	132	8VK4750	475
5VK670	67	5VK1620	162	8VK1400	140	8VK5000	500
5VK710	71	5VK1700	170	8VK1500	150	8VK5600	560
5VK750	75	5VK1800	180	8VK1600	160		
5VK760	76	5VK1900	190	8VK1700	170		
5VK800	80	5VK1920	192	8VK1800	180		
5VK850	85	5VK1955	195.5	8VK1900	190		
5VK860	86	5VK2000	200	8VK2000	200		
5VK900	90	5VK2080	208	8VK2120	212		
5VK920	92	5VK2120	212	8VK2240	224		
5VK950	95	5VK2150	215	8VK2360	236		
5VK960	96	5VK2200	220	8VK2500	250		
5VK970	97	5VK2240	224	8VK2650	265		
5VK1000	100	5VK2360	236	8VK2730	273		
5VK1060	106	5VK2500	250	8VK2800	280		
5VK1120	112	5VK2650	265	8VK3000	300		
5VK1180	118	5VK2800	280	8VK3150	315		
5VK1250	125	5VK3000	300	8VK3350	335		
5VK1280	128	5VK3150	315	8VK3550	355		
5VK1320	132	5VK3350	335	8VK3750	375		
5VK1400	140	5VK3550	355	8VK4000	400		
5VK1460	146			8VK4250	425		

Available up to 16 ribs Available up to 10 ribs

BANDO FLEXOWELL

HIGH INCLINATION Save space!

Application

Bulk Material, Powder, Oily Material

Features

- 1. Space Saving
- 2. Curves in any directions
- 3. Increased material volume
- 4. Noise reduction

Bando Flexowell Belt Component

- 1. Scope of base belt design
- 2. Size of sidewall

Type	Tensile strength (N/mm)	Belt width
Standard	200~1000	Belt width of 300-1600(mm) are standard width for each type
Heat resistant	315~800	
Oil resistant	200~630	

✘ For any options besides the standard, please feel free to contact us.

Type	Height (mm)	Remarks
N	60	Light Duty
	80	
	100	
	120	
S	120	Medium Duty
	160	
	200	
	240	
ES	300	Heavy Duty
	400	



3. Cleats

Cross section	All rubber		With reinforcement			With reinforcement	
	Type-T	Type-C	Type-T/TS	Type-TC/TCS	Type-C*	Type-TS-B	Type-TCS-B
Height (mm)	55, 75, 90, 110, 140		140 180 220	110 140 260	180 220 280	280 360	280 360

BANDO FLEXOWELL

HIGH INCLINATION Save space!

Bando Flexowell Conveyor Belt has sidewalls and cleats for vertical conveyor lines.

1. Space saving
2. Vertical Transportation
3. Increased material volume
4. Noise reduction
5. Cost efficiency



■ Main supply

2005	Power Plant	Japan	2400xXST3150x8x8x147m	FX-500ES, TBS-500B,P-500, NB-140, R-400
2005	Steel	Korea	800xXOE800/5+1x4x2x100m	FX-240S, TCS-220,P-250, NB-350, R-150
2006	Steel	Korea	750xXOE1250/6+1x8x4x261m	FX-200S, TCS-180,P-333, NB-400, R-100
2006	Power Plant	China	1200xXOE800/5+1x4x2x282m	FX-240S, TCS-220,P-333, NB-750, R-150
2014	Machinery	Malaysia	800xXOE630/4+1x4x2x60m	FX-200S, TCS-180,P-250, NB-450, R-100
2014	Power Plant	Thailand	900xXOE500/3+1x6x3x73m	FX-120S, TCS-110,P-250, NB-500, R-125
2014	Cement	Indonesia	1200xXOE630/34+1x4x2x88m	FX-240S, TCS-180,P-250, NB-770, R-140
2017	Power Plant	Japan	1600xXST2500x8x8x129m	FX-500ES, TCS-470-B, P-420, NB-800, R-300
2017	Power Plant	Korea	1200xXOE630/4+1x4x2x53m	FX-240S, TCS-220,P-200, NB-750, R-150



BANDO PIPE CONVEYOR BELTS

Dust prevention !!



■ Features

Tube conveyor which avoids material spillage

- 1) Closed belt system with belt transforming to pipe
- 2) New pipe conveyor applicable to conveying any types of materials
- 3) 3D curve. Steep slope transfer layout possible.
- 4) The closed construction makes pollution-free transfer possible
- 5) Reduction of conveyor length



BANDO PIPE CONVEYOR BELTS

Dust prevention!!

■ Bando pipe conveyor belt standard size

Pipe Diameter (mm Φ)	Belt Width (mm)	PLY x Top x Bottom (mm)	Belt type (N/mm)	Belt weight (kg/m ²)
150	600	2p x 3.0 x 2.0	125,160, 250,315	8.4
200	780	2p x 3.0 x 2.0 2p x 5.0 x 2.0	160,250, 315,400	9.1/10.9
250	1000	2p x 3.0 x 2.0 2p x 5.0 x 2.0	250,315, 400,500	10/11.8
300	1100	2p x 3.0 x 2.0 2p x 5.0 x 2.0	315,400 500,630	11.4/12.5
400	1600	4+1p x 6.0 x 2.0	800	19.3
600	2250	5+2p x 6.5 x 3.0	1000	26.6



This system has advantages as a conventional belt conveyor that is the most economical utilized most among all transport systems and has a other advantages to supplement demerits of a conventional belt conveyor regarding transport terms and performance.

The system does not transport materials on the troughed belt like a conventional BC but the troughed belt makes a pipe shape and encloses materials for transport after materials are charged on the flat belt.

The belt is flat at the tail end for material charging, is a pipe shape in the intermediate section, and returns flat for material discharging at the head end.

Return run belt also forms a pipe shape in the inter mediate section, which prevents dropping of materials attached to the carrying side belt.

BANDO STEELCORD CONVEYOR BELTS

■ Application

Long span, high strength, high capacity

■ Features

1. High Tensile Strength permits high tension operation
2. Excellent bending resistance
3. Extremely small elongation
4. Excellent dynamic adhesion
5. Excellent impact resistance
6. Better troughability
7. Longer in life of the spliced part.



CROSS SECTION

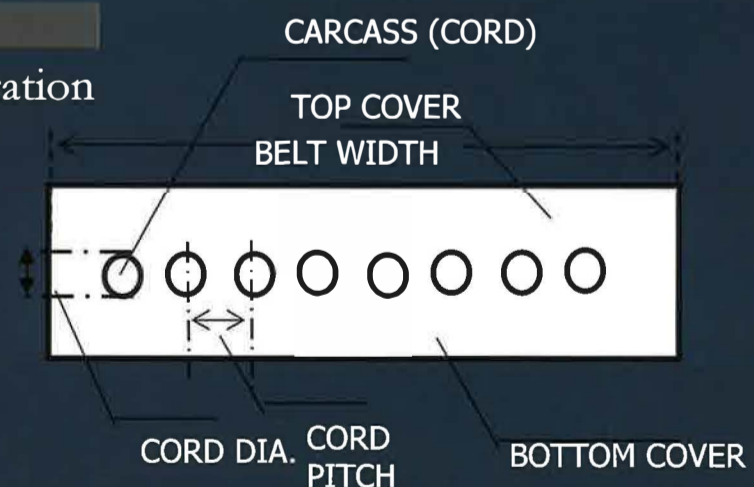

*Basic Specification Info

- Width
- Strength
- Top Cover Rubber Thickness
- Bottom Cover Rubber Thickness
- Cover Rubber Grade
- Belt Length
- Cord Construction
 - a. Cord Diameter
 - b. Cord Pitch
 - c. Number of Cords

BANDO STEELCORD CONVEYOR BELTS

Standard Belt Specification
ST member : ST500~ST6000 (Example of cord's construction)

(KN/m)	Cord Construction	JIS			DIN			AS		
		Cord Pitch	Cord Diameter	Cord tensile strength	Cord Pitch	Cord Diameter	Cord tensile strength	Cord Pitch	Cord Diameter	Cord tensile strength
		mm	inch mm	(KN)	mm	inch mm	(KN)	mm	inch mm	(KN)
ST1000	7 x 7	12.0	0.157 4.0	12.9	12	0.161 4.1	13.2	15.3	0.165 4.2	16.5
ST1250	7 x 7	12.0	0.177 4.5	16.1	14	0.193 4.9	19.2	15.3	0.181 4.6	20.6
ST2000	7 x 19	12.0	0.236 6.0	25.7	12	0.220 5.6	26.4	17.3	0.236 6.0	36.4
ST3150	7 x 19	15.0	0.319 8.1	50.4	15.0	0.319 8.1	52.0	19.4	0.346 8.8	64.6
ST4000	7 x 19	15.0	0.362 9.2	64.0	15.0	0.350 8.9	66.0	19.4	0.370 9.4	82.0
ST4500	7 x 19	16.0	0.398 10.1	76.8	16.0	0.382 9.7	79.2	19.4	0.398 10.1	92.3
ST5000	7 x 19	16.0	0.421 10.7	85.3	17.0	0.429 10.9	93.5		0.000	
ST5400	7 x 19				17.0	0.445 11.3	101.0			
ST5500	7 x 19	17.0	0.457 11.6	103.0						

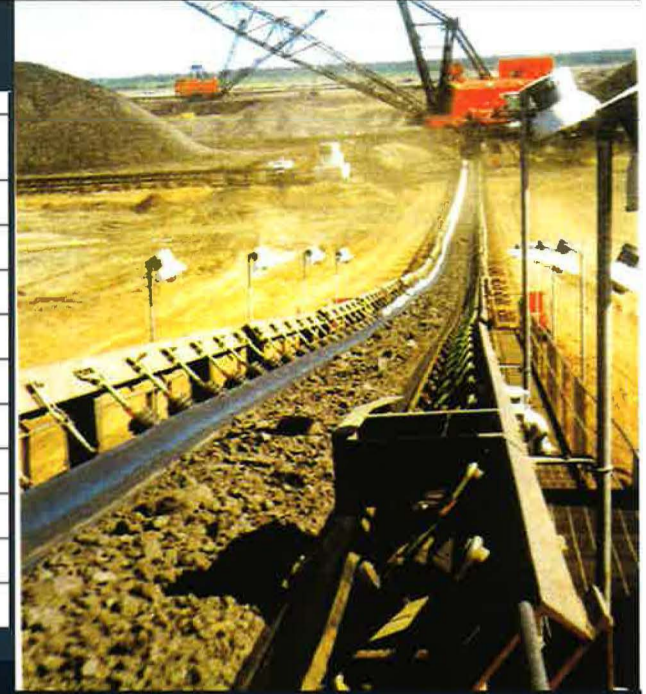

※Special designs are available upon customer's request

Cover rubber grade

Cover Rubber Grade	Features
STANDARD Grade-M BS Grade-M DIN Grade-X RMA Grade-1	Used as cover rubber for general and high-tension conveyor belts. Superior in abrasion resistance and cut and gouge resistance. Suitable for conveying large-sized lumps, sharp and rugged materials.
Grade-N BS Grade-N DIN Grade-Y	Used as cover rubber for general and high-tension conveyor belts as in the case of Grade-M. Superior in abrasion resistance, but inferior to Grade-M in cut and gouge resistance.
RMA-2	General light duty service. Moderately abrasive materials. Suitable for conveying small-sized materials.
HEAVY ABRASION Super Abrasion Resistance	Superior in abrasion resistance, but inferior to Grade-M in cut and gouge resistance. Suitable for conveying materials tending to cause fast wear on belts.

BANDO ROCK BELTS



Cover rubber

Special Reinforcement

Steel cords

Cover rubber

※Fabric conveyor belt is also available for this specification

Application

This belt has been designed for conveying lumps of earth or rocks at quarries or mines. It is used in conveyor lines for giant rock belt loaders, over size receivers from grizzly loading chute or ore receivers.

BANDO ROCK BELTS (for the building work of KANSAI International Airport)

Range of Production

Belt width : Max. 3000mm
 Tensile strength : Max. 6000N/mm
 Carcass : Steel cord, Special Nylon fabric
 Cover rubber : Ultra Impact Resistance (U.I.P.)



The picture was Provided by KANSAI INTERNATIONAL AIRPORT LAND DEVELOPMENT CO.,LTD.



Rock belt Supply record			
	Type of customer	Country	Belt Specification
2007	Nickel	Indonesia	2438xNS1500/3px8.0x3.2x151 m
2008	Nickel	Colombia	1800xNS1250/3px12.7x3.2x170m
2008	Nickel	Indonesia	2438xNS1500/3px8.0x3.2x151 m

At KANSAI Airport

2400mm x NS2400/3p x 25.0 x 8.0 UIP 114m 19

RIP DETECTOR type-7 (belt with device)

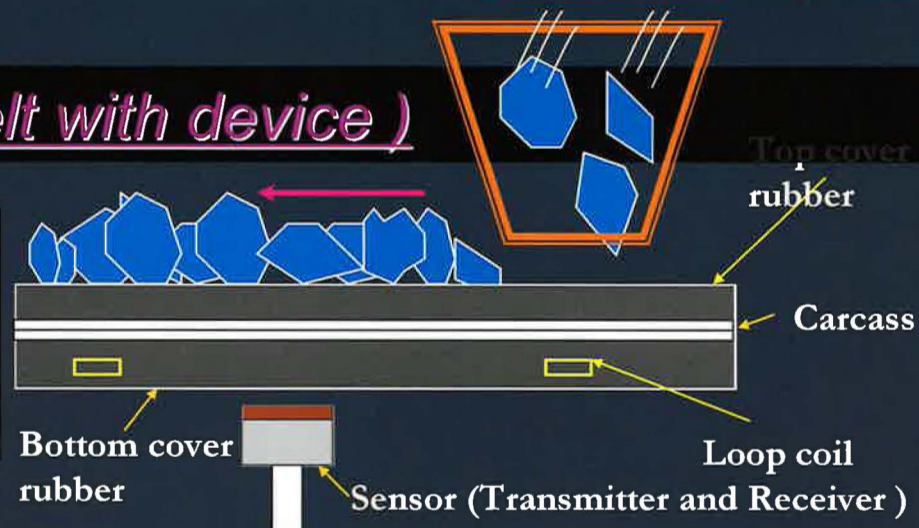
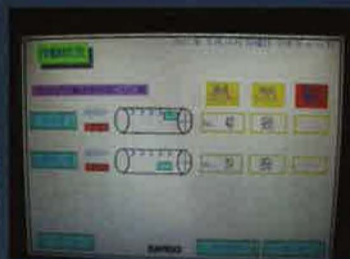

Principle

Loop coils are embedded in the belt monitored by electromagnetic detectors placed at the material loading chute points. When the conveyor runs, these loop coils pass over the detectors which generate output pulses. If the belt begins to rip, a sensor loop coil is also cut. As this cut loop coil passes over a detector, no pulse is generated. The lack of pulse is recognized by the control box, which signals the drive units to shut the conveyor down to minimize the further damage.

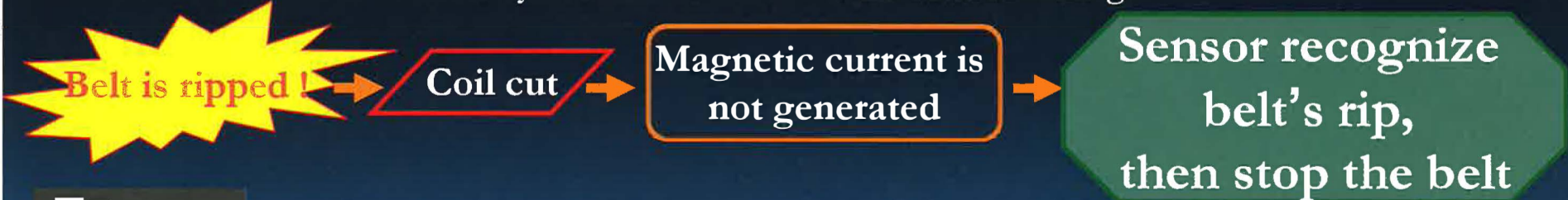

Features

1. Maximum 4 lines or less can be remotely intensively controlled.
2. The control box and the sensor can make it part up to 2km or less. (in case of remotely-type)

RIP DETECTOR type-7 (belt with device)

Layout

A start coil ①, and a number of rip detector coils spaced at a certain interval ②, are built into the conveyor belt; and the system comprises the sensor (transmitter and receiver) ③ which is mounted at the chute part, a pulse generator ④ mounted at the driven pulley, and a control box ⑤ for Processing signals from the sensor and the pulse generator.

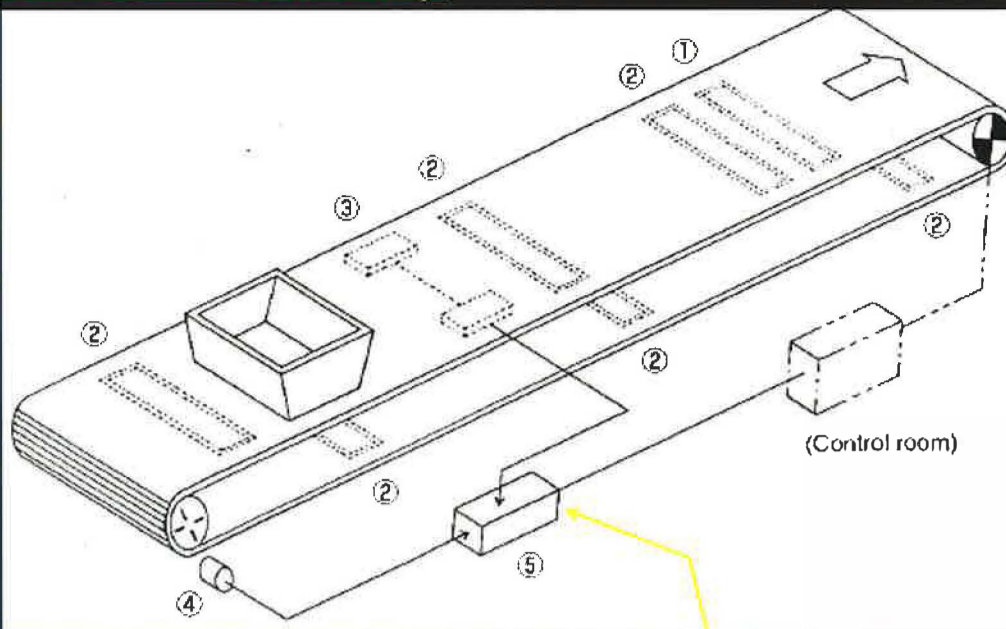

- ① Start coil
- ② Rip detector coil
- ③ Sensor
- ④ Pulse generator
- ⑤ Control box



BANDO SUNPAT ECO (cold splicing materials)

eco friendly and safety

For Cold Splicing

For Repairing of damaged point



Stop Halogen !!

Features

1. Halogen organic solvent is not used.
2. After splicing work, operating the belt will become possible in two hours.
3. High bending resistance and high bonding.
4. Efficient work(easy to dry it up)

Contents

Product Name	Contents per set
Cement : Sunpat ECO#310	0.7L / can
Hardner : Sunpat ECO#305	52g/bottle



■ **BANDO SUPERVISORY SERVICE**

Bando offers Technical Service at Site for Splicing Supervising.



•Improve your maintenance team's knowledge about splicing.

•Secure the best quality of splicing.

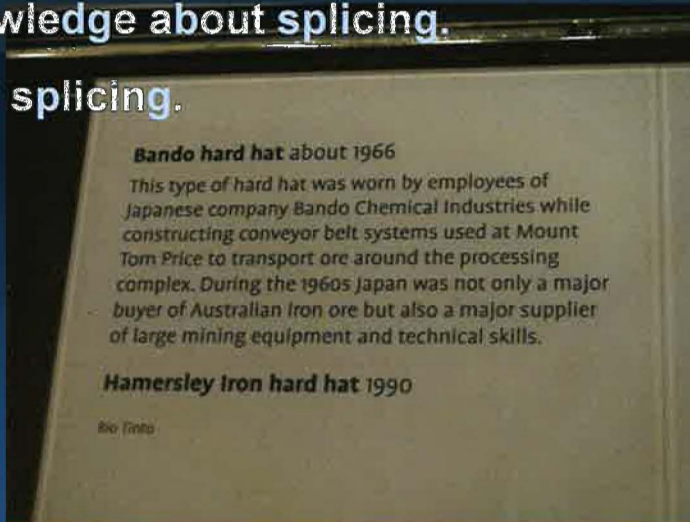

Bando hard hat about 1966
This type of hard hat was worn by employees of Japanese company Bando Chemical Industries while constructing conveyor belt systems used at Mount Tom Price to transport ore around the processing complex. During the 1960s Japan was not only a major buyer of Australian Iron ore but also a major supplier of large mining equipment and technical skills.

Hamersley Iron hard hat 1990

Bio Tinto

■ **BANDO FIELD SERVICE**

Do you want to last belt life longer ?

Bando offers Technical Service at site for Conveyor belt maintenance, advising for any troubles on your conveyor belting.

• Improve efficiency of your conveyor system.

• Improve your maintenance team's knowledge.

• Easy handling and maintenance



Bando is a qualified manufacturer which conforms to ISO standards.

Quality Assurance ISO 9001:2008 ISO14001:2004



CERTIFICATE OF APPROVAL

This is to certify that the Environmental Management System of:

Bando Chemical Industries, Ltd.
4-6-6, Minatojima Minamimachi, Chuo-ku, Kobe-shi,
Hyogo-ken, 650-0047
Japan

has been approved by Lloyd's Register Quality Assurance
to the following Environmental Management System Standards:

ISO 14001:2004, JIS Q 14001:2004

The Environmental Management System is applicable to:

Research, design, development and manufacture of power transmission belts & associated transmission units, (Rubber, PVC, TPU) conveyor belts, electro-photographic parts, molded plastic products, elastomer products & its composites, plastic films, rubber sheets, molded PU products, organoelectronic materials, nanoparticle and functional coating films.

This certificate is valid only in association with the certificate schedule bearing the same number on which the locations applicable to this approval are listed.

Approval Certificate No: YKA 0772509

Original Approval: 21 May 1999

Current Certificate: 1 January 2017

Certificate Expiry: 14 September 2018

Issued by: Lloyd's Register Quality Assurance Limited



Queen's Tower A, 10th Floor, 2-5-1, Minatomirai, Nishi-ku, Yokohama 220-6010, Japan
For and on behalf of: Trinity Park, Sickerhill Lane, Birmingham, B37 7ES, United Kingdom



CERTIFICATE OF APPROVAL

This is to certify that the Quality Management System of:

Bando Chemical Industries, Ltd.
4-6-6, Minatojima Minamimachi, Chuo-ku, Kobe-shi,
Hyogo-ken, 650-0047
Japan

has been approved by Lloyd's Register Quality Assurance
to the following Quality Management System Standards:

ISO 9001:2008, JIS Q 9001:2008

The Quality Management System is applicable to:

Design, development and manufacture of conveyor belts & light conveyor belts and assembly of associated conveying units. Design, development and manufacture of elastomer products and its composites for civil engineering & construction, railway track and general industrial & construction machinery. Design, development and manufacture of plastic films and its composites including decorative, marking, masking, insulation and sticking usage. Design, development and manufacture of blades, rollers and toner products, molded plastic products for electrophotographic machines & office equipment and power transmission belts (except automotive). Design, development and manufacture of organoelectronic materials, nanoparticle and functional coating films. Design, development and manufacture of bancollan squeegee and solid tires.

This certificate is valid only in association with the certificate schedule bearing the same number on which the locations applicable to this approval are listed.

Approval Certificate No: YKA 0953248

Original Approval: 2 May 1996

Current Certificate: 1 January 2017

Certificate Expiry: 14 September 2018

Issued by: Lloyd's Register Quality Assurance Limited



Queen's Tower A, 10th Floor, 2-5-1, Minatomirai, Nishi-ku, Yokohama 220-6010, Japan
For and on behalf of: Trinity Park, Sickerhill Lane, Birmingham, B37 7ES, United Kingdom

Requirement Sheet Yes, we can design specification for you.

BANDO CONVEYOR BELT REQUIRED INFORMATION		DATE:
TO:	FROM:	DEPT:
Description of the Requirements (New Installation, Replacement(CB/Other), etc)		
Customer Info		
Contact Name:	Dept:	
Company Name:	Email:	
Phone:	Fax:	
User Name:	Response Due:	
* Requirements of the Customer and Sales person (Q.C.D.S., Life, Span, Spec., Compatibility, etc)		
* Conveyed Material Characteristics		
Mine/Plant/Quarry:	Location:	
Material Conveyed:	Temp.:	
Max Size:	Bulk Density:	t/m3
Type of Oils/Chemicals:	Moisture %:	
Conveyor specifications		
Belt Description:		
* Belt Width (mm):	*Belt Speed:	
* Capacity Max t/h:	Ave. t/h:	
* Trough Angle x No of set pcs	Carrier:	Return:
Hours in Service per Day:	Days in Service per Week:	
* Any Requests:		
* Pulley Dia:	Head:	Tail:
	Tripper:	Snub:
	Drive:	Bend:
	Take Up:	Idlers Junction:
* Idlers Pitch:	Carrier:	Return:
* Drive:	System: Single / Tandem / Tail Head / Dual Drive	Capacity:
	Location: Head / Near the Head / Intermediate Tail / Near the Tail	
* Take-Up:	Type: Gravity / Power Winch / Screw	Effective Stroke:
	Location: Head / Near the Head / Intermediate Tail / Near the Tail	
* Chute:	Fall Height:	No. of Loading Spots:
		Impact Roller:
* Wash:	Yes - Moulded Edge	No
* Length:	L: Actual Ft.(L1+L2+L3)	L1
	Lh: Horizontal Ft.	L2
	H: Vertical Ft.	L3
		δ
		Lh
		H
Note: (In case of Replacement, describe the current belt spec and damage mode)		

* : These are Must Information.

BANDO FLEXOWELL BELT REQUIRED INFORMATION		DATE:
TO:	FROM:	DEPT:
Description of the Requirements (New Installation, Replacement(CB/Other), etc)		
Customer Info		
Contact Name:	Dept:	
Company Name:	Email:	
Phone:	Fax:	
User Name:	Response Due:	
* Requirements of the Customer and Sales person (Q.C.D.S., Life, Span, Spec., Compatibility, etc)		
* Conveyed Material Characteristics		
Mine/Plant/Quarry:	Location:	
Material Conveyed:	Temp.:	
Max Size:	Bulk Density:	t/m3
Type of Oils/Chemicals:	Moisture %:	
Conveyor specifications		
Belt Description:		
* Belt Width (mm):	Belt Speed	
* Recess Width:	Sidewall Height	
* Capacity Max t/h:	Ave. t/h:	
Hours in Service per Day:	Days in Service per Week:	
* Any Requests:		
* Pulley Dia:	Head:	Tail:
	Tripper:	Snub:
	Drive:	Bend:
	Take Up:	
* Idlers Pitch:	Carrier:	Return:
* Disk Pulley:		
* Take-Up:	Type: Gravity / Power Winch / Screw	
* Wash:	Yes - Moulded Edge	No
* Configuration:	Straight I L S F-Lift InnerConveyor PylonLift	
	L: Actual Ft.(L1+L2+L3)	L1
	Lh: Horizontal Ft.	L2
	H: Vertical Ft.	L3
		δ
		Lh
		H
* Note: (if Replacement, the present Spec. & the damage condition & the life span info. are needed)		

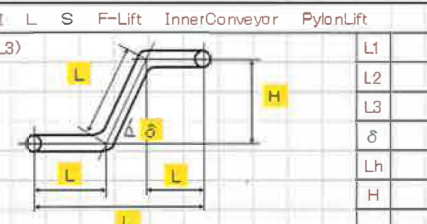



※ The content might change without notice.

※ The content is not allowed to be reprinted or reproduced without the permission of Bando Chemical Industries, LTD.

All Contents Copyright (C) BANDO CHEMICAL INDUSTRIES, LTD.



chainanddrives.com.au
support@chainanddrives.com.au

