

TRANSFLUID



TRANSFLUID[®]
industrial & marine

CHAIN & DRIVES[®]



KSL
VARIABLE FILL FLUID COUPLINGS



drive with us

INTRODUCTION

Transfluid designed the **KSL** series variable fill fluid coupling to overcome difficulties experienced during 'start up' and 'speed variation' operation for medium or high powered machines, driven by electric motors or internal combustion engines.

WORKING OPERATION

Extremely efficient performance is achieved utilizing the KSL's very simple and effective principle. Oil, as the power medium, is pumped from a sump to the hydrodynamic coupling circuit, where it is finally 'drained-off' through a series of orifice plugs, back into the sump.

The variable fill principle:

By controlling the oil flow to the working circuit through a frequency converter, changes occur inside the coupling's working circuit which alter the coupling's slip characteristics dramatically softening the 'start up'.

Torque limiting function:

Having all the same advantages of fluid couplings, variable fill-drain type fluid couplings build up torque gradually.

Disconnect:

Interrupting the oil flow into the coupling empties the working circuit and disconnects the input from the output.

In summary, it is possible to:

- have a long start up acceleration, up to several minutes, for high inertia machines.
- position the driven machine for loading, unloading and maintenance.
- obtain sequential starting for more than one drive motor.
- adjust or limit the torque
- disconnect the load even with the motor running
- use for conveyors, for the reduction of the tension to a minimum level or the possibility of running at an inspection speed.
- vary the speed within a 5:1 range for centrifugal machines.

CHARACTERISTICS

Soft starter

The KSL working circuit is gradually filled by oil from an empty condition to a fully filled one. Such behaviour provides an extremely soft controlled start up, especially with high inertia machinery. The KSL variable oil feed system is controlled by a frequency converter during the ramp up, producing ideal soft starting.

Accurate speed variation

By remote signal, the KSL always guarantees output speed accuracy, as required by the operator or control system. Speed variation is also possible by manual flow control valve operation.

A frequency converter electronic bypass is supplied standard

Vibration Dampening

One of the most important characteristics of KSL fluid coupling is its torsional vibration dampening effect, protecting both the driven gear box, fan, or pump machinery, as well as the motor or engine.

Overload Protection

This is a fluid coupling advantage and a big benefit to users.

High Efficiency

The KSL is an extremely efficient device compared to the constant filled type fluid coupling, because the working circuit volume is controlled at the fullest possible level to maintain a very small slip rate.

The Transfluid JET RECOVERY POWER system, provides increased efficiency and lower noise level thanks to an improved oil path through the orifice plugs.

Shaft Labyrinth Sealing

This type of seal helps the KSL series to be a low maintenance machine.

Easy of Maintenance

Thanks to its split casing design, it is possible to remove the complete fluid coupling impeller assembly without having to move either the motor/engine or driven machinery, saving the need for realignment and costly down time.

Optional

Auxiliary Lubrication unit for prime mover and/or driven machine bearing.

ATEX EEx

Upon request.

APPLICATIONS

Mills, crushers, conveyors, fans, blowers, pumps, compressors, centrifuges, mixers, generators, marine propulsion drives.

- Can Bus upon request

SELECTION

To correctly select the KSL, Transfluid needs to know the following data:

- motor/engine type, power and speed
- driven machinery type, power, speed and inertia
- output speed range
- environmental conditions
- cooling water/air characteristics
- drive and driven shaft dimensions and tolerances
- available voltage for motors and instruments

AUTOMATIC

All parameters under control such as:
speed, start up modulation, oil pressure, oil
temperature, filter clogging, oil level, heat
exchanger pump thermostatic control.

OR SEMIAUTOMATIC / MANUAL OR MANUAL

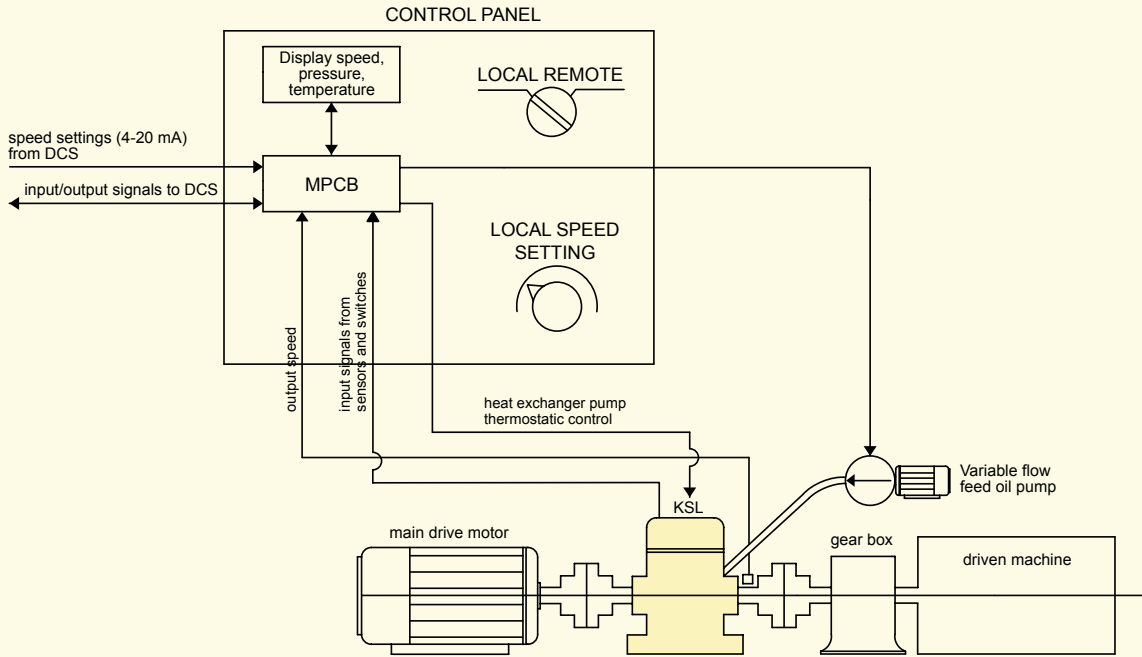

- 1 - variable flow feed pump with variable frequency converter
- 2 - lubrication oil pump
- 3 - heat exchanger oil pump
- 4 - pressure gauge
- 5 - pressure differential transducer
- 6 - bleeding orifices
- 7 - heat exchanger
- 8 - oil level switch and gauge
- 9 - max temperature switch

- 10 - feed oil filter
- 11 - lub. oil filter
- 12 - vacuum switch
- 13 - pressure gauge
- 14 - temperature gauge
- 15 - thermistor Pt100
- 16 - speed sensors
- 17 - heat exch. pump thermostat
- 18 - manual flow control valve

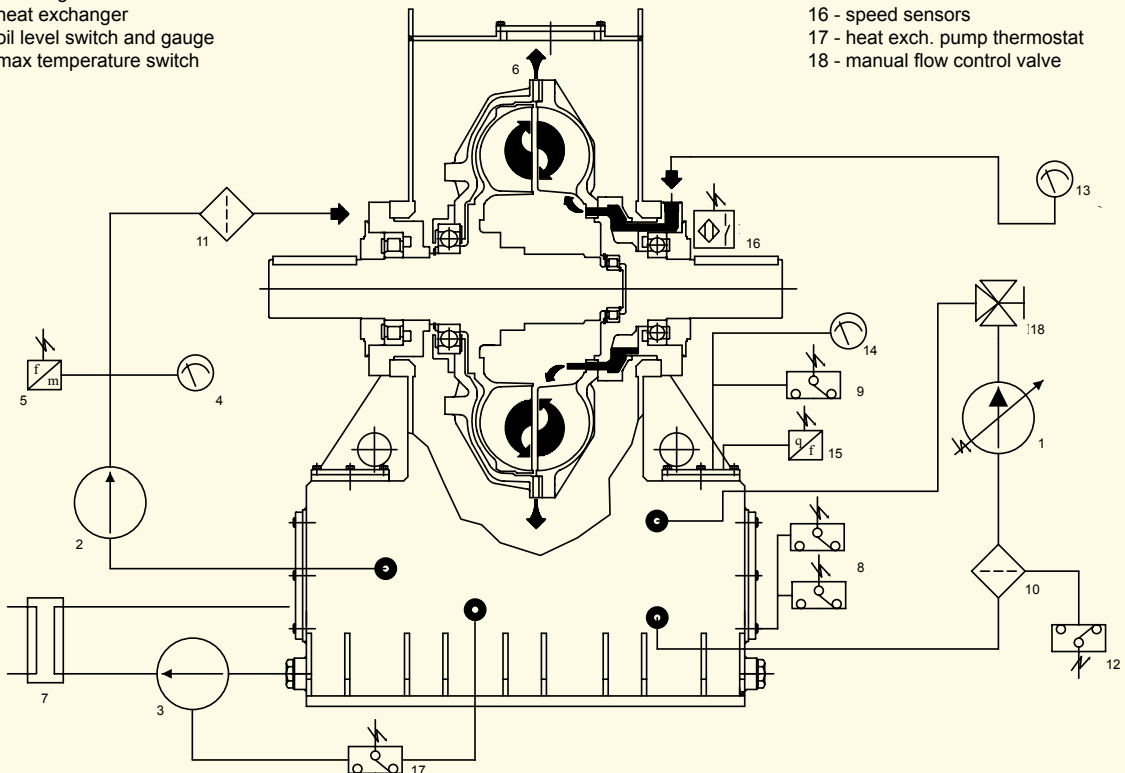

PERFORMANCES

MOTOR POWER - kW

rpm	Size / kw max	21 HS	D21 HS	27	29	34	D34	46	D46
1000				200	360	750	1300	1800	3500
1200				360	630	1300	2300	3000	4000
1500		-	-	700	1250	2000	2800		
1800				1200	1600	2400*	3350*		
3000		1900	3500						
3600		3000	4500						

* With steel impellers

NOTE: Standard squirrel cage motors should NOT be derated
 Efficiency of electric motor is NOT affected by KSL application
 Value of electric motor efficiency can be found in manufacturer's catalogue
 Slip can vary ±10% according to driven machine characteristics

CENTRIFUGAL APPLICATION

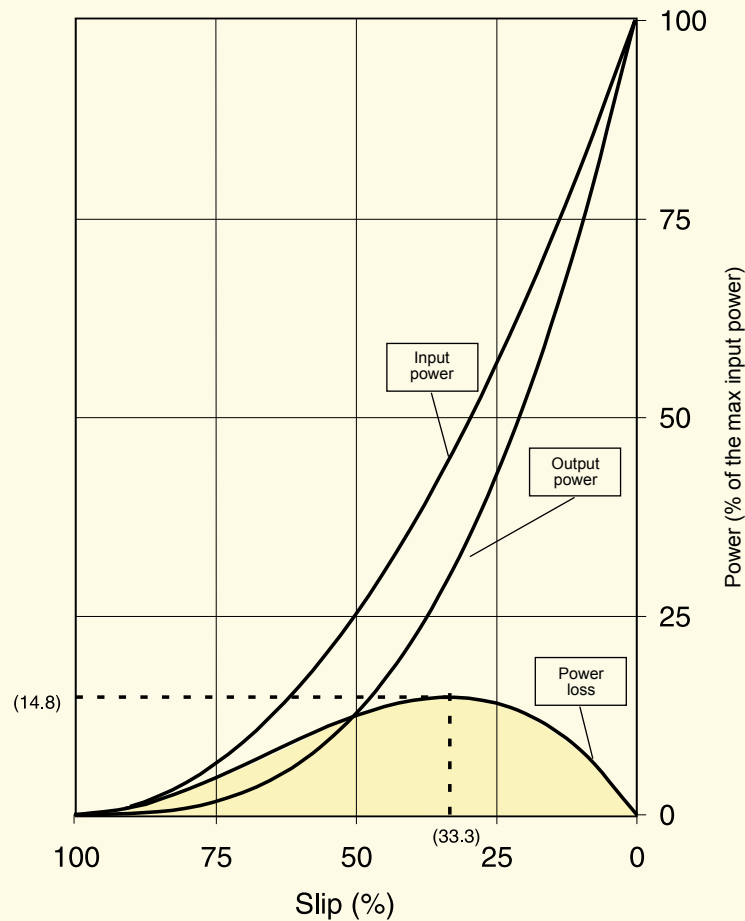

LOSSES %	OUTPUT SPEED %
0	100
8.1	90
12.8	80
14.8	70
14.4	60
12.5	50
9.6	40
6.3	30
3.2	20

average value = 9.6

$$\text{input} = K n_2^3 + K (n_1 - n_2) n_2^2 \quad K = \text{max input power} / n_1^3$$

$$\text{output} = K n_2^3 \quad n_1 = \text{input speed}$$

$$\text{losses} = K (n_1 - n_2) n_2^2 \quad n_2 = \text{output speed}$$

BOILER FEED WATER PUMPS, PIPE LINE PUMPS, CENTRIFUGAL GAS COMPRESSORS,
CITY FEED WATER PUMPS, RECYCLING PUMPS, ALL FANS AND BLOWERS

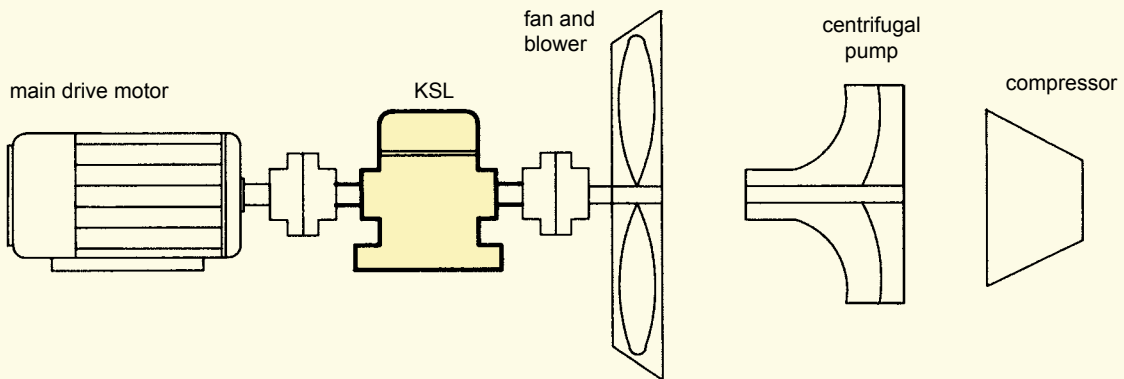

HAMMER MILLS, BALL MILLS, STONE CRUSHERS, METAL SHREDDERS, WOOD CHIPPERS

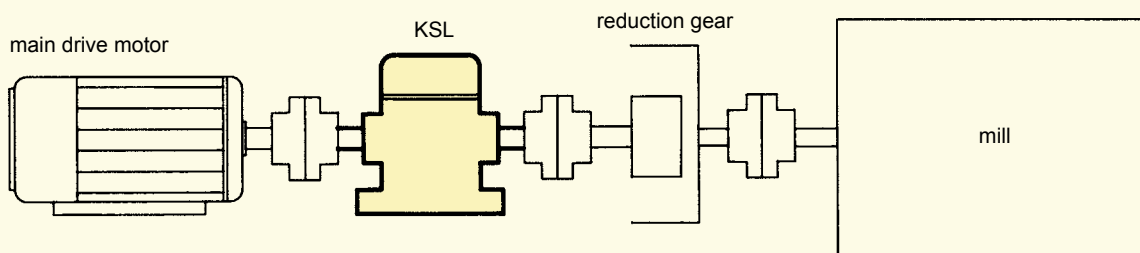

VOLUMETRIC MACHINES

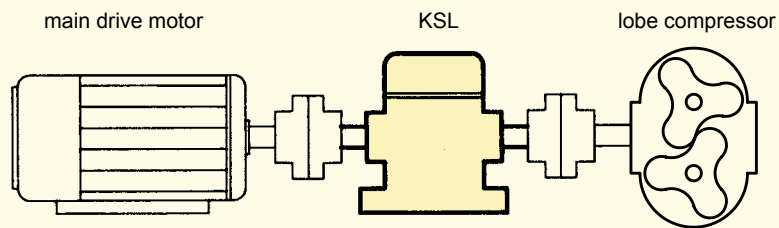

BELT CONVEYORS

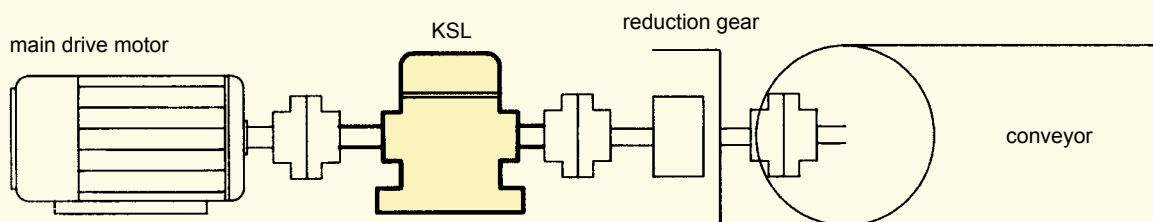

DIMENSIONS

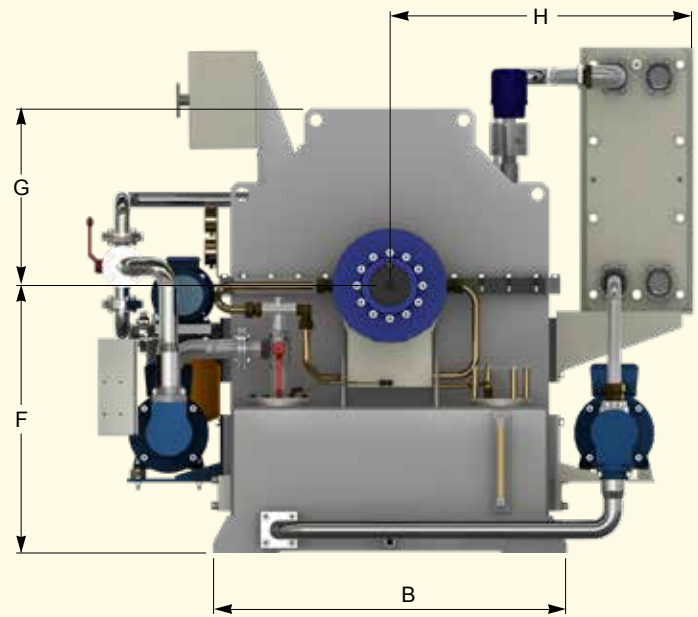
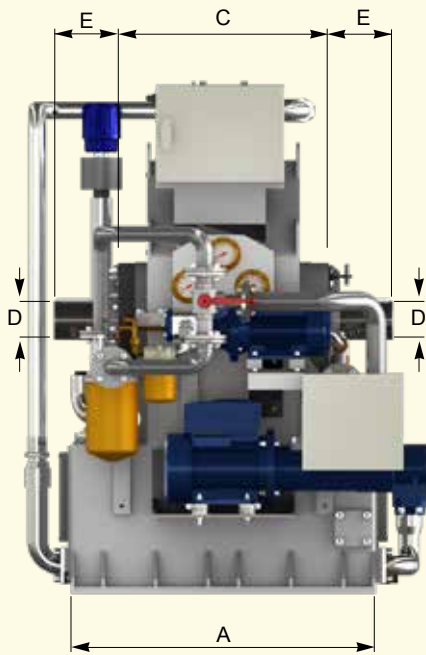

size ↕ Dimensions (mm) ⇨

	A	B	C	D	E	F	G	H	Weight kg (without oil)	Oil I
21 HS	940	1500	580	100	170	700	490	1150	1100	400
D21 HS	1300	1710	775	120	170	725	490	1200	2900	600
27/29	900	1100	660	120	170	850	550	1000	1200/1300	300
34	1050	1300	790	140	220	1000	670	1050	2100	450
D34	1400	1300	1040	160	250	1100	670	1050	3000	850
46	1420	1700	1060	180	270	1300	900	1200	4850	1000
D46	1800	1700	1400	200	300	1300	900	1200	5600	1300

WEIGHT ACCORDING TO STANDARD VERSIONS
DIMENSIONS ARE SUBJECT TO ALTERATION WITHOUT NOTICE

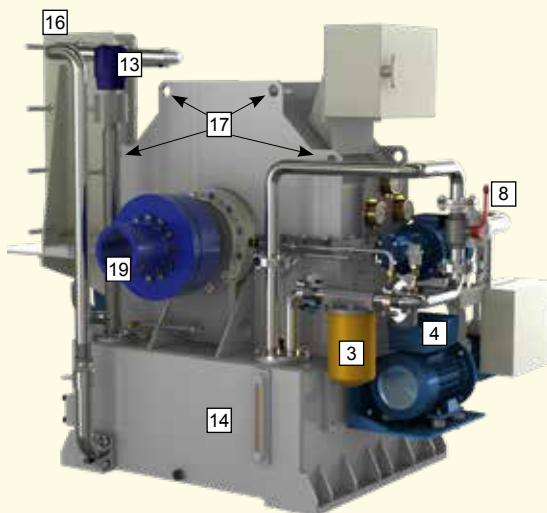

- 1 Variable flow pump
- 2 Lubrication oil pump
- 3 Feed filter with vacuum switch
- 4 Lube filter with differential pressure transducer
- 5 Feed pressure gauge
- 6 Lube pressure gauge
- 7 Temperature gauge
- 8 Filter by-pass valve
- 9 Proximity switch
- 10 Temperature switch
- 11 Drain tap
- 12 Electric wiring box
- 13 Breather
- 14 Level switch and gauge
- 15 Manual control valve
- 16 Cooler
- 17 Lifting ears
- 18 Cooler pump
- 19 Aligment couplings

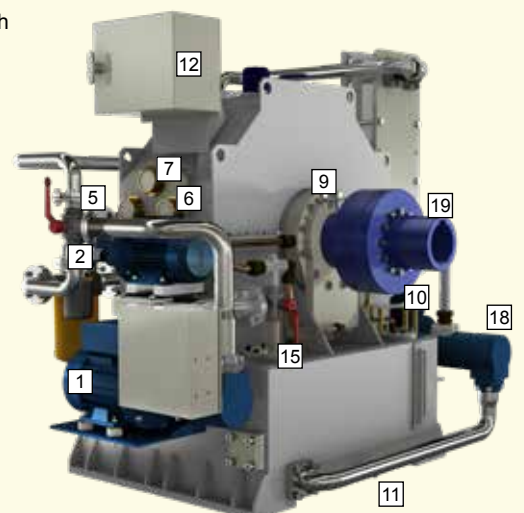



2x D34 KSL, 2000 kW - 1200 rpm, Fan drive (Brazil)



2x 34 KSL, 630 kW - 1000 rpm, Ceramic mill (Italy)

Tables for the preliminary selection of the coolers:

- KSL with oil cooler motor pump (2 poles motor)
- Refer to available speed drive or start up drive column
- Max power = max power at max speed
- Output water temperature 35°C
- For power higher than those listed below, please apply Transfluid

VARIABLE SPEED APPLICATION			
Fluid Coupling max. power (kW)	Water-Oil Cooler Model	Required Water Flow (l/min) at 25°C	Cooler Oil Pump Model
700	08084 • SP3-31**	220	GR55SMT250L
800	08120 • SP3-41 **	251	GR55SMT300L
900	08120 • SP3-41 **	282	GR55SMT380L
1000	08120 • SP3-41 **	314	GR55SMT380L
1200	10098 • SP3-51 **	377	GR55SMT440L
1400	12078 • SP3-71 **	440	GR55SMT500L
1600	12078 • SP3-71 **	502	GR55SMT600L
1800	12098 •	565	GR55SMT800L
2000	12098 •	628	GR55SMT800L

START-UP APPLICATION			
Fluid Coupling max. power (kW)	Water-Oil Cooler Model	Required Water Flow (l/min) at 25°C	Cooler Oil Pump Model
700	06060 • SP3-11 **	55	GR40SMT100L
800	06060 •	62	GR40SMT100L
900	06060 • SP3-11	70	GR40SMT100L
1000	06060 • SP3-11 **	78	GR40SMT100L
1200	06060 • SP3-11 **	94	GR40SMT150L
1400	06096 • SP3-19 **	110	GR40SMT150L
1600	06096 • SP3-31 **	125	GR40SMT150L
1800	08084 • SP3-31 **	141	GR40SMT180L
2000	08084 • SP3-31 **	157	GR40SMT180L

• Tube bundle heat exchanger
 ** Plate heat exchanger

Before ordering, ask TRANSFLUID for a dedicated check of the heat exchanger

DISTRIBUTED BY





CHAIN & DRIVES®
 COMPLETE BEARINGS & POWER TRANSMISSION

SERVICE & SUPPORT

Wangara, WA Welshpool, WA Arndell Park, NSW
 +61 8 9303 4966 +61 8 6314 1155 +61 2 9674 8611
 support@chainanddrives.com.au salesnsw@chainanddrives.com.au

chainanddrives.com.au

LOCAL DISTRIBUTOR