

VARVEL®
MOTION CONTROL SINCE 1955

technology made in Italy



DISTRIBUTED BY 

CHAIN8, RBJ♦®

& POWER TRANSMISSION

SERVICE & SUPPORT

Wangara, WA	Welshpool, WA	Arndell Park, NSW
+61 8 9303 4966	+61 8 6314 1155	+61 2 9674 8611
support@chainanddrives.com.au	salesnsw@chainanddrives.com.au	

chainanddrives.com.au

GB

RG



Technology Made in Italy

Since 1955 Varvel has been making speed reducers and variators for light industry applications. Reliable partner in power transmission equipment offers also customized solutions always according to a socially responsible company values. Modularity and flexibility lead Varvel products by a unique kit form, common to all gearbox series. This feature allows distributors an easier job to set up required products in few minutes.

RG

LOW BACKLASH PLANETARY GEARBOXES

Coupling to brushless, DC and IEC/NEMA standard motors



Planetary gearboxes RG

Description

One-piece body
of hardened and tempered steel
and modular design
of input and output flanges

Gears

- one-piece broached ring gear
- sun and planet gears of alloy steel, case-hardened and skiving finished

Bearings

- 2Z ball types on input shaft
- 2RS ball types on output shaft
- needle types between planet gear and planet shaft

Planet carrier

- overhanging with high stiffness



Input
Servo, DC, IEC and NEMA
motor adapters
with clamping clutch

Output
flanges fitted
on output bearing spigot

Temperature
Bearings -40 / +100 °C
-40 / +212 °F
Ambient -15 / +40 °C
+5 / +104 °F

The planetary speed reducers, Series RG, are designed as one and two stage versions, with hardened and tempered steel housing and broached internal gear.

Manufactured to latest ISO engineering design specifications is checked by computer-aided structural analysis for deflection and stress distribution.

Significant strains caused by the effects of both torque and external loads do not stress the monolithic housing, substantially improving the sealed surfaces.

The planetary speed reducers RG are made of alloyed steel gearing, hardened and tempered; the planetary gear shafts of tempered steel.

Motor coupling options are available with clamping clutch, input flange and bush adapters.

Single-setup machining on state-of-the-art CNC production lines, the most recent calculation techniques and process controls give superior operational reliability, maximum output torques, high overhung and thrust load capacity, and long working life-time.

Planetary gearboxes RG

Description

GENERAL SPECIFICATIONS

C_t [Nm / arcmin]	Torsional rigidity
F_{r2} [N]	Catalogue radial load (output)
F_{a2} [N]	Catalogue axial load (output)
F_s	Shock factor
i	Reduction ratio (finite values)
J_1 [kgcm ²]	Moment of inertia at gearbox input shaft
T_{2acc} [Nm]	Gearbox max. output acceleration torque (S5 operation - max. 1000 cycles per hour)
T_{2ISO} [Nm]	Gearbox nominal output torque according to ISO 6336 (S1 continuous operation)
T_{2max} [Nm]	Gearbox emergency output torque (max. 1000 times in gearbox life)
n_1 [min ⁻¹]	Input speed
n_{1max} [min ⁻¹]	Max. input speed
P [kg]	Weight (average reduction ratio)
η	Efficiency
j	Angular backlash

Planetary gearboxes RG

Descrizione

TECHNICAL SPECIFICATIONS

Size, RG...	051	052	071	072	091	092	121	122
One-stage ratios [i]	3, 4, 5, 7, 9, 10							
Two-stage ratios [i]	12, 15, 16, 20, 25, 28, 30, 35, 40, 45, 50, 63, 70, 81, 90, 100							
Output torque [Nm]	6		18		45		110	
Acceleration torque [Nm]	12		35		90		220	
Max. torque [Nm]	26		75		190		480	
Radial load (OHL) [N]	650		1450		2400		4600	
Axial load [N]	700		1550		1900		4000	
Average lifetime [h]	20,000		20,000		20,000		20,000	
Noise level [dB A]	< 68		< 70		< 72		< 74	
Nominal input speed [min ⁻¹]	4000		3700		3400		2600	
Max. input speed [min ⁻¹]	6000		6000		6000		4800	
Torsional stiffness [Nm/arcmin]	0.93	0.81	3.38	2.89	9.25	7.59	24.60	21.20
Standard backlash [arcmin]	≤ 8	≤ 12	≤ 8	≤ 12	≤ 8	≤ 12	≤ 8	≤ 12
Weight [kg]	0.8	1.0	1.8	2.2	4.0	4.9	9.0	11.2
Rotation	One-stage: opposite rotation of input vs output shaft Two-stages: same rotation of input vs output shaft							
Protection class	IP44							
Lubrication	Long-life synthetic grease: Klüber GE46							
Painting	RAL 9005 orange peel Black							

DESIGNATION

F	RG	071	3	IEC56	B5
					Motor mount
					Motor frame (IEC / NEMA)
					Reduction ratio
					Gearbox size

F = Input flange

S = No input flange

M = Gearmotor

Planetary gearboxes RG

Duty cycle - Operation

Duty cycle

The correct investigation of actual duty cycle is the basic rule in planetary gearbox selection. An operative and basic duty cycle can be pictured as follows: :

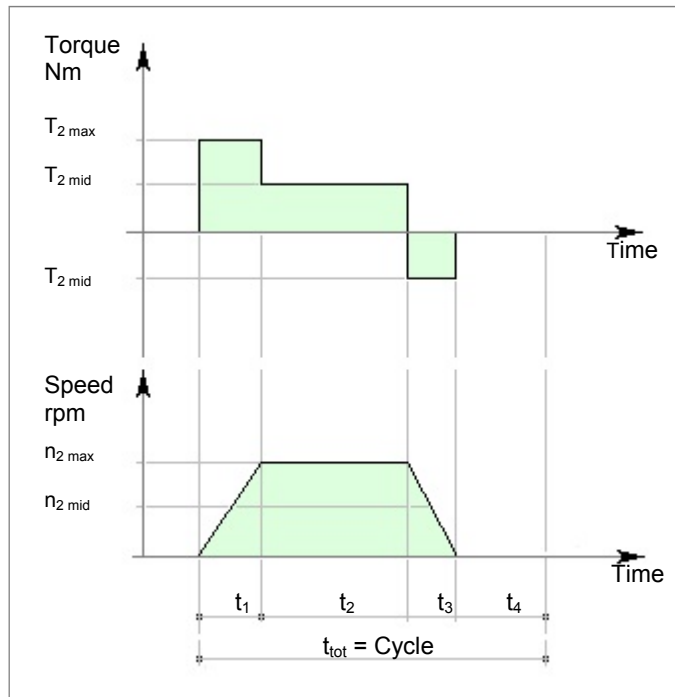

where:

- $n_{2\ max}$ [rpm] - Max. speed
- $n_{2\ mid}$ [rpm] - Average speed
- t_1 [s] - Acceleration time
- t_2 [s] - Operation time
- t_3 [s] - Deceleration time
- t_4 [s] - Pause time
- $T_{2\ max}$ [Nm] - Max. acceleration torque
- $T_{2\ mid}$ [Nm] - Operation torque
- $T_{2\ dec}$ [Nm] - Deceleration torque

Operation

The operative duty cycle fixed, there are two operation ways:

- **Continuous (S1)** - if $S_p > 60\%$
 - or $S_t > 20$ minutes
- otherwise
- **Intermittent (S5)** - if $S_p < 60\%$
 - and $S_t < 20$ minutes

where:

- S_p - per cent operation time
- S_t - operation time
- min - minutes

$$S_p = \frac{t_1 + t_2 + t_3 + t_4}{t_{tot}} * 100 \quad [\%]$$

$$S_t = \frac{t_1 + t_2 + t_3 + t_4}{60} \quad [\text{min}]$$

Planetary gearboxes RG

Gearbox selection

Gearbox selection

Gearbox selection is made according to the following formulas for Continuous or Intermittent operation.

S1 - Continuous operation

for $S_p > 60\%$ or $S_t > 20$ min

$$T_{2\text{ nom}} = \frac{T_{1\text{ nom}} * i * \mu}{0.65}$$

$$T_{2\text{ nom}} > T_{2\text{ ISO}}$$

$$n_{2\text{ eqv}} = n_{2\text{ nom}}$$

where:

$T_{2\text{ nom}}$ [Nm] = Gearbox nominal torque
 $T_{1\text{ nom}}$ [Nm] = Motor nominal torque
 $T_{2\text{ ISO}}$ [Nm] = Gearbox nominal torque according to ISO
 $n_{2\text{ nom}}$ [rpm] = Output nominal speed
 $n_{2\text{ eqv}}$ [rpm] = Output average speed

S5 - Intermittent operation

for $S_p < 60\%$ or $S_t < 20$ min

$$T_{2\text{ acc}} \geq T_{1\text{ acc}} * i * f_s * \mu$$

$$Z_h \geq \frac{3600}{t_1 + t_2 + t_3 + t_4}$$

$$T_{2\text{ eqv}} = \sqrt[3]{\frac{T_{2\text{ max } 1}^3 * n_{2\text{ mid } 1} * t_1 + \dots + T_{2\text{ max } n}^3 * n_{2\text{ mid } n} * t_n}{t_1 * n_{2\text{ mid } 1} + \dots + t_n * n_{2\text{ mid } n}}}$$

$$n_{2\text{ eqv}} = \frac{n_{21} * t_1 + \dots + n_{2n} * t_n}{t_1 + \dots + t_n}$$

$n_{2\text{ eqv}}$ [rpm] = Cycle equivalent speed

$n_{2\text{ mid}}$ [Nm] = Average speed

$t_1 \dots t_4$ [s] = Acceleration, operation, deceleration, pause times

where:

$T_{2\text{ acc}}$ [Nm] = Gearbox max. acceleration torque
 $T_{1\text{ acc}}$ [Nm] = Motor max. acceleration torque
 i [...] = Reduction ratio
 f_s [...] = Shock factor (see graph)
 η [...] = Gearbox efficiency
 Z_h [1/h] = Cycle number per hour
 $T_{2\text{ eqv}}$ [Nm] = Equivalent torque, resultant by individual torques of duty cycle
 $T_{2\text{ max}}$ [Nm] = Max. torque
 n_{2n} [rpm] = Cycle speed
 t_n [s] = Cycle times

Shock factor

Shock factor is a service factor that keeps into account rapid motion inversions associated with quick acceleration times. Such overloads must be considered when sizing.

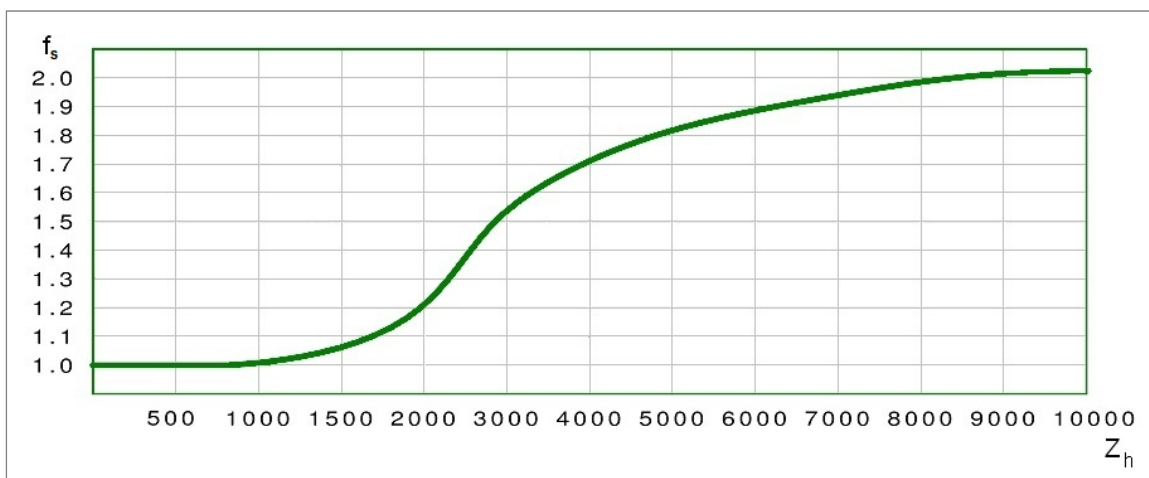

f_s - Shock factor
 Z_h - Cycle numbers per hour

Planetary gearboxes RG

Motor fitting

Step 1

- Remove the protection cap.
- Rotate the gearbox input bush until tightening screw head is aligned with the access hole of the flange.
- Loosen the tightening screw.
- Correctly align the motor shaft to the gearbox.
- Fit the motor vertically.



Step 2

- Apply anti-loosening paste (Loctite 243 or similar) on screw thread.
- Tighten the screws according to table torque values.
- Screw resistance class: recommended 12.9

Screw diameter	[Nm]
	12.9
M4	4.9
M5	9.7
M6	16
M8	40
M10	77



Step 3

- Set torque wrench to measure tightening torque value as shown.
- Tighten clamp screw as listed.

Gearbox type	Screw class 12.9	
	Type	[Nm]
RG 051/052	VC 4.12	4.9
RG 071/072	VC 5.20	9.7
RG 091/092	VC 6.30	16
RG 121/122	VC 8.40	40

- **VC screw type:**
Socket-head screw (Allen screw).



Step 4

- Reset the protection plug.



Planetary gearboxes RG

RG05

Gearbox selection

RG	i	T _{2acc} [Nm]	T _{2ISO} [Nm]	T _{2max} [Nm]	n ₁ [min ⁻¹]	n _{1max} [min ⁻¹]	φ [arcmin]	C _t [Nm/arcmin]	F _{r2} [N]	F _{a2} [N]	J ₁ [kgcm ²]	η %	P [kg]	
051	3	12	6	24	3500	5000	< 8	0,9	650	700	0,12	97	0,8	
	1	4	18	8	35	3500	5000	< 8	0,9	650	700	0,12	97	0,8
		5	20	9	40	4000	6000	< 8	0,9	650	700	0,12	97	0,8
		7	23	10	46	4000	6000	< 8	0,9	650	700	0,10	97	0,8
		9	18	8	35	4000	6000	< 8	0,9	650	700	0,10	97	0,8
		10	25	11	52	4000	6000	< 8	0,9	650	700	0,10	97	0,8
052	12	12	6	24	3500	5000	< 12	0,8	650	700	0,10	95	1,0	
	2	15	12	6	24	4000	6000	< 12	0,8	650	700	0,10	95	1,0
		16	18	8	35	3500	5000	< 12	0,8	650	700	0,10	95	1,0
		20	18	8	35	4000	6000	< 12	0,8	650	700	0,10	95	1,0
		25	20	9	40	4000	6000	< 12	0,8	650	700	0,10	95	1,0
		28	18	8	35	4000	6000	< 12	0,8	650	700	0,10	95	1,0
		30	12	6	24	4000	6000	< 12	0,8	650	700	0,10	95	1,0
		35	20	9	40	4000	6000	< 12	0,8	650	700	0,10	95	1,0
		40	18	8	35	4000	6000	< 12	0,8	650	700	0,10	95	1,0
		45	18	8	35	4000	6000	< 12	0,8	650	700	0,10	95	1,0
		50	20	9	40	4000	6000	< 12	0,8	650	700	0,10	95	1,0
		63	18	8	35	4000	6000	< 12	0,8	650	700	0,10	95	1,0
		70	23	10	46	4000	6000	< 12	0,8	650	700	0,10	95	1,0
		81	18	8	35	4000	6000	< 12	0,8	650	700	0,10	95	1,0
		90	18	8	35	4000	6000	< 12	0,8	650	700	0,10	95	1,0
100	25	11	52	4000	6000	< 12	0,8	650	700	0,10	95	1,0		

i	Reduction ratio (finite values)	C ₁	Torsional stiffness
T _{2 acc}	Max. acceleration torque (S5 intermittent operation - max. 1000 cycles/hr)	F _{r2}	Radial load (OHL)
T _{2 ISO}	Nominal torque according to ISO 6336 (S1 continuous operation)	F _{a2}	Axial load
T _{2 max}	Emergency torque (max. 1000 times in gearbox life)	J ₁	Moment of inertia at input
n ₁	Input speed	h	Efficiency
n _{1 max}	Max. input speed	P	Weight (average reduction ratio)
j	Angular backlash	1 ... 2	Gearbox stage number

RG05

Planetary gearboxes RG

Gearbox selection

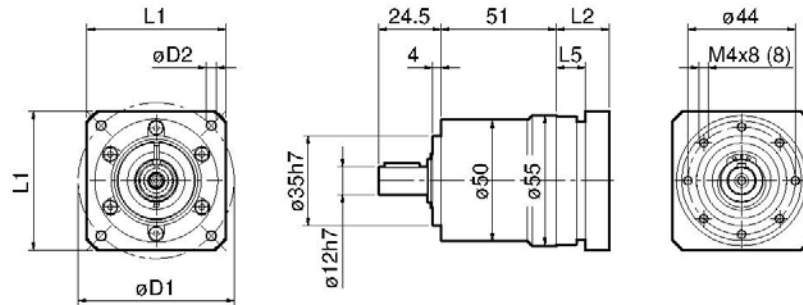

RG051

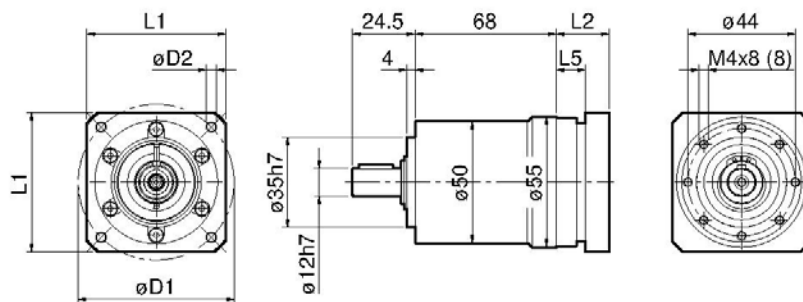
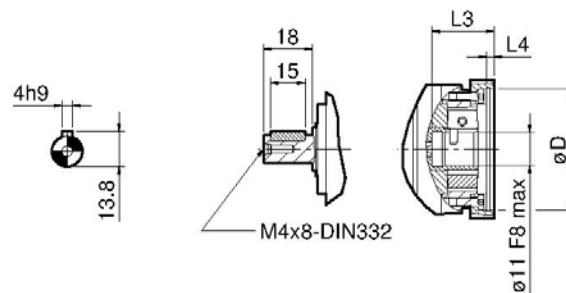

RG052

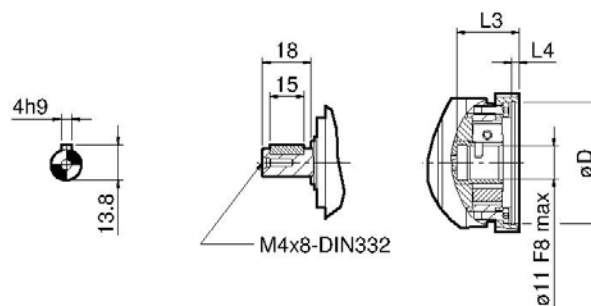

RG	051 / 052	051 / 052	051 / 052	051 / 052	051 / 052			
IEC	---	56 B5	56 B14	63 B5	63 B14			
L ₁	□ 70 x 70	Ø 120	Ø 80	Ø 140	Ø 90			
L ₂	21	27	27	27	27			
L ₃	24	30	30	30	30			
L ₄	4	4	4	4	4			
L ₅	---	14	14	14	14			
ø D	Ø 60 (D8)	Ø 80 (E8)	Ø 50 (E8)	Ø 95 (E8)	Ø 60 (E8)			
ø D ₁	Ø 75	Ø 100	Ø 65	Ø 115	Ø 75			
ø D ₂	M.4 (4)	7	6	10	6			

Planetary gearboxes RG

RG07

Gearbox selection

RG	i	T _{2acc} [Nm]	T _{2ISO} [Nm]	T _{2max} [Nm]	n ₁ [min ⁻¹]	n _{1max} [min ⁻¹]	φ [arcmin]	C _t [Nm/arcmin]	F _{r2} [N]	F _{a2} [N]	J ₁ [kgcm ²]	η %	P [kg]	
071	3	37	17	70	3500	5000	< 8	3,4	1450	1550	0,35	97	1,8	
	1	4	53	25	100	3500	5000	< 8	3,4	1450	1550	0,35	97	1,8
		5	60	26	115	3700	6000	< 8	3,4	1450	1550	0,35	97	1,8
		7	69	32	135	3700	6000	< 8	3,4	1450	1550	0,30	97	1,8
		9	55	25	110	3700	6000	< 8	3,4	1450	1550	0,30	97	1,8
		10	76	35	150	3700	6000	< 8	3,4	1450	1550	0,30	97	1,8
072	12	37	17	70	3500	5000	< 12	2,9	1450	1550	0,30	95	2,2	
	2	15	37	17	70	3700	6000	< 12	2,9	1450	1550	0,30	95	2,2
		16	53	25	100	3500	5000	< 12	2,9	1450	1550	0,30	95	2,2
		20	53	25	100	3700	6000	< 12	2,9	1450	1550	0,30	95	2,2
		25	60	26	115	3700	6000	< 12	2,9	1450	1550	0,30	95	2,2
		28	53	25	100	3700	6000	< 12	2,9	1450	1550	0,30	95	2,2
		30	35	17	70	3700	6000	< 12	2,9	1450	1550	0,30	95	2,2
		35	60	26	115	3700	6000	< 12	2,9	1450	1550	0,30	95	2,2
		40	53	25	100	3700	6000	< 12	2,9	1450	1550	0,30	95	2,2
		45	55	25	110	3700	6000	< 12	2,9	1450	1550	0,30	95	2,2
		50	60	26	115	3700	6000	< 12	2,9	1450	1550	0,30	95	2,2
		63	55	25	110	3700	6000	< 12	2,9	1450	1550	0,30	95	2,2
		70	69	32	135	3700	6000	< 12	2,9	1450	1550	0,30	95	2,2
		81	55	25	110	3700	6000	< 12	2,9	1450	1550	0,30	95	2,2
	90	55	25	110	3700	6000	< 12	2,9	1450	1550	0,30	95	2,2	
	100	76	35	150	3700	6000	< 12	2,9	1450	1550	0,30	95	2,2	

i	Reduction ratio (finite values)	C ₁	Torsional stiffness
T _{2acc}	Max. acceleration torque (S5 intermittent operation - max. 1000 cycles/hr)	F _{r2}	Radial load (OHL)
T _{2ISO}	Nominal torque according to ISO 6336 (S1 continuous operation)	F _{a2}	Axial load
T _{2max}	Emergency torque (max. 1000 times in gearbox life)	J ₁	Moment of inertia at input
n ₁	Input speed	h	Efficiency
n _{1max}	Max. input speed	P	Weight (average reduction ratio)
j	Angular backlash	1 ... 2	Gearbox stage number

RG07

Planetary gearboxes RG

Gearbox selection

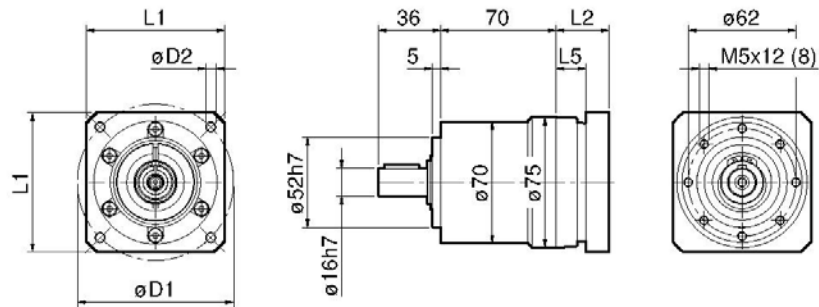

RG071

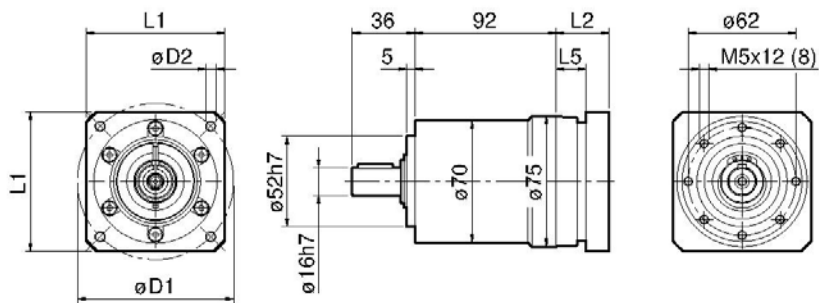
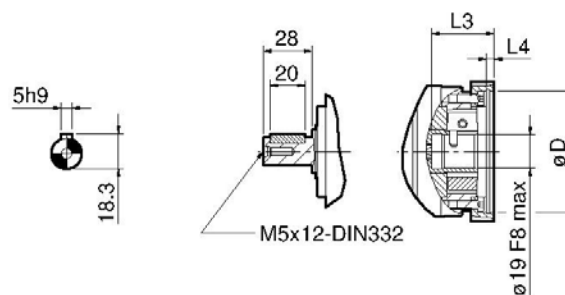

RG072

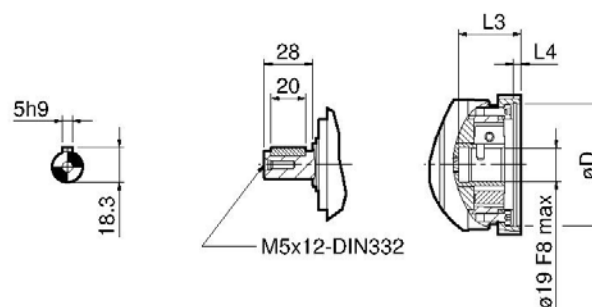

RG	071 / 072	071 / 072	071 / 072	071 / 072	071 / 072	071 / 072	071 / 072	071 / 072
IEC	---	56 B5	56 B14	63 B5	63 B14	71 B5	71 B14	80 B14
L ₁	□ 85 x 85	Ø 120	Ø 80	Ø 140	Ø 90	Ø 160	Ø 105	Ø 120
L ₂	25	29.5	29.5	28.5	29.5	29.5	29.5	38.5
L ₃	30	35.5	35.5	35.5	35.5	35.5	35.5	44.5
L ₄	4,5	4	3	4	4	4	4	4
L ₅	---	16.5	16.5	16.5	16.5	16.5	16.5	25.5
ø D	Ø 80 (D8)	Ø 80 (E8)	Ø 50 (E8)	Ø 95 (E8)	Ø 60 (E8)	Ø 110 (E8)	Ø 70 (E8)	Ø 80 (E8)
ø D ₁	Ø 100	Ø 100	Ø 65	Ø 115	Ø 75	Ø 130	Ø 85	Ø 100
ø D ₂	M6 (4)	7	6	10	6	10	7	7

Planetary gearboxes RG

RG09

Gearbox selection

RG	i	T _{2acc} [Nm]	T _{2ISO} [Nm]	T _{2max} [Nm]	n ₁ [min ⁻¹]	n _{1max} [min ⁻¹]	φ [arcmin]	C ₁ [Nm/arcmin]	F _{r2} [N]	F _{a2} [N]	J ₁ [kgcm ²]	η %	P [kg]	
091	3	95	45	185	3000	4500	< 8	9,3	2400	1900	1,85	97	4,0	
	1	4	140	68	260	3000	4500	< 8	9,3	2400	1900	1,85	97	4,0
		5	160	75	300	3400	5500	< 8	9,3	2400	1900	1,85	97	4,0
		7	180	89	350	3400	5500	< 8	9,3	2400	1900	1,80	97	4,0
		9	145	70	280	3400	5500	< 8	9,3	2400	1900	1,80	97	4,0
		10	200	98	390	3400	5500	< 8	9,3	2400	1900	1,80	97	4,0
092	12	95	45	185	3000	4500	< 12	7,6	2400	1900	1,80	95	4,9	
	2	15	95	45	185	3400	5500	< 12	7,6	2400	1900	1,80	95	4,9
		16	140	68	260	3000	4500	< 12	7,6	2400	1900	1,80	95	4,9
		20	140	68	260	3400	5500	< 12	7,6	2400	1900	1,80	95	4,9
		25	160	75	300	3400	5500	< 12	7,6	2400	1900	1,80	95	4,9
		28	140	68	260	3400	5500	< 12	7,6	2400	1900	1,80	95	4,9
		30	95	45	185	3400	5500	< 12	7,6	2400	1900	1,80	95	4,9
		35	160	75	300	3400	5500	< 12	7,6	2400	1900	1,80	95	4,9
		40	140	68	260	3400	5500	< 12	7,6	2400	1900	1,80	95	4,9
		45	145	70	280	3400	5500	< 12	7,6	2400	1900	1,80	95	4,9
		50	160	75	300	3400	5500	< 12	7,6	2400	1900	1,80	95	4,9
		63	145	70	280	3400	5500	< 12	7,6	2400	1900	1,80	95	4,9
		70	180	89	350	3400	5500	< 12	7,6	2400	1900	1,80	95	4,9
		81	145	70	280	3400	5500	< 12	7,6	2400	1900	1,80	95	4,9
		90	145	70	280	3400	5500	< 12	7,6	2400	1900	1,80	95	4,9
100	200	98	390	3400	5500	< 12	7,6	2400	1900	1,80	95	4,9		

i	Reduction ratio (finite values)	C ₁	Torsional stiffness
T _{2acc}	Max. acceleration torque (S5 intermittent operation - max. 1000 cycles/hr)	F _{r2}	Radial load (OHL)
T _{2ISO}	Nominal torque according to ISO 6336 (S1 continuous operation)	F _{a2}	Axial load
T _{2max}	Emergency torque (max. 1000 times in gearbox life)	J ₁	Moment of inertia at input
n ₁	Input speed	h	Efficiency
n _{1max}	Max. input speed	P	Weight (average reduction ratio)
j	Angular backlash	1 ... 2	Gearbox stage number

RG09

Planetary gearboxes RG

Gearbox selection

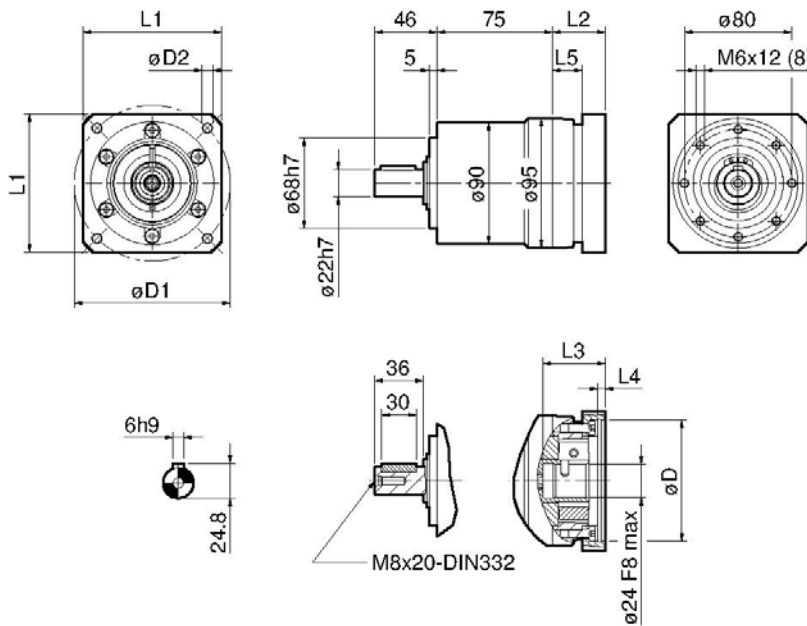

RG091

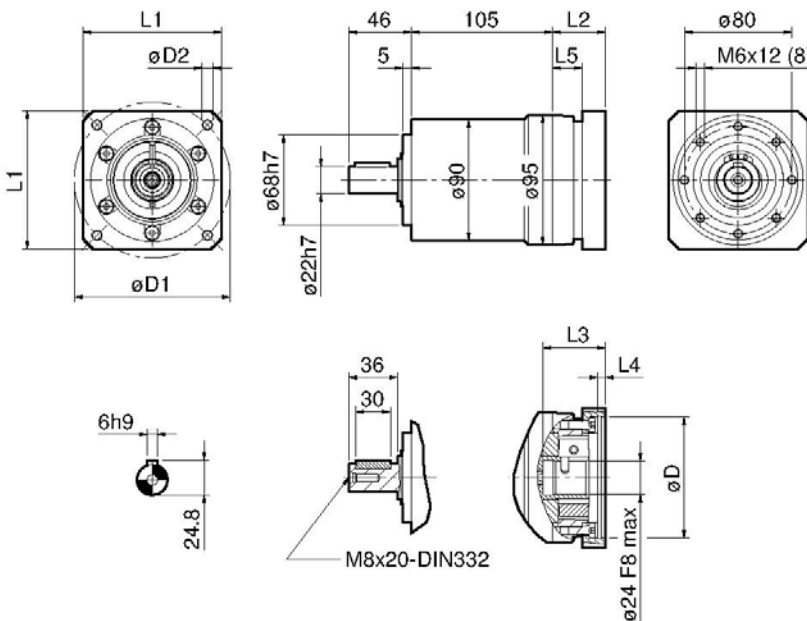

RG092

RG	091 / 092	091 / 092	091 / 092	091 / 092	091 / 092	091 / 092	091 / 092	091 / 092	091 / 092
IEC	---	56 B5	63 B5	71 B5	71 B14	80 B5	80 B14	90 B5	90 B14
L ₁	□ 120 x 120	Ø 120	Ø 140	Ø 160	Ø 105	Ø 200	Ø 120	Ø 200	Ø 140
L ₂	50	40	40	40	41.5	40	40	64	64
L ₃	38	41.5	41.5	41.5	43	41.5	41.5	65.5	65.5
L ₄	4,5	4	4	4	4	4	4	4	4
L ₅	---	26	26	26	26	26	26	50	50
ø D	Ø 110 (D8)	Ø 80 (E8)	Ø 95 (E8)	Ø 110 (E8)	Ø 70 (E8)	Ø 130 (E8)	Ø 80 (E8)	Ø 130 (E8)	Ø 95 (E8)
ø D ₁	Ø 130	Ø 100	Ø 115	Ø 130	Ø 85	Ø 165	Ø 100	Ø 165	Ø 115
ø D ₂	M8 (4)	7	10	10	7	12	7	12	10

Planetary gearboxes RG

RG12

Gearbox selection

RG	i	T _{2acc} [Nm]	T _{2ISO} [Nm]	T _{2max} [Nm]	n ₁ [min ⁻¹]	n _{1max} [min ⁻¹]	φ [arcmin]	C _t [Nm/arcmin]	F _{r2} [N]	F _{a2} [N]	J ₁ [kgcm ²]	η %	P [kg]
121	3	230	110	430	2500	4000	< 8	25	4600	4000	5,60	97	9,0
	4	330	160	600	2500	4000	< 8	25	4600	4000	5,60	97	9,0
	5	380	180	700	2600	4800	< 8	25	4600	4000	5,60	97	9,0
	7	430	210	800	2600	4800	< 8	25	4600	4000	5,55	97	9,0
	9	350	160	650	2600	4800	< 8	25	4600	4000	5,55	97	9,0
	10	480	230	900	2600	4800	< 8	25	4600	4000	5,55	97	9,0
122	12	230	110	430	2500	4000	< 12	21	4600	4000	5,55	95	11
	15	230	110	430	2600	4800	< 12	21	4600	4000	5,55	95	11
	16	330	160	600	2500	4000	< 12	21	4600	4000	5,55	95	11
	20	330	160	600	2600	4800	< 12	21	4600	4000	5,55	95	11
	25	380	180	700	2600	4800	< 12	21	4600	4000	5,55	95	11
	28	330	160	600	2600	4800	< 12	21	4600	4000	5,55	95	11
	30	230	110	430	2600	4800	< 12	21	4600	4000	5,55	95	11
	35	380	180	700	2600	4800	< 12	21	4600	4000	5,55	95	11
	40	330	160	600	2600	4800	< 12	21	4600	4000	5,55	95	11
	45	350	160	650	2600	4800	< 12	21	4600	4000	5,55	95	11
	50	380	180	700	2600	4800	< 12	21	4600	4000	5,55	95	11
	63	350	160	650	2600	4800	< 12	21	4600	4000	5,55	95	11
	70	430	210	800	2600	4800	< 12	21	4600	4000	5,55	95	11
	81	350	160	350	2600	4800	< 12	21	4600	4000	5,55	95	11
90	350	160	650	2600	4800	< 12	21	4600	4000	5,55	95	11	
100	480	230	900	2600	4800	< 12	21	4600	4000	5,55	95	11	

i	Reduction ratio (finite values)	C ₁	Torsional stiffness
T _{2 acc}	Max. acceleration torque (S5 intermittent operation - max. 1000 cycles/hr)	F _{r2}	Radial load (OHL)
T _{2 ISO}	Nominal torque according to ISO 6336 (S1 continuous operation)	F _{a2}	Axial load
T _{2 max}	Emergency torque (max. 1000 times in gearbox life)	J ₁	Moment of inertia at input
n ₁	Input speed	h	Efficiency
n _{1 max}	Max. input speed	P	Weight (average reduction ratio)
j	Angular backlash	1 ... 2	Gearbox stage number

RG12

Planetary gearboxes RG

Gearbox selection

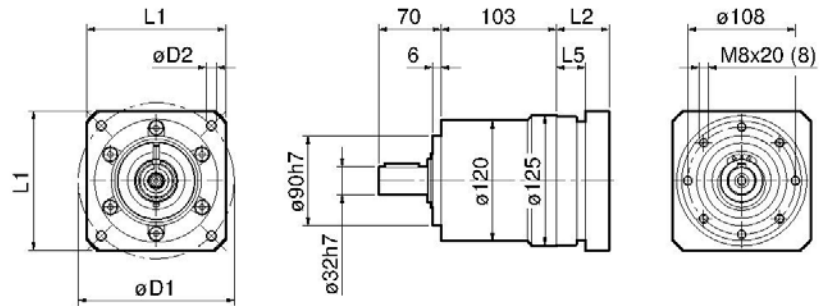

RG121

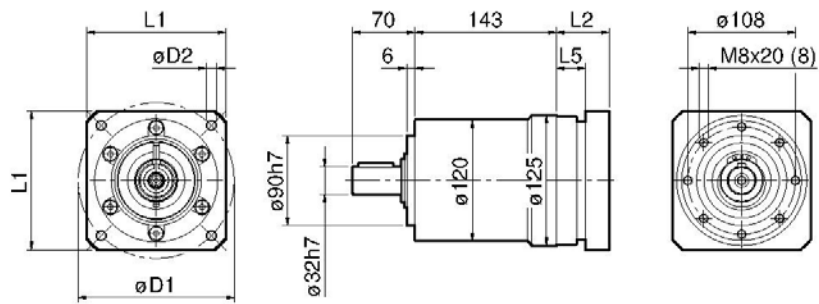
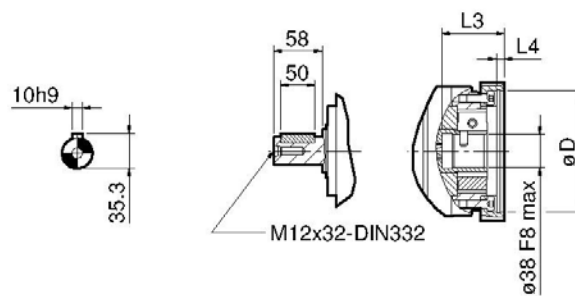

RG122

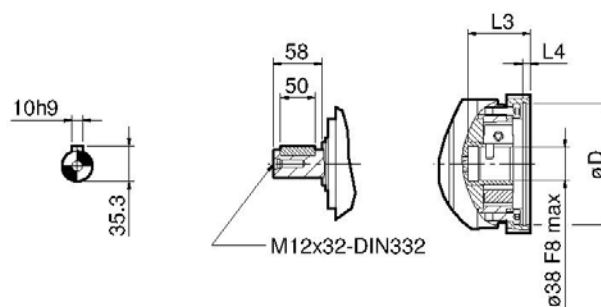

RG	121 / 122	121 / 122	121 / 122	121 / 122	121 / 122	121 / 122	121 / 122	121 / 122
IEC	---	71 B5	80 B5	90 B5	100/112 B5	100/112 B14	132 B5	132 B14
L ₁	□ 158 x 158	Ø 160	Ø 200	Ø 200	Ø 250	Ø 160	Ø 300	Ø 200
L ₂	58	51.5	49.5	49.5	79.2	80.5	78.5	78.5
L ₃	52,5	54	52	52	81.7	83	81	81
L ₄	4,5	4,5	5	5	5	4,5	5	5
L ₅	---	31.5	31.5	31.5	60.5	60.5	60.5	60.5
ø D	Ø 130 (D8)	Ø 110 (E8)	Ø 130 (E8)	Ø 130 (E8)	Ø 180 (E8)	Ø 110 (E8)	Ø 230 (E8)	Ø 130 (E8)
ø D ₁	Ø 165	Ø 130	Ø 165	Ø 165	Ø 215	Ø 130	Ø 260	Ø 165
ø D ₂	M10 (4)	10	7	12	14	11	M12 (4)	12

Planetary gearboxes RG

Abstract of OPERATION AND MAINTENANCE INSTRUCTIONS

(complete manual on www.varvel.com)

Variable speed and reduction gearboxes are not part of the field of application of the Machinery Directive, art.1(2), and they must not be put into service until the machinery into which they are to be incorporated, has been declared in conformity with the provision of art. 4(2), annex II(B) of Machinery Directives 98/37/CEE/22.6.98 and for Italy only, of DL 459/24.7.96.

Installation

Check if the unit to be installed, is properly selected to perform the required function and that its mounting position complies with the order.

The nameplate reports such information.

Check mounting stability to ensure the unit runs without vibrations or overloads.

Running

The unit may be connected for clockwise or counter-clockwise rotation.

The unit must be stopped as soon as defective running or unexpected noise occur, remove the faulty part or return the unit to the factory for checking.

If the faulty part is not replaced, other parts can also be affected, causing more severe damage and making the identification of initial cause more difficult.

Maintenance

Although the units are no-load run tested in the factory before despatch, it is recommended not to run them at maximum load for the first 20-30 running hours to allow the proper running in.

The gearboxes are delivered already filled with long-life synthetic oil and, in case of replacement or topping, do not mix with mineral lubricants.

Handling

When hoisting, use relevant housing locations or eyebolts if provided, or foot or flange holes.

Never hoist on any moving part.

Painting

Carefully protect oil seals, coupling faces and shafts when units are re-painted.

Long-term storage

For storage longer than 3 months, apply anti-oxidants onto shafts and machined surfaces, and protective grease on oil seal lips.

Product's Environmental Management

In conformity with Environmental Certification ISO 14001, we recommend the following to dispose of our products:

- scraped components of the units to be delivered to authorized centres for metal object collection;
- oils and lubricants drained from the units to be delivered to Exhausted Oil Unions;
- packages (pallets, carton boxes, paper, plastic, etc.) to lead into regeneration/recycling circuits as far as possible, by delivering separate waste classes to authorized companies.



unicef



A socially responsible company

To the scope of intensifying our commitment to society, Varvel since 2004 started an ongoing support programme with three non-profit institutions: UNICEF (United Nations Children's Fund), MSF (Médecins sans Frontières) and ANT (National Cancer Association). Environmental respect and protection are also part of Varvel's values and this is why Varvel certified in 2001 its Environmental System to standard UNI EN ISO 14001.

DISTRIBUTED BY



CHAIN & DRIVES
COMPLETE BEARINGS
& POWER TRANSMISSION

SERVICE & SUPPORT

Wangara, WA Welshpool, WA Arndell Park, NSW
+61 8 9303 4966 +61 8 6314 1155 +61 2 9674 8611
support@chainanddrives.com.au salesnsw@chainanddrives.com.au

chainanddrives.com.au