

3015

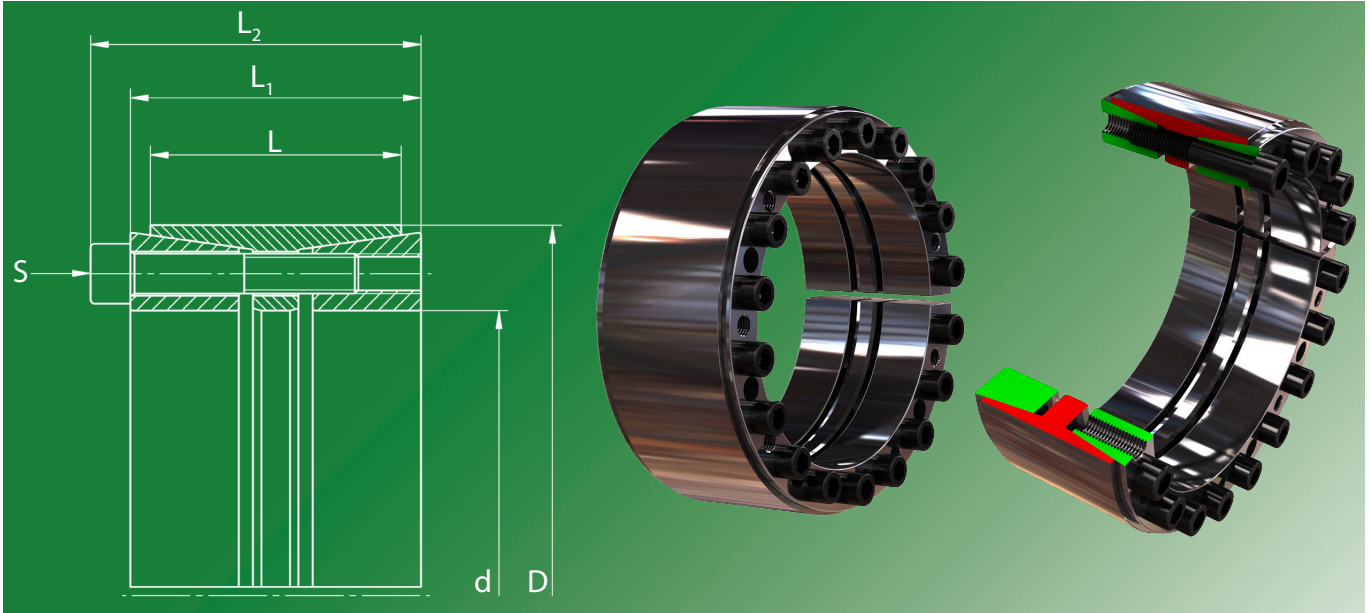

Used symbols

d	[mm]	Shaft diameter	
D	[mm]	Hub inside diameter	
M_t	[Nm]	Max. transmittable torque	$F_{ax} = 0$
F_{ax}	[kN]	Max. transmittable axial force	$M_t = 0$
p_w	[N/mm ²]	Average pressure on the shaft	
p_n	[N/mm ²]	Average pressure on the hub	
L	[mm]	Length of the sleeve	
L_1	[mm]	Width of the locking device without screws	
L_2	[mm]	Width of the locking device with screws	
Z		Number of clamping screws	
S		Size of the clamping screws	
M_A	[Nm]	Tightening torque of the clamping screws	

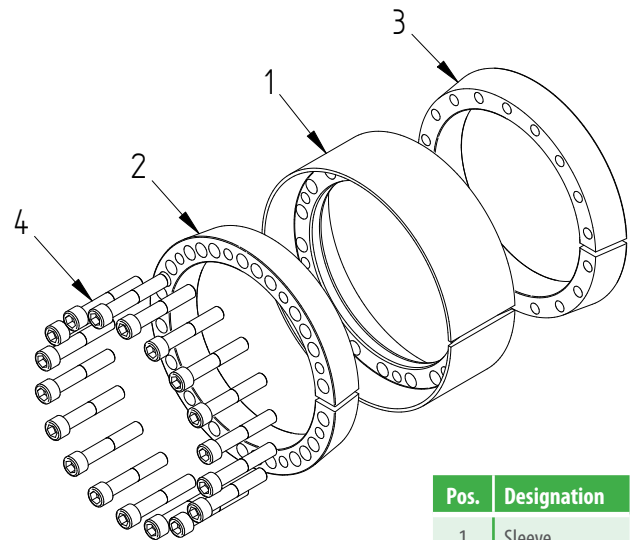

Pos.	Designation
1	Sleeve
2	Pressure ring 1
3	Pressure ring 2
4	Screw

Recommended tolerances & surfaces

Shaft	h8 / Rz10
Hub	H8 / Rz10

Bending loads

Bending moment (share)	$M_B \max = 0,3 * M_t$
Bending angle	max. 5°

More properties

- low axial displacement during assembly
- good self-centering
- low self-locking

Ordering information: TAS 3015/d/D (for example: TAS 3015/150/200 ... further sizes on request)

d mm	D mm	M_t Nm	F_{ax} kN	P_w N/mm ²	P_N N/mm ²	Z Stk	S	M_A Nm	L mm	L₁ mm	L₂ mm	Weight kg
70	x 110	6900	197	187	95	8	M10 x 055	83	50	60	70	2,2
80	x 120	9800	247	204	109	10	M10 x 055	83	50	60	70	2,5
90	x 130	12200	271	200	111	11	M10 x 055	83	50	60	70	2,7
100	x 145	18200	364	201	111	10	M12 x 060	145	60	70	82	4,1
110	x 155	20000	364	183	104	10	M12 x 060	145	60	70	82	4,4
120	x 165	24000	401	185	107	11	M12 x 060	145	60	70	82	4,7
130	x 180	33100	510	193	116	14	M12 x 065	145	65	79	91	6,2
140	x 190	38200	547	192	117	15	M12 x 065	145	65	79	91	6,6
150	x 200	40900	547	179	112	15	M12 x 065	145	65	79	91	7,0
160	x 210	46600	583	179	113	16	M12 x 065	145	65	79	91	7,4
170	x 225	62300	734	179	111	15	M14 x 075	230	78	92	106	10,4
180	x 235	66000	734	169	106	15	M14 x 075	230	78	92	106	11,0
190	x 250	74300	782	144	94	16	M14 x 080	230	88	102	116	14,3
200	x 260	97100	972	170	113	18	M14 x 080	230	88	102	116	15,0
220	x 285	110000	1007	148	98	15	M16 x 090	355	96	108	124	19,4
240	x 305	161000	1342	181	122	20	M16 x 090	355	96	108	124	21,0
260	x 325	174000	1342	167	114	20	M16 x 090	355	96	108	124	22,5
280	x 355	219000	1569	196	122	15	M20 x 100	690	96	110	130	28,2
300	x 375	251000	1674	195	123	16	M20 x 100	690	96	110	130	30,0
320	x 405	334000	2092	181	111	20	M20 x 110	690	124	136	156	47,1
340	x 425	355000	2092	170	105	20	M20 x 110	690	124	136	156	49,7
360	x 455	469000	2610	160	109	20	M22 x 130	930	140	157	179	66,8
380	x 475	495000	2610	152	104	20	M22 x 130	930	140	157	179	70,1
400	x 495	574000	2871	159	110	22	M22 x 130	930	140	157	179	73,4
420	x 515	657000	3132	165	115	24	M22 x 130	930	140	157	179	76,7
440	x 535	689000	3132	157	111	24	M22 x 130	930	140	157	179	79,9
460	x 555	720000	3132	151	107	24	M22 x 130	930	140	157	179	83,2
480	x 575	782000	3262	150	108	25	M22 x 130	930	140	157	179	86,5
500	x 595	815000	3262	144	104	25	M22 x 130	930	140	157	179	89,8
520	x 615	950000	3654	155	113	28	M22 x 130	930	140	157	179	93,1
540	x 635	986000	3654	150	109	28	M22 x 130	930	140	157	179	96,3
560	x 655	1096000	3915	155	113	30	M22 x 130	930	140	157	179	100
580	x 675	1135000	3915	149	110	30	M22 x 130	930	140	157	179	103
600	x 695	1174000	3915	144	107	30	M22 x 130	930	140	157	179	106

DISTRIBUTED BY



SERVICE & SUPPORT

Wangara, WA **Welshpool, WA** **Arndell Park, NSW**
+61 8 9303 4966 **+61 8 6314 1155** **+61 2 9674 8611**
support@chainanddrives.com.au salesnsw@chainanddrives.com.au

chainanddrives.com.au