

Mönninghoff

Electromagnetic pole-face friction clutch Type 450

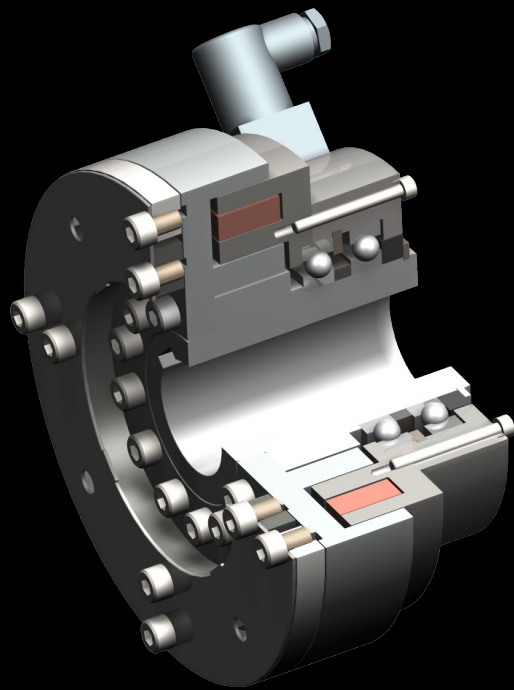

CHAIN & DRIVES
COMPLETE BEARINGS
& POWER TRANSMISSION

POWER > SPEED > TORQUE

Electromagnetic pole-face friction clutch - Type 450

Characteristics and features

- suitable for torque transmission with increasing differential speed between the drive elements
- high torque transfer despite compact dimensions
- designs up to 8200 Nm possible
- large bore due to the double magnetomotive force of the armature disk possible
- backlash-free torque transmission by integrated diaphragm spring
- rapid disengagement of clutch halves after switch-off without residual torque
- high switching frequency due to optimized heat dissipation
- zero-maintenance due to power supply without slip rings and permanently-lubricated bearings prestressed in order to avoid slide wear
- excellent friction and wear characteristics by special treatment of friction surfaces
- oil running or dry running
- suitable for applications in harsh environments
- reduced shift speeds due to adapted control
- also available as pole face friction brake type 460 / 465



Mönninghoff power transmission represents an infinite variant diversity that is applied by all areas of modern mechanical engineering.

Our technologies are mostly designed to operate under extreme conditions. We offer high precision products for medical robotics, fail-proof security for aerospace technology or synchronization solutions for the packaging or printing industry.

We thus address customers who have the highest standards for their own machines or systems. To them, we can offer highly complex, application-specific solutions.

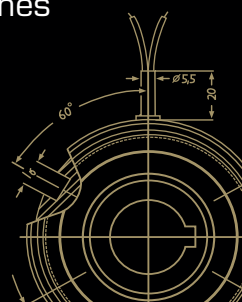

Electromagnetic pole-face friction clutch - Type 450

Match code

Mönninghoff pole face friction clutches are indicated by the following match code:

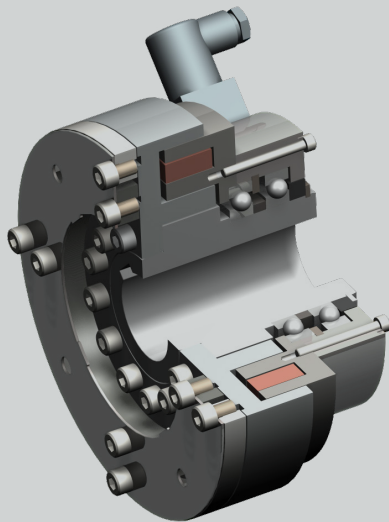

450 . A . B

A clutch size

B design of stator

Other individual characteristics:

- voltage
- bore size with keyway

According to these characteristics, we design individual solutions concerning transmitted torque, engaging behavior or rotation speed.

Our engineers can assist with finding an application-specific clutch at any time. Together, we can develop individual and innovative solutions for extreme operating conditions.

Ordering example

Mönninghoff pole face friction clutch
Type 450.25.4.3

Voltage	24 Vdc
Bore size d	40mm H7, keyway acc. to DIN 6885/1

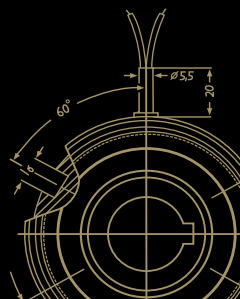

Electromagnetic pole-face friction clutch - Type 450

Clutch size - torque calculations

When dimensioning a Mönninghoff pole face friction clutch, several technical preconditions should be considered:

- The condition for accelerating the clutch output end in the predefined time and transmitting the load torque is as follows (torque applied to the output of the engaged clutch by the driven machine).

$$M_a + M_L \leq \frac{M_K + M_S (\Delta n)}{2}$$

$$M_a = \frac{J_L \cdot \Delta n}{9,55 \cdot t_3}$$

$$\Delta n = n_1 - n_2$$

- t_3 must be ≤ 1 s in order to avoid thermal overload of the friction surfaces.
- The load torque also has to be transmitted reliably between the clutch input and output ends at the initial relative speed:

$$M_L \leq M_S (\Delta n)$$

- The switching torque M_S (effective torque in the shaft train of a slipping clutch) is dependent upon the relative speed Δn of the clutch halves in accordance with the characteristic illustrated on the following page.
- Including transient overloads (torque surges), the load torque must not exceed the transmissible torque of the clutch:

$$M_L \cdot cs \leq M_{\bar{U}}$$

M_a = acceleration torque

M_L = load torque

M_K = characteristic torque

M_S = switching torque

$M_{\bar{U}}$ = transmissible torque

cs = 1,2...4, surge factor in acc.
with operating conditions

J_L = moment of inertia of all output
components [kg · m²]

n_1 = input speed [min⁻¹]

n_2 = output speed [min⁻¹]

t_3 = acceleration time [s]

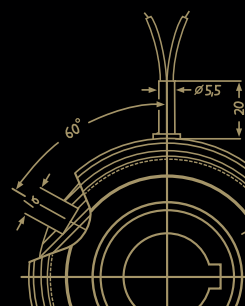

Electromagnetic pole-face friction clutch - Type 450

Clutch size - torque calculations

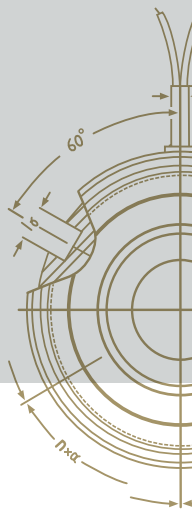
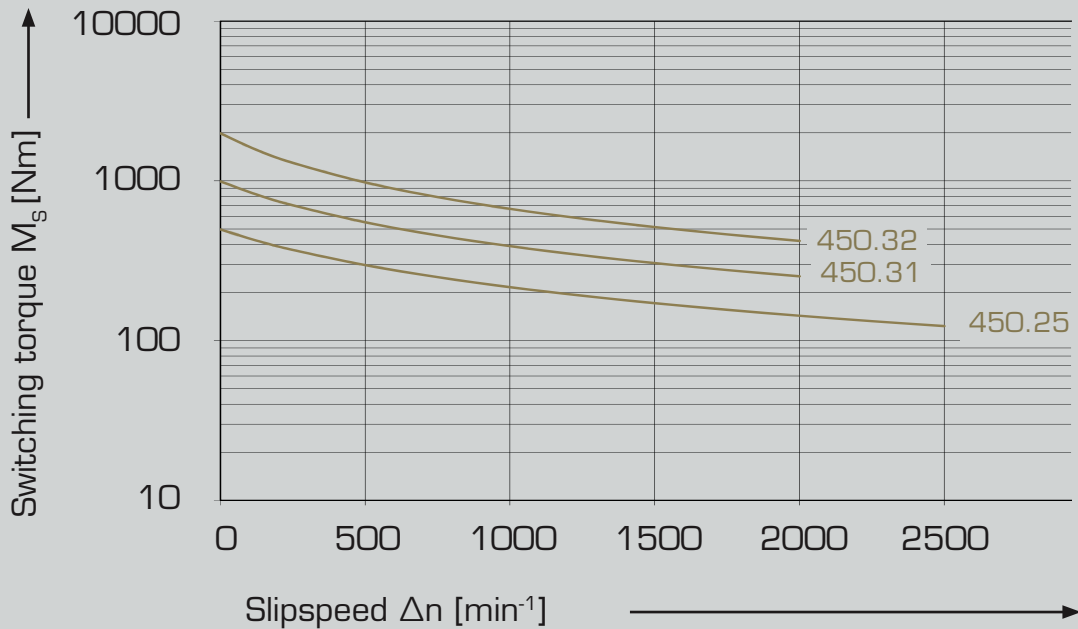

Clutch size - calculation of dissipated energy

Whilst the clutch is slipping at the start of the switching operation, the dissipated energy generated is converted into heat. To avoid the clutch overheating, at a switching frequency of S_h switching operations per hour, the dissipated energy Q must not exceed the permissible dissipated energy Q_{zul} . The dissipated energy to be absorbed by the clutch per switching operations is calculated as follows:

$$Q = \frac{M_K \cdot J_L (\Delta n \cdot \pi / 30)^2}{2000 (M_K - M_L)} \text{ in kJ}$$

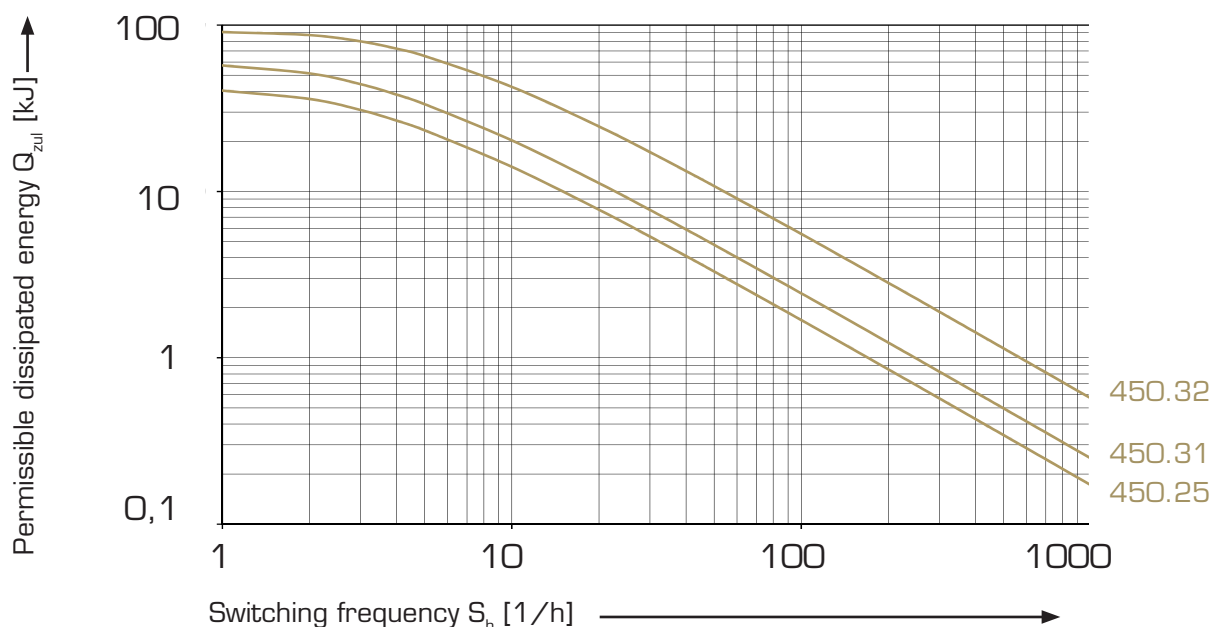

Electromagnetic pole-face friction clutch - Type 450

Design 1 - flange mounted design

- depending on the application, our designers can offer further versions up to 8200 Nm
- also the types 2 (flange mounted with plug and socked) and 3 (bearing mounted with flying leads) are possible as special versions

Technical data of flange mounted types

Size			25	31	32
transmissible torque	M_t	[Nm]	500	1000	2000
rated torque	M_k	[Nm]	400	800	1600
max. speed	n_{max}	[min ⁻¹]	6000	5000	4000
input power	P_{20}	[W]	97	136	171
inertia	armature	J_A	13,66	43,95	103,08
	rotor	J_R	25,66	73,98	223,32
weight	m_{ges}	[kg]	11,5	21,1	37,5
dimensions	D	[mm]	200	250	315
	D ₁		230	285	350
	d ₁ H7		112	143	190
	d ₂		160	205	260
	d ₂		4 x 90°	4 x 90°	6 x 60°
	d ₃		9,2	11,2	11,2
	d ₄		15	18	18
	d ₅		135	170	230
	d ₅		4 x 90°	4 x 90°	6 x 60°
	d ₆		180	230	290
	d ₆		4 x 90°	4 x 90°	6 x 60°
	d ₇		13	16	16
	d ₈		85	113	134
	d ₈		12 x 30°	12 x 30°	12 x 30°
	d ₁₀ H7		68	95	110
	d ₁₁		99,5	127	155
	d ₁₂		100	130	167
	d ₁₃		115	150	180
	d ₁₄		215	270	335
	d ₁₄		4 x 90°	4 x 90°	4 x 90°
d ₁₅		9	9	9	
d ₁₆		9	9	11	
L ₁		67,9	81,4	88,9	
L ₂		50,9	61,4	68,9	
l ₁		12	15	18	
l ₂		42	48	57	
l ₃		4,7	4,5	5,5	
l ₄		0,4 +0,2	0,4 +0,2	0,4 +0,2	
l ₇		10	14	14	
l ₈		5	6	7	
l ₁₂		8	10	10	

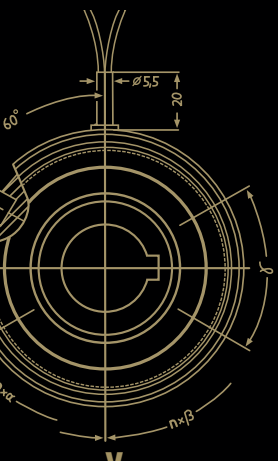
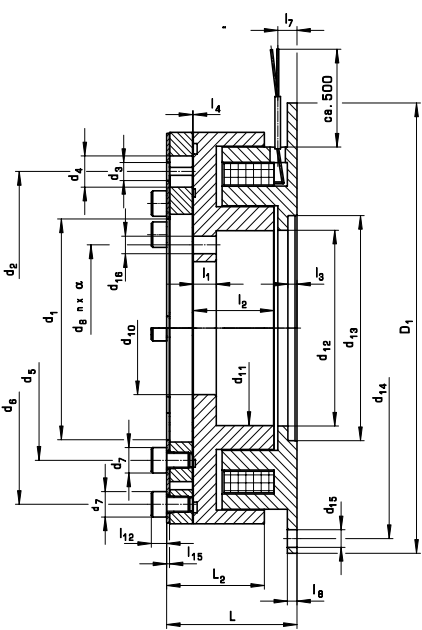

Electromagnetic pole-face friction clutch - Type 450

Design 4 - bearing mounted

- depending on the application, our designers can offer further versions up to 8200 Nm
- also the types 2 (flange mounted with plug and socked) and 3 (bearing mounted with flying leads) are possible as special versions

Technical data of bearing mounted types

Size			25	31	32
transmissible torque	M_t	[Nm]	500	1000	2000
rated torque	M_K	[Nm]	400	800	1600
max. speed	n_{max}	[min ⁻¹]	4000	3200	2600
input power	P_{20}	[W]	97	136	171
inertia	armature	J_A	13,66	43,95	103,08
	rotor	J_R	25,66	73,98	223,32
	hub	J_N	3,66	11,93	26,54
weight	m_{ges}	[kg]	18,8	34,5	60,1
dimensions	D	[mm]	200	250	315
	D ₁		184,8	231,6	291,8
	D ₂		150	190	224
	d ₁ H7		112	143	190
	d ₂		160	205	260
	d ₂	4 x 90°	4 x 90°	4 x 90°	6 x 60°
	d ₃		9,2	11,2	11,2
	d ₄		15	18	18
	d ₅		135	170	230
	d ₅	4 x 90°	4 x 90°	4 x 90°	6 x 60°
	d ₆		180	230	290
	d ₆	4 x 90°	4 x 90°	4 x 90°	6 x 60°
	d ₇		13	16	16
	d ₈		85	113	134
	d ₈	12 x 30°	12 x 30°	12 x 30°	12 x 30°
	d ₉		13	13	16
L		110,9	128,4	145,9	
L ₁		67,9	81,4	88,9	
L ₂		50,9	61,4	68,9	
l		97	110	128	
l ₄		0,4 ^{+0,2}	0,4 ^{+0,2}	0,4 ^{+0,2}	
l ₅		≈ 50	≈ 50	≈ 50	
l ₆		128,5	148	165,5	
l ₉		6	10	10	
l ₁₀		10	12	12	
l ₁₁		8	8	10	
l ₁₂		8	10	10	
l ₁₄		≈ 9	≈ 5	≈ 2	

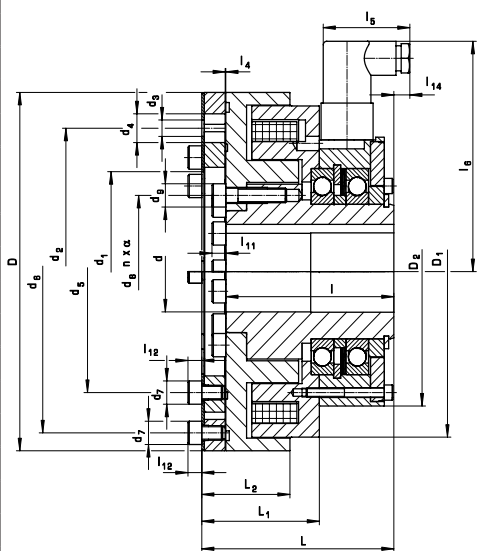

Electromagnetic pole-face friction clutch - Type 450

Voltage

- standard voltage is 24 Vdc direct current
- special voltages as an example 12 or 48 Vdc on request

Technical characteristics

- Energising the coil generates a magnetic flux inside the clutch. This flux exerts an attractive force on the armature rings via the rotor's four pole faces. This force draws the armature towards the front face of the rotor (axial attraction) and non-positive clutch torque transmission takes place.
- When the clutch disengages, the diaphragm spring moves the armature back to its initial position.
- Suitable for both dry and wet running. In wet running, the torques are reduced to approx. 25% of the values indicated.

At a glance

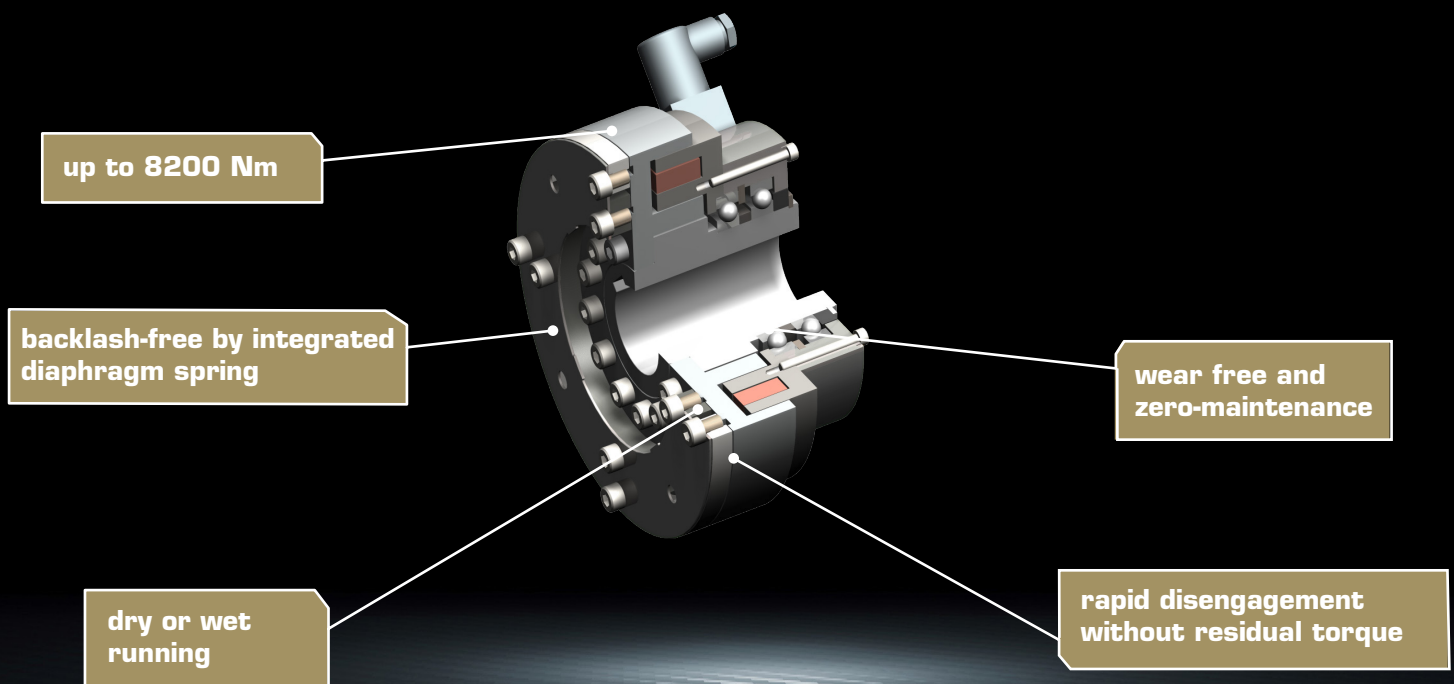

System solutions

You need more?

Mönninghoff clutches can be combined with a variety of many other power transmission elements. Such complex high-tech systems can solve any application-specific tasks and can fulfill any customer-specific wishes.

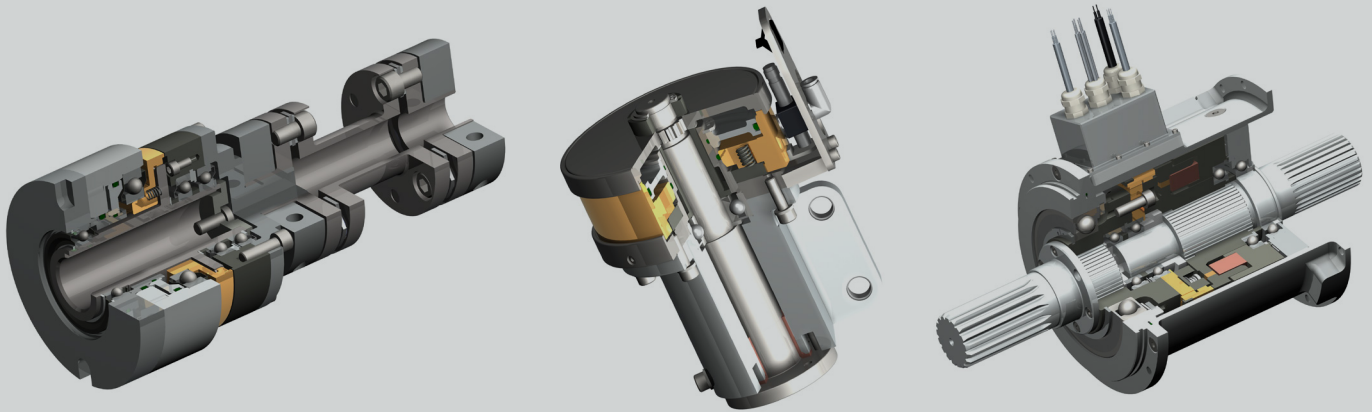

In many cases, a combination of different drive elements is needed to solve the applications particular problems and difficulties. Being not just supplier but technological partner to our customers, our extensive engineering is part of extraordinary and challenging power transmission projects.

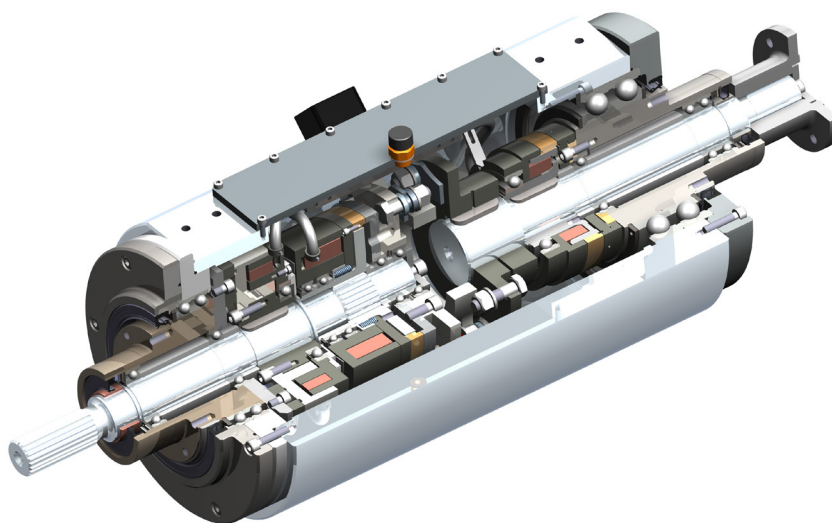

**Our product is the know-how,
with hardware as an added bonus.**

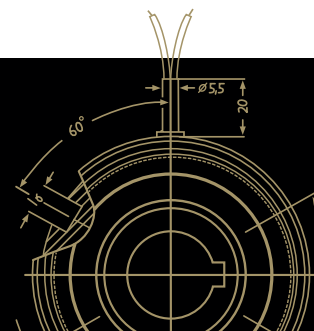

Driven by excellence

Why Mönninghoff

- intensive dialog with our customers' engineers
- decades of experience and competence
- deep understanding for all areas of mechanical engineering
- highly modern and flexible machine park
- enthusiasm for quality
- flexibility, inventiveness and communication skills of our employees
- commitment to Germany and Bochum as industrial location



Helps you find a customer-specific power transmission solution for extraordinary circumstances.



For the competent processing and smooth handling of your orders and delivery dates.



Feels committed to protect and preserve the high value of your machine and to secure its availability.



WA LOCATIONS

Unit 1 / 45 Inspiration Drive, Wangara WA 6065
(08) 9303 4966

Unit 16 / 51-53 Kewdale Road, Welshpool WA 6106
(08) 6314 1155

support@chainanddrives.com.au

NSW LOCATION

Unit 7 / 70 Holbeche Road, Arndell Park NSW 2148
(02) 9674 8611

salesnsw@chainanddrives.com.au



A Mechanical Equipment Group Company