

DID 25 standard roller chain

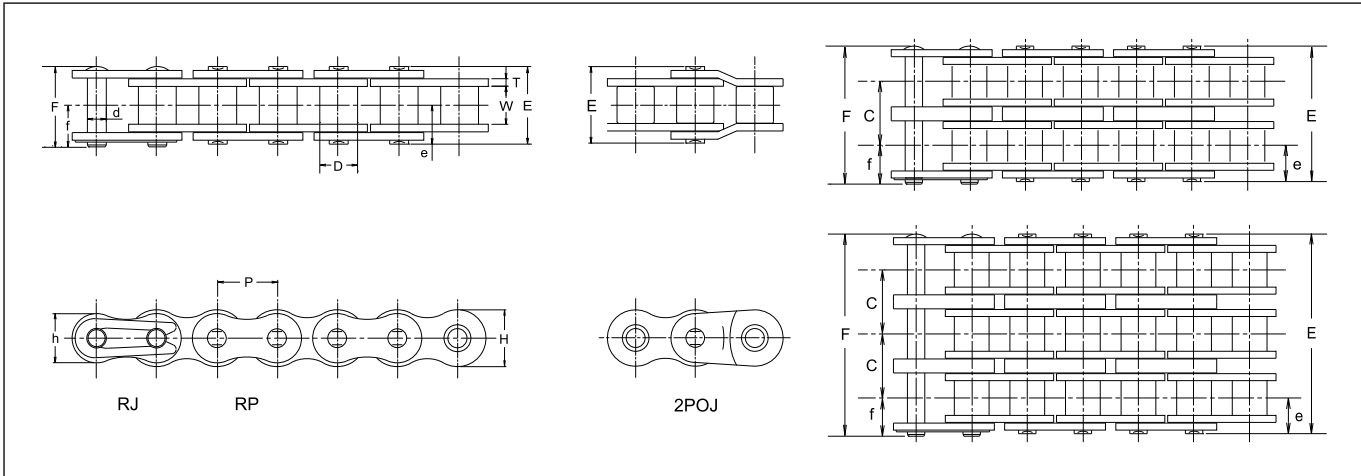

Dimensions

Unit (mm)

Chain No.	Pitch	Roller Link Width W	Bush Dia. D	Pin					Transverse Pitch C	Plate				JIS Min. Tensile Strength		DID Min. Tensile Strength		DID Avg. Tensile Strength		DID Max. Allowable Load		Approx. Weight (kg/m)
				d	E	F	e	f		T	H	h	kN	kgf	kN	kgf	kN	kgf	kN	kgf		
DID25	25				7.8	8.5								3.5	360	3.63	370	4.41	450	0.69	70	0.13
DID25-2	25-2				14.4	15.0								7	710	7.26	740	8.82	900	1.17	120	0.26
DID25-3	25-3	6.35	3.18	3.30	2.31	20.8	21.4	3.9	4.7	6.4	0.72	5.9	5.2	10.5	1,070	10.9	1,110	13.2	1,340	1.73	180	0.39
DID25-4	25-4					27.2	27.8							-	-	14.5	1,470	17.6	1,790	2.28	230	0.52
DID25-5	25-5					33.7	34.3							-	-	18.2	1,850	20	2,030	2.69	270	0.65

Note: Values of average tensile strength and max. allowable load are for chain body.

Max. Kilowatt Ratings

Unit (kW)

No. of Teeth of Small Sprocket	Small Sprocket revolutions per minute (rpm) (See P132 for the details of type of lubrication A, B and C.)																							
	A					B															C			
11	0.04	0.18	0.31	0.40	0.58	0.77	0.91	1.05	1.03	0.86	0.74	0.64	0.56	0.50	0.44	0.40	0.36	0.33	0.30	0.26				
12	0.05	0.20	0.34	0.44	0.63	0.85	1.00	1.15	1.17	0.98	0.84	0.73	0.64	0.57	0.51	0.46	0.41	0.38	0.35	0.30				
13	0.05	0.22	0.37	0.48	0.69	0.93	1.09	1.25	1.32	1.11	0.95	0.82	0.72	0.64	0.57	0.51	0.47	0.43	0.39	0.33				
14	0.06	0.24	0.40	0.52	0.75	1.00	1.18	1.36	1.48	1.24	1.06	0.92	0.80	0.71	0.64	0.58	0.52	0.48	0.44	0.37				
15	0.06	0.25	0.43	0.56	0.80	1.08	1.27	1.46	1.64	1.37	1.17	1.02	0.89	0.79	0.71	0.64	0.58	0.53	0.49	0.41				
16	0.06	0.27	0.46	0.60	0.86	1.16	1.37	1.57	1.77	1.51	1.29	1.12	0.98	0.87	0.78	0.70	0.64	0.58	0.53	0.46				
17	0.07	0.29	0.49	0.64	0.92	1.24	1.46	1.67	1.89	1.66	1.41	1.23	1.08	0.95	0.85	0.77	0.70	0.64	0.59	0.50				
18	0.07	0.31	0.52	0.68	0.98	1.32	1.55	1.78	2.01	1.81	1.54	1.34	1.17	1.04	0.93	0.84	0.76	0.70	0.64	0.54				
19	0.08	0.33	0.56	0.72	1.04	1.40	1.64	1.89	2.13	1.96	1.67	1.45	1.27	1.13	1.01	0.91	0.83	0.75	0.69	0.59				
20	0.08	0.35	0.59	0.76	1.10	1.47	1.74	2.00	2.25	2.11	1.81	1.56	1.37	1.22	1.09	0.98	0.89	0.81	0.75	0.64				
21	0.09	0.37	0.62	0.80	1.16	1.55	1.83	2.10	2.37	2.27	1.94	1.68	1.48	1.31	1.17	1.06	0.96	0.88	0.80	0.69				
22	0.09	0.38	0.65	0.84	1.22	1.63	1.93	2.21	2.50	2.44	2.08	1.81	1.58	1.40	1.26	1.13	1.03	0.94	0.86	0.74				
23	0.09	0.40	0.68	0.89	1.28	1.71	2.02	2.32	2.62	2.61	2.23	1.93	1.69	1.50	1.34	1.21	1.10	1.00	0.92	0.79				
24	0.10	0.42	0.72	0.93	1.34	1.80	2.12	2.43	2.74	2.78	2.37	2.06	1.81	1.60	1.43	1.29	1.17	1.07	0.98	0.84				
25	0.10	0.44	0.75	0.97	1.40	1.88	2.21	2.54	2.86	2.95	2.52	2.19	1.92	1.70	1.52	1.37	1.25	1.14	1.04	0.89				
28	0.12	0.50	0.85	1.10	1.58	2.12	2.50	2.87	3.24	3.50	2.99	2.59	2.27	2.02	1.81	1.63	1.48	1.35	1.24	1.06				
30	0.13	0.54	0.91	1.18	1.70	2.28	2.69	3.09	3.49	3.88	3.32	2.87	2.52	2.24	2.00	1.81	1.64	1.50	1.37	1.17				
32	0.14	0.58	0.98	1.27	1.82	2.45	2.89	3.32	3.74	4.16	3.65	3.17	2.78	2.46	2.21	1.99	1.81	1.65	1.51	1.29				
35	0.15	0.63	1.08	1.39	2.01	2.70	3.18	3.65	4.12	4.58	4.18	3.62	3.18	2.82	2.52	2.27	2.06	1.89	1.73	1.48				
40	0.17	0.73	1.24	1.61	2.32	3.12	3.67	4.22	4.76	5.29	5.11	4.43	3.88	3.44	3.08	2.78	2.52	2.30	2.11	1.81				
45	0.20	0.83	1.41	1.83	2.63	3.54	4.17	4.79	5.40	6.01	6.09	5.28	4.63	4.11	3.68	3.32	3.01	2.75	2.52	2.15				

Note: Values in the table above are for single strand chains only. For multiplex chains, please apply the coefficient of multi-strand. (See "Chain Selection" on P120).

DID 35 standard roller chain

Roller Chains for Power Transmission

Standard Roller Chain

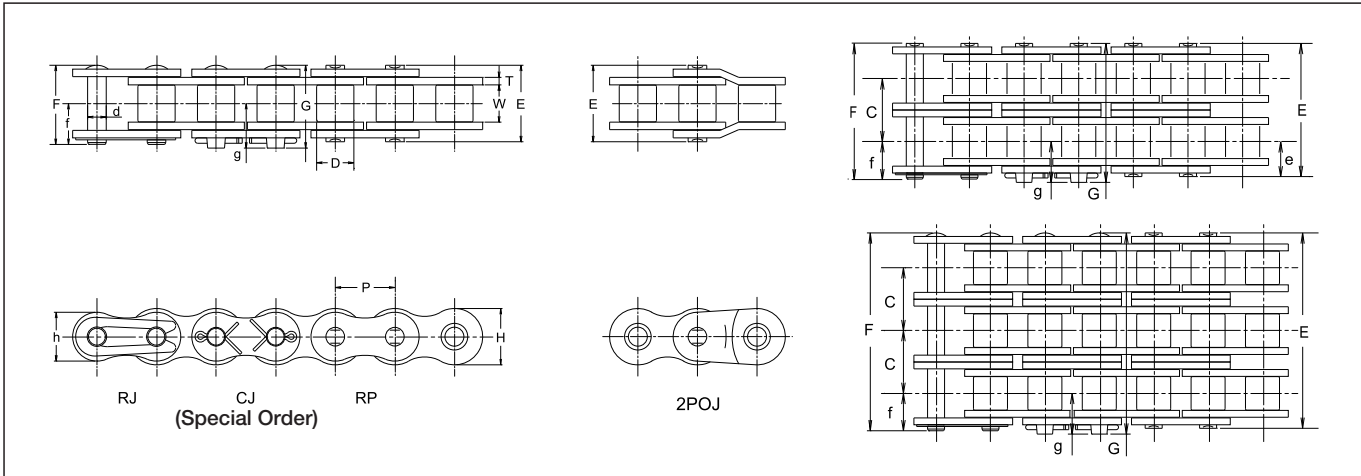

Dimensions

Unit (mm)

Chain No.	Pitch	Roller Link Width W	Bush Dia. D	Pin							Transvers e Pitch C	Plate				JIS Min. Tensile Strength		DID Min. Tensile Strength		DID Avg. Tensile Strength		DID Max. Allowable Load		Approx. Weight (kg/m)	
				d	E	F	G	e	f	g		T	H	h	kN	kgf	kN	kgf	kN	kgf	kN	kgf			
DID35	35				12.0	13.1	14.1										7.9	800	8.83	900	11.2	1,140	2.15	220	0.32
DID35-2	35-2				22.1	23.2	23.5										15.8	1,600	17.7	1,800	22.4	2,270	3.66	370	0.69
DID35-3	35-3	9.525	4.78	5.08	3.59	32.2	33.4	33.7	6.0	7.3	7.4	10.1	1.25	9.0	7.75		23.7	2,410	26.5	2,690	33.6	3,410	5.38	550	1.05
DID35-4	35-4					42.3	43.5	43.8									-	-	35.3	3,580	44.8	4,550	7.1	720	1.41
DID35-5	35-5					52.5	53.7	54.0									-	-	44.2	4,490	56	5,690	8.39	850	1.77

Note: The values of average tensile strength and Max. allowable tension are for chains.

Max. Kilowatt Ratings DID 35

Unit (kW)

No. of Teeth of Small Sprocket	Small Sprocket revolutions per minute (rpm) (See P132 for the details of type of lubrication A, B and C.)																																																																																																								
	100					500					900					1200					1500					1800					2500					3000					3500					4000					4500					5000					5500					6000					6500					7000					7500					8000					8500					9000					10000				
	A										B										C																																																																																				
11	0.21	0.92	1.56	2.02	2.47	2.91	2.88	2.19	1.73	1.42	1.19	1.01	0.88	0.77	0.68	0.61	0.55	0.50	0.45	0.42	0.36																																																																																				
12	0.23	1.01	1.71	2.22	2.71	3.20	3.28	2.49	1.98	1.62	1.35	1.16	1.00	0.88	0.78	0.70	0.63	0.57	0.52	0.48	0.41																																																																																				
13	0.25	1.10	1.87	2.42	2.96	3.49	3.70	2.81	2.23	1.82	1.53	1.30	1.13	0.99	0.88	0.78	0.71	0.64	0.59	0.54	0.46																																																																																				
14	0.28	1.19	2.02	2.62	3.21	3.78	4.13	3.14	2.49	2.04	1.71	1.46	1.26	1.11	0.98	0.88	0.79	0.72	0.65	0.60	0.51																																																																																				
15	0.30	1.28	2.18	2.83	3.46	4.07	4.58	3.48	2.76	2.26	1.89	1.62	1.40	1.23	1.09	0.97	0.88	0.80	0.73	0.67	0.57																																																																																				
16	0.32	1.38	2.34	3.03	3.71	4.37	5.05	3.84	3.05	2.49	2.09	1.78	1.54	1.35	1.20	1.07	0.97	0.88	0.80	0.73	0.63																																																																																				
17	0.34	1.47	2.50	3.24	3.96	4.66	5.53	4.20	3.34	2.73	2.29	1.95	1.69	1.48	1.32	1.18	1.06	0.96	0.88	0.81	0.69																																																																																				
18	0.36	1.56	2.66	3.44	4.21	4.96	6.02	4.58	3.63	2.97	2.49	2.13	1.84	1.62	1.43	1.28	1.16	1.05	0.96	0.88	0.75																																																																																				
19	0.39	1.66	2.82	3.65	4.46	5.26	6.53	4.97	3.94	3.23	2.70	2.31	2.00	1.75	1.55	1.39	1.25	1.14	1.04	0.95	0.81																																																																																				
20	0.41	1.75	2.98	3.86	4.72	5.56	7.06	5.37	4.26	3.48	2.92	2.49	2.16	1.89	1.68	1.50	1.35	1.23	1.12	1.03	0.88																																																																																				
21	0.43	1.85	3.14	4.07	4.97	5.86	7.59	5.78	4.58	3.75	3.14	2.68	2.32	2.04	1.81	1.62	1.46	1.32	1.21	1.11	0.94																																																																																				
22	0.45	1.94	3.30	4.28	5.23	6.16	8.14	6.19	4.91	4.02	3.37	2.88	2.49	2.19	1.94	1.73	1.56	1.42	1.29	1.19	1.01																																																																																				
23	0.47	2.04	3.46	4.49	5.49	6.47	8.69	6.62	5.25	4.30	3.60	3.07	2.66	2.34	2.07	1.85	1.67	1.52	1.38	1.27	1.08																																																																																				
24	0.50	2.13	3.63	4.70	5.74	6.77	9.10	7.06	5.60	4.58	3.84	3.28	2.84	2.49	2.21	1.98	1.78	1.62	1.48	1.35	1.16																																																																																				
25	0.52	2.23	3.79	4.91	6.00	7.07	9.51	7.50	5.95	4.87	4.08	3.48	3.02	2.65	2.35	2.10	1.89	1.72	1.57	1.44	1.23																																																																																				
28	0.59	2.52	4.28	5.55	6.79	8.00	10.8	8.89	7.06	5.78	4.84	4.13	3.58	3.14	2.79	2.49	2.25	2.04	1.86	1.71	1.46																																																																																				
30	0.63	2.72	4.61	5.98	7.31	8.62	11.6	9.86	7.83	6.41	5.37	4.58	3.97	3.48	3.09	2.76	2.49	2.26	2.06	1.89	1.62																																																																																				
32	0.68	2.91	4.95	6.41	7.84	9.24	12.4	10.9	8.62	7.06	5.91	5.05	4.37	3.84	3.40	3.05	2.75	2.49	2.27	2.09	-																																																																																				
35	0.75	3.21	5.45	7.06	8.64	10.2	13.7	12.4	9.86	8.07	6.76	5.78	5.01	4.39	3.89	3.48	3.14	2.85	2.60	2.39	-																																																																																				
40	0.87	3.71	6.30	8.16	9.98	11.8	15.8	15.2	12.1	9.86	8.27	7.06	6.12	5.37	4.76	4.26	3.84	3.48	-	-	-																																																																																				
45	0.99	4.21	7.15	9.27	11.3	13.4	18.0	18.1	14.4	11.8	9.86	8.42	7.30	6.41	5.68	5.08	4.58	-	-	-	-																																																																																				

Note: Values in the above table are for simplex chain only. For multiplex chains, please multiply the coefficient of multi-strand. (See "Chain Selection" on P.120).

DID 40 standard roller chain

Roller Chains for Power Transmission
Standard Roller Chain

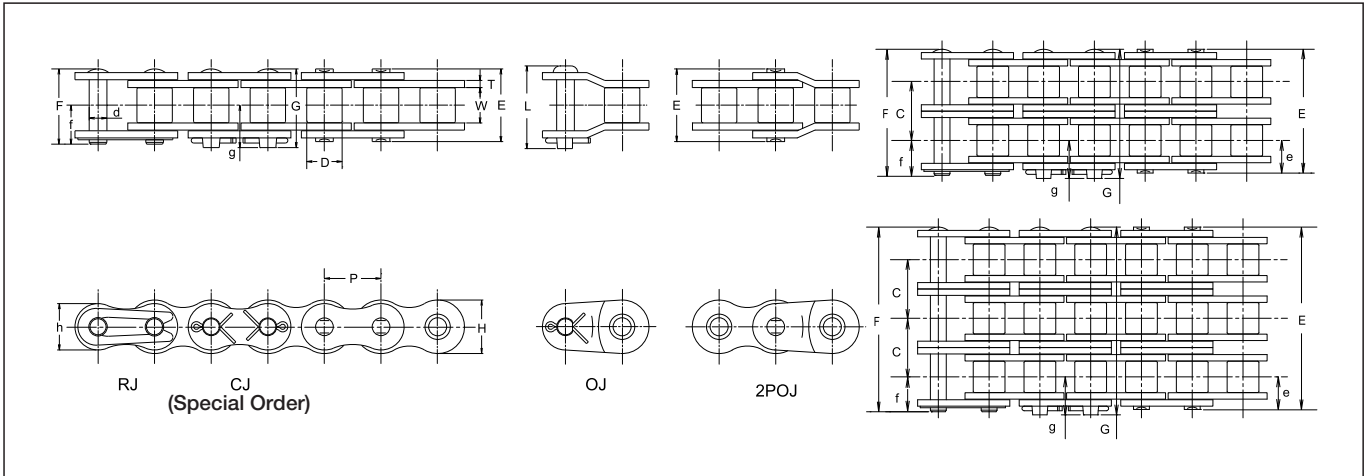

Dimensions

Unit (mm)

Chain No.	Pitch	Roller Link Width W	Roller dia. D	Pin									Transverse Pitch C	Plate				JIS		DID		DID		Approx. Weight (kg/m)	
				d	E	F	G	L	e	f	g	T		H	h	Min. Tensile Strength	Min. Tensile Strength	Avg. Tensile Strength	Max. Allowable Load						
DID	JIS	P	W	D	d	E	F	G	L	e	f	g	C	T	H	h	kN	kgf	kN	kgf	kN	kgf	kN	kgf	
DID40	40				16.5	17.6	18.1	19.1									13.9	1,410	15.7	1,590	19.1	1,940	3.72	380	0.63
DID40-2	40-2				31.0	32.1	32.6	33.6									27.8	2,820	31.4	3,190	38.2	3,880	6.32	640	1.19
DID40-3	40-3	12.70	7.95	7.92	3.97	45.4	46.4	47.0	47.9	8.3	9.5	10.1	14.4	1.50	12.0	10.4	41.7	4,230	47.1	4,780	57.3	5,820	9.3	940	1.78
DID40-4	40-4				59.9	61.0	61.4	61.4									—	—	62.8	6,380	76.4	7,760	12.3	1,250	2.37
DID40-5	40-5				74.3	75.4	75.8	75.8									—	—	78.5	7,970	95.5	9,700	14.5	1,470	2.96

Note: The values of average tensile strength and Max. allowable tension are for chains.

Max. Kilowatt Ratings DID 40

Unit (kW)

Type of Lubrication No. of Teeth of Small Sprocket	Small sprocket rpm (Refer to P132 for the details of lubrication A, B and C.)																			
	50	200	400	600	900	1200	1500	1800	2400	3000	3500	4000	4500	5000	5500	6000	6500	7000	7500	8000
	A					B					C									
11	0.34	1.21	2.25	3.25	4.68	5.07	4.57	3.47	2.25	1.61	1.28	1.05	0.88	0.75	0.65	0.57	0.50	0.45	0.40	0.37
12	0.38	1.33	2.48	3.57	5.15	5.67	5.21	3.96	2.57	1.84	1.46	1.19	1.00	0.85	0.74	0.65	0.57	0.51	0.46	0.42
13	0.41	1.45	2.70	3.89	5.61	6.18	5.87	4.46	2.90	2.07	1.64	1.34	1.13	0.96	0.83	0.73	0.65	0.58	0.52	0.47
14	0.45	1.57	2.93	4.22	6.08	6.70	6.56	4.99	3.24	2.32	1.84	1.50	1.26	1.07	0.93	0.82	0.72	0.65	0.58	0.53
15	0.48	1.69	3.15	4.55	6.55	7.21	7.21	5.54	3.59	2.57	2.04	1.67	1.40	1.19	1.03	0.91	0.80	0.72	0.65	—
16	0.52	1.81	3.38	4.87	7.02	7.74	7.74	6.10	3.96	2.83	2.25	1.84	1.54	1.31	1.14	1.00	0.88	0.79	0.71	—
17	0.55	1.93	3.61	5.20	7.50	8.26	8.26	6.68	4.34	3.10	2.46	2.01	1.69	1.44	1.25	1.09	0.97	0.87	0.78	—
18	0.59	2.06	3.84	5.54	7.98	8.79	8.79	7.28	4.73	3.38	2.68	2.19	1.84	1.57	1.36	1.19	1.06	0.94	0.85	—
19	0.62	2.18	4.07	5.87	8.46	9.43	9.43	7.89	5.12	3.67	2.91	2.38	1.99	1.70	1.47	1.29	1.15	1.02	0.92	—
20	0.66	2.30	4.31	6.20	8.94	10.2	10.2	8.52	5.54	3.96	3.14	2.57	2.15	1.84	1.59	1.40	1.24	1.11	1.00	—
21	0.69	2.43	4.54	6.54	9.42	11.0	11.0	9.17	5.96	4.26	3.38	2.77	2.32	1.98	1.71	1.50	1.33	1.19	—	—
22	0.73	2.56	4.77	6.88	9.91	11.7	11.7	9.84	6.39	4.57	3.62	2.97	2.48	2.12	1.84	1.61	1.43	1.28	—	—
23	0.77	2.68	5.01	7.22	10.4	12.6	12.6	10.5	6.83	4.88	3.87	3.17	2.66	2.27	1.96	1.72	1.53	1.37	—	—
24	0.80	2.81	5.24	7.55	10.9	13.4	13.4	11.2	7.28	5.21	4.13	3.38	2.83	2.42	2.09	1.84	1.63	1.46	—	—
25	0.84	2.93	5.48	7.90	11.4	14.1	14.1	11.9	7.74	5.54	4.39	3.59	3.01	2.57	2.23	1.95	1.73	—	—	—
28	0.95	3.32	6.19	8.92	12.9	16.0	16.0	14.1	9.17	6.56	5.21	4.26	3.57	3.05	2.64	2.32	2.05	—	—	—
30	1.02	3.57	6.67	9.61	13.9	17.2	17.2	15.7	10.2	7.28	5.77	4.73	3.96	3.38	2.93	2.57	—	—	—	—
32	1.10	3.83	7.16	10.3	14.9	18.4	18.4	17.3	11.2	8.02	6.36	5.21	4.36	3.72	3.23	2.83	—	—	—	—
35	1.21	4.22	7.88	11.4	16.4	20.7	20.7	19.7	12.8	9.17	7.28	5.96	4.99	4.26	3.69	—	—	—	—	—
40	1.40	4.88	9.11	13.1	18.9	24.1	24.1	24.1	15.7	11.2	8.89	7.28	6.10	5.21	—	—	—	—	—	—
45	1.59	5.54	10.3	14.9	21.5	27.4	27.4	27.4	18.7	13.4	10.6	8.69	7.28	—	—	—	—	—	—	—

Note: Values in the above table are for simplex chain only. For multiplex chains, please multiply the coefficient of multi-strand. (See "Chain Selection" on P120).

DID 41 standard roller chain

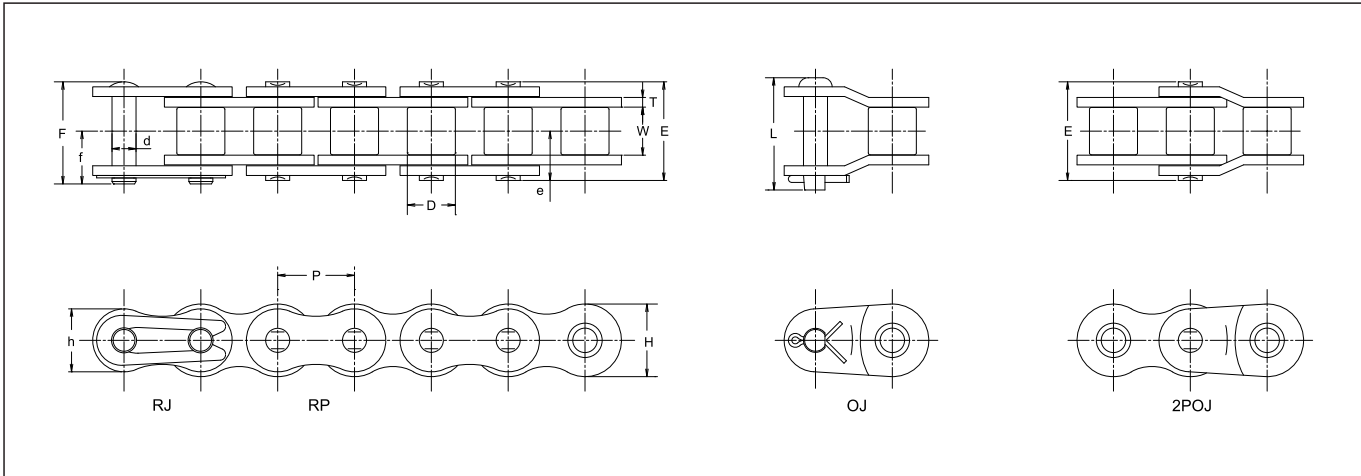

Dimensions

Unit (mm)

Chain No.		Pitch P	Roller Link Width W	Roller dia. D	Pin						Plate			JIS Min. Tensile Strength		DID Min. Tensile Strength		DID Avg. Tensile Strength		DID Max. Allowable Load		Approx. Weight (kg/m)
DID	JIS				d	E	F	L	e	f	T	H	h	kN	kgf	kN	kgf	kN	kgf	kN	kgf	
DID 41	41	12.70	6.38	7.77	3.59	13.7	14.6	15.5	6.9	7.9	1.20	9.6	8.0	6.7	680	8.83	900	10.7	1,090	2.35	240	0.39

Note: The values of average tensile strength and Max. allowable tension are for chains.

Max. Kilowatt Ratings DID 41

Unit (kW)

No. of Teeth of Small Sprocket	Small sprocket rpm (Refer to P132 for the details of lubrication A, B and C.)																																																							
	50			200			400			600			900			1200			1800			2400			3000			3500			4000			4500			5000			5500			6000			6500			7000			7500			8000	
Type of Lubrication	A						B						C																																											
11	0.11	0.40	0.74	1.06	1.53	1.28	0.69	0.45	0.32	0.26	0.21	0.18	0.15	0.13	0.11	0.10	0.09	0.08	0.07																																					
12	0.12	0.43	0.81	1.17	1.68	1.45	0.79	0.51	0.37	0.29	0.24	0.20	0.17	0.15	0.13	0.12	0.10	0.09	0.08																																					
13	0.14	0.47	0.88	1.27	1.84	1.64	0.89	0.58	0.41	0.33	0.27	0.23	0.19	0.17	0.15	0.13	0.12	0.10	0.10																																					
14	0.15	0.51	0.96	1.38	1.99	1.83	1.00	0.65	0.46	0.37	0.30	0.25	0.22	0.19	0.16	0.15	0.13	0.12	0.11																																					
15	0.16	0.55	1.03	1.49	2.14	2.03	1.11	0.72	0.51	0.41	0.33	0.28	0.24	0.21	0.18	0.16	0.14	0.13	—																																					
16	0.17	0.59	1.11	1.59	2.30	2.24	1.22	0.79	0.57	0.45	0.37	0.31	0.26	0.23	0.20	0.18	0.16	0.14	—																																					
17	0.18	0.63	1.18	1.70	2.45	2.45	1.33	0.87	0.62	0.49	0.40	0.34	0.29	0.25	0.22	0.19	0.17	0.16	—																																					
18	0.19	0.67	1.26	1.81	2.61	2.67	1.45	0.94	0.68	0.54	0.44	0.37	0.31	0.27	0.24	0.21	0.19	0.17	—																																					
19	0.21	0.71	1.33	1.92	2.77	2.90	1.58	1.02	0.73	0.58	0.48	0.40	0.34	0.30	0.26	0.23	0.21	0.19	—																																					
20	0.22	0.76	1.41	2.03	2.92	3.13	1.70	1.11	0.79	0.63	0.51	0.43	0.37	0.32	0.28	0.25	0.22	0.20	—																																					
21	0.23	0.80	1.49	2.14	3.08	3.36	1.83	1.19	0.85	0.68	0.55	0.46	0.40	0.34	0.30	0.27	0.24	0.22	—																																					
22	0.24	0.84	1.56	2.25	3.24	3.61	1.96	1.28	0.91	0.72	0.59	0.50	0.42	0.37	0.32	0.29	0.26	—	—																																					
23	0.25	0.88	1.64	2.36	3.40	3.86	2.10	1.36	0.98	0.77	0.63	0.53	0.45	0.39	0.34	0.31	0.27	—	—																																					
24	0.26	0.92	1.72	2.47	3.56	4.11	2.24	1.45	1.04	0.83	0.68	0.57	0.48	0.42	0.37	0.33	0.29	—	—																																					
25	0.28	0.96	1.79	2.58	3.72	4.37	2.38	1.54	1.11	0.88	0.72	0.60	0.51	0.45	0.39	0.35	—	—	—																																					
28	0.31	1.09	2.03	2.92	4.20	5.18	2.82	1.83	1.31	1.04	0.85	0.71	0.61	0.53	0.46	0.41	—	—	—																																					
30	0.34	1.17	2.18	3.14	4.53	5.74	3.13	2.03	1.45	1.15	0.94	0.79	0.68	0.59	0.51	—	—	—	—																																					
32	0.36	1.25	2.34	3.37	4.86	6.29	3.44	2.24	1.60	1.27	1.04	0.87	0.74	0.64	0.57	—	—	—	—																																					
35	0.40	1.38	2.58	3.71	5.35	6.93	3.94	2.56	1.83	1.45	1.19	1.00	0.85	0.74	—	—	—	—	—																																					
40	0.46	1.60	2.98	4.29	6.18	8.01	4.81	3.13	2.24	1.78	1.45	1.22	1.04	—	—	—	—	—	—																																					
45	0.52	1.81	3.38	4.87	7.02	9.09	5.74	3.73	2.67	2.12	1.73	1.45	—	—	—	—	—	—	—																																					

DID 50 standard roller chain

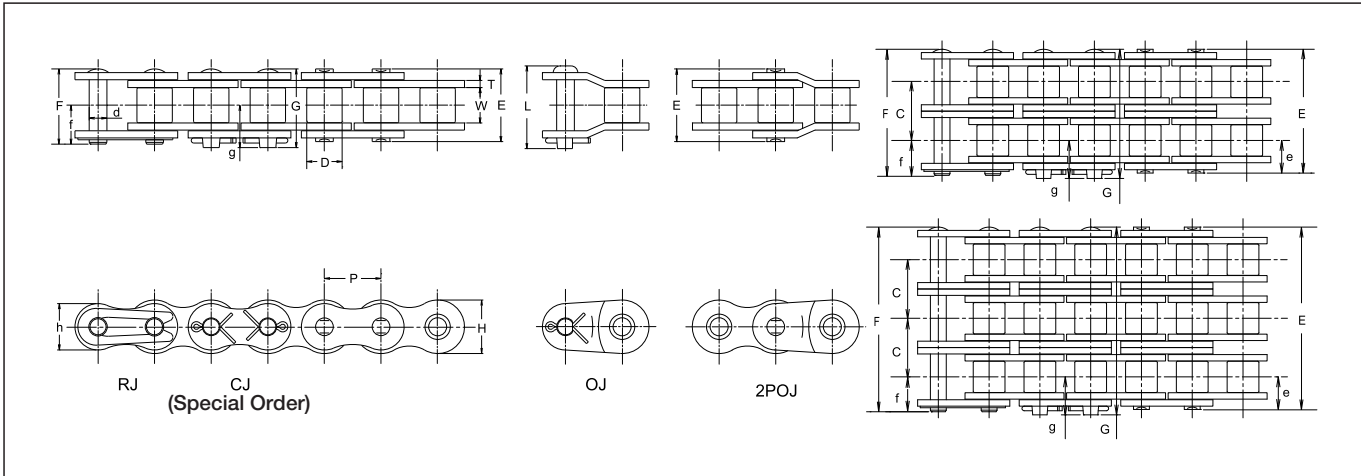

Dimensions

Unit (mm)

Chain No.	Pitch	Roller Link Width W	Roller dia. D	Pin									Transverse Pitch C	Plate				JIS Min. Tensile Strength		DID Min. Tensile Strength		DID Avg. Tensile Strength		DID Max. Allowable Load		Approx. Weight (kg/m)
				d	E	F	G	L	e	f	g	T		H	h	kN	kgf	kN	kgf	kN	kgf	kN	kgf			
DID50	50				20.3	21.9	22.1	23.2										21.8	2,210	26.5	2,690	30.8	3,130	6.86	700	1.06
DID50-2	50-2				38.5	40.1	40.3	41.3										43.6	4,430	53	5,380	61.6	6,250	11.7	1,190	2.04
DID50-3	50-3	15.875	9.53	10.16	5.09	56.7	58.3	58.5	59.5	10.2	11.6	12.1	18.1	2.00	15.0	13.0		65.4	6,640	79.5	8,070	92.4	9,380	17.2	1,750	3.06
DID50-4	50-4					74.8	76.4	76.6	76.6									-	-	106	10,760	123	12,490	22.6	2,290	4.06
DID50-5	50-5					93.0	94.5	94.7	94.7									-	-	132	13,400	154	15,630	26.8	2,720	5.08

Note: The values of average tensile strength and Max. allowable tension are for chains.

Max. Kilowatt Ratings DID 50

Unit (kW)

No. of Teeth of Small Sprocket	Small Sprocket revolutions per minute (rpm) (See P132 for the details of type of lubrication A, B and C.)																																																																																									
	50					100					300					900					1200					1500					1800					2100					2400					2700					3000					3300					3500					4000					4500					5000					5400					5800				
	A										B										C																																																																					
11	0.76	1.42	3.82	6.05	7.88	7.64	5.46	4.15	3.30	2.70	2.26	1.93	1.67	1.53	1.25	1.05	0.89	0.80	0.71																																																																							
12	0.83	1.56	4.19	6.64	8.71	8.70	6.22	4.73	3.76	3.07	2.57	2.20	1.90	1.74	1.43	1.19	1.02	0.91	0.81																																																																							
13	0.91	1.70	4.57	7.24	9.82	9.81	7.02	5.34	4.24	3.47	2.90	2.48	2.15	1.97	1.61	1.35	1.15	1.02	0.92																																																																							
14	0.98	1.84	4.95	7.85	11.0	11.0	7.85	5.97	4.73	3.87	3.25	2.77	2.40	2.20	1.80	1.51	1.28	1.14	-																																																																							
15	1.06	1.98	5.34	8.45	12.2	12.2	8.70	6.62	5.25	4.30	3.60	3.07	2.66	2.44	1.99	1.67	1.43	1.27	-																																																																							
16	1.14	2.13	5.72	9.06	13.4	13.4	9.59	7.29	5.78	4.73	3.97	3.39	2.93	2.69	2.20	1.84	1.57	1.40	-																																																																							
17	1.21	2.27	6.11	9.68	14.7	14.7	10.5	7.99	6.34	5.19	4.34	3.71	3.21	2.94	2.41	2.02	1.72	1.53	-																																																																							
18	1.29	2.41	6.50	10.3	15.8	15.8	11.4	8.70	6.90	5.65	4.73	4.04	3.50	3.21	2.62	2.20	1.88	-	-																																																																							
19	1.37	2.56	6.89	10.9	16.8	16.8	12.4	9.44	7.49	6.13	5.13	4.38	3.80	3.48	2.85	2.38	2.03	-	-																																																																							
20	1.45	2.71	7.28	11.5	17.7	17.7	13.4	10.2	8.09	6.62	5.55	4.73	4.10	3.76	3.07	2.57	2.20	-	-																																																																							
21	1.53	2.85	7.68	12.2	18.7	18.7	14.4	11.0	8.70	7.12	5.97	5.09	4.41	4.04	3.31	2.77	2.36	-	-																																																																							
22	1.61	3.00	8.07	12.8	19.6	19.6	15.5	11.8	9.33	7.64	6.40	5.46	4.73	4.33	3.55	2.97	2.54	-	-																																																																							
23	1.68	3.15	8.47	13.4	20.6	20.6	16.5	12.6	9.97	8.16	6.84	5.84	5.06	4.63	3.79	3.18	-	-	-																																																																							
24	1.76	3.30	8.87	14.1	21.6	21.6	17.6	13.4	10.6	8.70	7.29	6.22	5.39	4.94	4.04	3.39	-	-	-																																																																							
25	1.84	3.44	9.27	14.7	22.5	22.5	18.7	14.3	11.3	9.25	7.75	6.62	5.74	5.25	4.30	3.60	-	-	-																																																																							
28	2.08	3.89	10.5	16.6	26.8	26.8	22.2	16.9	13.4	11.0	9.19	7.85	6.80	6.22	5.09	-	-	-	-																																																																							
30	2.25	4.20	11.3	17.9	29.1	29.1	24.6	18.7	14.9	12.2	10.2	8.70	7.54	6.90	5.65	-	-	-	-																																																																							
32	2.41	4.50	12.1	19.2	31.4	31.4	27.1	20.6	16.4	13.4	11.2	9.59	8.31	7.61	6.22	-	-	-	-																																																																							
35	2.65	4.96	13.3	21.1	34.4	34.4	31.0	23.6	18.7	15.3	12.8	11.0	9.50	8.70	7.12	-	-	-	-																																																																							
40	3.07	5.73	15.4	24.4	40.4	40.4	37.9	28.8	22.9	18.7	15.7	13.4	11.6	10.6	-	-	-	-	-																																																																							
45	3.48	6.50	17.5	27.7	46.0	46.0	45.2	34.4	27.3	22.4	18.7	16.0	13.9	-	-	-	-	-	-																																																																							

Note: Values in the table above are for simplex chain only. For multiplex chains, please multiply the coefficient of multi-strand. (See "Chain Selection" on P120).

Roller Chains for Power Transmission **Standard Roller Chain**

DID 60 standard roller chain

Roller Chains for Power Transmission

Standard Roller Chain

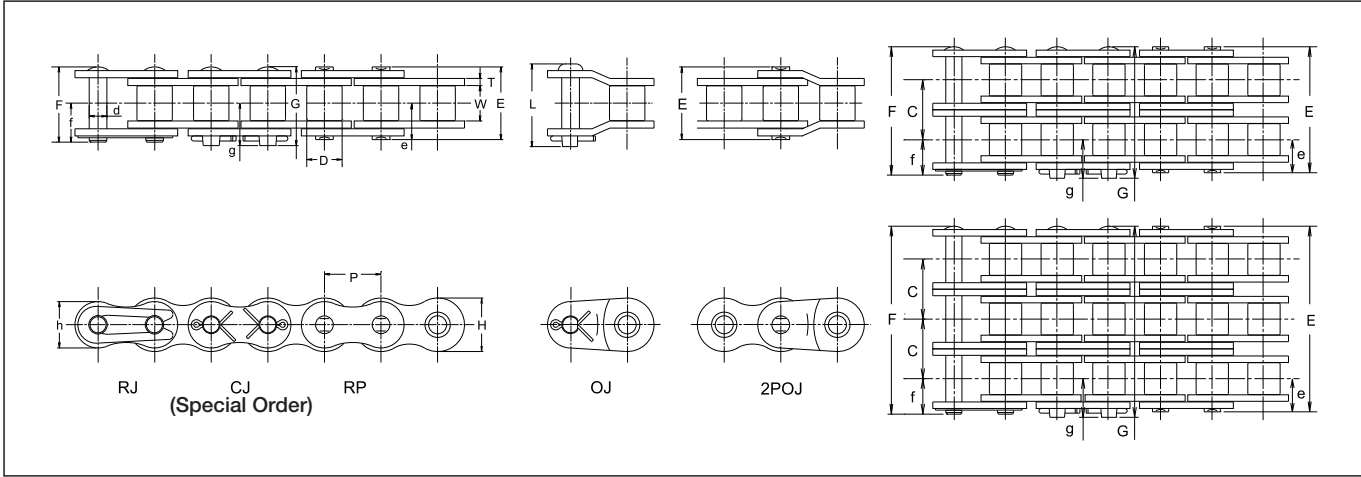

Dimensions

Unit (mm)

Chain No.	Pitch	Roller Link Width W	Roller dia. D	Pin									Transverse Pitch C	Plate				JIS		DID		DID		Approx. Weight (kg/m)	
				d	E	F	G	L	e	f	g	T		H	h	Min. Tensile Strength		Min. Tensile Strength		Avg. Tensile Strength		Max. Allowable Load			
																kN	kgf	kN	kgf	kN	kgf	kN	kgf		
DID60	60				25.4	26.9	27.9	29.8									31.3	3,180	35.3	3,580	44.1	4,480	9.31	950	1.53
DID60-2	60-2				48.3	49.8	50.9	52.5									62.6	6,360	70.6	7,170	88.2	8,950	15.8	1,600	3.03
DID60-3	60-3	19.05	12.70	11.91	5.96	71.2	72.7	73.7	75.3	12.7	14.3	15.1	22.8	2.40	18.1	15.6	93.9	9,530	106	10,760	132	13,400	23.3	2,370	4.51
DID60-4	60-4					94.0	95.5	96.5	96.5								-	-	141	14,310	176	17,870	30.7	3,120	6.03
DID60-5	60-5					116.8	118.8	119.3	119.3								-	-	177	17,970	221	22,440	36.3	3,690	7.53

Note: The values of average tensile strength and Max. allowable tension are for chains.

Max. Kilowatt Ratings DID 60

Unit (kW)

Type of Lubrication No. of Teeth of Small Sprocket	Small Sprocket revolutions per minute (rpm) (See P132 for the details of type of lubrication A, B and C.)																																																																															
	50				100				200				500				700				900				1200				1400				1500				1600				1800				2000				2200				2400				2600				2800				3000				3500				3800				4000			
	A				B				C				A				B				C				A				B				C				A				B				C				A				B				C				A				B				C											
11	1.26	2.36	4.40	10.1	12.7	12.7	8.84	7.01	6.32	5.74	4.81	4.10	3.56	3.12	2.77	2.48	2.23	1.77	1.56	1.45																																																												
12	1.39	2.59	4.84	11.0	13.9	13.9	10.1	7.99	7.20	6.54	5.48	4.68	4.05	3.56	3.15	2.82	2.54	2.02	1.78	1.65																																																												
13	1.51	2.83	5.28	12.0	15.2	15.2	11.4	9.01	8.12	7.37	6.18	5.27	4.57	4.01	3.56	3.18	2.87	2.28	2.01	1.86																																																												
14	1.64	3.06	5.72	13.1	16.7	16.7	12.7	10.1	9.08	8.24	6.90	5.89	5.11	4.48	3.98	3.56	3.21	2.54	2.25	2.08																																																												
15	1.77	3.30	6.16	14.1	18.5	18.5	14.1	11.2	10.1	9.14	7.66	6.54	5.67	4.97	4.41	3.94	3.56	2.82	2.49	2.31																																																												
16	1.89	3.54	6.60	15.1	20.4	20.4	15.5	12.3	11.1	10.1	8.44	7.20	6.24	5.48	4.86	4.35	3.92	3.11	2.75	2.54																																																												
17	2.02	3.78	7.05	16.1	21.8	22.3	17.0	13.5	12.2	11.0	9.24	7.89	6.84	6.00	5.32	4.76	4.29	3.40	3.01	2.79																																																												
18	2.15	4.02	7.50	17.1	23.2	23.7	18.5	14.7	13.2	12.0	10.1	8.60	7.45	6.54	5.80	5.19	4.68	3.71	3.28	3.04																																																												
19	2.28	4.26	7.95	18.1	24.6	25.1	20.1	15.9	14.4	13.0	10.9	9.32	8.08	7.09	6.29	5.63	5.07	4.02	3.56	3.29																																																												
20	2.41	4.50	8.40	19.2	26.0	26.6	21.7	17.2	15.5	14.1	11.8	10.1	8.73	7.66	6.79	6.08	5.48	4.35	3.84	3.56																																																												
21	2.54	4.75	8.86	20.2	27.4	28.0	23.3	18.5	16.7	15.1	12.7	10.8	9.39	8.24	7.31	6.54	5.89	4.68	4.13	3.83																																																												
22	2.67	4.99	9.32	21.3	28.8	29.5	25.0	19.8	17.9	16.2	13.6	11.6	10.1	8.84	7.84	7.01	6.32	5.01	4.43	4.10																																																												
23	2.80	5.24	9.77	22.3	30.2	30.9	26.7	21.2	19.1	17.4	14.5	12.4	10.8	9.45	8.38	7.49	6.76	5.36	4.74	4.39																																																												
24	2.94	5.48	10.2	23.4	31.6	32.5	28.5	22.6	20.4	18.5	15.5	13.2	11.5	10.1	8.93	7.99	7.20	5.71	5.05	4.68																																																												
25	3.07	5.73	10.7	24.4	33.0	34.5	30.3	24.0	21.7	19.7	16.5	14.1	12.2	10.7	9.49	8.49	7.66	6.08	5.37	4.97																																																												
28	3.47	6.48	12.1	27.6	37.3	40.9	35.9	28.5	25.7	23.3	19.5	16.7	14.5	12.7	11.3	10.1	9.08	7.20	6.37	-																																																												
30	3.74	6.98	13.0	29.7	40.2	44.9	39.8	31.6	28.5	25.9	21.7	18.5	16.0	14.1	12.5	11.2	10.1	7.99	-	-																																																												
32	4.01	7.48	14.0	31.9	43.1	48.1	43.9	34.8	31.4	28.5	23.9	20.4	17.7	15.5	13.8	12.3	11.1	8.80	-	-																																																												
35	4.41	8.24	15.4	35.1	47.5	53.0	50.2	39.8	35.9	32.6	27.3	23.3	20.2	17.7	15.7	14.1	12.7	-	-	-																																																												
40	5.10	9.52	17.8	40.6	54.9	61.3	61.3	48.6	43.9	39.8	33.4	28.5	24.7	21.7	19.2	17.2	15.5	-	-	-																																																												
45	5.79	10.8	20.2	46.1	62.3	69.4	69.4	58.0	52.3	47.5	39.8	34.0	29.5	25.9	22.9	20.5	-	-	-	-																																																												

Note: Values in the table above are for simplex chain only. For multiplex chains, please multiply the coefficient of multi-strand. (See "Chain Selection" on P120).

DID 80 standard roller chain

Roller Chains for Power Transmission

Standard Roller Chain

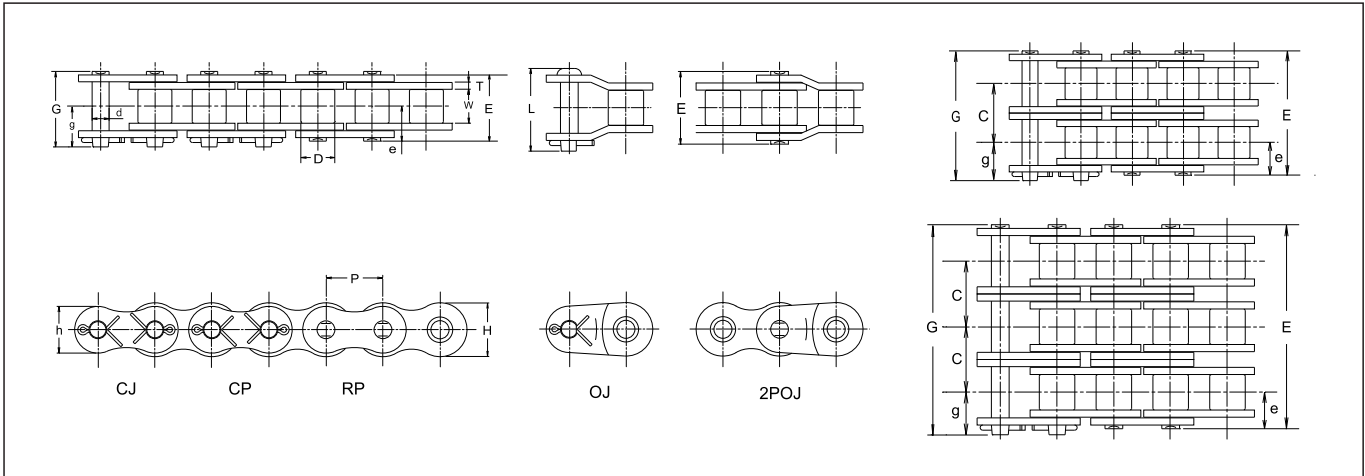

Dimensions

Unit (mm)

Chain No.	Pitch	Roller Link Width	Roller dia.	Pin						Transverse Pitch	Plate			JIS		DID		DID		Approx. Weight (kg/m)			
				d	E	G	L	e	g		C	T	H	h	Min. Tensile Strength	Min. Tensile Strength	Avg. Tensile Strength	Max. Allowable Load					
DID	JIS	P	W	D	d	E	G	L	e	g	C	T	H	h	kN	kgf	kN	kgf	kN	kgf	kN	kgf	
DID80	80					32.6	35.4	37.1							55.6	5,640	71.6	7,270	78.4	7,960	14.7	1,490	2.55
DID80-2	80-2					61.9	64.7	66.3							111.2	11,290	143	14,520	157	15,940	25	2,540	5.07
DID80-3	80-3	25.40	15.88	15.88	7.94	91.3	94.0	95.1	16.3	19.00	29.3	3.20	24.0	20.8	166.8	16,930	215	21,830	235	23,860	36.8	3,740	7.58
DID80-4	80-4					120.6	123.3	124.4							—	—	286	29,040	314	31,880	48.5	4,920	10.1
DID80-5	80-5					149.9	152.6	153.7							—	—	358	36,350	392	39,800	57.3	5,820	12.6

Note: The values of average tensile strength and Max. allowable tension are for chains.

Max. Kilowatt Ratings DID 80

Unit (kW)

No. of Teeth of Small Sprocket	Small Sprocket revolutions per minute (rpm) (See P132 for the details of type of lubrication A, B and C.)																											
	A			B												C												
Type of Lubrication	20	50	100	200	300	400	500	700	900	1000	1200	1400	1500	1600	1800	2000	2200	2400	2600	2700	2800	3000	3200	3400				
11	1.22	2.79	5.21	9.73	14.0	18.2	22.2	22.8	17.1	14.6	11.1	8.83	7.96	7.22	6.05	5.17	4.48	3.93	3.48	3.29	3.12	2.81	2.55	2.33				
12	1.34	3.07	5.73	10.7	15.4	20.0	24.4	25.0	19.5	16.7	12.7	10.1	9.07	8.23	6.90	5.89	5.10	4.48	3.97	3.75	3.55	3.20	2.91	2.65				
13	1.46	3.34	6.25	11.7	16.8	21.8	26.6	27.3	22.0	18.8	14.3	11.3	10.2	9.28	7.78	6.64	5.75	5.05	4.48	4.23	4.01	3.61	3.28	2.99				
14	1.59	3.62	6.77	12.6	18.2	23.6	28.8	29.5	24.6	21.0	16.0	12.7	11.4	10.4	8.69	7.42	6.43	5.64	5.01	4.73	4.48	4.04	3.66	3.35				
15	1.71	3.90	7.29	13.6	19.6	25.4	31.1	32.6	27.3	23.3	17.7	14.1	12.7	11.5	9.64	8.23	7.13	6.26	5.55	5.25	4.97	4.48	4.06	—				
16	1.83	4.19	7.82	14.6	21.0	27.2	33.3	35.9	30.1	25.7	19.5	15.5	14.0	12.7	10.6	9.07	7.86	6.90	6.12	5.78	5.47	4.93	4.48	—				
17	1.96	4.47	8.35	15.6	22.4	29.1	35.5	39.3	32.9	28.1	21.4	17.0	15.3	13.9	11.6	9.93	8.61	7.55	6.70	6.33	5.99	5.40	4.90	—				
18	2.08	4.75	8.88	16.6	23.9	30.9	37.8	42.8	35.9	30.6	23.3	18.5	16.7	15.1	12.7	10.8	9.38	8.23	7.30	6.90	6.53	5.89	5.34	—				
19	2.21	5.04	9.41	17.6	25.3	32.8	40.1	46.0	38.9	33.2	25.3	20.0	18.1	16.4	13.8	11.7	10.2	8.93	7.92	7.48	7.08	6.39	—	—				
20	2.33	5.33	9.95	18.6	26.8	34.7	42.4	48.7	42.0	35.9	27.3	21.7	19.5	17.7	14.9	12.7	11.0	9.64	8.55	8.08	7.65	6.90	—	—				
21	2.46	5.62	10.5	19.6	28.2	36.5	44.7	51.3	45.2	38.6	29.4	23.3	21.0	19.1	16.0	13.6	11.8	10.4	9.20	8.69	8.23	7.42	—	—				
22	2.59	5.91	11.0	20.6	29.7	38.4	47.0	53.9	48.5	41.4	31.5	25.0	22.5	20.4	17.1	14.6	12.7	11.1	9.86	9.32	8.83	7.96	—	—				
23	2.71	6.20	11.6	21.6	31.1	40.3	49.3	56.6	51.8	44.2	33.6	26.7	24.1	21.9	18.3	15.6	13.6	11.9	10.5	9.96	9.44	8.65	—	—				
24	2.84	6.49	12.1	22.6	32.6	42.2	51.6	59.3	55.2	47.1	35.9	28.5	25.7	23.3	19.5	16.7	14.4	12.7	11.2	10.6	10.1	—	—	—				
25	2.97	6.78	12.7	23.6	34.0	44.1	53.9	61.9	58.7	50.1	38.1	30.3	27.3	24.8	20.8	17.7	15.4	13.5	12.0	11.3	10.7	—	—	—				
28	3.36	7.67	14.3	26.7	38.5	49.8	60.9	73.5	69.6	59.4	45.2	35.9	32.3	29.4	24.6	21.0	18.2	16.0	14.2	13.4	—	—	—	—				
30	3.62	8.26	15.4	28.8	41.5	53.7	65.6	79.6	77.2	65.9	50.1	39.8	35.9	32.6	27.3	23.3	20.2	17.7	15.7	6.03	—	—	—	—				
32	3.88	8.86	16.5	30.9	44.4	57.6	70.4	85.0	85.0	72.6	55.2	43.8	39.5	35.9	30.1	25.7	22.2	19.5	—	—	—	—	—	—				
35	4.27	9.76	18.2	34.0	49.0	63.4	77.5	95.0	95.0	83.0	63.2	50.1	45.2	41.0	34.4	29.4	25.4	—	—	—	—	—	—	—				
40	4.94	11.3	21.0	39.3	56.6	73.3	89.6	110	110	101	77.2	61.2	55.2	50.1	42	35.9	—	—	—	—	—	—	—	—				
45	5.61	12.8	23.9	44.6	64.2	83.2	102	126	126	121	92.1	73.1	65.9	59.8	50.1	—	—	—	—	—	—	—	—	—				

Note: 1. Values in the table above are for simplex chain only. For multiplex chains, please multiply the coefficient of multi-strand. (See "Chain Selection" on P120).
 2. Consult us when the ratings beyond the dotted line to rightward.

DID 100 standard roller chain

Roller Chains for Power Transmission

Standard Roller Chain

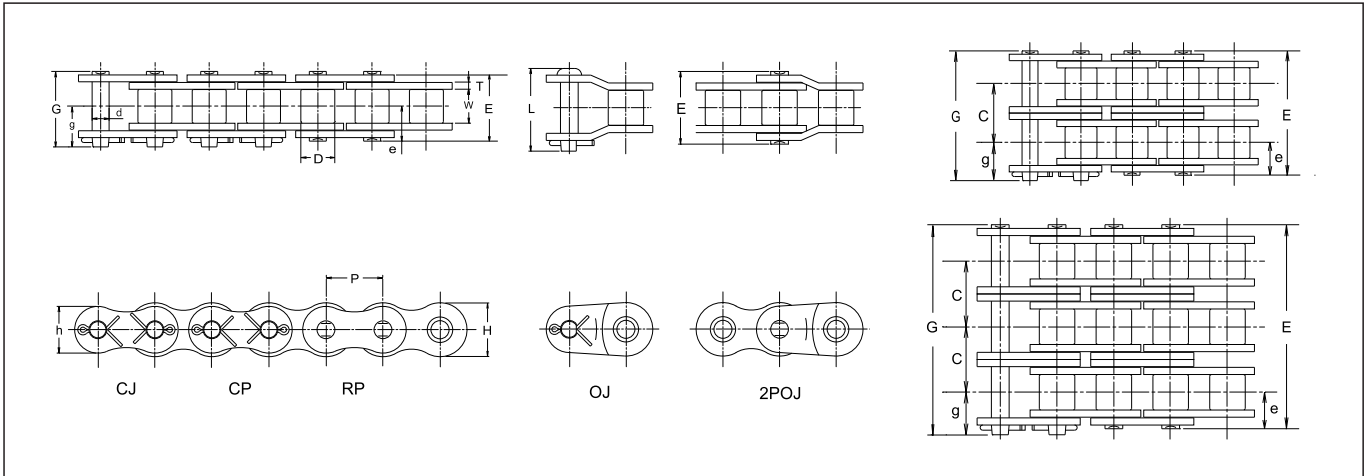

Dimensions

Unit (mm)

Chain No.	Pitch	Roller Link Width W	Roller dia. D	Pin						Transvers e Pitch C	Plate			JIS Min. Tensile Strength		DID Min. Tensile Strength		DID Avg. Tensile Strength		DID Max. Allowable Load		Approx. Weight (kg/m)	
				d	E	G	L	e	g		T	H	h	kN	kgf	kN	kgf	kN	kgf	kN	kgf		
DID100	100				39.5	42.6	45.2							87	8,830	108	10,960	118	11,980	22.5	2,280	3.79	
DID100-2	100-2				75.3	78.3	81.1							174	17,660	216	21,930	236	23,960	38.3	3,890	7.53	
DID100-3	100-3	31.75	19.05	19.05	9.54	111.2	114.2	115.2	19.8	22.7	35.8	4.0	29.9	26.0	261	26,500	324	32,890	354	35,940	56.3	5,720	11.3
DID100-4	100-4					147.0	150.0	151.0							—	—	432	43,860	472	47,920	74.3	7,540	15.1
DID100-5	100-5					182.9	185.9	186.9							—	—	540	54,820	590	59,900	87.8	8,910	18.9

Note: The values of average tensile strength and Max. allowable tension are for chains.

Max. Kilowatt Ratings DID 100

Unit (kW)

No. of Teeth of Small Sprocket	Small Sprocket revolutions per minute (rpm) (See P132 for the details of type of lubrication A, B and C.)																										
	A			B											C												
11	1.17	2.67	4.99	9.31	17.4	25.0	32.4	35.8	35.8	29.9	24.4	20.5	17.5	15.2	13.3	11.8	10.6	9.51	8.64	7.24	6.18	5.35	4.70	4.42	4.17	1.08	
12	1.28	2.93	5.48	10.2	19.1	27.5	35.6	39.4	39.4	34.0	27.8	23.3	19.9	17.3	15.2	13.4	12.0	10.8	9.84	8.25	7.04	6.10	5.35	5.04	4.75	—	
13	1.40	3.20	5.97	11.2	20.8	30.0	38.9	42.9	42.9	38.4	31.4	26.3	22.5	19.5	17.1	15.2	13.6	12.2	11.1	9.30	7.94	6.88	6.04	5.68	5.35	—	
14	1.52	3.47	6.47	12.1	22.6	32.5	42.1	46.5	46.5	42.9	35.1	29.4	25.1	21.8	19.1	16.9	15.2	13.7	12.4	10.4	8.87	7.69	6.75	6.35	—	—	
15	1.63	3.73	6.97	13.0	24.3	35.0	45.3	50.1	50.1	47.5	38.9	32.6	27.8	24.1	21.2	18.8	16.8	15.2	13.8	11.5	9.84	8.53	7.48	7.04	—	—	
16	1.75	4.00	7.48	14.0	26.1	37.5	48.6	53.7	53.7	52.4	42.9	35.9	30.7	26.6	23.3	20.7	18.5	16.7	15.2	12.7	10.8	9.40	8.25	7.76	—	—	
17	1.87	4.28	7.98	14.9	27.8	40.1	51.9	57.4	57.4	57.4	47.0	39.4	33.6	29.1	25.6	22.7	20.3	18.3	16.6	13.9	11.9	10.3	9.03	—	—	—	
18	1.99	4.55	8.49	15.9	29.6	42.6	55.2	62.5	62.5	62.5	51.2	42.9	36.6	31.7	27.8	24.7	22.1	19.9	18.1	15.2	12.9	11.2	9.84	—	—	—	
19	2.11	4.82	9.00	16.8	31.4	45.2	58.5	67.8	67.8	67.8	55.5	46.5	39.7	34.4	30.2	26.8	24.0	21.6	19.6	16.4	14.0	12.2	10.7	—	—	—	
20	2.23	5.10	9.52	17.8	33.2	47.8	61.9	73.2	73.2	73.2	59.9	50.2	42.9	37.2	32.6	28.9	25.9	23.3	21.2	17.8	15.2	13.1	—	—	—	—	
21	2.35	5.37	10.0	18.7	34.9	50.3	65.2	78.8	78.8	78.8	64.5	54.0	46.1	40.0	35.1	31.1	27.8	25.1	22.8	19.1	16.3	14.1	—	—	—	—	
22	2.47	5.65	10.6	19.7	36.7	52.9	68.6	83.8	84.5	84.5	69.1	57.9	49.5	42.9	37.6	33.4	29.9	26.9	24.4	20.5	17.5	15.2	—	—	—	—	
23	2.60	5.93	11.1	20.7	38.6	55.5	71.9	88.0	90.3	90.3	73.9	61.9	52.9	45.8	40.2	35.7	31.9	28.8	26.1	21.9	18.7	16.2	—	—	—	—	
24	2.72	6.21	11.6	21.6	40.4	58.1	75.3	92.1	95.6	95.6	78.8	66.0	56.4	48.9	42.9	38.0	34.0	30.7	27.8	23.3	19.9	17.3	—	—	—	—	
25	2.84	6.49	12.1	22.6	42.2	60.8	78.7	96.2	100	100	83.7	70.2	59.9	51.9	45.6	40.2	36.2	32.6	29.6	24.8	21.2	18.3	—	—	—	—	
28	3.21	7.33	13.7	25.6	47.7	68.7	89.0	109	113	113	99.3	83.2	71.0	61.6	54.0	47.9	42.9	38.7	35.1	29.4	25.1	—	—	—	—	—	
30	3.46	7.90	14.8	27.5	51.4	74.0	95.9	117	122	122	110	92.2	78.8	68.3	59.9	53.1	47.5	42.9	38.9	32.6	—	—	—	—	—	—	
32	3.71	8.47	15.8	29.5	55.1	79.3	103	126	130	130	121	102	86.8	75.2	66.0	58.5	52.4	47.2	42.9	35.9	—	—	—	—	—	—	
35	4.09	9.33	17.4	32.5	60.7	87.4	113	138	147	147	139	116	99.3	86.0	75.5	67.0	59.9	54.0	49.0	—	—	—	—	—	—	—	
40	4.72	10.8	20.1	37.6	70.1	101	131	160	170	170	169	142	121	105	92.2	81.8	73.2	66.0	—	—	—	—	—	—	—	—	
45	5.36	12.2	22.9	42.7	79.6	115	149	182	194	194	194	169	145	125	110	97.6	—	—	—	—	—	—	—	—	—	—	

Note: 1. Values in the table above are for simplex chain only. For multiplex chains, please multiply the coefficient of multi-strand. (See "Chain Selection" on P120).
 2. Please consult with us when the ratings beyond the dotted line to rightward.

DID 120 standard roller chain

Roller Chains for Power Transmission

Standard Roller Chain

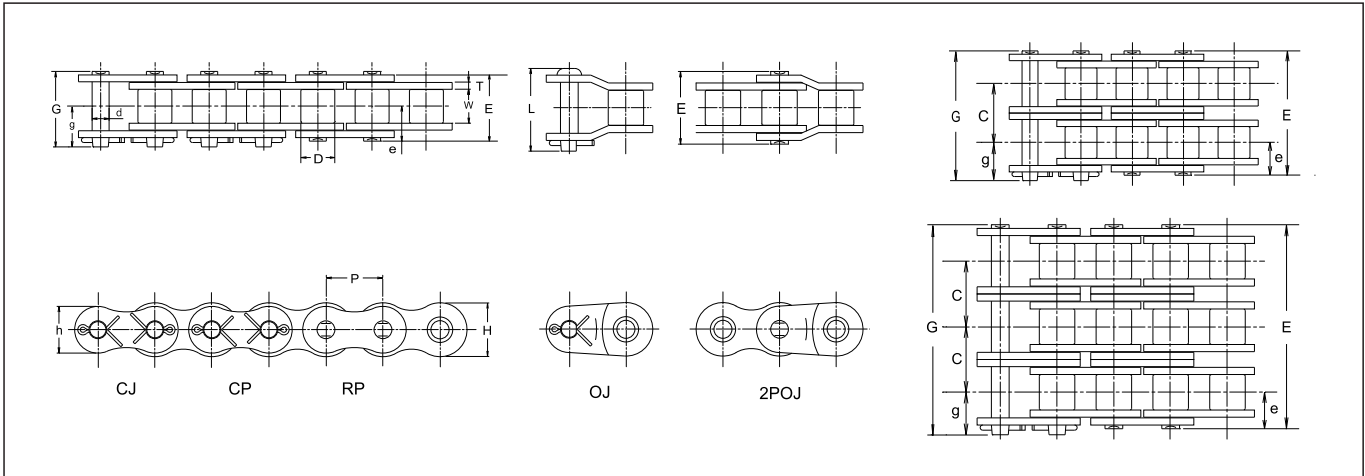

Dimensions

Unit (mm)

Chain No.	Pitch	Roller Link Width W	Roller dia. D	Pin						Transverse Pitch C	Plate			JIS		DID		DID		Approx. Weight (kg/m)			
				d	E	G	L	e	g		T	H	h	Min. Tensile Strength	Min. Tensile Strength	Avg. Tensile Strength	Max. Allowable Load						
DID	JIS	P												kN	kgf	kN	kgf	kN	kgf				
DID120	120				49.7	53.0	54.0							125	12,690	148	15,030	166	16,850	30.4	3,090	5.49	
DID120-2	120-2				95.2	98.5	99.6							250	25,380	296	30,050	332	33,710	51.7	5,250	11.0	
DID120-3	120-3	38.10	25.40	22.23	11.11	140.6	143.9	145.0	24.9	28.2	45.4	4.80	35.9	31.2	375	38,070	444	45,080	498	50,560	76	7,720	16.5
DID120-4	120-4					186.1	189.4	190.5							—	—	592	60,100	664	67,410	100	10,150	22.0
DID120-5	120-5					231.5	234.8	235.9							—	—	740	75,130	830	84,260	119	12,080	27.5

Note: The values of average tensile strength and Max. allowable tension are for chains.

Max. Kilowatt Ratings DID 120

Unit (kW)

No. of Teeth of Small Sprocket	Small Sprocket revolutions per minute (rpm) (See P132 for the details of type of lubrication A, B and C.)																										
	A			B								C															
Type of Lubrication	10	25	50	100	150	200	300	400	500	600	700	800	900	1000	1100	1200	1300	1400	1500	1600	1700	1800	1900	2000	2100		
11	1.90	4.33	8.09	15.1	21.8	28.2	40.6	51.2	43.5	34.5	28.3	23.7	20.2	17.5	15.4	13.7	12.2	11.0	9.99	9.12	8.37	7.72	7.15	6.64	—	—	
12	2.08	4.76	8.89	16.6	23.9	31.0	44.6	56.3	49.6	39.4	32.2	27.0	23.1	20.0	17.5	15.6	13.9	12.5	11.4	10.4	9.54	8.80	8.15	—	—	—	—
13	2.27	5.19	9.69	18.1	26.1	33.8	48.6	61.3	55.9	44.4	36.3	30.4	26.0	22.5	19.8	17.5	15.7	14.2	12.8	11.7	10.8	9.92	9.19	—	—	—	—
14	2.46	5.62	10.5	19.6	28.2	36.6	52.7	66.4	66.4	62.5	49.6	40.6	34.0	29.1	25.2	22.1	19.6	17.5	15.8	14.4	13.1	12.0	11.1	10.3	—	—	—
15	2.65	6.06	11.3	21.1	30.4	39.4	56.7	71.6	71.6	69.3	55.0	45.0	37.7	32.2	27.9	24.5	21.7	19.5	17.5	15.9	14.5	13.3	12.3	—	—	—	—
16	2.84	6.50	12.1	22.6	32.6	42.2	60.8	76.7	76.7	76.4	60.6	49.6	41.6	35.5	30.8	27.0	23.9	21.4	19.3	17.5	16.0	14.7	13.6	—	—	—	—
17	3.04	6.94	13.0	24.2	34.8	45.1	65.0	83.7	83.7	83.6	66.4	54.3	45.5	38.9	33.7	29.6	26.2	23.5	21.2	19.2	17.5	16.1	14.8	—	—	—	—
18	3.23	7.38	13.8	25.7	37.0	48.0	69.1	89.5	91.2	91.1	72.3	59.2	49.6	42.4	36.7	32.2	28.6	25.6	23.1	20.9	19.1	17.5	16.2	—	—	—	—
19	3.43	7.82	14.6	27.3	39.3	50.9	73.3	94.9	98.9	98.8	78.4	64.2	53.8	45.9	39.8	34.9	31.0	27.7	25.0	22.7	20.7	19.0	—	—	—	—	—
20	3.62	8.27	15.4	28.8	41.5	53.8	77.4	100	107	107	84.7	69.3	58.1	49.6	43.0	37.7	33.5	29.9	27.0	24.5	22.4	20.5	—	—	—	—	—
21	3.82	8.72	16.3	30.4	43.7	56.7	81.6	106	115	115	91.1	74.6	62.5	53.4	46.3	40.6	36.0	32.2	29.1	26.4	24.1	22.1	—	—	—	—	—
22	4.01	9.16	17.1	31.9	46.0	59.6	85.8	111	123	123	97.7	80.0	67.0	57.2	49.6	43.5	38.6	34.5	31.2	28.3	25.8	23.7	—	—	—	—	—
23	4.21	9.62	18.0	33.5	48.3	62.5	90.0	117	132	132	104	85.5	71.7	61.2	53.0	46.5	41.3	36.9	33.3	30.2	27.6	—	—	—	—	—	—
24	4.41	10.1	18.8	35.1	50.5	65.5	94.3	122	140	140	111	91.1	76.4	65.2	56.5	49.6	44.0	39.4	35.5	32.2	29.4	—	—	—	—	—	—
25	4.61	10.5	19.6	36.7	52.8	68.4	98.5	128	146	146	118	96.9	81.2	69.3	60.1	52.7	46.8	41.9	37.7	34.3	31.3	—	—	—	—	—	—
28	5.21	11.9	22.2	41.4	59.7	77.3	111	144	165	165	140	115	96.2	82.2	71.2	62.5	55.4	49.6	44.7	40.6	—	—	—	—	—	—	—
30	5.61	12.8	23.9	44.6	64.3	83.3	120	155	178	178	156	127	107	91.1	79.0	69.3	61.5	55.0	49.6	—	—	—	—	—	—	—	—
32	6.02	13.7	25.6	47.9	68.9	89.3	129	167	191	191	171	140	118	100	87.0	76.4	67.7	60.6	—	—	—	—	—	—	—	—	—
35	6.63	15.1	28.3	52.7	75.9	98.4	142	184	211	211	196	160	135	115	99.5	87.4	77.5	—	—	—	—	—	—	—	—	—	—
40	7.66	17.5	32.6	60.9	87.7	114	164	212	246	246	240	196	164	140	122	—	—	—	—	—	—	—	—	—	—	—	—
45	8.70	19.9	37.1	69.2	99.6	129	186	241	286	286	286	234	196	167	—	—	—	—	—	—	—	—	—	—	—	—	—

Note: 1. Values in the table above are for simplex chains only. For multiplex chains, please multiply the coefficient of multi-strand. (See "Chain Selection" on P120).
 2. Consult us when the ratings beyond the dotted line to rightward.

DID 140 standard roller chain

Roller Chains for Power Transmission

Standard Roller Chain

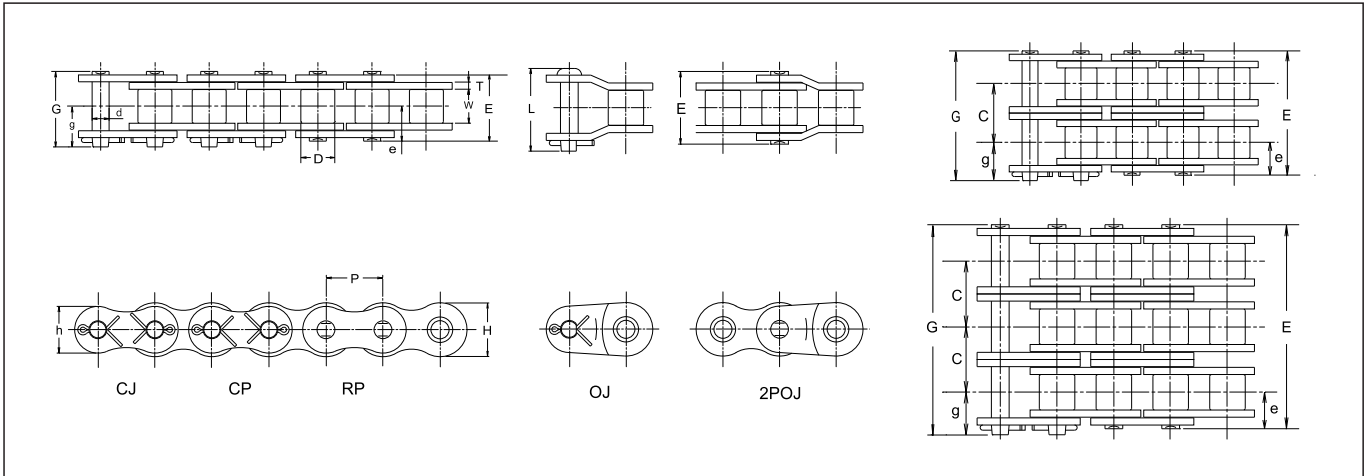

Dimensions

Unit (mm)

Chain No.	Pitch	Roller Link Width W	Roller dia. D	Pin						Transvers e Pitch C	Plate			JIS		DID		DID		Approx. Weight (kg/m)			
				d	E	G	L	e	g		T	H	h	Min. Tensile Strength	Min. Tensile Strength	Avg. Tensile Strength	Max. Allowable Load						
DID	JIS	P												kN	kgf	kN	kgf	kN	kgf				
DID140	140				53.6	58.4	59.6							170	17,260	193	19,590	215	21,830	40.2	4,080	7.11	
DID140-2	140-2				102.6	107.4	108.6							340	34,520	386	39,190	430	43,650	68.3	6,930	14.1	
DID140-3	140-3	44.45	25.40	25.40	12.71	151.5	156.3	157.5	26.8	31.7	48.9	5.60	41.9	36.3	510	51,780	579	58,780	645	65,480	101	10,250	21.1
DID140-4	140-4					200.5	205.3	206.5							—	—	772	78,380	860	87,310	133	13,500	28.1
DID140-5	140-5					249.4	254.2	255.4							—	—	965	97,970	1,075	109,140	157	15,940	34.9

Note: The values of average tensile strength and Max. allowable tension are for chains.

Max. Kilowatt Ratings DID 140

Unit (kW)

No. of Teeth of Small Sprocket	Small Sprocket revolutions per minute (rpm) (See P132 for the details of type of lubrication A, B and C.)																									
	A			B											C											
Type of Lubrication	10	25	50	100	150	200	250	300	350	400	450	500	550	600	700	800	900	1000	1100	1200	1300	1400	1500	1600	1650	
11	2.93	6.69	12.5	23.3	33.6	43.5	53.2	62.6	72.0	72.7	64.7	56.1	49.3	39.1	32.0	26.8	22.9	19.8	17.4	15.4	13.8	12.5	11.3	10.8		
12	3.22	7.35	13.7	25.6	36.9	47.8	58.4	68.8	79.0	79.9	73.8	63.9	56.1	44.5	36.4	30.5	26.1	22.6	19.8	17.6	15.7	14.2	12.9	12.3		
13	3.51	8.01	15.0	27.9	40.2	52.1	63.7	75.0	86.2	87.1	83.2	72.1	63.3	50.2	41.1	34.4	29.4	25.5	22.4	19.8	17.8	16.0	14.5	—		
14	3.80	8.68	16.2	30.2	43.5	56.4	69.0	81.3	93.4	94.4	93.0	80.6	70.7	56.1	45.9	38.5	32.9	28.5	25.0	22.2	19.8	17.9	16.2	—		
15	4.10	9.35	17.5	32.6	46.9	60.8	74.3	87.6	101	103	103	89.4	78.4	62.2	50.9	42.7	36.4	31.6	27.7	24.6	22.0	19.8	5.75	—		
16	4.39	10.0	18.7	34.9	50.3	65.2	79.7	93.9	108	114	114	114	98.4	86.4	68.6	56.1	47.0	40.2	34.8	30.5	27.1	24.2	21.9	—		
17	4.69	10.7	20.0	37.3	53.7	69.6	85.1	100	115	124	124	124	108	94.6	75.1	61.5	51.5	44.0	38.1	33.5	29.7	26.5	23.9	—		
18	4.99	11.4	21.3	39.7	57.1	74.0	90.5	107	122	136	136	136	117	103	81.8	67.0	56.1	47.9	41.5	36.4	32.3	28.9	26.1	—		
19	5.29	12.1	22.5	42.0	60.6	78.5	95.9	113	130	144	144	144	127	112	88.7	72.6	60.9	52.0	45.0	39.5	35.1	31.4	28.3	—		
20	5.59	12.8	23.8	44.4	64.0	82.9	101	119	137	152	152	152	138	121	95.8	78.4	65.7	56.1	48.6	42.7	37.9	33.9	5.68	—		
21	5.89	13.5	25.1	46.8	67.5	87.4	107	126	145	161	161	161	148	130	103	84.4	70.7	60.4	52.3	45.9	40.7	36.4	—			
22	6.20	14.1	26.4	49.3	71.0	91.9	112	132	152	169	169	169	159	139	111	90.5	75.8	64.7	56.1	49.3	43.7	39.1	—			
23	6.50	14.8	27.7	51.7	74.4	96.4	118	139	160	177	177	177	170	149	118	96.7	81.1	69.2	60.0	52.6	46.7	41.8	—			
24	6.81	15.5	29.0	54.1	77.9	101	123	145	167	186	186	186	181	159	126	103	86.4	73.8	63.9	56.1	49.8	44.2	—			
25	7.11	16.2	30.3	56.6	81.5	106	129	152	175	194	194	194	192	169	134	110	91.9	78.4	68.0	59.7	52.9	47.5	—			
30	8.66	19.8	36.9	68.9	99.2	128	157	185	213	240	253	253	253	222	176	144	121	103	89.4	—	—	—	—	—		
32	9.29	21.2	39.6	73.8	106	138	168	198	228	257	276	276	276	244	194	159	133	114	98.4	—	—	—	—	—		
35	10.2	23.4	43.6	81.3	117	152	186	219	251	283	304	304	304	280	222	182	152	130	—	—	—	—	—	—		
40	11.8	27.0	50.3	94.0	135	175	214	253	290	327	351	351	351	342	271	222	—	—	—	—	—	—	—	—		
45	13.4	30.6	57.2	107	154	199	243	287	329	372	408	408	408	408	323	—	—	—	—	—	—	—	—	—	—	

Note: 1. Values in the table above are for simplex chains only. For multiplex chains, please multiply the coefficient of multi-strand. (See "Chain Selection" on P120).

2. Consult us when the ratings beyond the dotted line to rightward.

DID 160 standard roller chain

Roller Chains for Power Transmission

Standard Roller Chain

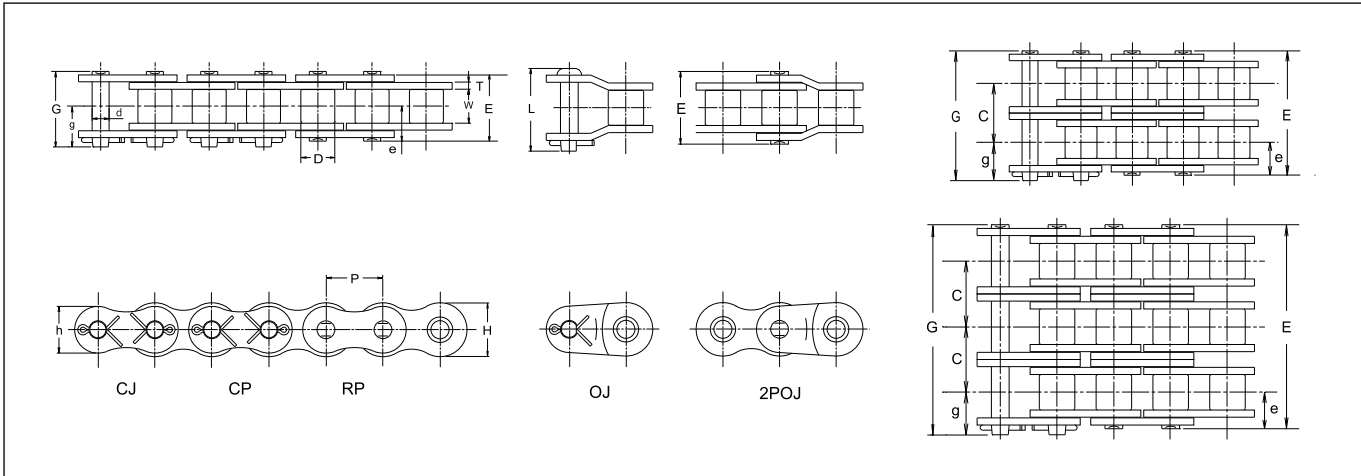

Dimensions

Unit (mm)

Chain No.	Pitch	Roller Link Width W	Roller dia. D	Pin						Transverse Pitch C	Plate			JIS Min. Tensile Strength		DID Min. Tensile Strength		DID Avg. Tensile Strength		DID Max. Allowable Load		Approx. Weight (kg/m)	
				d	E	G	L	e	g		T	H	h	kN	kgf	kN	kgf	kN	kgf	kN	kgf		
DID160	160				63.6	68.2	69.7								223	22,640	245	24,870	269	27,310	52.9	5,370	9.82
DID160-2	160-2				122.2	126.8	128.3								446	45,280	490	49,750	538	54,620	89.9	9,130	19.4
DID160-3	160-3	50.80	31.75	28.58	14.29	180.8	185.4	186.9	31.9	36.5	58.5	6.40	47.8	41.4	669	67,920	735	74,620	807	81,930	132	13,400	29.0
DID160-4	160-4					239.3	243.8	245.4							—	—	980	99,490	1,076	109,240	175	17,770	38.6
DID160-5	160-5					297.8	303.4	303.9							—	—	1,225	124,370	1,345	136,550	206	20,910	48.2

Note: The values of average tensile strength and Max. allowable tension are for chains.

Max. Kilowatt Ratings DID 160

Unit (kW)

No. of Teeth of Small Sprocket	Small Sprocket revolutions per minute (rpm) (See P132 for the details of type of lubrication A, B and C.)																							
	A			B						C														
Type of Lubrication	10	25	50	100	150	200	250	300	350	400	450	500	550	600	650	700	750	800	850	900	1000	1100	1200	1300
11	4.41	10.1	18.8	35.0	50.5	65.4	79.9	94.2	98.5	98.5	84.4	72.0	62.4	54.8	48.6	43.5	39.2	35.6	32.5	29.8	25.5	22.1	19.4	17.2
12	4.84	11.1	20.6	38.5	55.4	71.8	87.8	103	108	108	96.1	82.1	71.1	62.4	55.4	49.6	44.7	40.6	37.0	34.0	29.0	25.2	22.1	19.6
13	5.28	12.1	22.5	42.0	60.5	78.3	95.7	113	118	118	108	92.6	80.2	70.4	62.4	55.9	50.4	45.7	41.8	38.3	32.7	28.4	24.9	22.1
14	5.72	13.1	24.4	45.5	65.5	84.8	104	122	128	128	121	103	89.7	78.7	69.8	62.4	56.3	51.1	46.7	42.8	36.6	31.7	27.8	24.7
15	6.16	14.1	26.3	49.0	70.6	91.4	112	132	138	138	134	115	99.4	87.3	77.4	69.3	62.4	56.7	51.8	47.5	40.6	35.2	30.9	14.7
16	6.61	15.1	28.1	52.5	75.7	98.0	120	141	148	148	148	126	110	96.1	85.3	76.3	68.8	62.4	57.0	52.3	44.7	38.7	34.0	—
17	7.05	16.1	30.1	56.1	80.8	105	128	151	162	162	162	138	120	105	93.4	83.6	75.3	68.4	62.4	57.3	48.9	42.4	37.2	—
18	7.50	17.1	32.0	59.6	85.9	111	136	160	177	177	177	151	131	115	102	91.0	82.1	74.5	68.0	62.4	53.3	46.2	40.6	—
19	7.96	18.2	33.9	63.2	91.1	118	144	170	192	192	192	164	142	124	110	98.7	89.0	80.8	73.8	67.7	57.8	50.1	44.0	—
20	8.41	19.2	35.8	66.8	96.3	125	152	180	206	207	207	177	153	134	119	107	96.1	87.3	79.7	73.1	62.4	54.1	47.5	—
21	8.86	20.2	37.8	70.5	101	131	161	189	218	220	220	190	165	145	128	115	103	93.9	85.7	78.7	67.2	58.2	25.9	—
22	9.32	21.3	39.7	74.1	107	138	169	199	229	231	231	204	177	155	137	123	111	101	91.9	84.4	72.0	62.4	—	—
24	10.2	23.4	43.6	81.4	117	152	186	219	251	254	254	232	201	177	157	140	126	115	105	96.1	82.1	71.1	—	—
25	10.7	24.4	45.6	85.0	123	159	194	229	263	266	266	247	214	188	167	149	134	122	111	102	87.3	75.6	—	—
30	13.0	29.7	55.5	104	149	193	236	278	320	330	330	324	281	247	219	196	177	160	146	134	—	—	—	—
32	14.0	31.9	59.5	111	160	207	253	298	343	358	358	357	310	272	241	216	195	177	161	—	—	—	—	—
35	15.4	35.1	65.5	122	176	228	279	329	378	409	409	409	354	311	276	247	223	—	—	—	—	—	—	—
40	17.8	40.6	75.7	141	204	264	322	380	436	467	467	467	433	380	337	—	—	—	—	—	—	—	—	—
45	20.2	46.1	86.0	160	231	299	366	431	495	532	532	532	517	453	—	—	—	—	—	—	—	—	—	—

Note: 1. Values in the table above are for simplex chains only. For multiplex chains, please multiply the coefficient of multi-strand. (See "Chain Selection" on P120).

2. Consult us when the ratings beyond the dotted line to rightward.

DID 180 standard roller chain

Roller Chains for Power Transmission

Standard Roller Chain

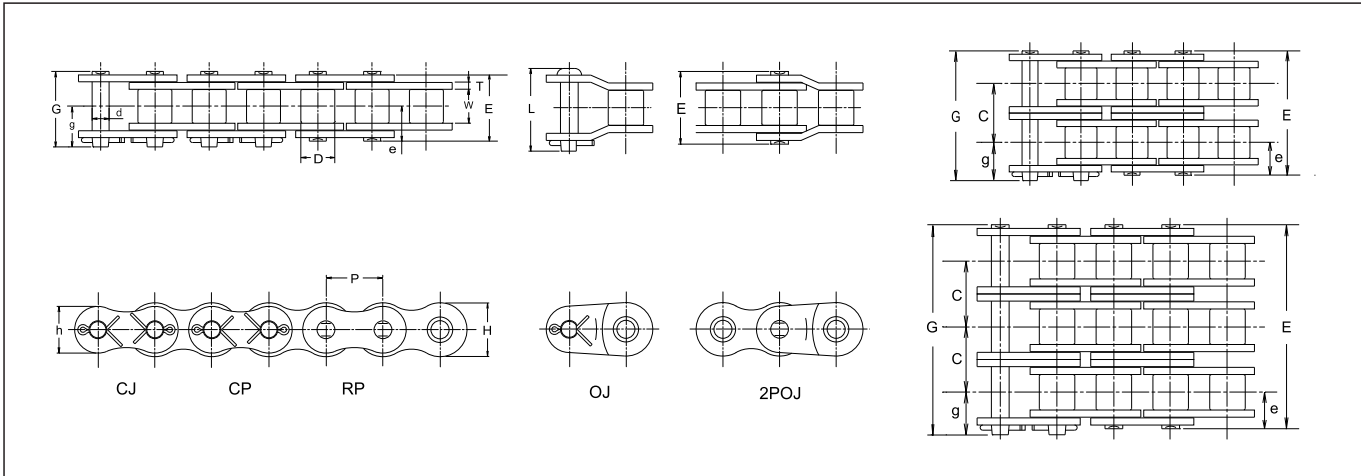

Dimensions

Unit (mm)

Chain No.	Pitch	Roller Link Width	Roller dia.	Pin						Transverse Pitch	Plate			JIS		DID		DID		Approx. Weight (kg/m)			
				d	E	G	L	e	g		C	T	H	h	Min. Tensile Strength	Min. Tensile Strength	Avg. Tensile Strength	Max. Allowable Load					
DID	JIS	P	W	D	d	E	G	L	e	g	C	T	H	h	kN	kgf	kN	kgf	kN	kgf			
DID180	180					71.5	77.3	79.3							281	28,530	333	33,810	362	36,750	61.7	6,260	12.7
DID180-2	180-2					137.4	143.2	145.2							562	57,060	666	67,610	724	73,500	105	10,660	25.0
DID180-3	180-3	57.15	35.72	35.71	17.46	203.3	209.1	211.1	35.8	41.6	65.8	7.10	53.8	46.6	843	85,580	999	101,420	1,086	110,250	154	15,630	37.3
DID180-4	180-4					269.1	274.9	276.9							—	—	1,332	135,230	1,448	147,010	204	20,710	49.6
DID180-5	180-5					334.9	340.7	342.7							—	—	1,665	169,040	1,810	183,760	241	24,470	61.9

Note: The values of average tensile strength and Max. allowable tension are for chains.

Max. Kilowatt Ratings DID 180

Unit (kW)

No. of Teeth of Small Sprocket	Small Sprocket revolutions per minute (rpm) (See P132 for the details of type of lubrication A, B and C.)																																																																																																																																																																																																																																																																																																																																																																																																				
	10			25			50			100			150			200			250			300			350			400			450			500			550			600			650			700			750			800			850			900			950			1000			1050			1100																																																																																																																																																																																																																																																																																																																															
Type of Lubrication	A						B						C																																																																																																																																																																																																																																																																																																																																																																																								
13	6.93	15.8	29.5	55.1	79.3	103	126	142	142	142	119	102	88.2	77.4	68.6	61.4	55.4	50.3	45.9	42.1	38.8	36.0	33.4	15.0	7.51	17.1	32.0	59.7	85.9	111	136	159	159	159	133	114	98.5	86.5	76.7	68.6	61.9	56.2	51.3	47.1	43.4	40.2	37.3	—	8.09	18.5	34.4	64.3	92.6	120	147	173	176	176	148	126	109	95.9	85.0	76.1	68.6	62.3	56.9	52.2	48.1	44.6	41.4	—	8.67	19.8	36.9	68.9	99.3	129	157	185	191	191	163	139	120	106	93.7	83.8	75.6	68.6	62.6	57.5	53.0	49.1	38.3	—	9.26	21.1	39.4	73.6	106	137	168	198	201	201	178	152	132	116	103	91.8	82.8	75.1	68.6	63.0	58.1	53.8	9.66	—	9.85	22.5	41.9	78.3	113	146	179	210	216	216	194	166	144	126	112	100	90.2	81.9	74.8	68.6	63.3	58.6	—	—	10.4	23.8	44.5	83.0	120	155	189	223	229	229	210	180	156	137	121	108	97.8	88.8	81.1	74.4	68.6	63.5	—	—	11.0	25.2	47.0	87.7	126	164	200	236	243	243	227	194	168	148	131	117	106	95.9	87.6	80.4	74.1	38.4	—	—	11.6	26.5	49.5	92.4	133	173	211	248	256	256	245	209	181	159	141	126	114	103	94.2	86.5	79.7	—	—	—	12.2	27.9	52.1	97.2	140	181	222	261	269	269	262	224	194	170	151	135	122	111	101	92.7	85.5	—	—	—	13.4	30.7	57.2	107	154	199	244	287	299	299	299	255	221	194	172	154	139	126	115	—	—	—	—	—	14.7	33.4	62.4	116	168	217	266	313	339	339	337	288	249	219	194	174	—	—	—	—	—	—	—	—	—	17.1	39.0	72.8	136	196	254	310	365	402	402	402	357	309	271	241	—	—	—	—	—	—	—	—	—	—	20.2	46.1	86.0	160	231	300	366	431	478	478	478	449	389	—	—	—	—	—	—	—	—	—	—	—	—	23.3	53.2	99.4	185	267	346	423	498	559	559	559	549	—	—	—	—	—	—	—	—	—	—	—	—	—	26.5	60.5	113	211	303	393	480	566	635	635	635	—	—	—	—	—	—	—	—	—	—	—	—	—	—

Note: 1. Values in the above table are for simplex chain only. For multiplex chains, please multiply the coefficient of multi-strand. (See "Chain Selection" on P120.).

2. Consult us when the ratings beyond the dotted line to rightward.

DID 200 standard roller chain

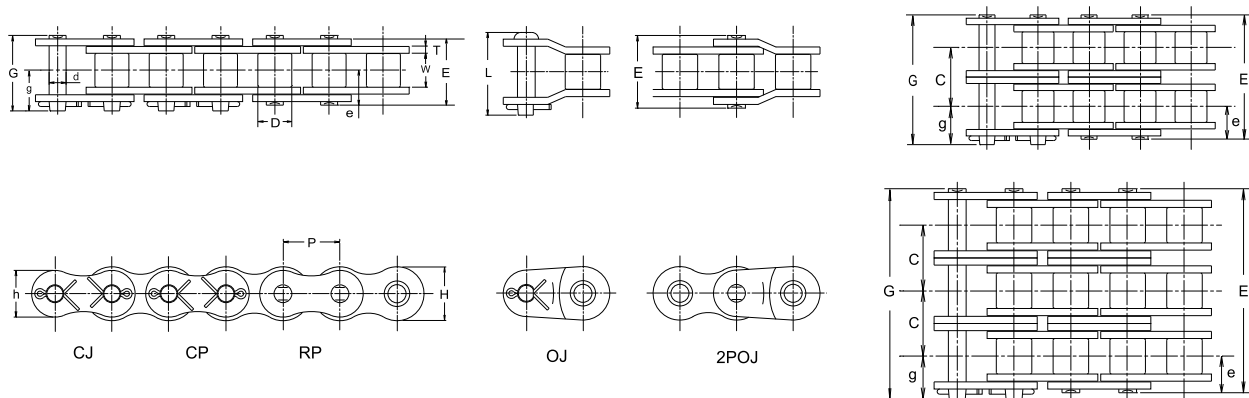

Dimensions

Chain No.		Pitch P	Roller Link Width W	Roller dia. D	Pin						Transverse Pitch C	Plate				JIS		DID		DID		Approx. Weight (kg/m)	
DID	JIS				d	E	G	L	e	g		T	H	h	Min. Tensile Strength		Min. Tensile Strength		Avg. Tensile Strength		Max. Allowable Load		
															kN	kgf	kN	kgf	kN	kgf	kN		kgf
DID200	200					77.9	85.0	87.3							347	35,230	431	43,760	470	47,720	73.5	7,460	16.5
DID200-2	200-2					149.6	156.6	159.0							694	70,460	863	87,610	940	95,430	125	12,690	32.5
DID200-3	200-3	63.50	38.10	39.68	19.85	221.3	228.3	230.6	39.0	46.0	71.6	8.00	60.0	52.0	1,041	105,690	1,294	131,370	1,410	143,150	184	18,680	48.5
DID200-4	200-4					292.9	299.9	302.2							—	—	1,725	175,130	1,880	190,860	243	24,670	64.5
DID200-5	200-5					364.5	371.5	373.8							—	—	2,157	218,980	2,350	238,580	287	29,140	80.5

Note: The values of average tensile strength and Max. allowable tension are for chains.

Max. Kilowatt Ratings DID 200

No. of Teeth of Small Sprocket	Type of Lubrication	Small Sprocket revolutions per minute (rpm) (See P132 for the details of type of lubrication A, B and C.)																								
		10					15					20					30					40				
		A					B					C					C									
13		9.60	13.8	17.9	25.8	33.5	40.9	48.2	62.4	76.3	110	142	172	172	172	155	130	95.9	84.2	74.6	66.8	60.2	54.7	49.9	45.8	
14		10.4	15.0	19.4	28.0	36.2	44.3	52.2	67.6	82.7	119	154	187	187	187	173	145	107	94.1	83.4	74.6	67.3	61.1	55.8	30.2	
15		11.2	16.2	20.9	30.1	39.0	47.7	56.2	72.9	89.1	128	166	201	201	201	192	161	119	104	92.5	82.8	74.6	67.8	61.9	1.57	
16		12.0	17.3	22.4	32.3	41.9	51.2	60.3	78.1	95.5	138	178	216	216	216	211	177	131	115	102	91.2	82.2	74.6	68.2	—	
17		12.8	18.5	24.0	34.5	44.7	54.6	64.4	83.4	102	147	190	231	231	231	231	194	143	126	112	99.9	90.1	81.8	74.6	—	
18		13.7	19.7	25.5	36.7	47.5	58.1	68.5	88.7	108	156	202	247	252	252	252	211	156	137	122	109	98.1	89.1	53.1	—	
19		14.5	20.8	27.0	38.9	50.4	61.6	72.6	94.1	115	166	215	262	273	273	273	229	169	149	132	118	106	96.6	—	—	
20		15.3	22.0	28.5	41.1	53.3	65.1	76.7	99.4	122	175	227	277	293	293	293	247	183	161	142	127	115	—	—	—	
21		16.1	23.2	30.1	43.3	56.2	68.6	80.9	105	128	185	239	292	317	317	317	266	197	173	153	137	—	—	—	—	
22		17.0	24.4	31.6	45.6	59.0	72.2	85.1	110	135	194	251	307	340	340	340	285	211	185	164	147	—	—	—	—	
24		18.6	26.8	34.8	50.1	64.9	79.3	93.4	121	148	213	276	338	377	377	377	325	241	211	187	—	—	—	—	—	
26		20.3	29.3	37.9	54.6	70.7	86.5	102	132	161	232	301	368	408	408	408	367	271	238	—	—	—	—	—	—	

Note: 1. Value in the above table is for simplex chain only. For multiplex chains, please apply the coefficient of Multi-strand. (Please refer to Chain selection on P.120).

2. Consult us when the ratings beyond the dotted line to rightward.

DID 240 standard roller chain

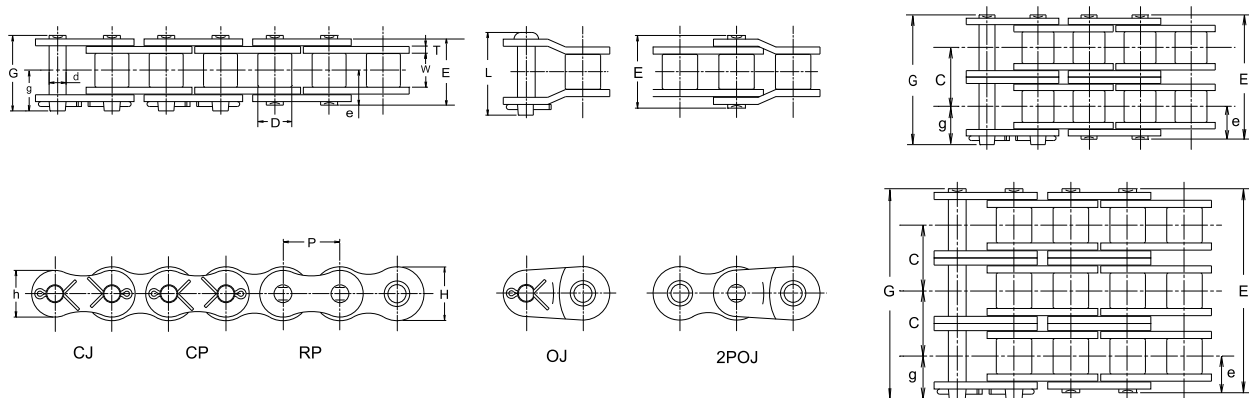

Dimensions

Chain No.		Pitch P	Roller Link Width W	Roller dia. D	Pin						Transvers e Pitch C	Plate				JIS		DID		DID		Approx. Weight (kg/m)	
DID	JIS				d	E	G	L	e	g		T	H	h	Min. Tensile Strength		Min. Tensile Strength		Avg. Tensile Strength		Max. Allowable Load		
															kN	kgf	kN	kgf	kN	kgf	kN		kgf
DID240	240					95.2	102.9	105.4							500	50,760	623	63,250	686	69,640	99	10,050	23.3
DID240-2	240-2					183.1	190.7	193.3							1,000	101,520	1,246	126,500	1,372	139,290	168	17,060	46.0
DID240-3	240-3	76.20	47.63	47.63	23.81	270.9	278.5	281.1	47.7	55.3	87.8	9.50	71.5	62.0	1,500	152,280	1,869	189,750	2,058	208,930	248	25,180	68.7
DID240-4	240-4					358.7	366.4	368.9							—	—	2,492	252,990	2,744	278,580	327	33,200	91.3
DID240-5	240-5					446.5	454.2	456.7							—	—	3,115	316,240	3,430	348,220	386	39,190	114

Note: The values of average tensile strength and Max. allowable tension are for chains.

Max. Kilowatt Ratings DID 240

No. of Teeth of Small Sprocket	Small Sprocket revolutions per minute (rpm) (See P132 for the details of type of lubrication A, B and C.)																																																
	5						10						15						20						25																								
	A						B						C						C						C																								
13	7.78	14.5	20.9	27.1	33.1	39.1	50.6	61.9	72.9	94.4	115	141	166	191	215	242	242	219	179	150	128	111	97.4	15.7	8.43	15.7	22.7	29.4	35.9	42.3	54.8	67.0	79.0	102	125	153	180	207	233	263	263	244	200	168	143	124	109	—	
14	9.08	17.0	24.4	31.7	38.7	45.6	59.1	72.2	85.1	110	135	165	194	223	251	283	283	271	222	186	159	138	121	—	9.74	18.2	26.2	33.9	41.5	48.9	63.3	77.4	91.2	118	144	177	208	239	270	302	302	298	244	205	175	152	130	—	
15	10.4	19.4	28.0	36.2	44.3	52.2	67.6	82.6	97.4	126	154	189	222	255	288	327	327	327	268	224	191	166	101	—	11.1	20.7	29.7	38.5	47.1	55.5	71.9	87.9	104	134	164	201	236	271	306	356	356	356	291	244	209	181	72.6	—	
16	11.7	21.9	31.5	40.9	49.9	58.8	76.2	93.2	110	142	174	213	251	288	325	386	386	386	316	265	226	196	44.0	—	12.4	23.1	33.3	43.2	52.8	62.2	80.6	98.5	116	150	184	225	265	304	343	417	417	417	341	286	244	212	15.3	—	
17	13.1	24.4	35.1	45.5	55.6	65.6	84.9	104	122	159	194	237	279	321	362	442	449	449	367	308	263	204	—	—	13.7	25.7	36.9	47.9	58.5	68.9	89.3	109	129	167	204	249	293	337	380	465	481	481	394	330	282	176	—	—	
18	15.1	28.2	40.6	52.6	64.3	75.7	98.1	120	141	183	224	274	322	370	418	511	511	538	538	449	376	321	—	—	16.5	30.7	44.3	57.3	70.1	82.6	107	131	154	200	244	298	352	404	455	557	582	582	506	424	299	—	—	—	
19																																																	
20																																																	
21																																																	
22																																																	
23																																																	
24																																																	
25																																																	
26																																																	

Note: 1. Values in the above table are for simplex chain only. For multiplex chains, please multiply the coefficient of multi-strand. (See "Chain Selection" on P120).

2. Consult us when the ratings beyond the dotted line to rightward.