

**LAMIDISC® STEEL
DISC COUPLING**



EXPERIENCE,
INNOVATION AND
CLOSE COOPERATION
WITH LEADING
INTERNATIONAL
COMPANIES.

JAURE® COUPLINGS AND POWER TRANSMISSION SOLUTIONS

We are a leading supplier of couplings and power transmission solutions. Experience, manufacturing expertise, innovation and close cooperation with leading international companies enable us to provide customized solutions to our customers

For over 50 years, we have developed couplings for the most demanding applications in marine, wind, energy, steel, railway and paper industries among others.

We have a broad range of manufacturing capabilities, particularly with respect to power and speed. We continue developing new products for future challenges.

The integration of Kop-Flex® and Jaure coupling products has added to our ability to apply technical expertise in providing answers, products and services to our customers for their many varied applications globally.

LAMIDISC® DISC PACK COUPLING INTRODUCTION

Jaure® LAMIDISC® disc pack coupling

We launched the LAMIDISC® disc pack coupling back in the 90s as an alternative to gear couplings. Thousands of LAMIDISC couplings have been successfully operating since then.

LAMIDISC coupling is a torsionally stiff coupling with no need for greasing. This fact reduces downtime for maintenance. Also, it is backlash free, which makes it optimal for certain applications, such as pulp and paper, pumps, marine, cooling towers, etc.

F: Single Disc Angular Case FEA_78mm_Disc_Orientation_B_1_Deg
Total Deformation
Type: Total Deformation
Unit: mm
Time: 1

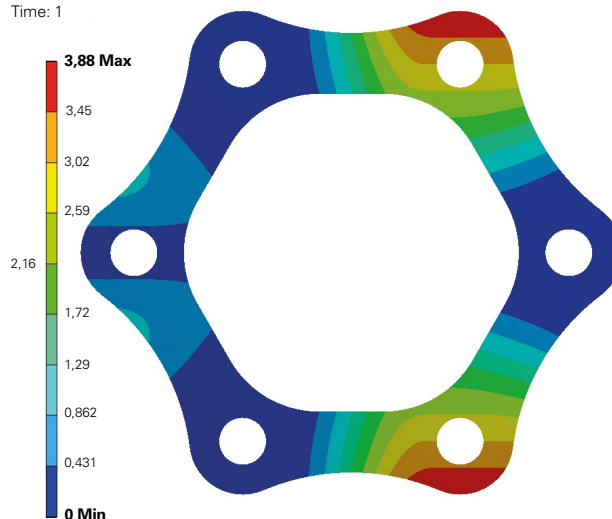

Disc finite elements analysis (FEA)

The flexible element is the disc pack. It is composed of a number of stainless steel discs assembled together. In-house testing, supported by finite element analysis, was performed to optimize the disc pack profile. As a result of this testing, the Jaure disc pack design offers one of the highest torque capacities in the industry.

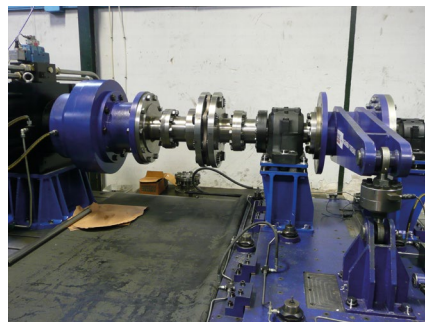

Main advantages of LAMIDISC® couplings

- 6, 8 and 10 bolts design available.
- DOM range available for quick assembly.
- Wide range with no size limits.
- Torsionally rigid and backlash-free.
- Superior disc pack profile.
- Maintenance free. No need to grease.
- No need to disassemble the coupling to inspect. Discs can be checked during operation by using a strobe light.
- If properly aligned and used within specification, it should outlive the machine in which it is installed.
- Spare disc packs available in stock for immediate delivery.

Industry Applications

Test Bench

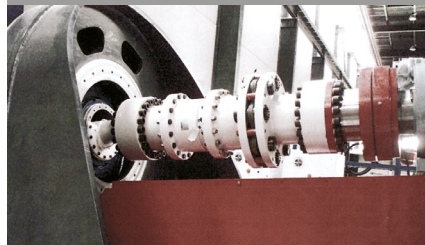

Pulp & Paper



Marine

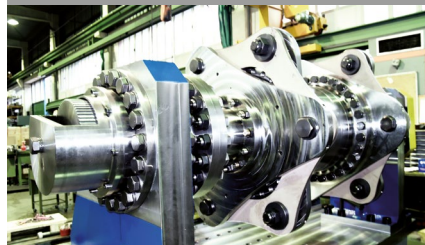

Winches



Wind



Cooling Towers



Cranes and hoisting



Mining

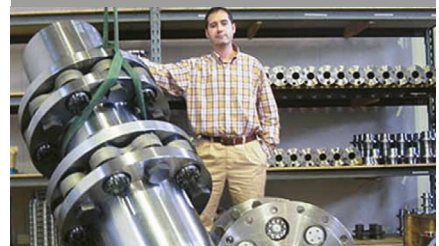

LAMIDISC® DISC PACK COUPLING INTRODUCTION



Marine Type Approval & Manufacturing Survey Arrangement

The Jaure® LAMIDISC® couplings can be delivered on demand with the 3.2 certificate of any Marine Classification Society.

We have been awarded the Manufacturing Survey Arrangement – MSA from DNV. The MSA certificate shows our commitment to continuously improve the service and response time to our customers and remain competitive in the industry.

Use in explosive areas

LAMIDISC® couplings are suitable for power transmission in hazardous areas. They are certified according to EC Directive 94/9/EC (ATEX 95) and are suitable for potentially explosive atmospheres GROUP II (categories 2G/2D). In case of any other particular need, please contact the Jaure® coupling engineering department.

Lamidisc® drive shafts

We provide turn-key solutions rather than just couplings. With this aim, we offer LAMIDISC couplings in combination with steel or composite drive shafts and other components such as JS nuts, bearings, expansion bolts, etc.

Steel drive shafts

JSSS: Jaure® Steel Solid Shafts

JSHS: Jaure Steel Hollow Shafts



Composite drive shafts

JCFS: Jaure® Carbon Fiber Shafts

JGFS: Jaure Glass Fiber Shafts

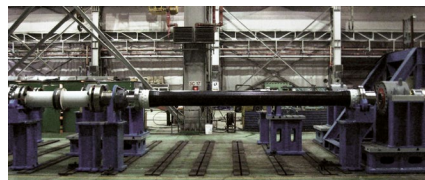

Composite drive shafts offer great features such us:

- Low weight.
- Corrosion resistance.
- No maintenance.
- Less number of bearings than in conventional drives.
- High misalignment capacity.
- Fire protection available on demand (FP).
- Electrical insulation (JGFS).

Jaure® JS Nuts

The Jaure Super Nut is a pretensioning device which has multiple screws located on a common pitch circle diameter that are intended to create an axial thrust by applying a small input torque.

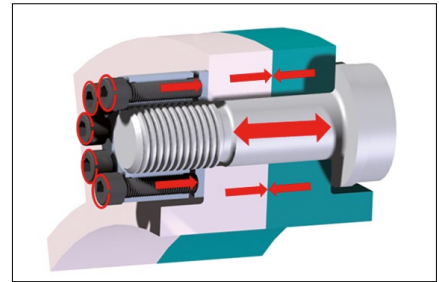
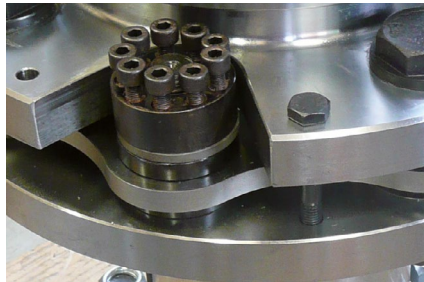

Jaure® LAMILINK couplings

Due to our commitment to continuous development and innovation, the Jaure coupling engineering department recently developed a NEW steel link coupling: LAMILINK Coupling.

It complements the current LAMIDISC® disc pack coupling offering and is specially suitable for those applications with higher misalignment requirements.

▸ Main features:

- High misalignment capacity.
- High torque range.
- Maintenance free.
- Light weight.
- Easy to handle.
- Coated links available.
- Long life if properly aligned.
- Low axial stiffness.

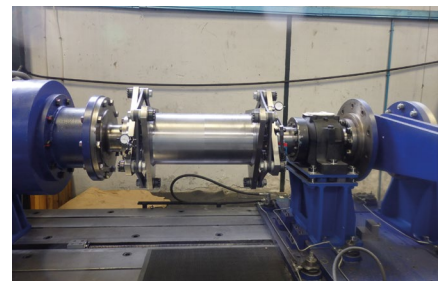
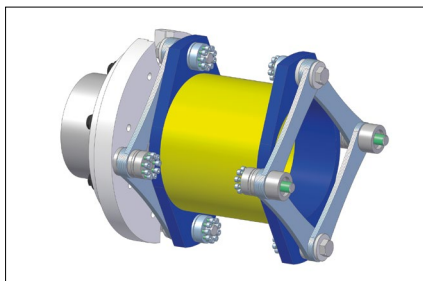

In house testing LAMILINK coupling ML-656-6





For further information, please contact Jaure coupling engineering department.

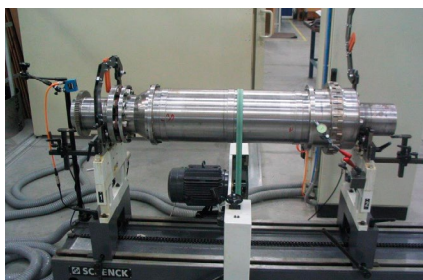

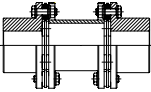
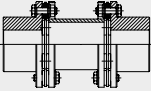
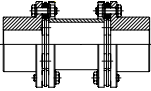

Disc couplings for high performance

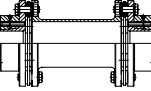
We also supply Kop-Flex® high-performance disc pack couplings (HP and KS ranges) for very demanding applications such as petrochemical, refinery, chemical processing, etc. These couplings are designed and manufactured to meet API 671 & ISO 10441 standards.

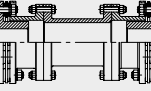
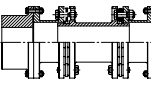
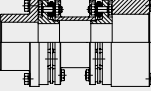
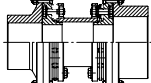

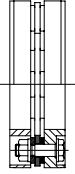
SUMMARY OF CONTENTS

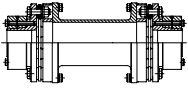
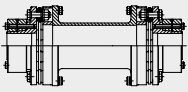
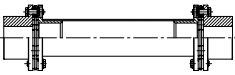
JAURE® LAMIDISC® DISC PACK COUPLING			Page
Description			10
Disc pack kits			11
Coupling Selection			14
Service Factors			15
Balancing			16
Critical Speed			17
Coupling design	Type	Description	Page
	SX-6 / SXR-6	Basic Design, 6 Bolts, according to API 610 on demand	19
	SX-8 / SXR-8	Basic Design, 8 Bolts, according to API 610 on demand	20
	SX-10 / SXR-10	Basic Design, 10 Bolts, according to API 610 on demand	21
	SXFD	With Brake Disc	22
	SX-AC	With Clamping Set	23
	CC	Close Coupled	24
	CC-E	Close Coupled, with Split Spacer	25
	CX	Reduced Moment with Spacer according to AGMA 516	26
	DX	Drop-out with Floating Assembly, Flanges according to AGMA 516	27
	DO-6	Drop-Out, 6 bolts, according to API 610 on demand	28
	DO-8	Drop-Out, 8 bolts, according to API 610 on demand	29

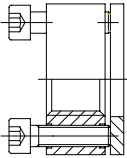
Coupling design	Type	Description	Page
	DOM-6	Drop-Out Modular C, 6 Bolts, according to API 610 on demand	30
	DOM-8	Drop-Out Modular, 8 Bolts, according to API 610 on demand	31
	DOI-AC-6	Drop-Out Inverted, 6 Bolts, with Clamping Set, according to API 610 on demand	32
	DOI-AC-8	Drop-Out Inverted, 8 Bolts, with Clamping Set according to API 610 on demand	33
	JCFS / JGFS	Lamidisc® Coupling with Composite Shaft	34
	AC	Jaure® Clamping Set	36
	JS Nut	Jaure® Super Nut	37
OTHER INFORMATION			Page
Shaft Connection Types			39
Shaft / Bore Fits			40
Lamidisc® Coupling Designs			41
Data Required for Coupling Selection			42
Lamidisc® Coupling References			43

LAMIDISC® DISC PACK COUPLING DESCRIPTION

Jaure® LAMIDISC disc pack couplings

The LAMIDISC disc pack coupling is a backlash-free, torsionally rigid and maintenance-free coupling. Discs are made of high-grade stainless steel, which ensures a high strength, high endurance to fatigue and resistance to most environmental conditions.

LAMIDISC couplings are offered in various designs:

SX Type:

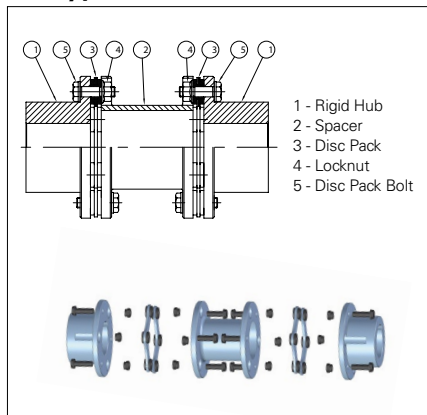

DO Type:

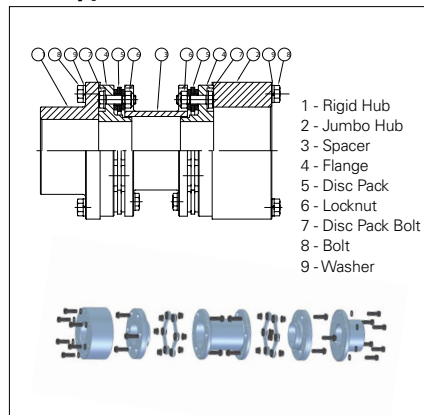

SU Type:

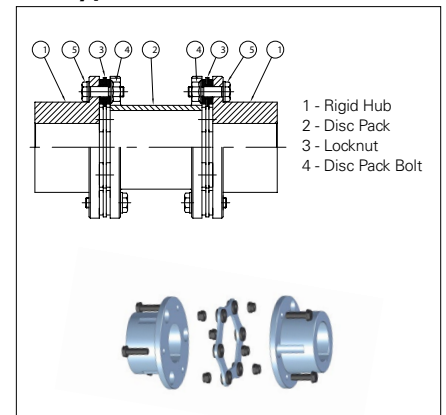

Fig. n.º 1.

LAMIDISC couplings can accommodate three types of misalignment: axial, radial and angular. Please note the SU model does not absorb radial misalignment.

When a Lamidisc coupling is selected with a service factor greater than two ($SF > 2$), it can operate with 100% of its total combined misalignment capacity. With a $SF \leq 2$, it can operate with just 80% of its Total Combined Misalignment capacity.

I.e., as shown on **Permissible Combined Misalignment chart**, a Lamidisc coupling selected with a $SF \leq 2$ can take simultaneously 20% of its axial misalignment capacity plus 60% of its angular misalignment capacity. Therefore, a Lamidisc SX-0202-6 selected with $SF \leq 2$, could operate within $\pm 0,76\text{mm}$ Axial misalignment plus 0,6 degrees angular misalignment.

The angular misalignment is the sum of pure angular misalignment plus the angular misalignment derived from offset.

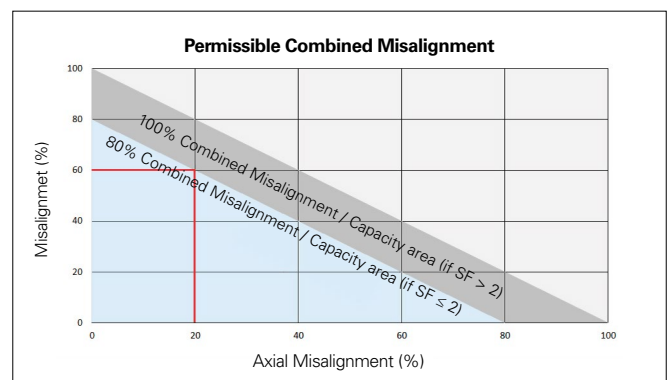
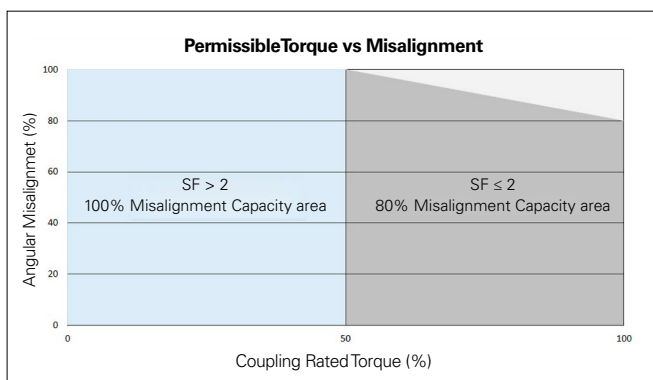

Fig. n.º 2.

Shaft misalignment is a significant cause of machinery failure. An optimal alignment of shaft increases the life of shafting and reduces energy consumption, noise, vibrations and excessive wear.

We perform shaft alignment calculation (DNV GL^{®*} Nauticus^{®*} Machinery Shaft Alignment software), which helps to calculate the bearing reaction loads, moment and stresses for the entire shaft line, as well as to determine the resonance frequencies for whirling and axial vibrations.

JAURE[®] LAMIDISC[®] DISC PACK KITS

Finite element analysis (FEA) led to the optimum disc pack profile in terms of torque transmission and misalignment absorption.

The disc pack kit is composed of a number of individual thin discs which are held together by a socket and a ring to form a compact disc pack. Three different types of JAURE disc packs are available: 6, 8 and 10 bolts. Higher number of bolts means larger torque transmission and lower misalignment absorption capacity.

For the proper operation and optimal lifetime of a Lamidisc coupling, it is of high importance to follow strictly our installation and maintenance manual.

6 Bolts disc pack

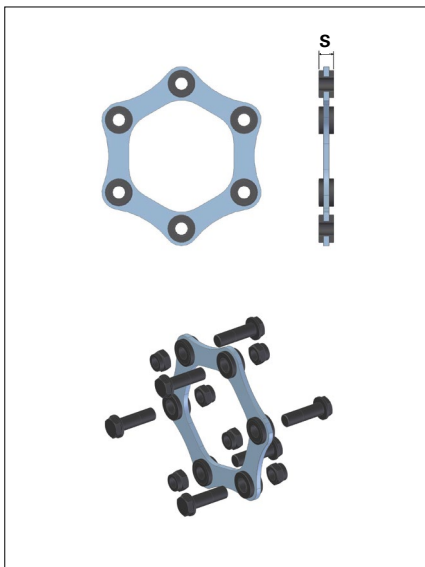

COUPLING SIZE	KIT ARTICLE CODE (1)	TN NOMINAL	TP MAX	S	AXIAL MISALIGNMENT $\pm\Delta K_a$ (2)	ANGULAR MISALIGNMENT $\pm\Delta K_w$ (2)
		Nm	Nm	mm	mm	deg
90-6	KTLA0010021	240	480	7,5	1,5	1
110-6	KTLA0010022	575	1150	8,4	2,1	
132-6	KTLA0010023	1100	2200	8,4	2,6	
158-6	KTLA0010024	2000	4000	11,2	3,1	
185-6	KTLA0010025	3300	6600	14	3,7	
202-6	KTLA0010026	4600	9200	15,5	3,8	
228-6	KTLA0010027	7000	14000	17,5	4,2	
255-6	KTLA0010028	10200	20400	20,5	4,7	
278-6	KTLA0010029	14200	28400	21,2	5,2	
302-6	KTLA0010030	20000	40000	24,4	5,7	
325-6	KTLA0010031	25000	50000	26	6,5	
345-6	KTLA0010054	31000	62000	28,2	6,9	
380-6	KTLA0010060	42300	84600	32	7,6	
410-6	KTLA0010056	57100	114200	33,2	8,2	
440-6	KTLA0010055	73500	147000	36,4	8,8	
475-6	KTLA0010061	92000	184000	38,2	9,5	
505-6	KTLA0010064	117000	234000	42	10,1	
540-6	KTLA0010089	145000	290000	46	10,5	
570-6	KTLA0010090	175000	350000	51,6	11,1	
605-6	KTLA0010091	210000	420000	53,2	11,7	
635-6	KTLA0010092	248000	496000	60,8	12,3	
675-6	KTLA0010093	306000	612000	65,2	13	
700-6	KTLA0010094	349000	698000	68,8	13,5	
730-6	KTLA0010095	413000	826000	71,2	14,2	
760-6	KTLA0010096	473000	946000	72,8	14,8	

**DNV GL and Nauticus are believed to be the trademarks and/or trade names of Det Norske Veritas Group, and are not owned or controlled by Regal Rexnord Corporation.*

8 Bolts disc pack

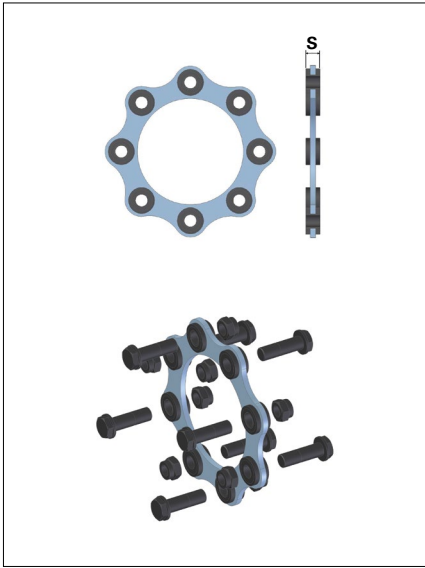

COUPLING SIZE	KIT ARTICLE CODE (1)	TN NOMINAL	TP MAX	S	AXIAL MISALIGNMENT $\pm\Delta K_a$ (2)	ANGULAR MISALIGNMENT $\pm\Delta K_w$ (2)
		Nm	Nm	mm	mm	deg
278-8	KTLA0010032	20000	40000	21,2	3,7	0,5
302-8	KTLA0010033	30000	60000	24,4	4	
325-8	KTLA0010034	37000	74000	26	4,3	
345-8	KTLA0010097	46000	92000	28,2	4,6	
380-8	KTLA0010058	63000	126000	32	5	
410-8	KTLA0010069	86000	172000	33,2	5,4	
440-8	KTLA0010059	110000	220000	36,4	5,8	
475-8	KTLA0010063	138000	276000	38,2	6,3	
505-8	KTLA0010057	175000	350000	42	6,7	
540-8	KTLA0010070	220000	440000	46	7,2	
570-8	KTLA0010071	259000	518000	51,6	7,6	
605-8	KTLA0010013	315000	630000	53,2	7,8	
635-8	KTLA0010098	383000	766000	60,8	8,2	
675-8	KTLA0010099	454000	908000	65,2	8,4	
700-8	KTLA0010100	528000	1056000	68,8	8,9	
730-8	KTLA0010101	608000	1216000	71,2	9,2	
760-8	KTLA0010102	700000	1400000	72,8	9,6	
810-8	KTLA0010103	885000	1770000	76,8	10,7	
875-8	KTLA0010104	1161000	2322000	85,6	11,6	
935-8	KTLA0010105	1460000	2920000	89,6	12,4	
1000-8	KTLA0010106	1836000	3672000	94,4	13,2	
1060-8	KTLA0010107	2271000	4542000	99,2	14	

10 Bolts disc pack

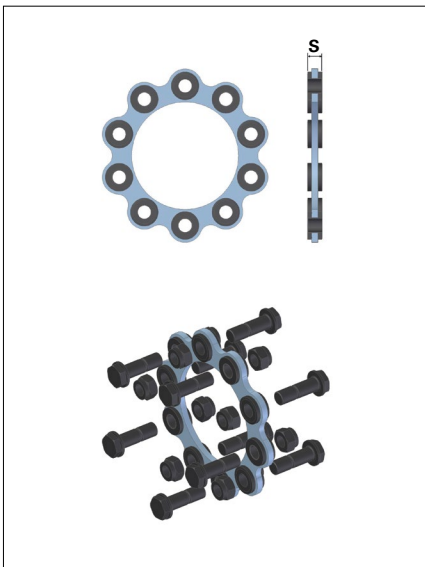

COUPLING SIZE	KIT ARTICLE CODE (1)	TN NOMINAL	TP MAX	S	AXIAL MISALIGNMENT $\pm\Delta K_a$ (2)	ANGULAR MISALIGNMENT $\pm\Delta K_w$ (2)
		Nm	Nm	mm	mm	deg
505-10	KTLA0010108	219000	438000	42	5	0,4
540-10	KTLA0010109	274000	548000	46	5,4	
570-10	KTLA0010110	323000	646000	51,6	5,7	
605-10	KTLA0010111	394000	788000	53,2	5,8	
635-10	KTLA0010112	480000	960000	60,8	6,2	
675-10	KTLA0010113	570000	1140000	65,2	6,4	
700-10	KTLA0010114	660000	1320000	68,8	6,7	
730-10	KTLA0010115	760000	1520000	71,2	7	
760-10	KTLA0010116	870000	1740000	72,8	7,5	
810-10	KTLA0010117	1139000	2278000	76,8	8	
875-10	KTLA0010118	1493000	2986000	85,6	8,7	
935-10	KTLA0010119	1879000	3758000	89,6	9,3	
1000-10	KTLA0010120	2363000	4726000	94,4	9,9	
1060-10	KTLA0010121	2922000	5844000	99,2	10,5	
1120-10	KTLA0010122	3560000	7120000	110	11,1	
1185-10	KTLA0010123	4337000	8674000	115,6	11,8	
1245-10	KTLA0010124	5158000	10316000	120,4	12,4	
1320-10	KTLA0010125	6322000	12644000	126,8	13,1	

► Disc pack kits with overload bushing (R) are also available on demand.

► Spare disc pack kits are available on stock for immediate delivery.



SXR Type



DOR Type

(1) Kit article number includes disc pack with corresponding bolts and locknuts. Each kit corresponds to one (1x) disc pack. In case spare packs for a SX or DO type are required, two (2x) disc pack kits need to be ordered.

(2) Axial misalignment is given for two (2x) disc packs. Angular misalignment is given for one (1x) disc pack. For combined misalignment please refer to Fig. 2 at page 10.

For certain applications, discs packs can be covered on demand with low friction coefficient coating. This will improve their resistance to fretting wear.

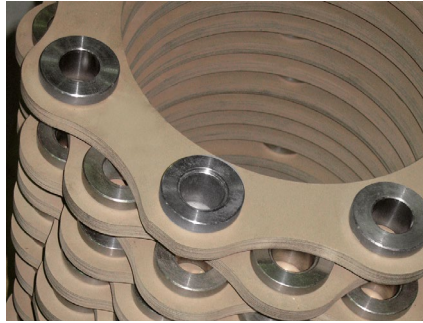

Engineered-to-order solutions

Backed by extraordinary technological capabilities and resources, we can deliver customized, competitively priced couplings and solutions that meet the unique needs of each of our customers with no limit in size.



Lamidisc® coupling 505-8 with JCFS-FP Composite Shafts



Lamidisc® coupling SXVAC-805-6



Lamidisc® coupling 1300-6 in combination with JHC-HF-320

COUPLING SELECTION

For Lamidisc® coupling selection, following application data is required:

- PN, installed or absorbed power (kW)
- n, operating speed (rpm)
- L and d shaft lengths and diameters (mm)
- DBSE distance between shaft ends (mm)
- Service requirements (K service factor from page 15, which is the combined service factor of SFA plus SFD)
- Dynamic misalignment (See combined torque and misalignment on Page 10)
- Additional geometrical or atmospheric restrictions.

Selection procedure

1 / Calculate nominal torque TN (Nm) as follows:

$$T = 9550 \frac{P_N \cdot K}{n}$$

2 / Select Service Factors (K):
Recommended service factors are given on page 15. The service factor can vary for each application and depend on factors including, among others:

- Type of driving and driven machine
- Reversing / Non-reversing load
- Peak torques

Select coupling size from catalogue with nominal torque capacity same or higher than obtained. Check if the peak torque of the application is below the coupling max. torque (TPmax).

3 / Check in catalogue for the maximum bore capacity for selected coupling. Should shafts be larger than the maximum admissible bore, select next bigger coupling size.

4 / Check that the shaft/hub connection can transmit the torque. If necessary, extend the hub length.

5 / Speed given in catalog is the maximum value for balanced

couplings. For higher operational speed, please contact Jaure® coupling engineering for support.

6 / Check dynamic misalignment.

Example:

Select a coupling to connect an electric motor with the gearbox of a harbour crane.

Motor power Pn= 400 kW

Motor speed n= 1500 rpm

Peak torque Tp= 5100 Nm

Motor shaft d1= 70mm

Gearbox input shaft d2= 80mm

Dynamic misalignment < 0,5 degrees

Service Factor for Heavy Duty Hoists with E-motor prime mover in page 15,

K= SFA+SFD= (3+0) = 3

Solution:

Nominal torque needs to be checked as the first step.

$$T = 9550 \times 400 \times 3 / 1500 = 7640 \text{ Nm}$$

From Lamidisc® coupling basic design, we'd select SX-255-6. Secondly, check maximum shaft capacity for selected size (117mm in this case). Finally, check that peak torque of application 5100 Nm is below coupling maximum torque capacity (20400Nm in this case).

RECOMMENDED SERVICE FACTORS (K)

Values listed are intended only as a general guide, and are typical of usual service requirements. For systems which frequently utilize the peak torque capability of the power source, verify that the magnitude of this peak torque does not exceed the 1.0 service factor rating of the coupling selected. Applications which involve quick axial excitations, extreme repetitive shock or high-energy load absorption characteristics should be referred -with full particulars- to Jaure® coupling engineering.

CAUTION: All people moving applications must be referred to Jaure® coupling engineering.

Driven machine service factor SFA Table 1

DRIVEN EQUIPMENT	SFA
ATEX	2
BLOWERS , FAN	
Centrifugal	1.0
Lobe /Vane /Turboblowers	1.25
Forced draught fans	1.5
Induc.draught with damper	1.5
Induc.draught without control	2.0
Cooling towers	2.0
CHEMICAL INDUSTRY	
Agitators (thin liquid)	1.0
Agitators (viscous liquid)	1.5
Centrifuges (light)	1.25
Centrifuges (heavy)	1.75
Mixers	1.75
COMPRESSORS	
Centrifugal	1.0
Lobe / Rotary	1.25
Turbocompressors	1.75
Reciprocating: · 1 to 3 cylinders · 4 or more cylinders	3.0 1.75
CONVEYOR, HOISTS , ELEVATORS. Note 1*	
Conveyors :	
Screw / Apron / Belt / Chain	1.25
Bucket / Rotary / Lifts	1.5
Reciprocating	3.0
Hoists:	
Medium duty	2.5
Heavy duty	3.0
Elevators :	
Centrifugal and gravity disch	1.25
DREDGERS	2.0
FOOD INDUSTRY	
Packaging machines and fillers	1.25
Kneading machines	1.5
Cane crushers	1.5
Cane cutters	1.5
Cane mills	2.0
Sugar beet cutters	1.5
Sugar beet washing machines	1.5
GENERATORS	
Even load	1.0
Frequency converters	1.5
Welding generators	2.0
MACHINE TOOLS	
Main Drives	2.0
Auxiliary and transverse drives	1.5

DRIVEN EQUIPMENT	SFA
MARINE PROPULSION	
	2,25-2,5
METAL WORKING	
Presses / Hammers	2.0
Straighteners	2.0
Bending machines / Shears	1.5
Punching machines	2.0
MINING AND STONES	
Crushers	2.5
Mills	2.5
Mine ventilators	2.0
Vibrators	1.5
OIL INDUSTRY	
Pipeline pumps	1.5
Rotary drilling equipment	2.0
PAPER INDUSTRY	
Calenders	2.0
Couches	2.0
Drying cylinders	2.25
Pulpers	2.0
Pulp grinders	2.0
Suction rolls	2.0
Wet presses	2.0
Reels	2.0
Agitators	2.0
PLASTIC INDUSTRY	
Calenders , Crushers , Mixers	1.75
PUMPS	
Centrifugal, General Feed or Boiler Feed	1.0
Centrifugal, Slurry	1.5
Centrifugal, Dredge	2.0
Rotary / Gear / Lobe or Vane	1.5
Reciprocating:	
1 cylinder	3.0
2 cylinder , single acting	2.0
2 cylinders , double acting	1.75
3 cylinders or more	1.5
ROLLING MILLS	
Billet shears	2.5
Chain transfers	1.5
Cold rolling mills	2.0
Continuous casting plants	2.5
Cooling beds	1.5
Cropping shears	2.0
Cross transfers	1.5
Descaling machines	2.0
Heavy and medium duty mills	3.0
Ingot and blooming mills	2.5

DRIVEN EQUIPMENT	SFA
Ingot handling machinery	2.5
Ingot pushers	2.5
Manipulators	2.0
Plate shears	2.0
Roller adjustment drives	1.5
Roller straighteners	1.5
Roller tables (heavy)	2.5
Roller tables (light)	1.5
Sheet mills	2.5
Trimming shears	1.5
Tube and welding machines	2.0
Winding machines	1.5
Wire drawing benches	1.5
RUBBER INDUSTRY	
Extruder	1.75
Calender	2.0
Mixing mill / Refiner / Crusher	2.5
STEEL PLANTS	
Blast furnace blowers	1.5
Converters	2.5
Inclined blast furnace elev	2.0
Crushers	2.0
TEST BENCHES	2
TEXTILE MACHINES	
Printing and drying machines	1.5
Tanning vats	1.5
Calenders	1.5
Looms	1.5
WATER AND WASTE INDUSTRY	
Aerators, Screw pumps, Screens	1.5
WOOD WORKING MACHINERY	
Trimmers, Barkers, Saws, Planes	2.0

* Note 1: Check local and industrial safety codes.

Driving machine service factor SFD. Table 2

DRIVING EQUIPMENT	SFD
Multi-cylinder engine · 8 or more · 6 · 4 or 5 · Less than 4	0.5 1.0 1.5 Refer to Jaure
Variable speed motors	0.8
Electric motors 1 and turbines	0

BALANCING

Balancing requirements and limits for couplings are mainly dependent upon the characteristics of the application. For this reason, balancing charts should be used only as a guide to assist in determining whether balancing is required or not.

Balancing chart is shown for general applications. For sensitive or critical application, contact Jaure® coupling engineering for coupling balance requirement.

Balance Chart for spacer couplings up to 1500mm of DBSE

(DBSE: Distance between shafts ends. For higher DBSE please refer to Jaure® coupling engineering)

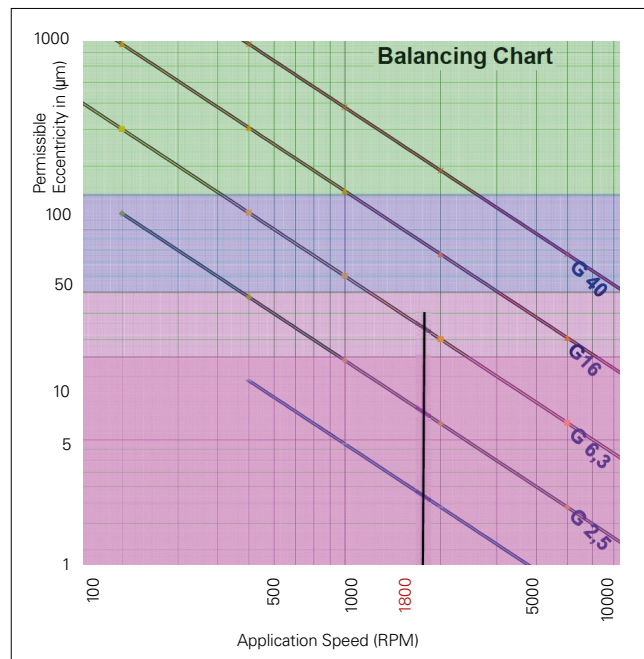

Fig. n.º 3.

- As Manufactured / Component balance spacer
- Component Balancing to G 6.3
- Component Balancing to G 2.5
- Assembly balance

Minimum application data required for chart interpretation:

1. ISO balance grade for the coupling (G)
2. Application speed (n)

This information allows to calculate the permissible eccentricity (e permissible) for the coupling.

$$e_{\text{permissible}} = 9550.G/n$$

Where,

$e_{\text{permissible}}$ = Permissible eccentricity of center of gravity in µm.

e_{coupling} = Actual eccentricity of center of gravity of coupling in µm.

G = Balance Grade in mm/s

n = Application speed in rpm.

In order to satisfy the application requirement, $e_{\text{coupling}} \leq e_{\text{permissible}}$.

Balancing Practices

Jaure® couplings are dynamically balanced in component level or in assembly. In case of assembly balancing level, major components are match-marked to ensure the proper reassembly of the coupling.

Hubs are component balanced at finished bore without keyways unless mentioned in the order.

Balancing reports will be available for customer under request.

Example:

*Coupling Type – Lamidisc® SX coupling.
DBSE – 600 mm
Required Balance Quality – 6.3
Application Speed – 1800 rpm*

As per the chart, we require performance of component balancing to G 2,5 to achieve the 6.3 coupling balance grade as per ISO-1940-1.

*Alternatively:
 $e_{\text{permissible}} = 9550 \cdot G/n$
 $= 9550 \cdot (6.3)/1800$
 $= 33,4 \mu\text{m}$*

From the chart (Y-axis) for 33,4 μm permissible eccentricity, coupling requires component balancing to G 2,5.

CRITICAL SPEED

Critical speed needs to be checked for long intermediate spacer couplings.

Note: For an approximate calculation, the DBSE can be used instead of the distance between flexible elements.

Critical speed for spacer couplings type SX.

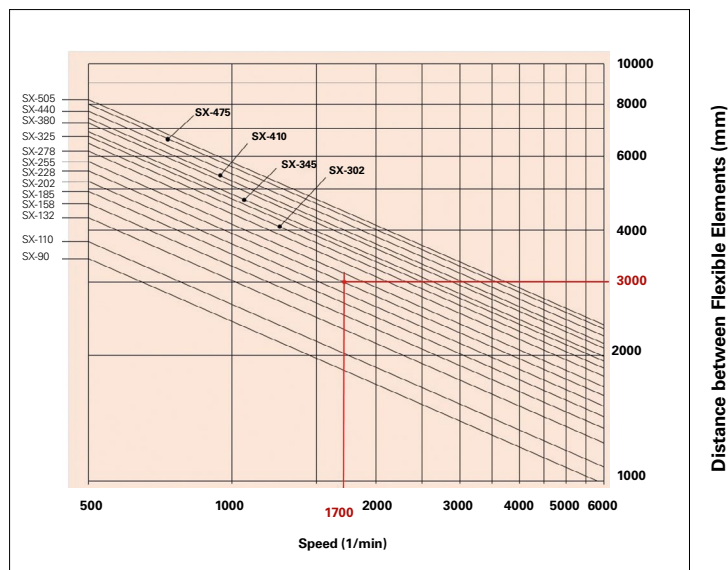

Fig. n.º 4.

Speed (1/min)

Ex.: SX-228 with a spacer of 3000 mm can rotate at a speed maximum 1700 rpm.

LAMIDISC® COUPLINGS DESIGNS.

We supply a wide range of Lamidisc couplings, on their own or in combination with other components, for a great variety of applications:

- **Pulp & Paper:** as retrofit of gear couplings in the two main areas of the paper machine.
- **Cranes & Hoisting:** between main engine and gear box input shaft, with brake disc or drum.
- **Minerals & Mining:** in combination with Max-C® elastic couplings.
- **Petrochemical / Oil & Gas:** with electrical insulation.
- **Cooling Towers:** in combination with JGFS glass fiber and JCFS carbon fiber spacers.
- **Wind turbines:** in combination with composite tubes, with special coatings, etc.
- **Marine:**
 - *Propulsion drives:* in combination with composite shafts, bulkhead seals, split type bearings, etc.
 - *High speed vessels:* between gearbox and waterjet drive: in combination with steel and composite shafts, bulkhead seals, split type bearings, brake and locking devices, etc.
 - *Thrusters:* Tunnel, Azimuth, Retractable, etc.

MARINE TYPE APPROVAL & MANUFACTURING SURVEY ARRANGEMENT

The Jaure LAMIDISC® couplings can be also delivered on demand with the 3.2 certificate of any Marine Classification Society.

We have also been awarded the Manufacturing Survey Arrangement – MSA from DNV. The MSA certificate shows our commitment to continuously improve the service and response time to our customers and remain competitive in the industry.



SX-6, SXR-6: BASIC DESIGN, 6 BOLTS, ACCORDING TO API 610 ON DEMAND

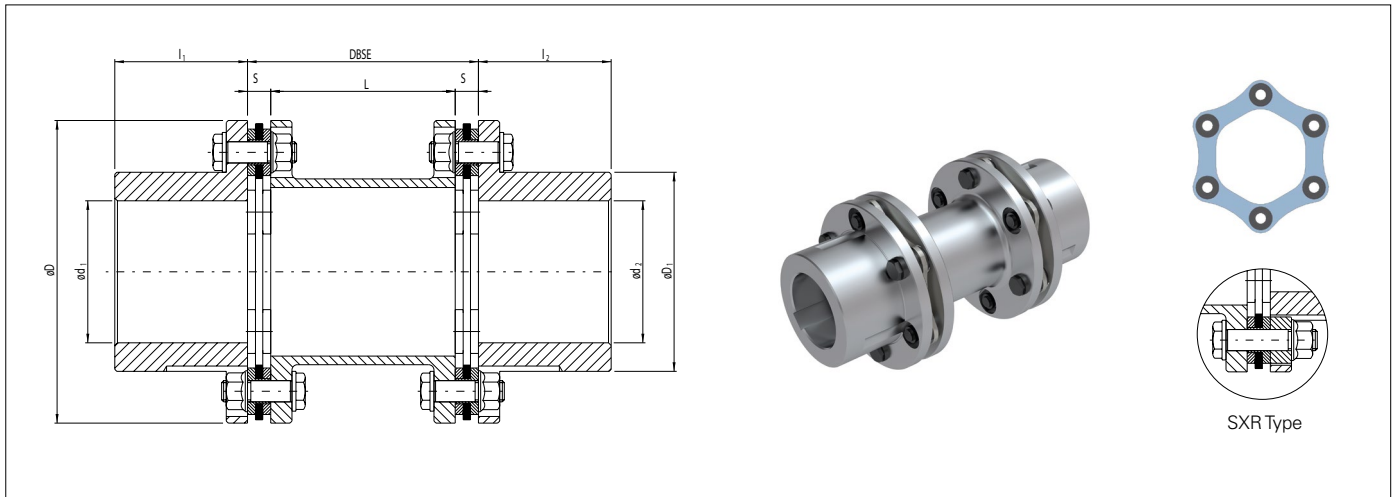

Designation example: **SX-110-6, DBSE = 140mm**

SIZE	TN NOMINAL (1)	TP MAX (1)	n MAX (2)	GENERAL DIMENSIONS (mm)							WEIGHT (5)	MASSMOMENT OF INERTIA (5)
				D	D1	d1-d2 max. (3)	l1-l2	DBSE min (4)	L	S		
SX-6	Nm	Nm	rpm	D	D1	d1-d2 max. (3)	l1-l2	DBSE min (4)	L	S	kg	J (kgm ²)
90-6	240	480	15920	90	58	41	40	71	56	7,5	2,1	0,002
110-6	575	1150	13020	110	70	50	50	88	71,2	8,4	2,9	0,004
132-6	1100	2200	10850	132	89	65	60	108	91,2	8,4	5,5	0,012
158-6	2000	4000	9070	158	104	75	70	124	101,6	11,2	8,6	0,025
185-6	3300	6600	7740	185	121	87	80	140	112	14	15	0,063
202-6	4600	9200	7090	202	132	95	90	158	127	15,5	21	0,11
228-6	7000	14000	6280	228	150	107	100	174	139	17,5	30	0,20
255-6	10200	20400	5620	255	163	117	115	196	155	20,5	40	0,32
278-6	14200	28400	5150	278	183	131	125	218	175,6	21,2	57	0,56
302-6	20000	40000	4740	302	201	145	135	234	185,2	24,4	74	0,86
325-6	25000	50000	4410	325	219	156	145	254	202	26	89	1,17
345-6	31000	62000	4150	345	230	165	155	270	213,6	28,2	109	1,63
380-6	42300	84600	3770	380	249	178	170	296	232	32	146	2,64
410-6	57100	114200	3490	410	269	192	185	320	253,6	33,2	190	4,04
440-6	73500	147000	3260	440	289	206	195	334	261,2	36,4	224	5,45
475-6	92000	184000	3020	475	309	220	210	358	281,6	38,2	288	8,20
505-6	117000	234000	2840	505	327	233	230	394	310	42	366	12

- Puller holes can be made upon request.
- Set screws can be included upon request.

- Adapted hub length available upon request.
- SXR overload bushings available upon request.

- JS nuts available upon request.
- Certified according to ATEX 94/9 EC (ATEX 95), categories 2G/2D.



(1) The torque of the coupling does not include the connection transmission capacity.

(2) n MAX speed for balanced couplings. For higher speeds contact Jaure® coupling engineering. For long DBSE, please check Figure 4 at page 17.

(3) Max. allowable bore for couplings with DIN 6885/1 keys. For other types of keys or connections please contact Jaure® coupling engineering.

(4) DBSE is distance between shaft ends. Different DBSE to be specified by customer.

(5) Weight and moment of inertia based on maximum bores.

SX-8, SXR-8: BASIC DESIGN, 8 BOLTS, ACCORDING TO API 610 ON DEMAND

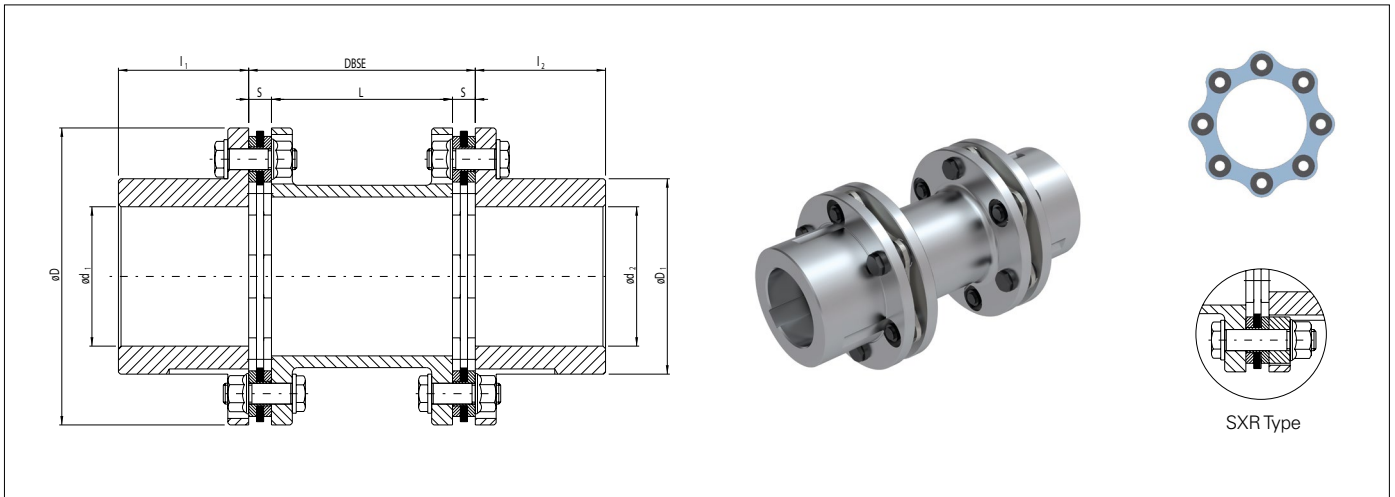

Designation example: **SX-278-8, DBSE = 240mm**

SIZE	TN NOMINAL (1)	TP MAX (1)	n MAX (2)	GENERAL DIMENSIONS (mm)							WEIGHT (5)	MASSMOMENT OF INERTIA (5)
				D	D1	d1-d2 max. (3)	l1-l2	DBSE min (4)	L	S		
SX-8	Nm	Nm	rpm	D	D1	d1-d2 max. (3)	l1-l2	DBSE min (4)	L	S	kg	kgm ²
278-8	20000	40000	5150	278	183	131	125	218	175,6	21,2	59	0,57
302-8	30000	60000	4740	302	201	145	135	234	185,2	24,4	77	0,88
325-8	37000	74000	4410	325	219	156	145	254	202	26	92	1,2
345-8	46000	92000	4150	345	230	165	155	270	213,6	28,2	112	1,66
380-8	63000	126000	3770	380	249	178	170	296	232	32	150	2,71
410-8	86000	172000	3490	410	269	192	185	320	253,6	33,2	195	4,11
440-8	110000	220000	3260	440	289	206	195	334	261,2	36,4	230	5,54
475-8	138000	276000	3020	475	309	220	210	358	281,6	38,2	295	8,32
505-8	175000	350000	2840	505	327	233	230	394	310	42	374	12,1
540-8	220000	440000	2650	540	330	235	240	416	324	46	454	16,8
570-8	259000	518000	2510	570	350	250	250	450	346,8	51,6	535	22
605-8	315000	630000	2370	605	370	265	265	474	367,6	53,2	617	28
635-8	383000	766000	2260	635	385	275	280	521	399,4	60,8	728	36,6
675-8	454000	908000	2120	675	410	290	300	558	427,6	65,2	875	48,6
700-8	528000	1056000	2050	700	420	300	315	595	457,4	68,8	1021	62,3
730-8	608000	1216000	1960	730	440	315	330	610	467,6	71,2	1130	74,9
760-8	700000	1400000	1880	760	460	330	350	642	496,4	72,8	1310	94,9

- Puller holes can be made upon request.
- Set screws can be included upon request.

- Adapted hub length available upon request.
- SXR overload bushings available upon request.

- JS nuts available upon request.
- Certified according to ATEX 94/9 EC (ATEX 95), categories 2G/2D.



(1) The torque of the coupling does not include the connection transmission capacity.

(2) n MAX speed for balanced couplings. For higher speeds contact Jaure® coupling engineering. For long DBSE, please check Figure 4 at page 17.

(3) Max. allowable bore for couplings with DIN 6885/1 keys. For other types of keys or connections please contact Jaure® coupling engineering.

(4) DBSE is distance between shaft ends. Different DBSE to be specified by customer.

(5) Weight and moment of inertia based on maximum bores.

SX-10, SXR-10: BASIC DESIGN, 10 BOLTS, ACCORDING TO API 610 ON DEMAND

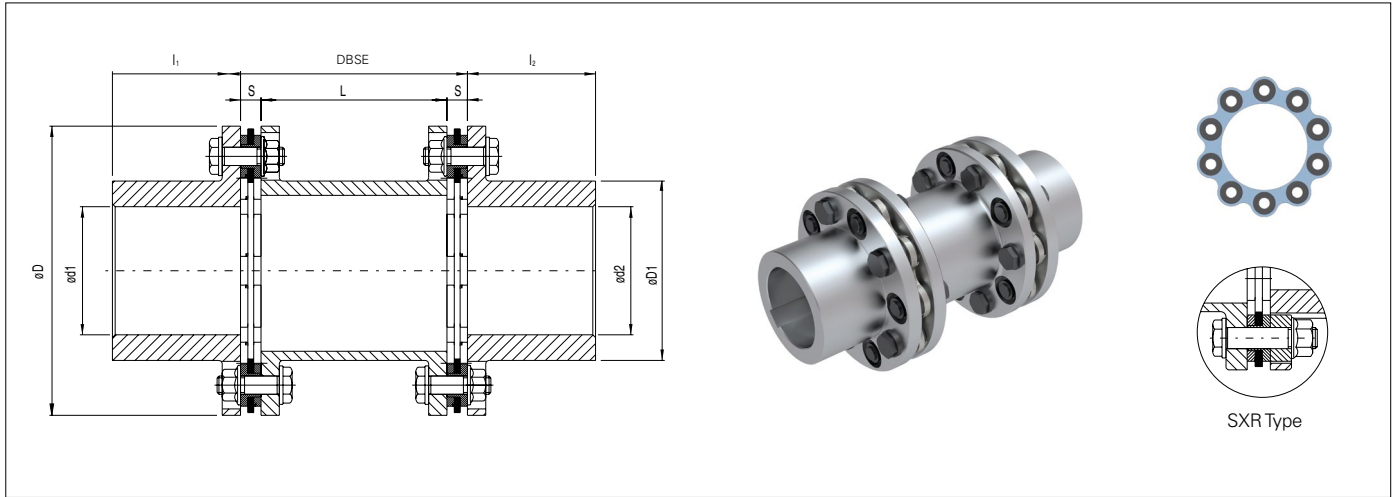

Designation example: **SX-505-10, DBSE = 650mm**

SIZE	TN NOMINAL (1)	TP MAX (1)	n MAX (2)	GENERAL DIMENSIONS (mm)							WEIGHT (5)	MASSMOMENT OF INERTIA (5)
				D	D1	d1-d2 max. (3)	l1-l2	DBSE min (4)	L	S		
SX-10	Nm	Nm	rpm	D	D1	d1-d2 max. (3)	l1-l2	DBSE min (4)	L	S	kg	kgm ²
505-10	219000	438000	2840	505	327	233	230	394	310	42	378	12,2
540-10	274000	548000	2650	540	330	235	240	416	324	46	459	16,9
570-10	323000	646000	2510	570	350	250	250	450	346,8	51,6	540	22,1
605-10	394000	788000	2370	605	370	265	265	474	367,6	53,2	622	28,1
635-10	480000	960000	2260	635	385	275	280	521	399,4	60,8	734	36,8
675-10	570000	1140000	2120	675	410	290	300	558	427,6	65,2	882	48,9
700-10	660000	1320000	2050	700	420	300	315	595	457,4	68,8	1029	62,6
730-10	760000	1520000	1960	730	440	315	330	610	467,6	71,2	1139	75,2
760-10	870000	1740000	1880	760	460	330	350	642	496,4	72,8	1320	95,3

- Puller holes can be made upon request.
- Set screws can be included upon request.

- Adapted hub length available upon request.
- SXR overload bushings available upon request.

- JS nuts available upon request.
- Certified according to ATEX 94/9 EC (ATEX 95), categories 2G/2D



- (1) The torque of the coupling does not include the connection transmission capacity.
 (2) n MAX speed for balanced couplings. For higher speeds contact Jaure® coupling engineering.
 For long DBSE, please check Figure 4 at page 17.

- (3) Max. allowable bore for couplings with DIN 6885/1 keys. For other types of keys or connections please contact Jaure® coupling engineering.

- (4) DBSE is distance between shaft ends. Different DBSE to be specified by customer.
 (5) Weight and moment of inertia based on maximum bores.

SXFD-6: WITH BRAKE DISC

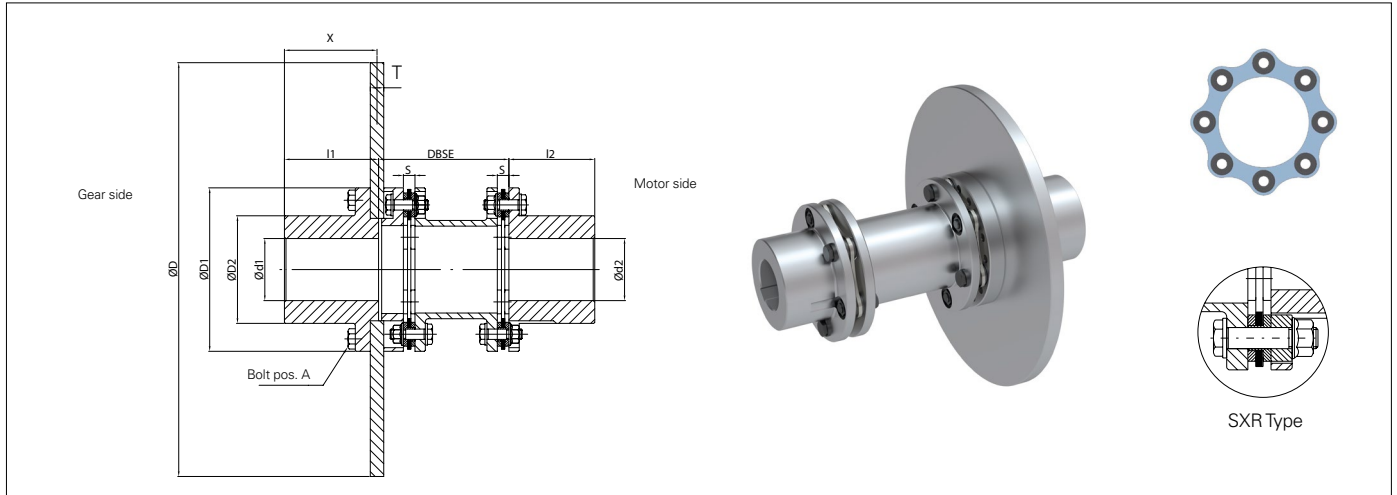

Designation example: **SXFD-132-6, DBSE = 150mm, Disc Ø315x30, Speed (rpm)**

SIZE	TN NOMINAL (1)	TP MAX (1)	n MAX (2)	GENERAL DIMENSIONS (mm)										BOLT DATA pos.A (5)		WEIGHT (6)	MASSMOMENT OF INERTIA (6)
				d1-d2 Max. (3)	D	T	D1	D2	I1	I2	DBSE (4)	S	X	Z-M	Nm		
90-6	240	480	5000	41	215	12.7	90	58	60	40	79,2	7,5	64,35	12-M6	15	6	0,023
110-6	575	1150	5000	50	215 315	12.7 12.7	110	70	70	50	103,7	8,4	74,35	12-M8	35	8,3 12	0,028 0,10
132-6	1100	2200	3500 3100	65	315 355	30 30	132	89	85	60	105	8,4	80	12-M8	35	23 28	0,24 0,38
158-6	2000	4000	3500 3100 2800	75	315 355 395	30 30 30	158	104	110	70	131	11,2	105	12-M10	60	31 36 41	0,27 0,41 0,60
185-6	3300	6600	2800 2500 2200	87	395 445 495	30 30 30	185	121	110	80	148	14	105	12-M12	120	49 57 66	0,65 0,99 1,47
202-6	4600	9200	2500 2200 2000	95	445 495 550	30 30 30	202	132	140	90	170	15,5	135	12-M14	190	65 73 84	1,05 1,53 2,26
228-6	7000	14000	2200 2000 1800	107	495 550 625	30 30 30	228	150	170	100	187	17,5	165	12-M16	295	87 98 114	1,66 2,39 3,80
255-6	10200	20400	1800 1600	117	625 705	30 30	255	163	170	115	241	20,5	165	12-M18	405	130 150	4,01 6,20
278-6	14200	28400	1800 1600 1400	131	625 705 795	30 30 30	278	183	210	125	263	21,2	205	12-M20	580	153 173 198	4,29 6,48 10
302-6	20000	40000	1600 1400	145	705 795	30 30	302	201	210	135	282,3	24,4	205	12-M24	1000	195 220	6,88 10,4
325-6	25000	50000	1600 1400 1100	156	705 795 995	30 30 40	325	219	250	145	302 302 307	26	245 245 240	12-M22	780	219 244 368	7,39 10,9 31,9
345-6	31000	62000	1400 1100	165	795 995	30 40	345	230	250	155	321 326	28,2	245 240	12-M24	1000	268 393	11,4 32,4
380-6	42300	84600	1400 1100	178	795 995	30 40	380	249	290	170	353 358	32	285 280	12-M24	1000	310 434	12,8 33,8
410-6	57100	114200	1400 1100	192	795 995	30 40	410	269	290	185	382 387	33,2	285 280	12-M27	1500	346 469	14,4 35,4
440-6	73500	147000	1100	206	995	40	440	289	340	195	402	36,4	330	12-M27	1500	554	38
475-6	92000	184000	1100	220	995	40	475	309	340	210	430	38,2	330	12-M30	2000	625	41,5
505-6	117000	234000	1100	233	995	40	505	327	400	230	472,5	42	390	12-M30	2000	715	45,7

- Puller holes can be made upon request.
- Set screws can be included upon request.

- Adapted hub length available upon request.
- JS nuts available upon request.

- Certified according to ATEX 94/9 EC (ATEX 95), categories 2G/2D.



- (1) The torque of the coupling does not include the connection transmission capacity.
 (2) Disk speeds St-52.3 material balanced to G 6.3 ISO 1940. For higher speeds consult Jaure® coupling engineering.

- (3) Max. allowable bore for couplings with DIN 6885/1 keys. For other types of keys or connections please contact Jaure® coupling engineering.
 (4) DBSE is distance between shaft ends, not between flanges. Different DBSE to be specified by customer.

- (5) Torque values dry. For lubricated, reduce these values by 20%.
 (6) Weight and moment of inertia based on maximum bores.

SX-AC: WITH CLAMPING SET

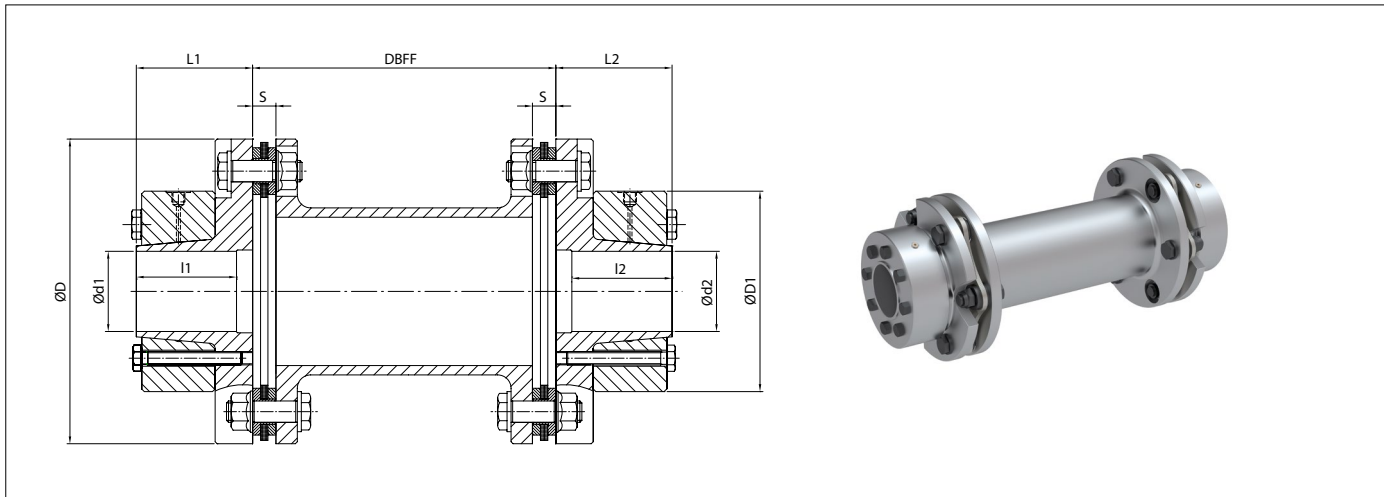

Designation example: **SX - AC - 132 - 6, DBFF= 150mm**

SIZE	TN NOMINAL (1)	TP MAX (1)	n MAX (2)	GENERAL DIMENSIONS (mm)							WEIGHT (5)	MASSMOMENT OF INERTIA (5)
				D	D1	d1-d2 Max. (3)	l1-l2 (6)	L1-L2 (6)	DBFF (4)	S		
SX-AC	Nm	Nm	rpm	D	D1	d1-d2 Max. (3)	l1-l2 (6)	L1-L2 (6)	DBFF (4)	S	kg	J (kgm ²)
90-6	240	480	15920	90	85	20	47	53	71	7,5	4,9	0,005
110-6	575	1150	13020	110	110	25	54	60	88	8,4	9,3	0,014
132-6	1100	2200	10850	132	110	30	54	60	108	8,4	11	0,019
158-6	2000	4000	9070	158	130	40	60	68	124	11,2	17	0,047
185-6	3300	6600	7740	185	140	45	66	76	140	14	24	0,087
202-6	4600	9200	7090	202	140	50	70	79	158	15,5	27	0,11
228-6	7000	14000	6280	228	150	60	75	87	174	17,5	36	0,20
255-6	10200	20400	5620	255	160	70	72	80	196	20,5	48	0,34
278-6	14200	28400	5150	278	180	80	78	85	218	21,2	58	0,50
302-6	20000	40000	4740	302	180	90	92	98	234	24,4	71	0,73
325-6	25000	50000	4410	325	225	100	105	119	254	26	102	1,16
345-6	31000	62000	4150	345	245	110	105	126	270	28,2	125	1,64
380-6	42300	84600	3770	380	254	120	110	136	296	32	156	2,50
410-6	57100	114200	3490	410	280	130	130	156	320	33,2	209	3,88
440-6	73500	147000	3260	440	300	140	135	166	334	36,4	262	5,65
475-6	92000	184000	3020	475	330	150	150	182	358	38,2	342	8,57
505-6	117000	234000	2840	505	355	160	165	199	394	42	426	12

- Adapted hub length available upon request.
- JS nuts available upon request.

- Certified according to ATEX 94/9 EC (ATEX 95), categories 2G/2D.



- (1) The torque of the coupling does not include the connection transmission capacity.
- (2) n MAX speed for balanced couplings. For higher speeds contact Jaure® coupling engineering. For long DBFF, please check Figure 4 at page 17.

- (3) Max. allowable bores for standard design. For bigger bores please contact Jaure® coupling engineering.
- (4) DBFF is distance between flange faces, not between shafts. Different DBFF to be specified by customer.

- (5) Weight and moment of inertia based on maximum bores.
- (6) Available shaft length for connection should be within l1 (min. shaft penetration) to L1 (Max. shaft penetration); and l2 to L2 respectively.

CC: CLOSE COUPLED

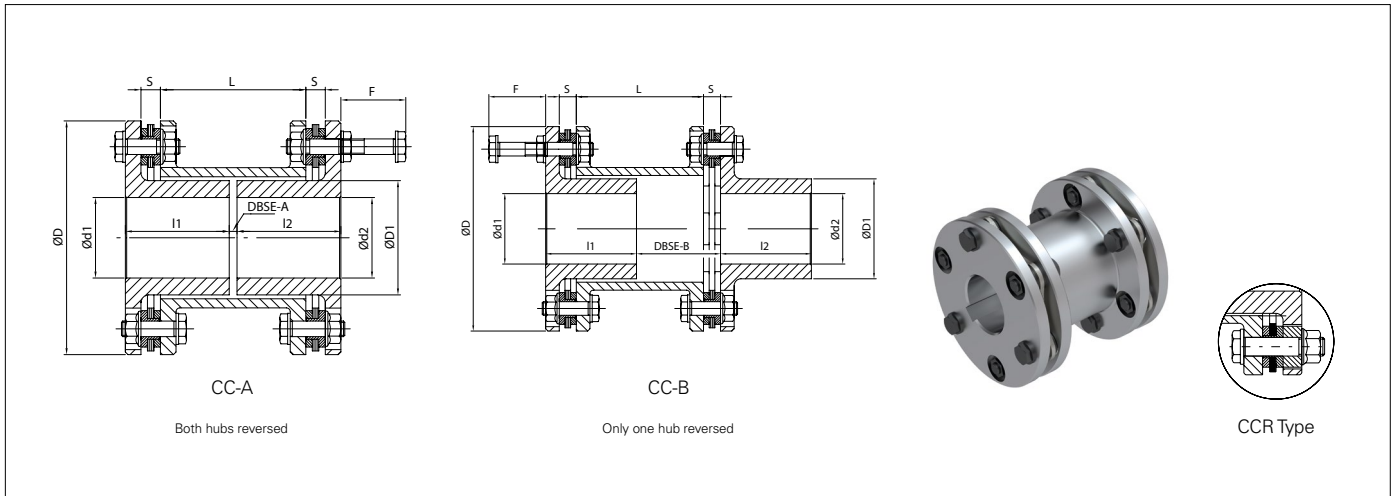

Designation example: **CC-A-158-6, DBSE = 4 mm**

SIZE	TN NOMINAL (1)	TP MAX (1)	n MAX (2)	GENERAL DIMENSIONS (mm)									WEIGHT (5) kg	MASSMOMENT OF INERTIA (5) J (kgm ²)
				D	D1	d1-d2 Max. (3)	I1-I2	DBSE-A (4)	DBSE-B (4)	L	S	F (6)		
90-6	240	480	15920	90	44	31	40	3	37	56	7,5	30	1,7	0,002
110-6	575	1150	13020	110	54	39	50	4	46	71,2	8,4	45	1,8	0,003
132-6	1100	2200	10850	132	71	50	60	4	56	91,2	8,4	45	3,8	0,010
158-6	2000	4000	9070	158	84	60	70	4	64	101,6	11,2	55	5,8	0,021
185-6	3300	6600	7740	185	95	68	80	4	72	112	14	65	10	0,053
202-6	4600	9200	7090	202	108	75	90	6	82	127	15,5	75	15	0,091
228-6	7000	14000	6280	228	123	85	100	6	90	139	17,5	85	21	0,17
255-6	10200	20400	5620	255	135	95	115	6	101	155	20,5	100	27	0,27
278-6	14200	28400	5150	278	152	105	125	8	113	175,6	21,2	105	36	0,46
302-6	20000	40000	4740	302	165	115	135	8	121	185,2	24,4	115	46	0,71
325-6	25000	50000	4410	325	174	125	145	8	131	202	26	115	55	0,96
345-6	31000	62000	4150	345	186	130	155	8	139	213,6	28,2	125	70	1,34
380-6	42300	84600	3770	380	204	145	170	10	153	232	32	140	92	2,17
410-6	57100	114200	3490	410	223	160	185	10	165	253,6	33,2	150	116	3,28
440-6	73500	147000	3260	440	233	165	195	10	172	261,2	36,4	165	136	4,46
475-6	92000	184000	3020	475	252	180	210	10	184	281,6	38,2	180	172	6,71
505-6	117000	234000	2840	505	266	190	230	12	203	310	42	195	228	9,76

- Puller holes can be made upon request.
- Set screws can be included upon request.

- Adapted hub length available upon request.
- CCR overload bushings available upon request.

- JS nuts available upon request.
- Certified according to ATEX 94/9 EC, categories 2G/2D



- (1) The torque of the coupling does not include the connection transmission capacity.
 (2) n MAX speed for balanced couplings. For higher speeds contact Jaure® coupling engineering.

- (3) Max. allowable bore for couplings with DIN 6885/1 keys. For other types of keys or connections please contact Jaure® coupling engineering.

- (4) DBSE is distance between shaft ends. Different DBSE to be specified by customer.
 (5) Weight and moment of inertia based on maximum bores.
 (6) F: Clearance to allow removal of bolts.

CC-E: CLOSE COUPLED WITH SPLIT SPACER

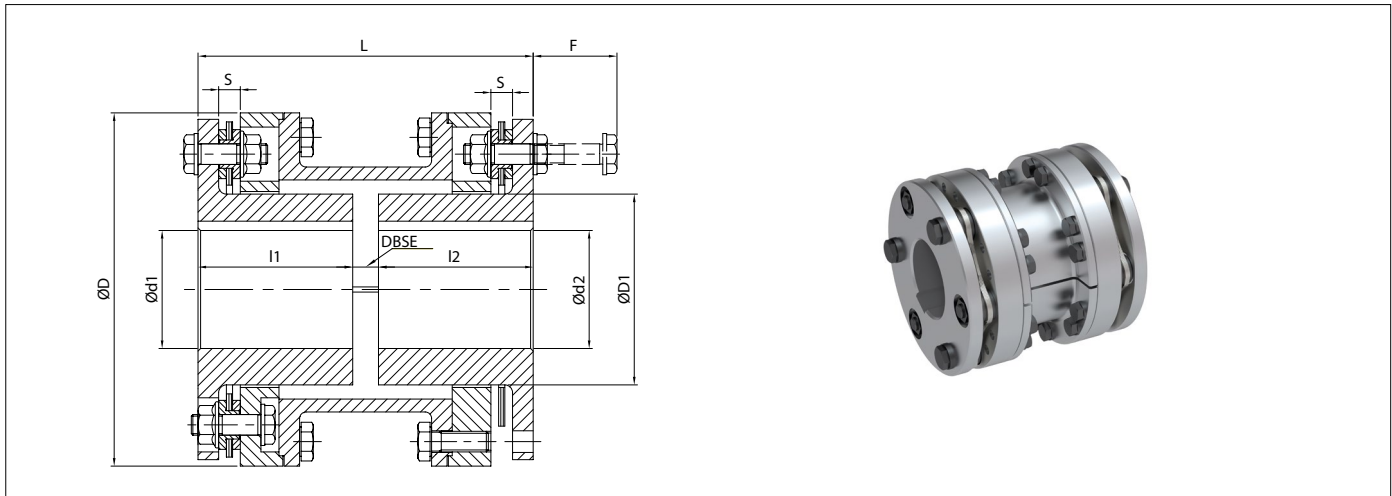

Designation example: **CC-E 110-6, DBSE=11mm.**

SIZE	TN NOMINAL (1)	TP MAX (1)	n MAX (2)	GENERAL DIMENSIONS (mm)									WEIGHT (5)	MASSMOMENT OF INERTIA (5)
				D	D1	d1-d2 Max. (3)	I1-I2	DBSE (4)	L	F (6)	S			
CC-E-6	Nm	Nm	rpm	D	D1	d1-d2 Max. (3)	I1-I2	DBSE (4)	L	F (6)	S	kg	J (kgm ²)	
90-6	240	480	15920	94	47	34	40	9	89	30	7,5	2,6	0,003	
110-6	575	1150	13020	115	59	42	50	10	110	45	8,4	5,2	0,009	
132-6	1100	2200	10850	137	74	53	60	10	130	45	8,4	7,7	0,019	
158-6	2000	4000	9070	158	88	63	70	12	152	55	11,2	13	0,044	
185-6	3300	6600	7740	185	100	71	80	15	175	65	14	20	0,092	
202-6	4600	9200	7090	210	113	81	90	17	197	78	15,5	25	0,15	
228-6	7000	14000	6280	228	127	91	100	19	219	85	17,5	40	0,28	
255-6	10200	20400	5620	255	139	99	115	21	251	100	20,5	58	0,51	
278-6	14200	28400	5150	278	155	111	125	22	272	105	21,2	71	0,74	
302-6	20000	40000	4740	302	170	121	135	26	296	115	24,4	90	1,10	

- Puller holes can be made upon request.
- Set screws can be included upon request.

- Adapted hub length available upon request.
- CCR overload bushings available upon request.

- JS nuts available upon request.
- Certified according to ATEX 94/9 EC, categories 2G/2D.



- (1) The torque of the coupling does not include the connection transmission capacity.
 (2) n MAX speed for balanced couplings. For higher speeds contact Jaure® coupling engineering.

- (3) Max. allowable bore for couplings with DIN 6885/1 keys. For other types of keys or connections please contact Jaure® coupling engineering.

- (4) DBSE is distance between shaft ends. Different DBSE to be specified by customer.
 (5) Weight and moment of inertia based on maximum bores.
 (6) F: Clearance to allow removal of bolts.

CX: REDUCED MOMENT WITH SPACER ACCORDING TO AGMA 516

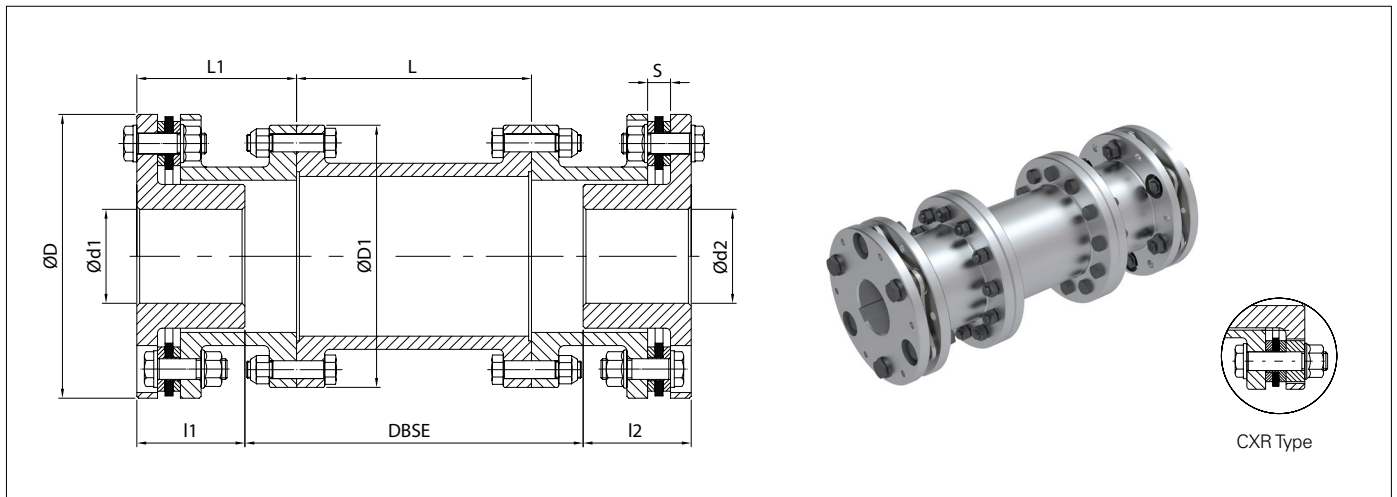

Designation example: **CX-132-6/10, DBSE = 200 mm**

SIZE	TN NOMINAL (1)	TP MAX (1)	n MAX (2)	GENERAL DIMENSIONS (mm)								WEIGHT (5)	MASSMOMENT OF INERTIA (5)
				D	D1	d1-d2 max. (3)	I1-I2	DBSE (4)	L	L1	S		
CX	Nm	Nm	rpm	D	D1	d1-d2 max. (3)	I1-I2	DBSE (4)	L	L1	S	kg	J (kgm ²)
132-6/10	1100	2200	10850	132	116	50	60	97	85	66	8,4	7,8	0,017
158-6/15	2000	4000	9070	158	152	60	70	132	110	81	11,2	16	0,056
185-6/20	3300	6600	7740	185	178	70	80	147	115	96	14	24	0,11
202-6/25	4600	9200	7090	202	213	75	90	175	135	110	15,5	38	0,23
255-6/30	10200	20400	5620	255	240	95	115	165	135	130	20,5	57	0,49
278-8/35	20000	40000	5150	278	279	100	125	225	175	150	21,2	91	1,02
302-8/40	30000	60000	4740	302	318	110	135	225	175	160	24,4	118	1,64
325-8/45	37000	74000	4410	325	346	115	145	215	175	165	26	134	2,23
345-8/50	46000	92000	4150	345	389	125	155	280	220	185	28,2	196	4
380-8/55	63000	126000	3770	380	425	140	170	280	220	200	32	245	5,92
410-8/60	86000	172000	3490	410	457	150	185	210	180	200	33,2	254	6,87
540-8/70	220000	440000	2650	540	527	195	240	190	200	235	46	508	21,1

- Puller holes can be made upon request.
- Set screws can be included upon request.

- Adapted hub length available upon request.
- CXR overload bushings available upon request.

- JS nuts available upon request.
- Certified according to ATEX 94/9 EC (ATEX 95), categories 2G/2D.



(1) The torque of the coupling does not include the connection transmission capacity.

(2) n MAX speed for balanced couplings. For higher speeds contact Jaure® coupling engineering. For long DBSE, please check Figure 4 at page 17.

(3) Max. allowable bore for couplings with DIN 6885/1 keys. For other types of keys or connections please contact Jaure® coupling engineering.

(4) DBSE is distance between shaft ends. Different DBSE to be specified by customer.

(5) Weight and Moment of inertia based on maximum bores.

DX: DROP OUT WITH FLOATING ASSEMBLY, FLANGES ACCORDING TO AGMA 516

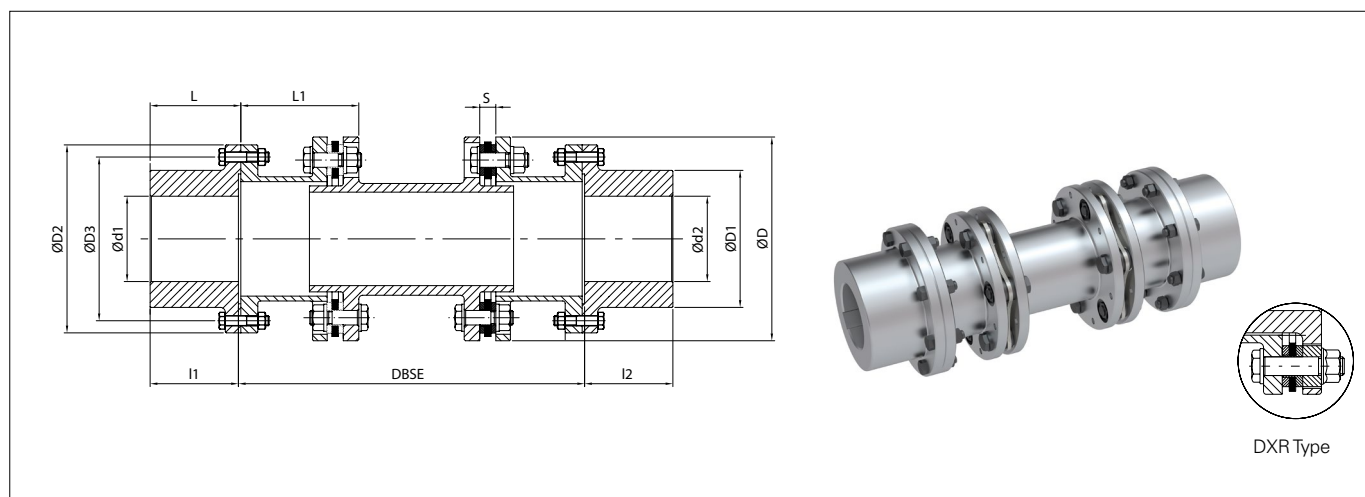

Designation example: **DX-132-6/10, DBSE=200mm.**

SIZE	TN NOMINAL (1)	TP MAX (1)	n MAX (2)	GENERAL DIMENSIONS (mm)										WEIGHT (5)	MASSMOMENT OF INERTIA (5)
				D	D1	D2	D3	d1-d2 Max. (3)	I1-I2	DBSE (4)	L	L1	S		
DX	Nm	Nm	rpm	D	D1	D2	D3	d1-d2 Max. (3)	I1-I2	DBSE (4)	L	L1	S	kg	J (kgm ²)
132-6/10	1100	2200	10850	132	80	116	95,2	55	40	170	42	66	8,4	5	0,013
158-6/15	2000	4000	9070	158	100	152	122,2	70	47	225	49,5	81	11,2	11	0,039
185-6/20	3300	6600	7740	185	125	178	149,2	90	58	265	60,5	96	14	17	0,084
202-6/25	4600	9200	7090	202	148	213	180,9	105	74	300	76,5	110	15,5	24	0,15
255-6/30	10200	20400	5620	252	173	240	206,4	120	88	365	90,5	130	20,5	42	0,40
278-8/35	20000	40000	5150	278	204	279	241,3	145	102	405	105	150	21,2	67	0,75
302-8/40	30000	60000	4740	302	242	318	279,4	170	113	440	118	160	24,4	86	1,18
325-8/45	37000	74000	4410	325	268	346	304,8	190	129	455	134	165	26	102	1,62
345-8/50	46000	92000	4150	345	302	389	342,9	215	144	500	149	185	28,2	139	2,67
380-8/55	63000	126000	3770	380	327	425	368,3	230	175	545	181	200	32	179	4,10
410-8/60	86000	172000	3490	410	354	457	400	250	188	555	194	200	33,2	199	5,15
540-8/70	220000	440000	2650	540	410	527	463,5	290	221	680	227	235	46	419	17,6

- Puller holes can be made upon request.
- Set screws can be included upon request.

- Adapted hub length available upon request.
- DXR overload bushings available upon request.

- JS nuts available upon request.
- Certified according to ATEX 94/9 EC (ATEX 95), categories 2G/2D.



(1) The torque of the coupling does not include the connection transmission capacity.

(2) n MAX speed for balanced couplings. For higher speeds contact Jaure® coupling engineering. For long DBSE, please check Figure 4 at page 17.

(3) Max. allowable bore for couplings with DIN 6885/1 keys. For other types of keys or connections please contact Jaure® coupling engineering.

(4) DBSE is distance between shaft ends. Different DBSE to be specified by customer.

(5) Weight and moment of inertia based on maximum bores.

DO-6: DROP-OUT, 6 BOLTS, ACCORDING TO API 610 ON DEMAND

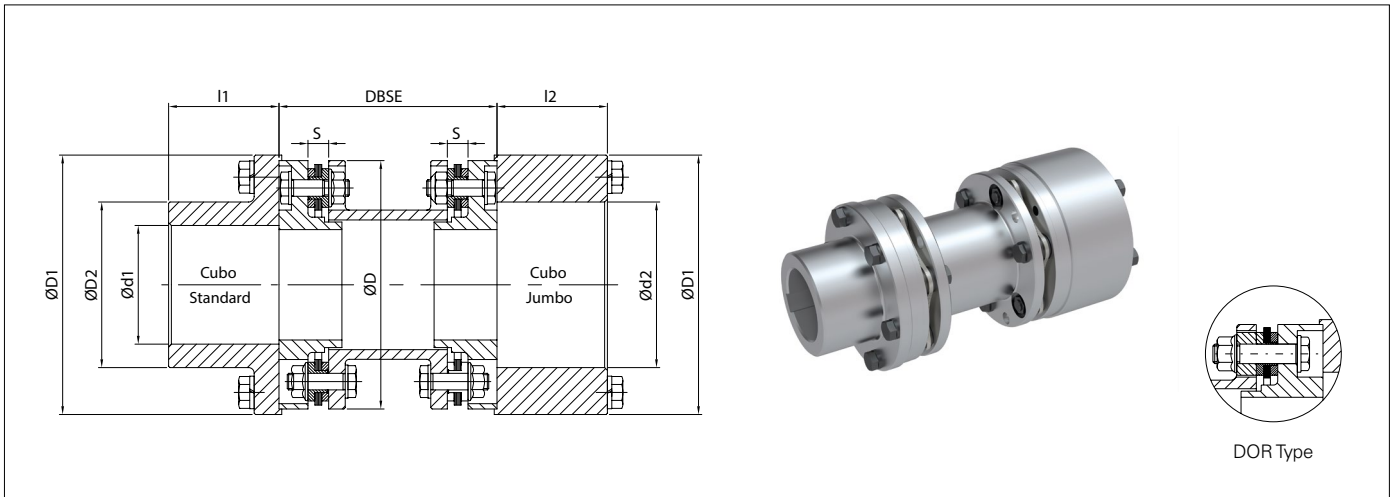

Designation example: **DO-110-6, DBSE = 140 mm, max speed (rpm), standard or jumbo hubs.**

SIZE	TN NOMINAL (1)	TP MAX (1)	n MAX (2)	GENERAL DIMENSIONS (mm)								WEIGHT (5) kg	MASSMOMENT OF INERTIA (5) J (kgm ²)
				D	D1	D2	d1 Max. (3)	d2 Max. (3)	l1-l2	DBSE (4)	S		
DO-6	Nm	Nm	rpm										
90-6	240	480	15920	90	94	60	43	60	40	79	7,5	3,6	0,005
110-6	575	1150	13020	110	115	73	52	75	50	108	8,4	5,4	0,009
132-6	1100	2200	10850	132	139	95	67	90	60	110	8,4	10	0,024
158-6	2000	4000	9070	158	165	112	80	105	70	140	11,2	18	0,062
185-6	3300	6600	7740	185	193	134	95	125	80	160	14	28	0,13
202-6	4600	9200	7090	202	210	144	102	135	90	185	15,5	38	0,22
228-6	7000	14000	6280	228	236	160	115	150	100	205	17,5	55	0,41
255-6	10200	20400	5620	255	263	175	125	170	115	250	20,5	72	0,65
278-6	14200	28400	5150	278	286	195	140	185	125	255	21,2	101	1,12
302-6	20000	40000	4740	302	310	217	155	200	135	280	24,4	133	1,72
325-6	25000	50000	4410	325	333	240	170	215	145	285	26	160	2,35
345-6	31000	62000	4150	345	355	255	180	230	155	320	28,2	193	3,26
380-6	42300	84600	3770	380	390	295	210	250	170	345	32	262	5,32
410-6	57100	114200	3490	410	420	315	225	270	185	375	33,2	335	8,02
440-6	73500	147000	3260	440	450	330	235	290	195	415	36,4	397	10,8
475-6	92000	184000	3020	475	485	355	250	312	210	450	38,2	505	16
505-6	117000	234000	2840	505	515	385	275	332	230	490	42	631	23

- Puller holes can be made upon request.
- Set screws can be included upon request.

- Adapted hub length available upon request.
- DOR overload bushings available upon request.

- JS nuts available upon request.
- Certified according to ATEX 94/9 EC (ATEX 95), categories 2G/2D.



- (1) The torque of the coupling does not include the connection transmission capacity.
- (2) n MAX speed for balanced couplings. For higher speeds contact Jaure® coupling engineering. For long DBSE, please check Figure 4 at page 17.

- (3) Max. allowable bore for couplings with DIN 6885/1 keys. For other types of keys or connections please contact Jaure® coupling engineering.

- (4) DBSE is distance between shaft ends. Different DBSE to be specified by customer.
- (5) Weight and moment of inertia based on maximum bores.

DO-8: DROP-OUT, 8 BOLTS, ACCORDING TO API 610 ON DEMAND

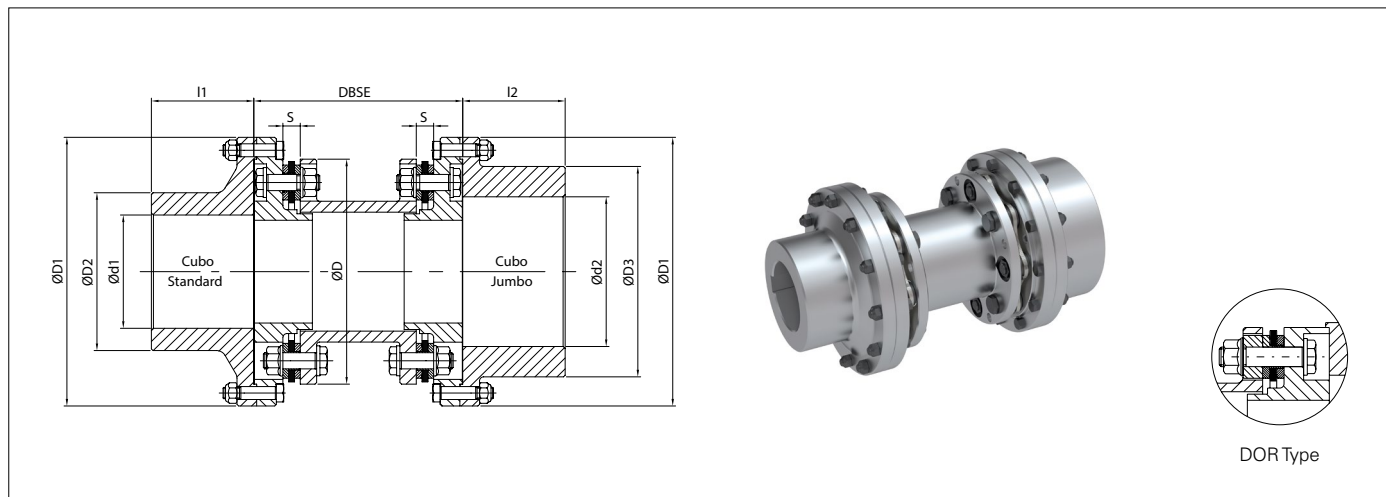

Designation example: **DO-325-8, DBSE = 350 mm, max speed (rpm), standard or jumbo hubs.**

SIZE	TN NOMINAL (1)	TP MAX (1)	n MAX (2)	GENERAL DIMENSIONS (mm)									WEIGHT (5)	MASSMOMENT OF INERTIA (5)
				D	D1	D2	D3	d1 max. (3)	d2 max. (3)	I1-I2	DBSE (4)	S		
DO-8	Nm	Nm	rpm	D	D1	D2	D3	d1 max. (3)	d2 max. (3)	I1-I2	DBSE (4)	S	kg	J (kgm ²)
278-8	20000	40000	5150	278	332	195	260	140	185	125	255	21,2	130	1,69
302-8	30000	60000	4740	302	356	217	285	155	200	135	280	24,4	164	2,45
325-8	37000	74000	4410	325	400	240	305	170	215	145	285	26	213	3,95
345-8	46000	92000	4150	345	417	255	322	180	230	155	320	28,2	250	5,20
380-8	63000	126000	3770	380	455	295	360	210	255	170	345	32	325	7,80
410-8	86000	172000	3490	410	498	315	390	225	275	185	375	33,2	412	11,7
440-8	110000	220000	3260	440	528	330	420	235	300	195	415	36,4	480	15,2
475-8	138000	276000	3020	475	585	355	450	250	320	210	450	38,2	632	24,3
505-8	175000	350000	2840	505	615	385	480	275	340	230	490	42	794	34,4
540-8	220000	440000	2650	540	670	415	508	295	360	240	560	46	840	42,2
570-8	259000	518000	2510	570	702	450	540	320	385	250	605	51,6	950	51,1
605-8	315000	630000	2370	605	727	460	565	325	400	265	620	53,2	1120	64,5

- Puller holes can be made upon request.
- Set screws can be included upon request.

- Adapted hub length available upon request.
- DOR overload bushings available upon request.

- JS nuts available upon request.
- Certified according to ATEX 94/9 EC (ATEX 95), categories 2G/2D.



(1) The torque of the coupling does not include the connection transmission capacity.

(2) n MAX speed for balanced couplings. For higher speeds contact Jaure® coupling engineering. For long DBSE, please check Figure 4 at page 17.

(3) Max. allowable bore for couplings with DIN 6885/1 keys. For other types of keys or connections please contact Jaure® coupling engineering.

(4) DBSE is distance between shaft ends. Different DBSE to be specified by customer.

(5) Weight and moment of inertia based on maximum bores.

DOM-6: DROP-OUT MODULAR, 6 BOLTS, ACCORDING TO API 610 ON DEMAND

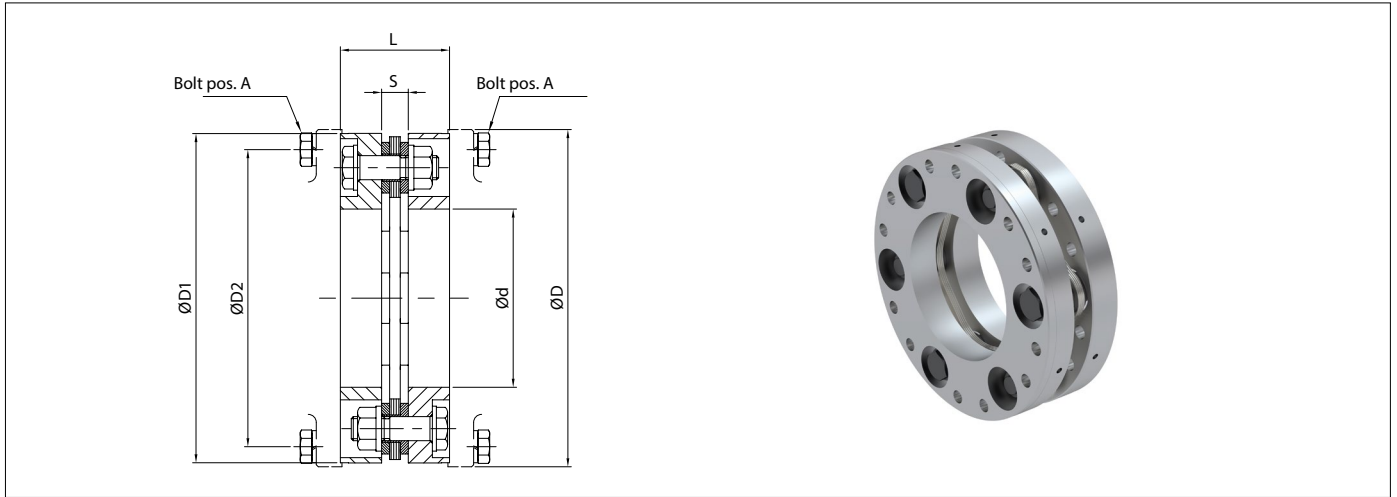

Designation example: **DOM - 202 -2**

SIZE	TN NOMINAL (1)	TP MAX (1)	n MAX (2)	GENERAL DIMENSIONS (mm)						BOLT DATA pos.A (3)			WEIGHT	MASS MOMENT OF INERTIA
				d	D	D1	D2	L	S	Grade	Z-M	Nm		
DOM-6	Nm	Nm	rpm	d	D	D1	D2	L	S	Grade	Z-M	Nm	Kg	J (kgm ²)
90-6	240	480	15920	45	94	90	78	28,5	7,5	12,9	12-M6	15	0,7	0,001
110-6	575	1150	13020	55	115	110	96	39	8,4	12,9	12-M8	35	1,6	0,003
132-6	1100	2200	10850	70	139	132	118	39	8,4	12,9	12-M8	35	2,2	0,006
158-6	2000	4000	9070	82	165	158	140	50	11,2	12,9	12-M10	69	4,1	0,016
185-6	3300	6600	7740	96	193	185	165	58	14	12,9	12-M12	120	6,3	0,034
202-6	4600	9200	7090	105	210	202	180	65,5	15,5	12,9	12-M14	190	8,6	0,06
228-6	7000	14000	6280	109	236	228	200	73,5	17,5	12,9	12-M16	295	13	0,11
255-6	10200	20400	5620	121	263	255	225	90,5	20,5	12,9	12-M18	410	21	0,21
278-6	14200	28400	5150	150	286	278	245	92	21,2	12,9	12-M20	580	23	0,28
302-6	20000	40000	4740	168	310	302	268	101	24,4	12,9	12-M22	780	28	0,42
325-6	25000	50000	4410	180	325	325	290	102	26	12,9	12-M22	780	33	0,57
345-6	31000	62000	4150	190	355	345	305	111	28,2	12,9	24-M20	580	41	0,78
380-6	42300	84600	3770	210	390	380	345	126	32	12,9	24-M22	780	55	1,27
410-6	57100	114200	3490	222	420	410	370	136	33,2	12,9	24-M24	1000	71	1,9
440-6	73500	147000	3260	235	450	440	395	149	36,4	12,9	24-M27	1500	91	2,78
475-6	92000	184000	3020	270	485	475	425	163	38,2	12,9	24-M30	2000	113	4,16
505-6	117000	234000	2840	290	515	505	455	180	42	12,9	24-M30	2000	139	5,8

- JS nuts available upon request.
- Certified according to ATEX 94/9 EC (ATEX 95),  categories 2G/2D.

- (1) The torque of the coupling does not include the connection transmission capacity.
- (2) n MAX speed for balanced couplings. For higher speeds, contact Jaure® coupling engineering.
- (3) Tightening torque values dry. For lubricated, reduce values by 20%.

DOM-8: DROP-OUT MODULAR, 8 BOLTS, ACCORDING TO API 610 ON DEMAND

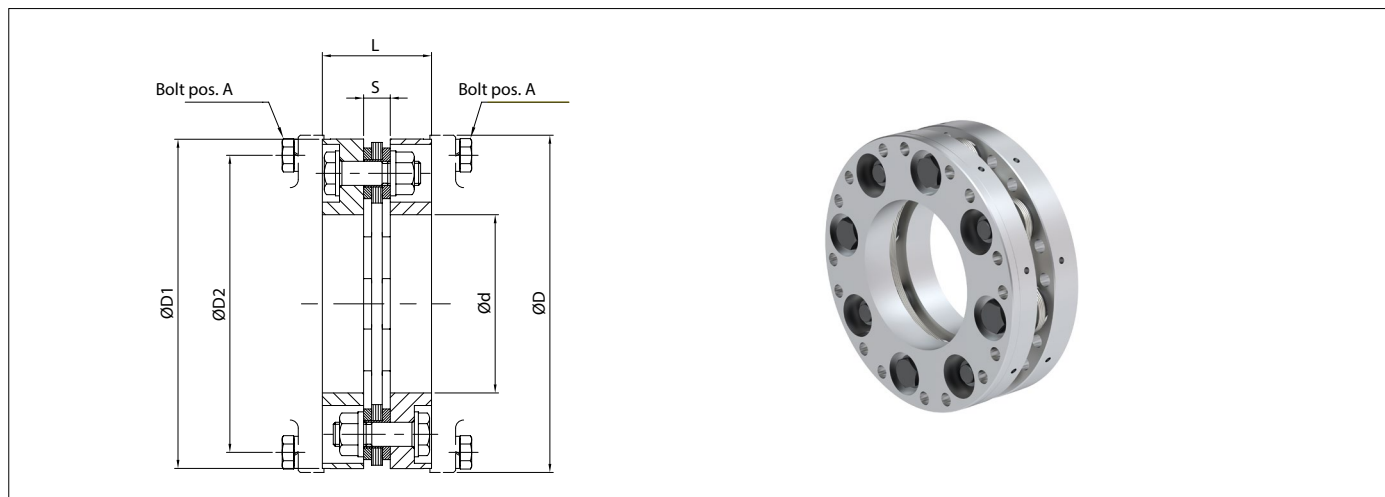

Designation example: **DOM - 410 - 8**

SIZE	TN NOMINAL (1)	TP MAX (1)	n MAX (2)	GENERAL DIMENSIONS (mm)						BOLT DATA pos.A (3)			WEIGHT Kg	MASS MOMENT OF INERTIA J (kgm ²)
				d	D	D1	D2	L	S	Grade	Z-M	Nm		
DOM-8	Nm	Nm	rpm	d	D	D1	D2	L	S	Grade	Z-M	Nm	Kg	J (kgm ²)
278-8	20000	40000	5150	150	292	284	258	92	21,2	10,9	32-M16	250	23	0,296
302-8	30000	60000	4740	168	315	307	277	101	24,4	10,9	32-M18	350	29	0,434
325-8	37000	74000	4410	180	338	330	300	102	26	10,9	32-M18	350	34	0,59
345-8	46000	92000	4150	190	358	350	317	111	28,2	10,9	32-M20	470	42	0,8
380-8	63000	126000	3770	210	395	385	350	126	32	10,9	32-M22	640	55	1,29
410-8	86000	172000	3490	222	435	425	385	136	33,2	10,9	32-M24	830	74	2,1
440-8	110000	220000	3260	235	469	459	415	149	36,4	10,9	32-M27	1200	99	3,23
475-8	138000	276000	3020	270	495	485	440	163	38,2	10,9	32-M27	1250	116	4,39
505-8	175000	350000	2840	290	548	538	488	180	42	10,9	32-M30	1700	163	7,49
540-8	220000	440000	2650	300	585	573	520	190	46	10,9	32-M33	2200	186	9,56
570-8	259000	518000	2510	320	606	594	535	206	51,6	10,9	32-M33	2200	219	12,2
605-8	315000	630000	2370	330	645	635	570	218	53,2	10,9	32-M36	2950	332	21

➤ JS nuts available upon request.

➤ Certified according to ATEX 94/9 EC (ATEX 95),  categories 2G/2D.

(1) The torque of the coupling does not include the connection transmission capacity.

(2) n MAX speed for balanced couplings. For higher speeds, contact Jaure® coupling engineering.

(3) Tightening torque values dry. For lubricated, reduce values by 20%.

DOI-AC-6: DROP-OUT INVERTED, 6 BOLTS, ACCORDING TO API 610 ON DEMAND

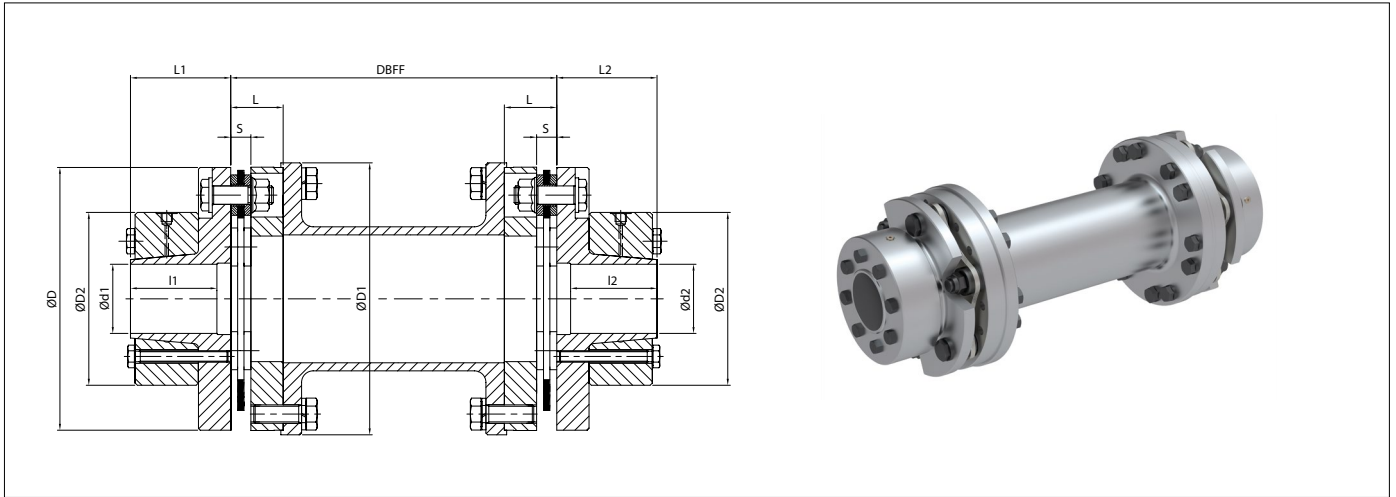

Designation example: **DOI - AC - 185 - 6, DBFF = 250mm**

SIZE	TN NOMINAL (1)	TP MAX (1)	n MAX (2)	GENERAL DIMENSIONS (mm)									WEIGHT (5)	MASSMOMENT OF INERTIA (5)
				D	D1	D2	d1-d2 max. (3)	I1-I2 (6)	L1-L2 (6)	DBFF (4)	L	S		
DOI-AC-6	Nm	Nm	rpm	D	D1	D2	d1-d2 max. (3)	I1-I2 (6)	L1-L2 (6)	DBFF (4)	L	S	kg	J (kgm ²)
90-6	240	480	15920	90	94	85	20	47	53	92	18	7,5	5,9	0,006
110-6	575	1150	13020	110	115	110	25	54	60	119	23,7	8,4	11	0,018
132-6	1100	2200	10850	132	139	110	30	54	60	139	23,7	8,4	13	0,027
158-6	2000	4000	9070	158	165	130	40	60	68	163	30,6	11,2	22	0,067
185-6	3300	6600	7740	185	193	140	45	66	76	184	36	14	31	0,13
202-6	4600	9200	7090	202	210	140	50	70	79	208	40,5	15,5	36	0,18
228-6	7000	14000	6280	228	236	150	60	75	87	230	45,5	17,5	50	0,31
255-6	10200	20400	5620	255	263	160	70	72	80	266	55,5	20,5	69	0,57
278-6	14200	28400	5150	278	286	180	80	78	85	289	56,6	21,2	82	0,81
302-6	20000	40000	4740	302	310	180	90	92	98	311	62,7	24,4	100	1,19
325-6	25000	50000	4410	325	333	225	100	105	119	330	64	26	136	1,77
345-6	31000	62000	4150	345	355	245	110	105	126	353	69,6	28,2	168	2,5
380-6	42300	84600	3770	380	390	254	120	110	136	390	79	32	211	3,83
410-6	57100	114200	3490	410	420	280	130	130	156	422,8	84,6	33,2	285	6,03
440-6	73500	147000	3260	440	450	300	140	135	166	446,6	92,7	36,4	356	8,7
475-6	92000	184000	3020	475	485	330	150	150	182	482,8	100,6	38,2	457	13
505-6	117000	234000	2840	505	515	355	160	165	199	532	111	42	568	18,3

- Adapted hub length available upon request.
- JS nuts available upon request.

- Certified according to ATEX 94/9 EC (ATEX 95), categories 2G/2D. 

- (1) The torque of the coupling does not include the connection transmission capacity.
 (2) n MAX speed for balanced couplings. For higher speeds, contact Jaure® coupling engineering. For long DBFF, please check Figure 4 at page 17.

- (3) Max. allowable bores for standard design. For bigger bores, please contact Jaure® coupling engineering.
 (4) DBFF is distance between flange faces, not between shafts. Different DBFF to be specified by customer.

- (5) Weight and moment of inertia based on maximum bores.
 (6) Available shaft length for connection should be within I1 (min. shaft penetration) to L1 (Max. shaft penetration); and I2 to L2 respectively.

DOI-AC-8: DROP-OUT INVERTED, 8 BOLTS, ACCORDING TO API 610 ON DEMAND

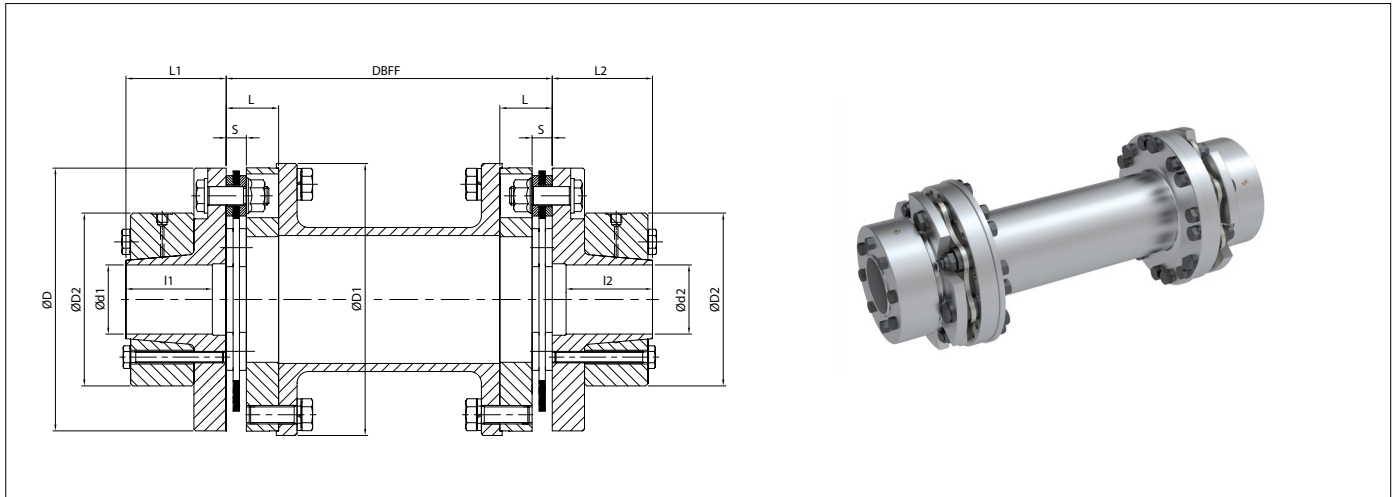

Designation example: **DOI - AC - 475 - 8, DBFF = 500mm**

SIZE	TN NOMINAL (1)	TP MAX (1)	n MAX (2)	GENERAL DIMENSIONS (mm)									WEIGHT (5)	MASSMOMENT OF INERTIA (5)
				D	D1	D2	d1-d2 max. (3)	I1-I2 (6)	L1-L2 (6)	DBFF (4)	L	S		
DOI-AC-8	Nm	Nm	rpm	D	D1	D2	d1-d2 max. (3)	I1-I2 (6)	L1-L2 (6)	DBFF (4)	L	S	kg	J (kgm ²)
278-8	20000	40000	5150	278	292	180	90	92	96	289	56,6	21,2	86	0,87
302-8	30000	60000	4740	302	315	225	100	105	119	311	62,7	24,4	125	1,47
325-8	37000	74000	4410	325	338	245	110	105	123	330	64	26	147	1,99
345-8	46000	92000	4150	345	358	254	120	110	130	353	69,6	28,2	177	2,70
380-8	63000	126000	3770	380	395	280	130	130	151	390	79	32	252	4,66
410-8	86000	172000	3490	410	435	330	150	150	172	423	84,6	33,2	360	8,11
440-8	110000	220000	3260	440	469	355	160	160	187	447	92,7	36,4	456	12
475-8	138000	276000	3020	475	495	370	170	175	202	483	100,6	38,2	546	16,1
505-8	175000	350000	2840	505	548	390	180	185	219	532	111	42	701	24,6
540-8	220000	440000	2650	540	585	415	190	200	233	560	118	46	829	33
570-8	259000	518000	2510	570	606	425	200	215	251	605	129	51,6	961	41,3
605-8	315000	630000	2370	605	645	435	220	235	272	639	135,6	53,2	1158	56,5

- Adapted hub length available upon request.
- JS nuts available upon request.

- Certified according to ATEX 94/9 EC (ATEX 95), categories 2G/2D.



- (1) The torque of the coupling does not include the connection transmission capacity.
- (2) n MAX speed for balanced couplings. For higher speeds, contact Jaure® coupling engineering. For long DBFF, please check Figure 4 at page 17.

- (3) Max. allowable bores for standard design. For bigger bores, please contact Jaure® coupling engineering.
- (4) DBFF is distance between flange faces, not between shafts. Different DBFF to be specified by customer.

- (5) Weight and moment of inertia based on maximum bores.
- (6) Available shaft length for connection should be within I1 (min. shaft penetration) to L1 (Max. shaft penetration); and I2 to L2 respectively.

LAMIDISC® COUPLING WITH COMPOSITE SHAFTS (JCFS / JGFS)

Experience, manufacturing programs, innovation and close cooperation with leading international companies enabled us to introduce composite drive shafts. Several applications such as cooling towers, machine tools and marine drives require our Lamidisc couplings to be combined with composite drive shafts, both in carbon fiber (JCFS) and glass fiber (JGFS).

Jaure® Composite Drive Shafts



Jaure® carbon fiber drive shafts provide following features:

- Low weight: depending on the drive shaft configuration, steel shafts are approximately 50-70% heavier.
- Easy installation and maintenance: there are longer distances between the bearings, which reduces their quantity and simplifies the shaft line layout.
- Temperature stability (almost null thermal expansion) avoids misalignment concerns on long drive shafts.
- Corrosion resistance: As carbon fiber tubes are not affected by corrosion or wear, no maintenance is required and service life is longer.
- JGFS glass fiber drive shafts additionally provide electrical insulating properties.

Various applications:



Marine



Cooling tower



Cooling tower



Machine Tools

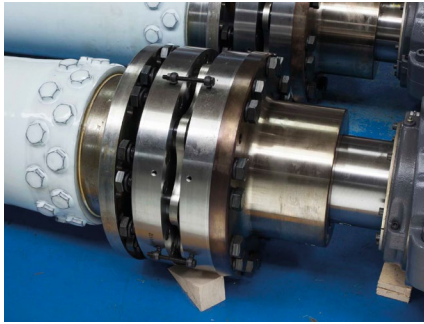

Marine



Test Bench



Wind

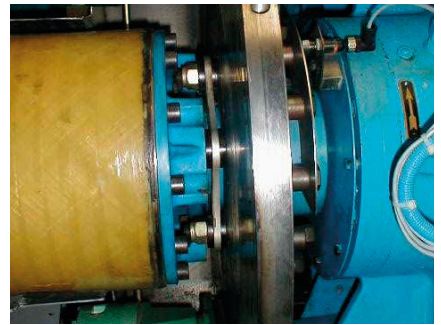

Wind

Fire protection of the composite tubes against fire is available on demand. Contact Jaure® coupling engineering department for further information.

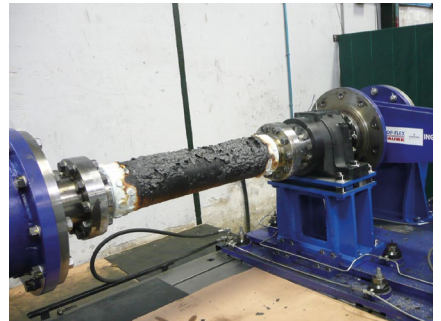
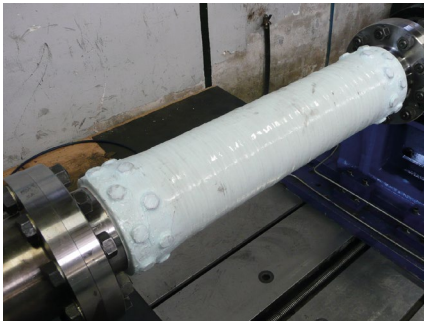

Fatigue validation at Regal Rexnord facility before and after furnace testing

AC: CLAMPING SET

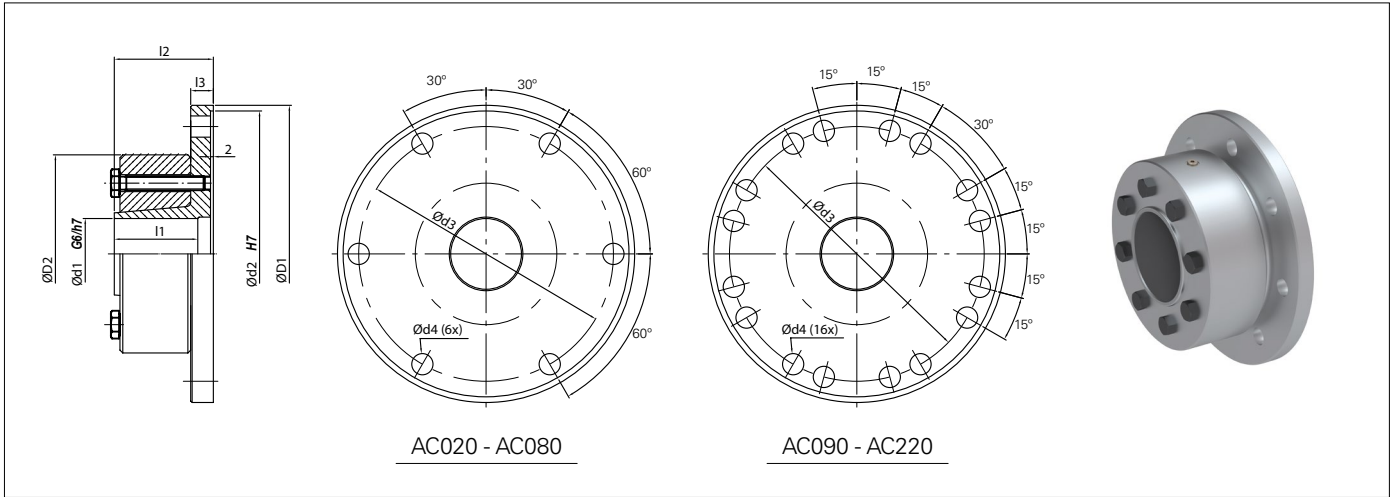

Designation example: **AC - 100 G6 / h7**

SIZE	SHAFT DIAMETER (mm) (2)	TN NOMINAL (1)	GENERAL DIMENSIONS (mm)								WEIGHT (4)	MASS MOMENT OF INERTIA (4)
			D1	d2	l1 (3)	l2 (3)	l3	D2	d3	d4		
020	20	267	120	116	46	54	14	85	102	6,6	2,6	0,003
	25	535	159	152	54	60	15	110	138	9	5	0,011
30	920	4,9									0,011	
040	35	1470	193	186	59	66	17	130	168	11	7,8	0,026
	40	2200									7,7	0,026
050	45	3120	210	202	65	73	19	140	180	15	9,9	0,04
	50	4310									9,7	0,04
060	55	5720	236	228	71	77	18	150	200	17	12	0,06
	60	7450									12	0,06
070	65	9470	263	255	72	82	22	160	225	20	15	0,11
	70	11770									15	0,1
080	75	13950	286	278	78	87	22	180	245	22	19	0,15
	80	16720									19	0,15
090	85	19220	292	284	92	98	22	180	258	17	21	0,17
	90	22720									20	0,17
100	95	29550	315	307	98	105	24	225	277	19	32	0,31
	100	34020									31	0,31
110	105	37050	338	330	102	109	24	245	300	19	39	0,44
	110	41970									38	0,44
120	115	46300	358	350	108	115	26	254	317	22	44	0,56
	120	51770									43	0,56
130	125	63550	395	385	125	133	29	280	350	24	62	0,96
	130	70570									61	0,96
140	135	79520	435	425	132	141	32	300	385	25	78	1,45
	140	87450									77	1,45
150	145	93000	455	445	144	152	32	330	405	25	97	1,99
	150	101620									96	1,99
160	155	110000	469	459	156	165	35	355	415	30	119	2,69
	160	119500									117	2,69
170	165	140100	495	485	168	178	38	370	440	30	140	3,52
	170	151170									138	3,51
180	175	185070	548	538	180	191	41	390	488	32	174	5,17
	180	201370									172	5,16
190	185	218650	585	573	196	207	44	415	520	35	214	7,23
	190	236850									212	7,22
200	195	256050	606	594	210	222	47	425	540	35	241	8,72
	200	270070									238	8,7
220	210	311950	645	633	228	240	50	435	570	38	275	11,2
	220	350450									269	11,1

- Adapted hub length available upon request.
- JS nuts available upon request.
- Certified according to ATEX 94/9 EC (ATEX 95)

- (1) Maximum transmissible torque capacity, estimated with coefficient of friction $\mu = 0,18$ between shaft & clamping hub. For AC selection, please, refer to catalogue selection procedure chapter.
- (2) Given dimensions for specific bore/shaft diameters. For different bore/shaft diameters, please, contact Jaure® coupling engineering.
- (3) Available shaft length for connection should be within l1 (min. shaft penetration) to "l2 - 2 mm" (Max. shaft penetration)
- (4) Weight and mass moment of inertia based on the indicated specific bore diameters.

JS NUT

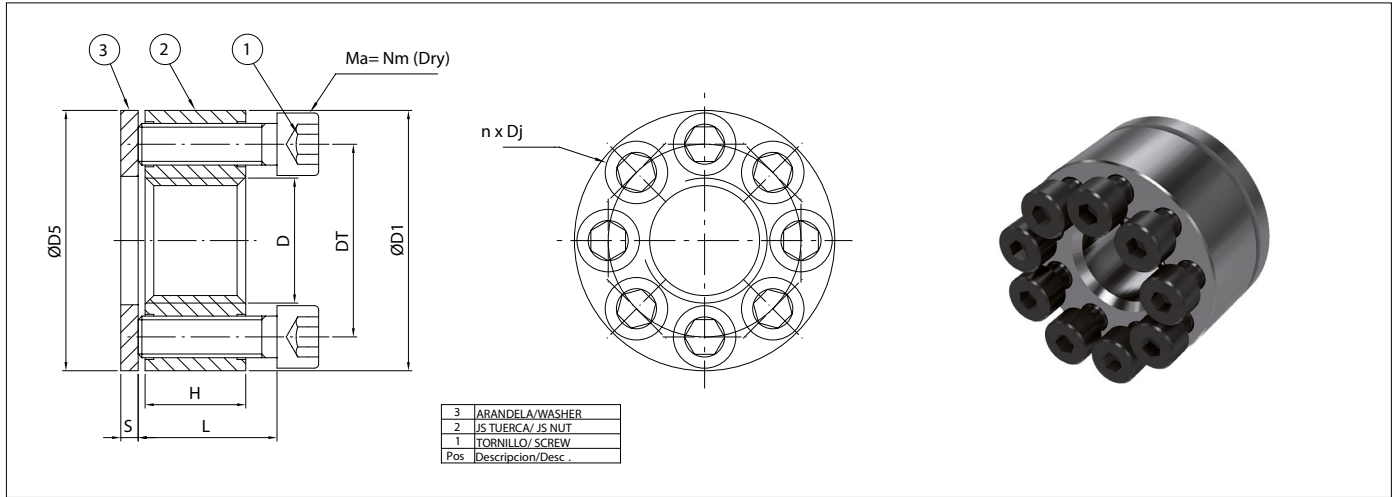

Designation example: **JS -T10 - M48 x 5**

The Jaure® JS nut is a pretensioning device which has multiple screws located on a common pitch circle diameter that are intended to create an axial thrust by applying a small input torque. Main benefits are the low tightening torque required, reduced installation time and personnel safety.

It was first introduced in combination with Lamidisc® disc pack couplings but is also available alone or in combination with other types of Jaure couplings. It can also be delivered on demand with 3.2 certificate of Marine Classification Societies.

The JS super nut is composed of three elements: nut body, jackbolts and hardened washer.

SIZE	D1=Ø5	H	DT	S	L	PRETENSIONING SCREW SIZE	PRETENSIONING SCREW QUANTITY	JS-T8		JS-T10	
								TIGHTENING TORQUE	PRELOAD	TIGHTENING TORQUE	PRELOAD
JS Nut	mm	mm	mm	mm	mm	Dj	n	Nm (Dry)	kN	Nm (Dry)	kN
M22 x 2,5	48	18	35	5	33	M8	7	33	154	43	200
M24 x 3	50,5	19	37,5	5	38	M8	8	34	181	43	229
M27 x 3	56,5	22	42,5	5	38	M8	9	38	228	43	258
M30 x 3,5	62,5	24	46	5	45	M10	7	74	277	84	315
M33 x 3,5	66	26	50	5	45	M10	9	70	338	84	405
M36 x 4	75	29	55,5	5	52	M12	7	124	400	152	491
M39 x 4	78	31	58,5	5	52	M12	8	127	469	152	561
M42 x 4,5	81	34	61,5	5	57	M12	9	130	540	152	631
M45 x 4,5	88	36	68,5	6	57	M12	11	124	630	152	772
M48 x 5	93	38	70,5	6	59	M14	9	198	711	252	905
M52 x 5	97	42	74,5	6	64	M14	10	212	846	252	1006
M56 x 5,5	108	45	82	6	71	M16	9	318	996	371	1163
M60 x 5,5	118	48	89	8	78	M18	8	458	1141	544	1355
M64 x 6	122	59	93	8	88	M18	10	417	1299	544	1694
M68 x 6	130	59	101	8	88	M18	11	434	1487	544	1864

► It is recommended that JS nut of series 'JS-T8' is to be used for main bolt of grade 8.8 and 'JS-T10' series is to be used for main bolt of grade 10.9

**OTHER
INFORMATION,
LAMIDISC[®]
COUPLING
DESIGNS &
REFERENCES**

SHAFT CONNECTION TYPES

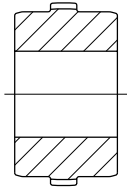

A00
PILOT

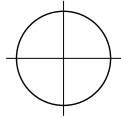
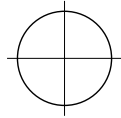

A01
CYLINDRICAL

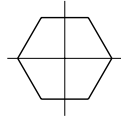

A02
HEXAGONAL

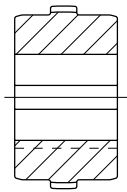

B01
ONE KEYWAY

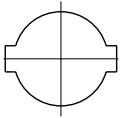
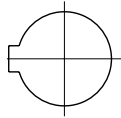

B02
TWO KEYWAYS
AT 180°

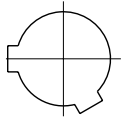

B03
TWO KEYWAYS
AT 120°

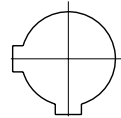

B04
TWO KEYWAYS
AT 90°

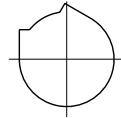

B05
TWO TANGENCIAL
KEYWAYS AT 120°

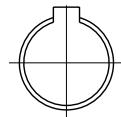
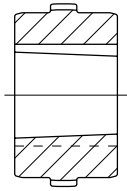

C01
CONICAL BORE
ONE STRAIGHT
KEYWAY

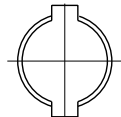

C02
CONICAL BORE
TWO STRAIGHT
KEYWAYS

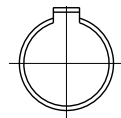
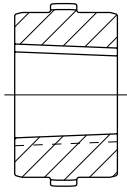

D01
CONICAL BORE
ONE TAPERED
KEYWAY

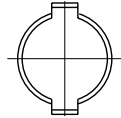

D02
CONICAL BORE TWO
TAPERED KEYWAYS

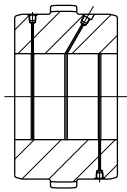

E01
SHRINK FIT

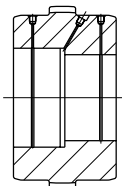

E02
SHRINK FIT
WITH TWO
DIAMETERS

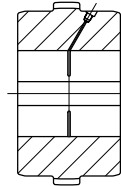

E03
SHRINK FIT
AND KEYWAY

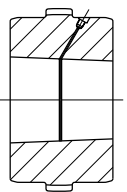

F01
TAPERED
SHRINK FIT

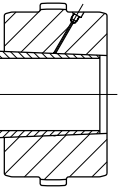

F02
WITH
CONICAL
SLEEVE

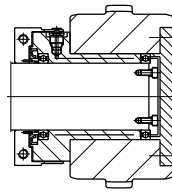

F03
WITH
SAFESET®*

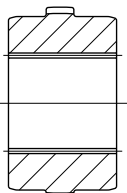

G01
ACCORDING
DIN 5480

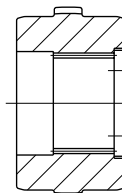

G02
ACCORDING
DIN 5480
WITH CENTERING
DIAMETER

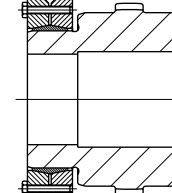

G03
WITH
CLAMPING
RING

*SAFESET is believed to be the trademark and/or trade name of Voith Turbo Safeset AB, and is not owned or controlled by Regal Rexnord Corporation.

RECOMMENDATIONS FOR SHAFT/BORE FITS

The following recommendations, according to ISO, are given for shaft/bore fits.

TYPE OF FIT	SHAFT TOLERANCES	BORE TOLERANCES
Interference fits with parallel keyway	h 6	S 7
	k 6	M 7
	m 6	K 7
	n 6	J 7
	p 6	H 7
Shrink fits* without parallel key	u 6	H 7
	v 6	
	x 6	

* The stresses on the hub must be checked.

For other types of connection, please consult our Engineering Department. For one keyway, a keyway tolerance width ISO P9 is recommended. For double keyway ISO JS9 is recommended.

LAMIDISC® COUPLING DESIGNS

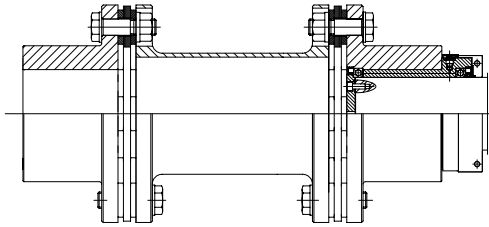

Type SXST-B. With Safeset® safety element.

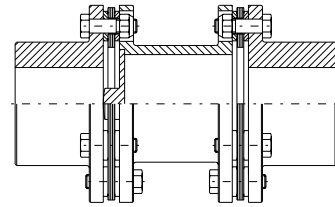

Type SXV. Vertical installation.

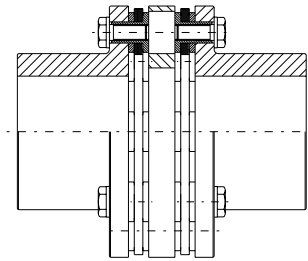

Type SC. Short distance connection.

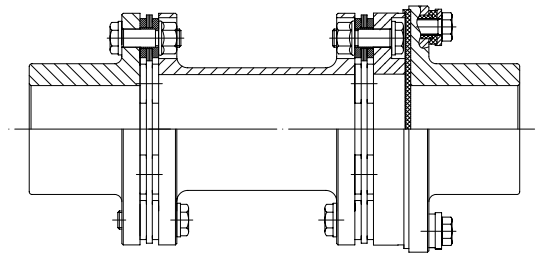

Type SXAE. With electrical insulation.

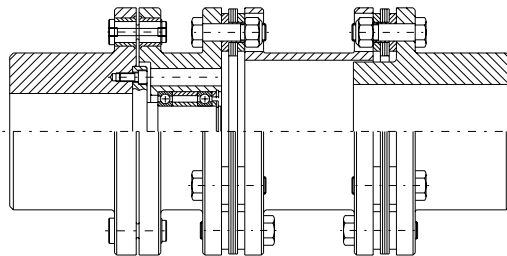

Type SXBR. Safety elements with shear pins.

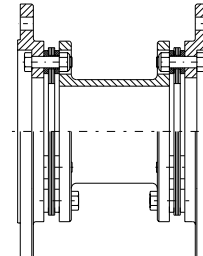

Type SXP. With flange adaptors.

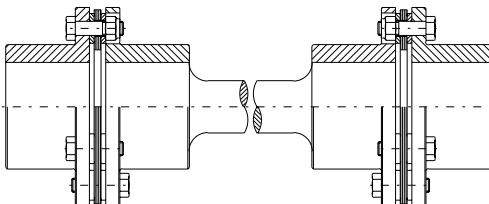

Type SDT. With floating shaft.

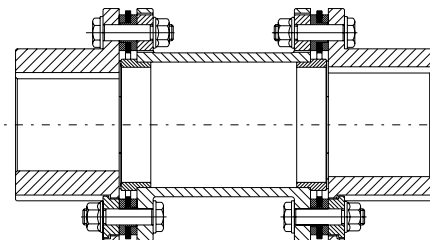

Type SXL . Limited end float.

**SAFESET is believed to be the trademark and/or trade name of Voith Turbo Safeset AB, and is not owned or controlled by Regal Rexnord Corporation.*

REQUIRED MINIMUM DATA

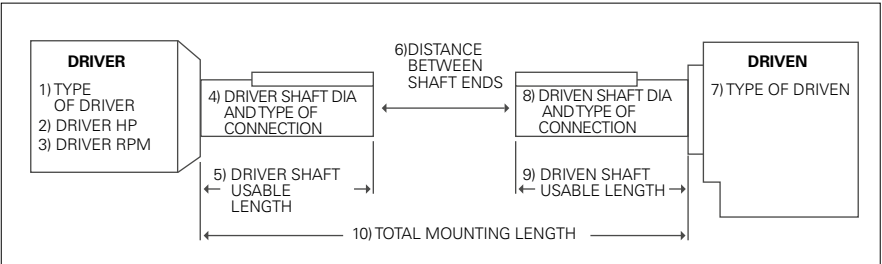

1. Type of Driver (Electric Motor, Combustion Engine, Gearbox, etc.):
2. Driver Power:
3. Operating Speed (rpm):
4. Driver Shaft Diameter:
Type of connection (hub to shaft connection):
5. Driver Usable Shaft Length:
(Measure from the end of the shaft to any obstruction)
6. Distance between shaft ends (DBSE):
7. Type of Driven Equipment:
8. Driven Shaft Diameter:
Type of connection (hub to shaft connection):
9. Driven Usable Shaft Length:
(Measure from the end of the shaft to any obstruction)
10. Total Mounting Length:
(Advise of any obstructions, walls, beams, guards, pipes, etc.)
11. Misalignment:
Angular:
Offset:
Axial:
12. Ambient Temperature:
13. Potential Excitation or Critical Frequencies:
(Torsional, Axial, Lateral)
14. Space Limitations:
15. Limitation on Coupling Generated Forces:
(Axial, Moments, Unbalance)
16. Balance Requirements:

LAMIDISC® COUPLING REFERENCES

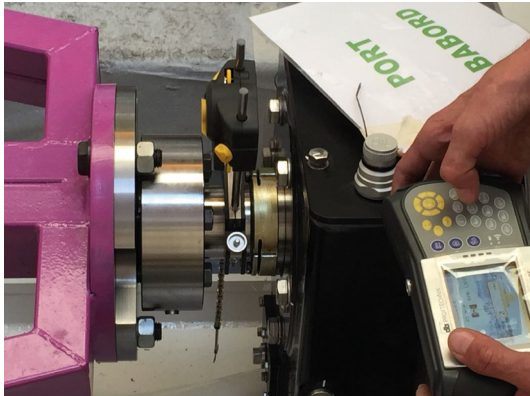

Coupling alignment during installation

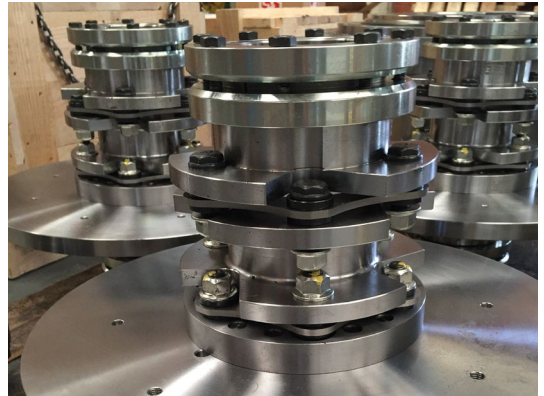

Lamidisc® coupling SX-FD-AC with clamping set and brake disc

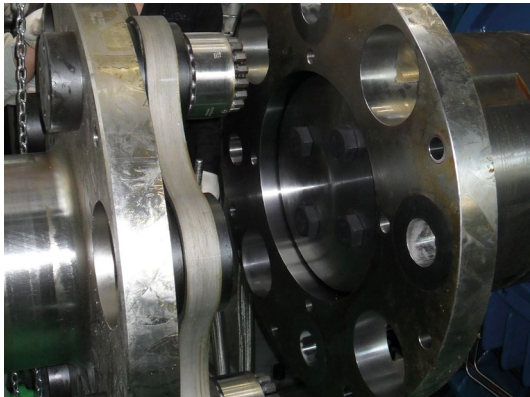

Lamidisc® coupling SXJS-950 for marine test bench



Lamidisc® coupling 1150-10 for marine propulsion

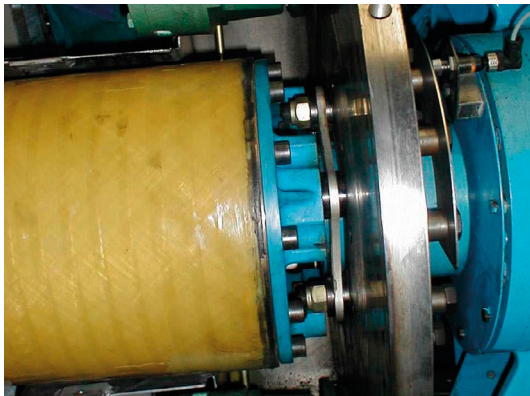

Lamidisc® coupling SX-FD-GF-302-6 for windmill application



Lamidisc® coupling with JGFS glass fiber shaft for wind industry

LAMIDISC® COUPLING REFERENCES

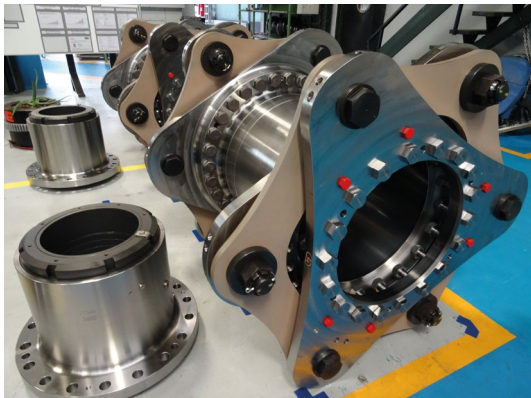

Lamidisc® coupling 1300-6 in combination with JHC-320 hydraulic coupling

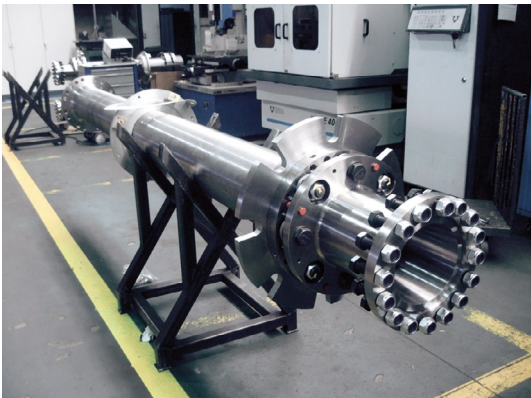

Lamidisc® coupling 380-8 with locking device and bulkhead seal for marine drive



Lamidisc® coupling 570-6 with JS Nut



Lamidisc® coupling 605-8 with JCFS composite shafts

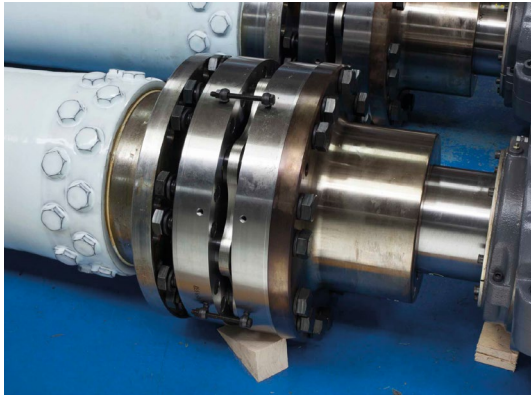

Lamidisc® coupling 505-8, JCFS-FP with fire protected composite

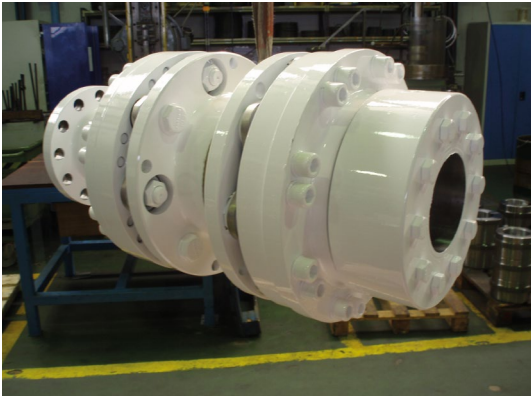

Lamidisc® coupling 410-8 AC with clamping set for marine drive



Lamidisc® coupling SXPR with adaptor flange



Lamidisc® coupling 410-8 with locking device



Lamidisc® coupling 380-8 JHSS with hollow steel spacer and bearings



Lamidisc® coupling 345-8 with clamping set



Lamidisc® coupling SXRFD-202-6 with brake disc for cranes



Detail of Lamidisc® coupling DO-675-8 SP with electrical insulation

LAMIDISC® COUPLING REFERENCES



SX type Lamidisc® coupling with long spacers for paper industry

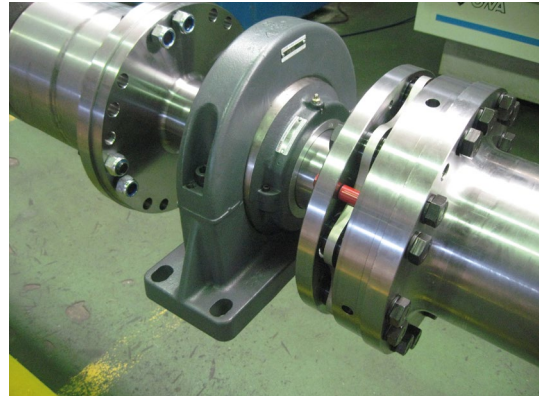

Lamidisc® coupling DOAE-475-8 with intermediate support bearing



Lamidisc® coupling SXFD with brake disc couplings for cranes



Lamidisc® coupling DOM modular kit



Lamidisc® coupling SU-JS-730-6-JHC-230 with hydraulic coupling



Glass fiber shaft for Lamidisc® coupling SXGF-228-6/3296mm for cooling towers with bonded and bolted joint

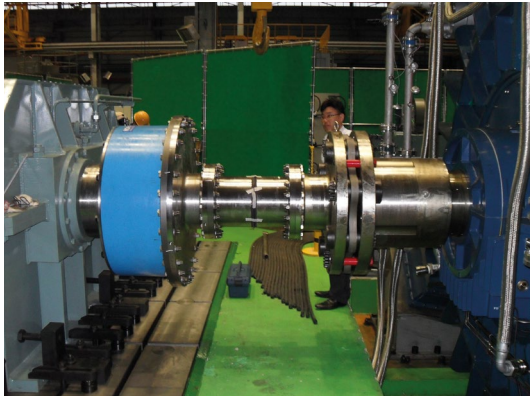

Lamidisc® coupling in combination with elastic MAX-C® coupling for test bench

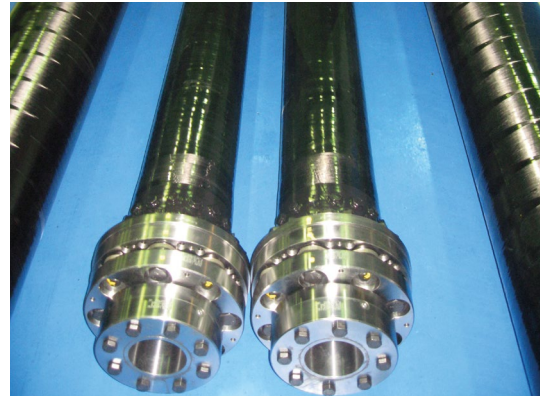

Lamidisc® coupling DOI-JCFS with composite driveshaft



Lamidisc® coupling SX-730-10 for mining applications



Lamidisc® coupling SX-JS with JS nut



Lamidisc® coupling DOM-410- 8

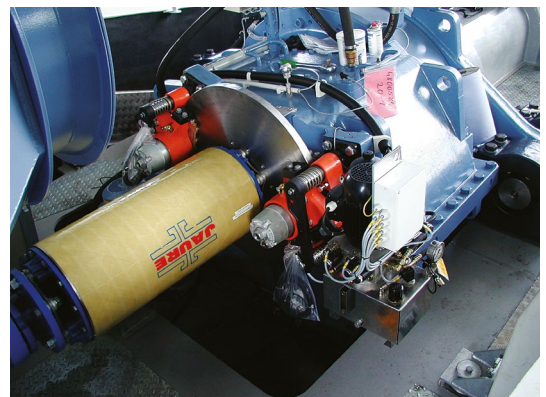

Lamidisc® coupling in combination with glass fiber shaft for electrical insulation

JAURE® COUPLING MANUFACTURING PROGRAM

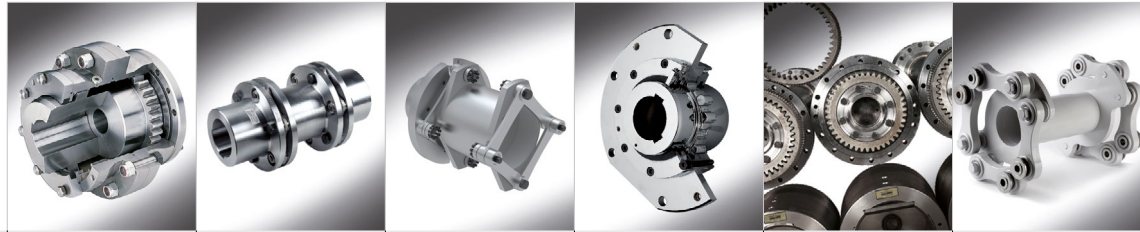

PRODUCT BRAND NAME	MT	LAMIDISC®	LAMILINK	TCB / TCB-HD	AL-S / AL-SD / ALD	IXILFLEX®
TYPE & DESCRIPTION	Gear	Disc pack	Metallic Link	Barrel (drum type)	Gear spindles	Elastic Link
INDUSTRY APPLICATION						
Metals & Heavy duty	•	•	•	•	•	
Minerals & Mills	•	•	•	•		
Crane & Hoisting	•	•	•	•		
Pulp & Paper	•	•	•			•
Petrochemical / Oil & Gas	•	•	•			
Cooling Towers		•	•			
Machine Tools		•	•			
Marine	•	•	•	•		•
Wind Turbines		•	•			•
Test Benches	•	•	•			•
Railway	•	•	•			•

COUPLINGS

						
COMPOLINK®	JAUFLEX®	RECORD	JCFS	JHC / JHC-HF	JFTL TORQUE LIMITER	JS NUT
Composite Link	Elastic	Grid / spring type	Composite Shafts	Hydraulic fit (shaft couplings)	Torque Limiter	Tensioner
	•	•		•	•	•
	•	•		•	•	•
	•	•			•	•
•	•	•	•			•
•	•	•	•			•
•			•			•
•	•		•			•
•	•		•	•	•	•
•	•	•	•	•	•	•
•			•	•		•
•					•	•

KOP-FLEX® & JAURE® COUPLINGS MANUFACTURING PROGRAM



PRODUCT BRAND NAME	MAX-C® COUPLING	HIGH PERFORMANCE PROGRAM			KOP-FLEX GREASE	SERVICE
TYPE & DESCRIPTION	HEAVY DUTY ELASTIC COUPLING	GEAR	DISC	DIAPHRAGM	GEAR COUPLING / SPINDLE GREASE	REPAIR & MAINTENANCE PROGRAM
INDUSTRY APPLICATION						
Metals & Heavy duty	•				•	•
Minerals & Mills	•				•	•
Crane & Hoisting	•				•	•
Pulp & Paper					•	•
Petrochemical / Oil & Gas	•	•	•	•	•	•
Cooling Towers					•	•
Machine Tools					•	•
Marine	•	•	•	•	•	•
Wind Turbines	•				•	•
Test Benches	•	•	•	•	•	•
Railway	•	•			•	•



RegalRexnord™

CHAIN & DRIVES®

WA LOCATIONS

Unit 1 / 45 Inspiration Drive, Wangara WA 6065
(08) 9303 4966

Unit 16 / 51-53 Kewdale Road, Welshpool WA 6106
(08) 6314 1155

support@chainanddrives.com.au

NSW LOCATION

Unit 7 / 70 Holbeche Road, Arndell Park NSW 2148
(02) 9674 8611

salesnsw@chainanddrives.com.au



A Mechanical Equipment Group Company