

FAG



Top-Laser SMARTY2.TARGET-DIGITAL

Digital target mark

User manual

SCHAEFFLER

Top-Laser SMARTY2.TARGET-DIGITAL

	Page
Features	
Safety guidelines	3
Scope of delivery.....	3
Description	
Laser unit.....	4
Digital target mark.....	4
Initial operation of devices	
Placement of the measuring device	5
Display.....	6
Differing pulley widths	6
Vertical alignment	7
Horizontal alignment.....	8
Adjusting the belt tension	
Accessories.....	9
Tolerances	9
Technical data	
Laser unit.....	10
Digital target mark.....	10
Maintenance	
.....	11

Top-Laser SMARTY2.TARGET-DIGITAL

Features The FAG Top-Laser SMARTY2.TARGET-DIGITAL is a measuring device for the alignment of belt pulleys, guide rollers and chain sprockets with a diameter greater than 60 mm at a measurement distance of up to 3 m.

Alignment results in fewer vibrations, and the wear on belts, belt pulleys, bearings and seals is reduced significantly.

Safety guidelines

Danger! Never look into the laser beam and never open the measuring device.

Never direct the laser beam into other people's eyes.

Do not use the laser in areas with an explosion risk.

Danger of injury from unintentional starting of the machine during measurement.

Before beginning the measurement, secure the main switch of the machine to prevent it from being switched on unintentionally.

Maintain these safety precautions until the measurement has been completed and the Top-Laser has been removed from the machine completely.

Caution! Neither Schaeffler nor its authorised distributors shall be liable for damage to machines or systems caused by incorrect use of the Top-Laser SMARTY2.TARGET-DIGITAL. Never open the measuring device and digital target mark (detector), as this will invalidate the warranty.

Scope of delivery

Equipment:

- Digital target mark
- 9-volt battery
- Transport and storage case.

Note The SMARTY2 measuring device must be available or ordered additionally (ordering designation: LASER-SMARTY2).

Top-Laser SMARTY2.TARGET-DIGITAL

Description The measuring device Top-Laser SMARTY2.TARGET-DIGITAL consists of the measuring device Top-Laser SMARTY2 and a digital target mark.

Laser unit

- ① Laser beam exit aperture
- ② Battery compartment
- ③ Magnetic area

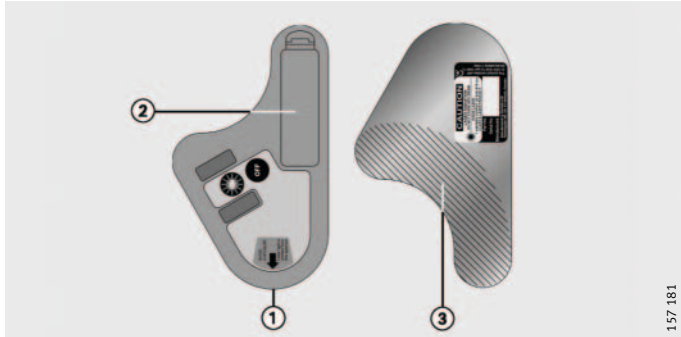

Figure 1
Measuring device,
front and rear

157 181

Digital target mark

- ① Detector apertures
- ② Magnetic areas
- ③ ON and OFF keys
- ④ Display
- ⑤ Battery compartment

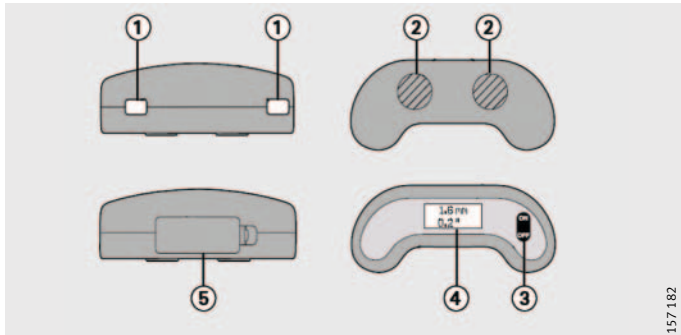

Figure 2
Digital target mark

157 182

Initial operation of devices

Switch on both devices. It is possible to switch from “mm” to “inches” by simultaneously pressing “ON” and “OFF” to the right of the digital target mark display.

Placement of the measuring device

Work steps:

- Remove the magnet protection plates.
- Fasten the measuring device to the fixed section of the machine, and the digital target mark to the adjustable section of the machine, *Figure 3*.
- Each of the magnetic areas must be fully in contact, *Figure 4*.
- The laser beam must hit the detector apertures of the digital target mark.

- ① Adjustable section of the machine
- ② Non-movable section of the machine

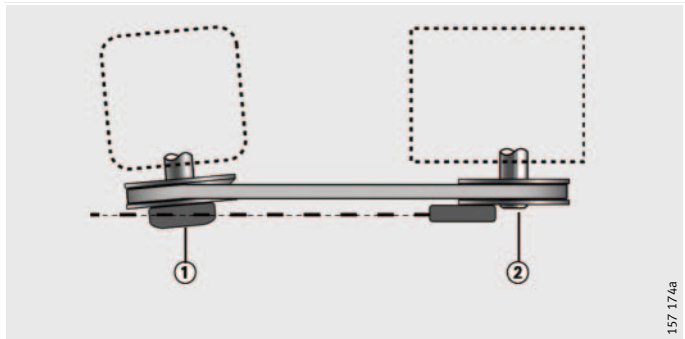

Figure 3
Placement of the device

157 174a

- ① The magnetic areas of the measuring device and the digital target mark must be fully in contact

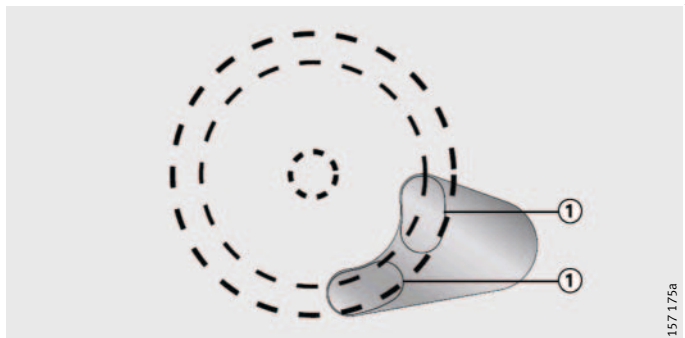

Figure 4
Correct contact of the magnetic area

157 175a

For non-magnetic belt pulleys, fasten the measuring device with double-sided adhesive strip.

Caution! Before applying the adhesive strip, clean the mounting surfaces. Apply the measuring device and target marks in a parallel arrangement.

Top-Laser SMARTY2.TARGET-DIGITAL

Display The display of the digital target mark shows the parallel misalignment at the top and the angle at the bottom, *Figure 5*.

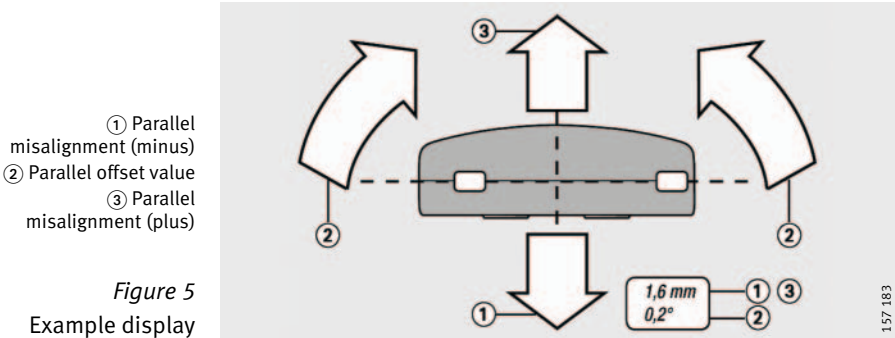

Differing pulley widths If the two pulleys to be aligned are not of the same width, *Figure 6*, the difference in width must be added to or subtracted from the zero value of the movable pulley.

The reference value (zero point) is the width of the pulley on the fixed part of the machine. The value obtained in this manner is the starting point for the correct measurement.

If, for example, the movable pulley is 1,0 mm thinner than the fixed one, then adjustment must be carried out until -1,0 mm appears on the display.

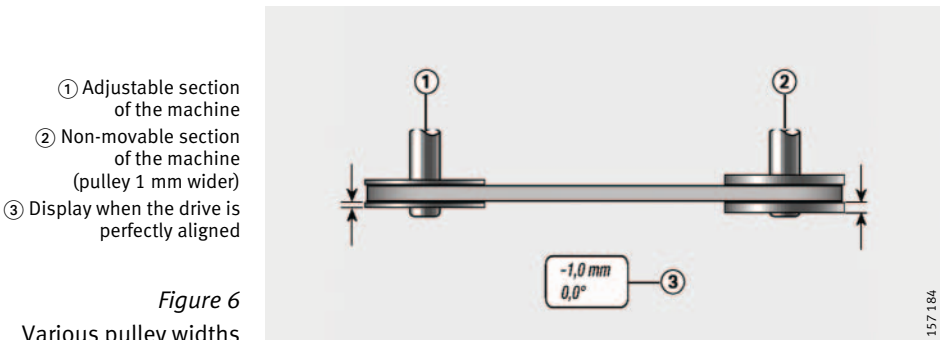

Vertical alignment To check the parallelism, apply the digital target mark vertically on the adjustable belt pulley, *Figure 7*.

The laser beam must hit both detector apertures. Correct any angular misalignment using shims under the machine feet.

If the belt pulleys are not in alignment (parallel misalignment), adjust the machine position using adjusting screws.

If the parallel misalignment is too large, the belt pulley must be moved axially on the shaft within the permissible tolerance.

- ① Area of the laser beam
- ② Digital target mark
- ③ Measuring device

Figure 7
Arrangement for vertical alignment

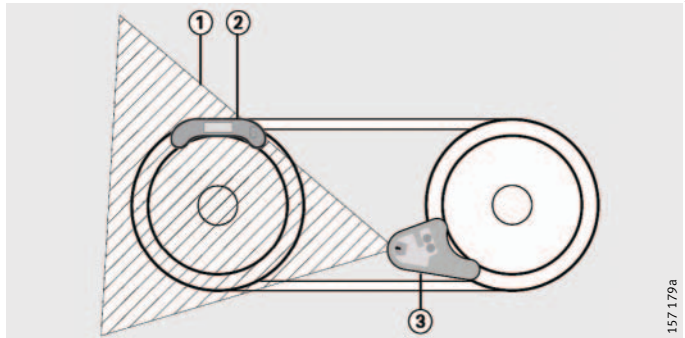

157 179a

Top-Laser SMARTY2.TARGET-DIGITAL

Horizontal alignment

Apply the digital target mark horizontally, *Figure 8*.

The laser beam must hit both detector apertures.

Align the adjustable machine section using shims.

Separate measurement operations are necessary to align a parallel misalignment and a height misalignment.

- ① Digital target mark
- ② Area of the laser beam
- ③ Measuring device

Figure 8

Arrangement for horizontal alignment

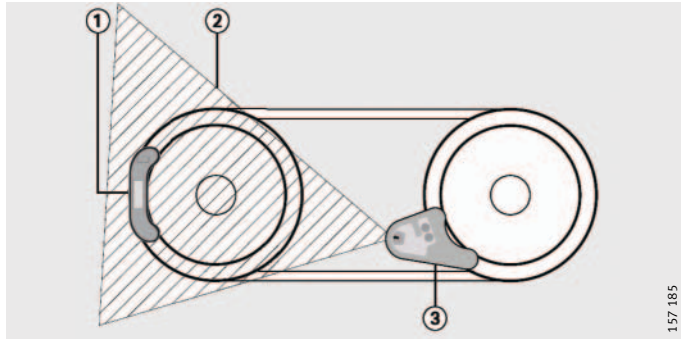

Adjusting the belt tension The recommended maximum tolerance is based on the belt type. The permissible angle deviation is $0,25^\circ$ in extreme cases. In case of doubt the value specified in the design handbook shall apply.

Accessories The measuring device FAG Top-Laser TRUMMY2 is recommended for measuring belt tension.

Tolerances

Tolerances – max. permissible misalignment

Angular misalignment					
α °	mm/m	α °	mm/m	α °	mm/m
0,1	1,75	0,4	6,98	0,8	13,96
0,2	3,49	0,5	8,73	0,9	15,71
0,25	4,44	0,6	10,47	1	17,45
0,3	5,24	0,7	12,22	–	–

Example An angular misalignment of $0,25^\circ$ with a distance of 0,1 m between the two belt pulleys corresponds to 0,44 mm and with a 1 m distance to 4,4 mm.

Top-Laser SMARTY2.TARGET-DIGITAL

Technical data

Laser unit

Laser

Laser unit	Technical data
Laser beam angle	78°
Laser class	2
Output power	< 1 mW
Laser wavelength	635 nm to 670 nm
Temperature range	-10 °C to +50 °C
Battery	1×AA R6 (1,5 V)
Battery life	8 h (continuous operation)
Housing materials	ABS plastic, aluminium
Dimensions (W×H×D)	145×86×30 mm
Mass	270 g

Digital target mark

Detector

Digital target mark (detector)	Technical data
Resolution displayed	mm or inches
Accuracy	max. ±1%
Measurement range	
Axial displacement	±3 mm
Angular misalignment	±3°
Accuracy	max. ±1%
Battery	1×LR61 (9 V)
Battery life	24 h (continuous operation)
Housing materials	ABS plastic
Dimensions (W×H×D)	135×56×46 mm
Mass	220 g
Calibration accuracy	Laser plane – Reference plane
Parallel misalignment	< 0,05°
Parallel offset value	< 0,2 mm

Maintenance If necessary, switch off the device and clean the laser aperture with a dry cloth only.
If the device is not used for a longer period, remove the battery.
Dispose of empty batteries in an environmentally-friendly manner.

**Schaeffler Technologies
GmbH & Co. KG**

Georg-Schäfer-Strasse 30
97421 Schweinfurt

Germany

Internet www.fag.com

E-Mail FAGinfo@schaeffler.com

In Germany:

Phone 0180 5003872

Fax 0180 5003873

From Other Countries:

Phone +49 9721 91-0

Fax +49 9721 91-3435

Every care has been taken to ensure the correctness of the information contained in this publication but no liability can be accepted for any errors or omissions.

We reserve the right to make technical changes.

© Schaeffler Technologies GmbH & Co. KG

Issued: 2014, August

This publication or parts thereof may not be reproduced without our permission.

BA 27 GB-D