

# İçindekiler

## Index

### Inhaltsverzeichnis

<b>Genel Bilgiler</b> General Info. Einführung	<b>İçindekiler</b>	<i>Index</i>	<b>Inhaltsverzeichnis</b>	
	<b>Sembollerin Açıklaması</b>	<i>Key of Symbols</i>	Erklärung der Bezeichnungen	01
	<b>Ürün Yelpazesi</b>	<i>Production Range</i>	Produktpalette	03
	<b>E Serisi Redüktörlerin Genel Özellikleri</b>	<i>General Specifications of E Series Gearboxes</i>	Allgemeine Eigenschaften von E Serie Getrieben	04
	<b>Teknik Tanımlamalar</b>	<i>Technical Explanations</i>	Technische Erläuterungen	06
	<b>Teknik Özellikler</b>	<i>Technical Specifications</i>	Technische Informationen	07
	<b>Aksesuarlar</b>	<i>Accessories</i>	Zubehör	07
	<b>Yüzey Koruması</b>	<i>Surface Protection</i>	Oberflächenschutz	08
	<b>Tip Tanımlaması</b>	<i>Unit Designation</i>	Typenbezeichnungen	08
	<b>Örnek Tip Tanımlamaları</b>	<i>Sample Designations</i>	Typenbezeichnungsbeispiele	10
	<b>Redüktör Çıkış Özelliği</b>	<i>Gearbox Output Specification</i>	Eigenschaft des Ausgangs	14
	<b>Moment kolu Pozisyonları</b>	<i>Torque Arm Positions</i>	Stelle von Drehmomentstütze	15
	<b>Redüktör Dönüş Yönleri</b>	<i>Direction of Rotation</i>	Getriebedrehrichtungen	16
	<b>Motor Büyüklüğüne Göre Geometrik Mümkün Çevrim Oranı Kombinasyonları</b>	<i>Geomet. Possible Combinations of Ratios According to Motor Size</i>	Geomet. Mögliche Kombi. von Übersetz. nach Motorbaugröße	17
	<b>Servis Faktörü</b>	<i>Service Factor</i>	Betriebsfaktor	18
	<b>Yük Sınıflandırması</b>	<i>Load Classification</i>	Belastungsart	19
	<b>Radyal Yükler</b>	<i>Overhung Loads</i>	Querkräfte	20
	<b>Radyal Yüklerin Hesabı</b>	<i>Calculation Of Overhung Loads</i>	Berechnung der Querkräfte	22
	<b>Sonsuz Vidalarda Termik Güç</b>	<i>Thermal Power for Worm Gearboxes</i>	Thermische Leistung für Schneckenradgetriebe	23
	<b>Verim</b>	<i>Efficiency</i>	Wirkungsgrad	24
	<b>Sonsuz Vidada Otoblokajlık</b>	<i>Irreversibility by Wormgears</i>	Schneckengetrieb Selbsthemmung	25
	<b>Eşdeğer Güç Hesabı</b>	<i>Equivalent Power Calculation</i>	Äquivalente Leistung	26
	<b>Eşdeğer Güç Hesabı Örneği</b>	<i>Equivalent Power Cal. Example</i>	Beispiel für äquivalente Leistung	27
	<b>Redüktör Seçimi</b>	<i>Gearbox Selection</i>	Getriebeauswahl	28
	<b>Redüktör Seçim Formu</b>	<i>Gearbox Selection Form</i>	Formular für Getriebeauswahl	29
	<b>Yağlama</b>	<i>Lubrication</i>	Schmierung	31
	<b>Yağ Tipleri</b>	<i>Oil Types</i>	Schmierstoffe	34
E0302-0917	<b>Montaj Pozisyonları</b>	<i>Mounting Positions</i>	Bauformen	35
	<b>Yağ Miktarları</b>	<i>Oil Quantities</i>	Ölmengentabelle	36
				37

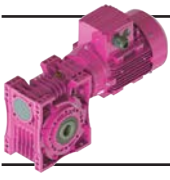

# İçindekiler

## Index

### Inhaltsverzeichnis



<b>Motorlar</b> <i>Motors</i> Motoren	<b>AC Motorlar</b>	<i>AC Motors</i>	Drehstrommotoren	38
	<b>a- Genel Özellikler</b>	<i>a- General Spec. of AC Motors</i>	a- Eigensch. des Drehstrommotors	38
	<b>b- Çalışma Türleri</b>	<i>b-Modes of Operation</i>	b- Betriebsarten	39
	<b>c- Koruma Sınıfı</b>	<i>c- Protection Class</i>	c- Schutzarten	40
	<b>d- İzolasyon Sınıfı</b>	<i>d- Insulation Class</i>	d- Isolationsklasse	40
	<b>e- Verim Sınıfları</b>	<i>e- Efficiency Classes</i>	e- Energieeffizienzklassen	40
	<b>f- AC Frekans İvertörler</b>	<i>f- AC Frequency Inverters</i>	f- AC Frequenz Umrichter	41
	<b>DC Motorlar</b>	<i>DC Motors</i>	DC Motoren	42
	<b>a- Genel Özellikler</b>	<i>a- General Specif. of DC Motors</i>	a- Eigenschaften von DC Motoren	42
	<b>b- DC Motorların Çalışma İlkeleri</b>	<i>b- Operating principals of DC Motors</i>	b- Funktionsprinzip der DC Motoren	42
	<b>c- DC Motor Çeşitleri</b>	<i>c- Types of DC Motors</i>	c- Arten von DC Motoren	42
	<b>d- DC Motorlarda Hız Kontr.</b>	<i>d- Speed Control of DC motors</i>	d- Drehzahlkontrolle DC Motoren	42
<b>Frenler</b> <i>Brakes</i> Bremsen	<b>Elektromanyetik Frenler</b>	<i>Electromagnetic Brakes</i>	Elektromagnetische Bremsen	43
<b>Güç Devir Tabl.</b> <i>Perform. Tables</i> Leistung- und Drehzahl-Tabellen.	<b>Motorlu Güç Devir Tabloları</b>	<i>Geared Motors Performance Tables</i>	Getriebemotoren Leistung- und Drehzahlübersicht	47
	<b>Motorsuz Güç Devir Tabloları</b>	<i>Gear Units Performance Tables</i>	Getriebe Leistung- und Drehzahlübersicht	159
<b>Ölçü Sayfaları</b> <i>Dimension Pages</i> Abmesungstabellen	<b>EV Serileri</b>	<i>EV Series</i>	EV Serie	68
	<b>EN Serileri</b>	<i>EN Series</i>	EN Serie	126
	<b>ET Serileri</b>	<i>ET Series</i>	ET Serie	177
<b>Mil ve Kovan Ölçüleri</b> <i>Shaft and Hollow Shaft Dimensions</i> Wellen- und Gehäusemaße	<b>Mil Flanş Ağırlıkları</b>	<i>Shaft and Flange Weights</i>	Wellen- und Flanschgewichte	223
	<b>Moment Kolu</b>	<i>Torque Arm</i>	Drehmomentstütze	224
	<b>E Serisi Kovan Ölçüleri</b>	<i>E Series Hollow Shaft Dimensions</i>	Gehäuseabmessungen von E Serie Getrieben	225
	<b>Tavsiye edilen müşteri mil montaj demontaj şekli ve aksesuarları</b>	<i>Advised Customer Shaft Dimensions and Accessories</i>	Empfohlene Wellenmaßen und Verbindungselemente bei Montage	226
	<b>Mil Muhafaza Kapağı</b>	<i>Shaft Protection Cover</i>	Wellenabdeckkappe	227
	<b>Opsiyonel Flanş Ölçüleri</b>	<i>Alternative Flange Dimensions</i>	Sonderflanschmaßen	228

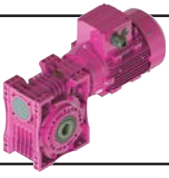

# Genel Bilgiler

## General Information

### Einführung



#### Sembollerin Açıklaması

$c_t$ .....: Anahtarın devreye girme zamanı katsayısı

$f_s$ .....: Servis faktörü

$F_{ama}$ .....: Çıkış milinde müsaade edilen eksenel yükler [kN]

$F_{ame}$ .....: Giriş milinde müsaade edilen eksenel yükler [kN]

$F_{qam}$ .....: Çıkış milinde izin verilen radyal yöndeki yükler [N]

$F_{qem}$ .....: Giriş milinde izin verilen radyal yöndeki yükler [N]

$F_{qa}$ .....: Çıkış miline gelen radyal yöndeki yükler [N]

$F_{qe}$ .....: Giriş miline gelen radyal yöndeki yükler [N]

$F_q$ .....: Çıkış miline gelen radyal yöndeki yükler [N]

$F_a$ .....: Çıkış miline gelen eksenel yöndeki yükler [N]

$i$ .....: Tahvil oranı

$J_{ext}$ .....: Motor miline indirgenmiş toplam dış atalet momenti [kgm<sup>2</sup>]

$M_2$ .....: Çıkış momenti [Nm]

$M_a$ .....: Anma momenti [Nm]

$n_1$ .....: Redüktör giriş mili devri [d/dak]

$n_2$ .....: Redüktör çıkış mili devri [d/dak]

$P_{eq}$ .....: Eşdeğer güç [kW]

$P_e$ .....: Nominal güç (Bak. Güç-Devir Tabloları) [kW]

$P_M$ .....: Tahrik edilecek makina için gerekli güç (Değişken yükler için eşdeğer güç alınır) [kW]

$t$ .....: Zaman [s]

$T_e$ .....: Eşdeğer moment [Nm]

$P_{N2}$ .....: Çıkış gücü [kW]

$P_{N1}$ .....: Giriş gücü [kW]

#### Key of Symbols

$c_t$ .....: Coefficient of switch on time.

$f_s$ .....: Service factor

$F_{ama}$ .....: Permissible axial loads which can be applied to output shaft. [kN]

$F_{ame}$ .....: Permissible axial loads which can be applied to input shaft. [kN]

$F_{qam}$ .....: Permissible overhung loads which can be applied to output shaft. [N]

$F_{qem}$ .....: Permissible overhung loads which can be applied to input shaft. [N]

$F_{qa}$ .....: Overhung loads applied to the output shaft [N]

$F_{qe}$ .....: Overhung loads applied to the input shaft. [N]

$F_q$ .....: Overhung loads on output shaft [N]

$F_a$ .....: Axial loads on output shaft [N]

$i$ .....: Transmission ratio

$J_{ext}$ .....: The total inertia of rotating parts at outside reduced at the motor shaft [kgm<sup>2</sup>]

$M_2$ .....: Output torque [Nm]

$M_a$ .....: Nominal torque [Nm]

$n_1$ .....: Input speed of gearbox [rpm]

$n_2$ .....: Output speed of gearbox [rpm]

$P_{eq}$ .....: Equivalent power [kW]

$P_e$ .....: Nominal power (given on performance tables) [kW]

$P_M$ .....: Required power for the driven machine (for alternating power, refer to equivalent power) [kW]

$t$ .....: Time [s]

$T_e$ .....: Equivalent torque [Nm]

$P_{N2}$ .....: Output Power [kW]

$P_{N1}$ .....: Input Power [kW]

#### Erklärung der Bezeichnungen

$c_t$ .....: Koeffizient der Tätigkeitszeit von Schalter

$f_s$ .....: Betriebsfaktor

$F_{ama}$ .....: Zulässige Axialkräfte auf Abtriebswelle [kN]

$F_{ame}$ .....: Zulässige Axialkräfte auf Antriebswelle [kN]

$F_{qam}$ .....: Zulässige Querkräfte auf Abtriebswelle [N]

$F_{qem}$ .....: Zulässige Querkräfte auf Antriebswelle [N]

$F_{qa}$ .....: Querkräfte auf Abtriebswelle [N]

$F_{qe}$ .....: Querkräfte auf Antriebswelle [N]

$F_q$ .....: Querkräfte auf Abtriebswelle [N]

$F_a$ .....: Querkräfte auf Antriebswelle [N]

$i$ .....: Übersetzungsverhältnis

$J_{ext}$ .....: Die Gesamtträgheit der rotierende Teile von der Ausgangsseite reduziert auf Motorwelle [kgm<sup>2</sup>]

$M_2$ .....: Ausgangsdrehmoment [Nm]

$M_a$ .....: Nenndrehmoment [Nm]

$n_1$ .....: Antriebsdrehzahl [U/min]

$n_2$ .....: Abtriebsdrehzahl [U/min]

$P_{eq}$ .....: Äquivalente Leistung [kW]

$P_e$ .....: Getriebe Nennleistung (siehe Leistung- Drehzahl tabellen) [kW]

$P_M$ .....: Leistung benötigt an der Abtriebswelle (Zur Berechnung bei variablen Leistungen äquivalente Leistung benutzen) [kW]

$t$ .....: Zeit [s]

$T_e$ .....: Minimales Drehmoment [Nm]

$P_{N2}$ .....: Ausgangsleistung [kW]

$P_{N1}$ .....: Eingangsleistung [kW]

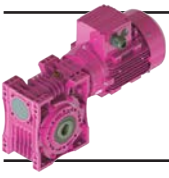

# Genel Bilgiler

## General Information

### Einführung



#### Ürün Yelpazesi

Elinizdeki katalog sadece **E serisi** ürünleri içermektedir.

##### - M ve N Serisi

Helisel alın dişliye sahip, giriş ve çıkış milleri aynı düzlem üzerinde ve birbirine paralel uzanan, üzerlerinde bulunan ayak veya flanş ile makina-ya sabitlenen redüktörlerdir. Dolu mil çıkışlıdır.

##### - D Serisi

Helisel alın dişliye sahip, giriş ve çıkış milleri aynı düzlem üzerinde, birbirine paralel ve belirli bir aralıkta yerleştirilmiş, iki yan yüzde bulunan bağlantı civataları, flanş veya tork kolu ile makina-ya sabitlenen redüktörlerdir. Delik milli veya mil çıkışlı olabilir.

##### - E Serisi

Sonsuz vida ve çark dişlili, belirli bir aralıkta ve birbirine dik konumlandırılmış giriş ve çıkış millerine sahip, çepçevre konumlandırılmış ayak bağlantıları, flanş veya tork kolu ile makina-ya sabitlenen redüktörlerdir. Delik milli veya mil çıkışlı olabilir.

##### - Y Serisi

Yatık tip redüktörler, ağır şartlarda çalışmak üzere dizayn edilmiş redüktör tipleridir. Bu tiplerde redüktör ile bunu tahrik eden mekanizma arasında değişik bağlantı şekilleri mevcuttur (Mekanik ve hidrolik kaplinler, çeşitli tip kayışlar ve zincirle tahrik gibi). Delik milli veya mil çıkışlı olabilir.

##### - K Serisi

Helisel alın dişli ve konik dişlilerden oluşan, birbirine dik ve belirli bir aralıkta konumlandırılmış giriş ve çıkış milline sahip, çepçevre sunulan ayaklar, flanş veya tork kolu ile makina-ya sabitlenen redüktörlerdir. E serisinden farklı olarak yüksek verime sahiptirler. Delik milli veya mil çıkışlı olabilir.

##### - H ve B Serisi

Helisel ve/veya konik dişliye sahip ağır hizmet tipi redüktörlerdir. Giriş ve çıkış milleri birbirine paralel veya dik olabilir. Her yönden bağlantı için ayak bağlantıları bulunur. Opsiyonel olarak flanş ile de bağlanabilir. Delik milli veya mil çıkışlı olabilir.

##### - T Serisi

T Serisi redüktörler helisel dişli iki kademe motorsuz delik milli redüktörlerdir. T Serisi redüktörler delik milli olması ve kompakt gövde yapısı sayesinde daha küçük hacimli alanlara montajı yapılabilmektedir.

##### - P ve R Serisi

P ve R Serisi redüktörler planet dişli redüktörlerdir. Endüstriyel ve mobil uygulamalarda kullanılırlar. Diğer redüktör tiplerine göre daha küçük hacimde daha büyük tork iletebilirler.

##### - V Serisi

V vinç redüktörleri M1 - M8 (1Dm - 5m) vinç sınıflarına uygun olarak, çift veya sabit devirli frenli motorlarla üretilebilmektedir.

#### Production Range

*This catalogue is containing E serie of gearboxes only.*

##### - M and N Series

*M and N series of YILMAZ REDÜKTÖR are helical geared. The input and output shafts are parallel to each other and on the same plane. The gearbox can be connected to the machine by using the foot or flange on the gearbox. Has solid output shaft.*

##### - D Series

*D series are helical geared gearboxes with parallel input and output shafts. The shafts have a distance in between and located on the same plane. The gearbox can be assembled to the machine by using, the connection screws on the sides, flange or torque arm on the gearbox. Can have hollow or solid output shaft.*

##### - E Series

*E series gearboxes are with worm and worm-wheel. The input and output shafts are perpendicular to each other and have a distance in between. It can be assembled to the driven machine by the use of the foot, flange or torque arm on the gearbox. Can have hollow or solid output shaft.*

##### - Y Series

*Horizontal type gearboxes are designed to operate in heavy conditions. In these types there are a lot of combination forms between gearbox and driver (for example, mechanic and hydraulic couplings, various belt and chain drives etc.). Can have hollow or solid output shaft.*

##### - K Series

*These are gearboxes with helical and bevel gears. The input and output shafts are perpendicular to each other and have a distance in between. It can be assembled to the driven machine using the foot, flange or torque arm on the gearbox. They have high efficiency compared to E series. Can have hollow or solid output shaft.*

##### - H and B Series

*These gearboxes are helical or/and bevel geared industrial gearboxes. The input and output shafts can be arranged parallel or perpendicular to each other. The gearbox can be assembled by the use of the foot connections on each side. Flange connections are optional. Can have hollow or solid output shaft.*

##### - T Series

*T Series are gear units which are helical geared, two staged, hollow shaft mounted gear units and manufactured according to monoblock principal. T Series gearboxes have hollow shaft and compact housing so that T series can be mounted on smaller places.*

##### - P and R Series

*P and R Series gearboxes are planetary gearboxes. They are mostly used by industrial and mobile applications. Planetary gearboxes can transfer high torques in small volumes compared to other gearboxes.*

##### - V Series

*V hoist drives are produced according to M1 - M8 (1Dm - 5m) crane classes.*

#### Produktpalette

Dieses Katalog umfasst nur die **E Serie** Getriebe.

##### - M und N Serie

Diese Modelle sind Stirnradgetriebe mit parallelen Antriebs- und Abtriebswelle auf einer Ebene. Die Getriebe werden mit Fuß- oder Flanschverbindung an die angetriebene Maschine angekoppelt. Hat Vollwelle am Ausgang.

##### - D Serie

Diese Getriebe sind Stirnradgetriebe mit paralleler Antriebs- und Abtriebswelle, die auf einer Ebene liegen und einen Abstand zueinander haben. Diese Getriebe wird seitlich mit Gewindelöchern am Maschine oder mit einer Flansch verbindet. Kann Voll- und Hohlwelle am Ausgang haben.

##### - E Serie

Diese Getriebe bestehen aus Schnecke und Schneckenrad. Die Antriebs- und Abtriebswellen sind senkrecht zueinander und haben einen bestimmten Abstand. Das Getriebe wird mit Fußbefestigung, Flanschverbindung oder mit Drehmomentstütze an die angetriebene Maschine montiert. Kann Voll- und Hohlwelle am Ausgang haben.

##### - Y Serie

Diese Getrieben sind für Einsatz unter schweren Bedingungen ausgelegt. Bei dieser Ausführung gibt es sehr viele verschiedene Verbindungsmöglichkeiten zwischen Antrieb und Getriebe (Zum Beispiel; mechanische und hydraulische Kupplungen, Riemtrieb, Kettentrieb usw.). Kann Voll- und Hohlwelle am Ausgang haben.

##### - K Serie

Diese Getrieben bestehen aus Stirnräder und Kegelhäder. Die Antrieb und Abtriebswellen sind senkrecht und haben einen Abstand zueinander. Das Getriebe wird mit Fußbefestigung, Flanschverbindung oder Drehmomentstütze an die angetriebene Maschine montiert. Der Wirkungsgrad ist wesentlich höher als E Serie. Kann Voll- und Hohlwelle am Ausgang haben.

##### - H und B Serie

Diese Getriebe sind geeignet für industrielle Anwendungen und haben parallelen oder senkrechten Antrieb und Abtriebswelle auf einer Ebene. Das Getriebe kann mit Füßen, die auf jede Seite der Getriebe vorhanden sind, oder optional mit Flansch an die angetriebene Maschine montiert werden. Kann Voll- und Hohlwelle am Ausgang haben.

##### - T Serie

T Serien Getriebe sind zwei stufige, schrägverzahnte Hohlwellenflachgetriebe in Monoblockgehäuse. Die T Serie hat eine kompakte Gehäuse und ist serienmäßig mit Abgangshohlwelle hergestellt, so dass das Getriebe minimalen Platzbedarf hat.

##### - P und R Serie

P und R Serie sind Planetengetriebe, die vielseitig im Industrie und bei mobiler Anwendungen einsetzbar sind, mit Planetenzahnräder. Planetengetriebe können im Vergleich zu anderen Getriebe größere Drehmomente bei kleineren Bauvolumen übertragen.

##### - V Serie

V Krane und Hebezeuge werden geeignet zur Kranklasse M1 - M8 (1Dm - 5m) hergestellt.

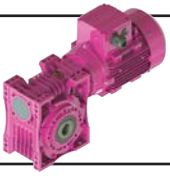

# Genel Bilgiler

## General Information

### Einführung



M ...

**13 farklı büyüklükte;**  
**Moment aralığı: 50 - 18.000 Nm**  
**Devir aralığı: 0,1 - 500 d/dak**  
13 different sizes:  
Torque range: 50 - 18.000 Nm  
Speed range: 0,1 - 500 rpm  
13 verschiedene Baugrößen:  
Drehmomentbereich: 50 - 18.000 Nm  
Drehzahlbereich : 0,1 - 500 U/min



N ...

**13 farklı büyüklükte;**  
**Moment aralığı: 50 - 18.000 Nm**  
**Devir aralığı: 0,1 - 500 d/dak**  
13 different sizes:  
Torque range: 50 - 18.000 Nm  
Speed range: 0,1 - 500 rpm  
13 verschiedene Baugrößen:  
Drehmomentbereich: 50 - 18.000 Nm  
Drehzahlbereich : 0,1 - 500 U/min



E ...

**8 farklı büyüklükte;**  
**Moment aralığı: 5 - 1.000 Nm**  
**Devir aralığı: 0,1 - 400 d/dak**  
8 different sizes:  
Torque range: 5 - 1.000 Nm  
Speed range: 0,1 - 400 rpm  
8 verschiedene Baugrößen:  
Drehmomentbereich: 5-1.000 Nm  
Drehzahlbereich : 0,1-400 U/min



K ...

**11 farklı büyüklükte;**  
**Moment aralığı: 200 - 15.000 Nm**  
**Devir aralığı: 0,1 - 400 d/dak**  
11 different sizes:  
Torque range: 200 - 15.000 Nm  
Speed range: 0,1 - 400 rpm  
11 verschiedene Baugrößen:  
Drehmomentbereich: 200 - 15.000 Nm  
Drehzahlbereich : 0,1 - 400 U/min



D...

**10 farklı büyüklükte;**  
**Moment aralığı: 130 - 18.000 Nm**  
**Devir aralığı: 0,1 - 350 d/dak**  
10 different sizes:  
Torque range: 130 - 18.000 Nm  
Speed range: 0,1 - 350 rpm  
10 verschiedene Baugrößen:  
Drehmomentbereich: 130 - 18.000 Nm  
Drehzahlbereich : 0,1 - 350 U/min



Y ...

**25 farklı büyüklükte;**  
**Moment aralığı: 1200 - 43000 Nm**  
**Devir aralığı: 2,6 - 990 d/dak**  
25 different sizes:  
Torque range: 1200 - 43000 Nm  
Speed range: 2,6 - 990 rpm  
25 verschiedene Baugrößen:  
Drehmomentber. :1200-43000 Nm  
Drehzahlbereich : 2,6-990 U/min

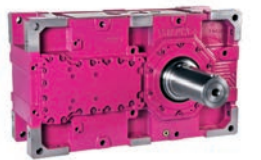

H ...

**13 farklı büyüklükte;**  
**Moment aralığı: 2.500 - 150.000 Nm**  
**Devir aralığı: 0,1 - 250 d/dak**  
13 different sizes:  
Torque range: 2.500 - 150.000 Nm  
Speed range: 0,1 - 250 rpm  
13 verschiedene Baugrößen:  
Drehmomentber. :2.500 - 150.000 Nm  
Drehzahlbereich : 0,1 - 250 U/min

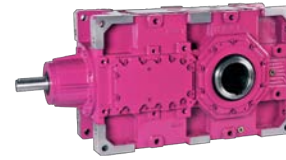

B ...

**13 farklı büyüklükte;**  
**Moment aralığı: 5.000 - 150.000 Nm**  
**Devir aralığı: 0,1 - 115 d/dak**  
13 different sizes:  
Torque range: 5.000 - 150.000 Nm  
Speed range: 0,1 - 115 rpm  
13 verschiedene Baugrößen:  
Drehmomentber. :5.000-150.000 Nm  
Drehzahlbereich : 0,1-115 U/min



P ...

**10 farklı büyüklükte;**  
**Moment aralığı: 1.000 - 50.000 Nm**  
**Tahvil oranları: 3,5 - 3000 arası**  
10 different sizes:  
Torque range: 1.000 - 50.000 Nm  
Transmission ratio: 3,5 - 3000  
10 verschiedene Baugrößen:  
Drehmomentber. : 1.000 - 50.000 Nm  
Übersetzung: 3,5 - 3000



R ...

**10 farklı büyüklükte;**  
**Moment aralığı: 1.000 - 50.000 Nm**  
**Tahvil oranları: 3,5 - 3000 arası**  
10 different sizes:  
Torque range: 1.000 - 50.000 Nm  
Transmission ratio: 3,5 - 3000  
10 verschiedene Baugrößen:  
Drehmomentber. : 1.000 - 50.000 Nm  
Übersetzung: 3,5 - 3000



T ...

**10 farklı büyüklükte;**  
**Moment aralığı: 200 - 18.000 Nm**  
**Devir aralığı: 46 - 280 d/dak**  
10 different sizes:  
Torque range: 200-18.000 Nm  
Speed range: 46-280 rpm  
10 verschiedene Baugrößen:  
Drehmomentber. :200-18.000 Nm  
Drehzahlbereich : 46-280 U/min



V ...

**5 farklı büyüklükte;**  
**M1 - M8 ,(1Dm - 5m) vinç sınıfları**  
**ISO 4301 / 1 ,(FEM 9.511/86)**  
5 different sizes  
M1 - M8 ,(1Dm - 5m) crane classes  
ISO 4301 / 1 ,(FEM 9.511 / 86)  
5 verschiedene Baugrößen  
M1 - M8 ,(1Dm - 5m) Kranklasse  
ISO 4301 / 1 ,(FEM 9.511 / 86)

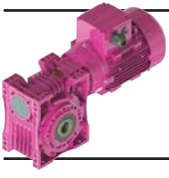

# Genel Bilgiler

## General Information

### Einführung



#### E Serisi Redüktörlerin Genel Özellikleri

E Serisi redüktörler, sonsuz vida ve dişli yapısında oluşan redüktörlerdir. Giriş ve çıkış milleri 90° olması gereken durumlarda kullanılır. Sertleştirilmiş ve taşlanmış vida (21NiCrMo2), fosfor bronzlu çark (Gz12SnCuNi) yüksek mukavemet ve verim sağlamaktadır.

E Serisi redüktörler her yandan bağlanabilen değişebilir gövde sistemi ile montaj kolaylığı ve esnekliği getirmektedir. Flanş ve çıkış mil bağlantıları çok alternatifli montajlar için uygundur.

E30-E80 Alüminyum enjeksiyon döküm, E100-E125 pik döküm gövde malzemesi kullanılmıştır.

YILMAZ REDÜKTÖR olarak tasarım prensibimiz;

- Yüksek teknoloji kullanmak
- Güvenilirlik,
- Yüksek güç yoğunluğu,
- Yüksek verim,
- Montaj uyumluluğu,
- Esnek çözümler

#### Dikkat Edilecek Hususlar !

- Bu katalogta verilen resimler görsel amaçlıdır ve şekilsel detaylar bağlayıcı değildir.

- YILMAZ REDÜKTÖR, ürünler ve kataloglar üzerinde, müşterileri bilgilendirmeksizin her türlü değişikliği yapma hakkına sahiptir.

- Ürünler teslim alındıktan sonra ürünle birlikte verilen kullanım kılavuzu okunmadan sistem devreye alınmamalıdır.

- Katalogta verilen yağ miktarları referans amaçlıdır. Gerçek yağ seviyesi için redüktör üzerinde bulunan yağ seviye tapası kullanılmalıdır. Yağ viskozitesi için, redüktör etiketine bakınız.

- Sipariş anında montaj pozisyonu bildirilmeyen redüktörler **M1** montajına uygun sevk edilir. Etiketle yazan montaj pozisyonundan farklı bağlanan redüktörler garanti kapsamından çıkar. Bu katalogta verilen redüktör ağırlıkları ortalama ağırlık değerleridir. Tahvil oranına ve üzerinde bağlı olan aksesuara göre ağırlıklar farklılık gösterebilir.

#### General Specifications of E Series Gearboxes

*E Series gearboxes are worm geared gearboxes. Input and output shafts are perpendicular to each other. Hardened and grounded cylindrical worm (21NiCrMo2) and phosphorus bronze worm wheel (Gz12SnCuNi) gives maximum strength and maximum efficiency.*

*With alternative mounting position from all sides provided easy and flexible assembly condition. Flange and output shaft connections are convenient for wide range of mounting.*

*From E030 to E080 gearbox housings are made of Aluminium injection casting, E100 and E125 sizes are made of iron casting housings.*

*As we are YILMAZ REDÜKTÖR, our design principals are;*

- Using high technology
- Reliability
- High power density
- High efficiency
- Mounting compatible
- Flexible solutions

#### Attention to the following points !

*- Drawings are examples only and the details on the drawings or illustrations are not strictly binding.*

*- YILMAZ REDÜKTÖR reserve the right to make all kinds of changes in products and catalogues without any notice.*

*- Prior to commissioning, the operating instructions provided with the gearbox must be observed.*

*- Oil quantities given are guide values only. The exact quantity of oil should be checked by using the provided oil level plugs according mounting positions. For correct oil viscosity refer to the nameplate.*

*- If the mounting position is not informed upon ordering, the gear unit is delivered according to **M1** mounting position. If the mounting position is different than the indicated mounting position on the nameplate The product warranty cancels. The weights given in this catalogue are mean values. Depending on the ratio and accessories the weights can differ.*

#### Allgemeine Eigenschaften von E Serie Getrieben

E Serie Getriebe sind Schneckenradgetriebe. Eingang- und Ausgangswelle sind senkrecht zueinander. Gehärtete und geschliffene Zylinderschnecke (21NiCrMo2) und Schneckenrad (Gz12SnCuNi) aus Bronze gibt maximale Stabilität und beste Effizienz.

Die verschiedene Möglichkeiten zur Befestigung von allen Seiten stellt einfache und flexible Montage zur Verfügung. Flansch und Anschlüsse von Abtriebswelle sind bequem für eine Vielzahl von Montage.

E30-E80 Baugrößen sind aus Aluminium mit Spritzgussverfahren gefertigt und E100-E125 Baugrößen haben aus Eisenguss gefertigte Gehäusen.

Als YILMAZ REDÜKTÖR unsere Entwurfsprinzipien sind;

- Verwenden von hohen Fertigungstechnik
- Hohe Betriebssicherheit
- Leistungsdichte
- Hoher Wirkungsgrad
- Universale Montagemöglichkeit
- Sonderlösungen

#### Bitte folgende Punkte beachten !

- Die Abbildungen sind beispielhaft und nicht verbindlich.

- Alle Änderungen auf dem Katalog und an den Produkte bleiben vorbehalten und können ohne Kenntnisnahme erfolgen.

- Vor Inbetriebnahme ist die mit gelieferter Betriebsanleitung zu beachten.

-Angaben über Ölmengen sind unverbindlich. Maßgebend ist die Ölstandsschraube in der geeigneten Montageposition. Ölviskosität und Sorte muss den Angaben des Typenschildes entsprechen.

- Wenn die Bauform bei der Bestellung nicht angegeben ist, erfolgt die Lieferung in der Bauform **M1**. Wenn die Getriebe anders als auf dem Typenschild benannte Bauform eingesetzt werden, verliert die Garantie ihre Gültigkeit. Die angegebenen Gewichte sind unverbindliche Mittelwerte ohne Zubehör; genauere Gewichte sind abhängig von Zubehör und Übersetzung.

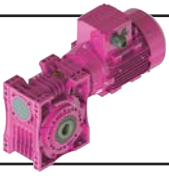

# Genel Bilgiler

## General Information

### Einführung



#### Teknik Tanımlamalar

##### - Çıkış Momenti $M_2$ : [Nm]

Motorun verdiği momentin tahvil oranı ve verimle ile çarpılarak elde edilen değerdir. Redüktörün çıkışından alınabilecek moment gösterir.

##### - Anma Momenti $M_a$ : [Nm]

Redüktörün  $f_s=1$  şartı için mekanik olarak taşıdığı moment değeridir.

##### - Nominal Güç $P_e$ : [kW]

Nominal güç, redüktörün  $f_s=1$  şartı için mekanik olarak taşıyabileceği güç değeridir. Redüktörlerin nominal güçleri, güç devir tablolarında verilmiştir.

##### - Çevrim oranı i:

Redüktörün giriş devrinin çıkış devrine oranıdır. Yılmaz Redüktör E serisi redüktörlerde 3,5-14000 arasında değişen çevrim oranları mevcuttur.

##### - Eşdeğer Güç ve Moment

$P_{eq}$  [kW],  $T_e$  [Nm]

Sabit devir altında ancak değişken yük değerlerinde çalışan redüktörlerde, sabit yük altında çalışma şartlarına eşdeğer gelen moment ve güç değerleridir. Hesaplama yöntemi sayfa 28'de verilmiştir.

##### - İhtiyaç güç $P_M$ : [kW]

Redüktörlerin kullanılacağı uygulamanın istenilen şekilde çalışabilmesi için ihtiyaç duyduğu güç değeridir.

##### - İhtiyaç moment T: [Nm]

Redüktörün kullanılacağı uygulamanın çalışabilmesi için ihtiyaç duyduğu moment değeridir. Seçilen redüktör için her zaman çıkış momentini eşit yada daha düşük olmalıdır.

##### - Müsade Edilen Eksenel ve Radyal Yükler

Fqem, Fqam: [N]

Redüktörün giriş veya çıkış milinde müsade edilen eksenel ve radyal yüklerdir.

##### - Servis Faktörü $f_s$ :

Redüktörün çalıştığı şartlar ile uyumlu olması için gerekli olan emniyet katsayısıdır.  $f_s=1$ , düzgün ve sakin yüklerde, günlük sekiz saat, saatte 100 dur-kalk çalışmayı karşılar. Detaylar için redüktör seçim bölümüne bakınız.

#### Teknik Özellikler:

##### - Ses seviyesi:

Redüktörlerimizin ses seviyesi VDI 2159' da verilen redüktörler için müsade edilen ses seviyelerinin altındadır.

##### - Yağlama:

E serisi redüktörler yağlama tablolarında verilen yağlar ile doldurulmaktadır. Yağ detayları için yağlama bölümüne bakınız.

#### Technical Explanations

##### - Output Torque $M_2$ : [Nm]

Multiplication of motor torque with transmission ratio and efficiency gives the result of output torque on the output shaft of the gear unit.

##### - Nominal Torque $M_a$ : [Nm]

Nominal torque is the mechanical torque which the gearbox can resist under  $f_s=1$  conditions.

##### - Nominal Power $P_e$ : [kW]

The nominal power is the power which gearbox can mechanically resist under  $f_s=1$  condition. The nominal powers are given on the performance tables.

##### - Ratio i:

Ratio between output shaft speed and input shaft speed. Available ratios of Yılmaz Redüktör E series are between 3,5 to 14000.

##### - Equivalent Power and Torque

$P_{eq}$ : [kW],  $T_e$  [Nm]

For gearbox value with constant speed but variable working conditions: This is the calculated power or torque which is equivalent to the values at working under constant working conditions. Calculation methods are given page on pages 28.

##### - Required Power $P_M$ : [kW]

Required power for the applications which is able to drive the system.

##### - Required Torque T: [Nm]

Required torque for applications. Required torque always must be equal or smaller than output torque of selected gearbox.

##### - Permissible Axial and Overhung Loads:

Fqem, Fqam [N]

Permissible axial and overhung load on the output or input shaft of gearboxes.

##### - Service Factor $f_s$ :

Service factor is a safety coefficient, which takes into account the different running conditions of the driven machine.  $f_s=1$  is used for uniform loads 8 hours working per day and up to 100 cycle per hour.

#### Technical Specifications:

##### - Noise Level:

The noise level of our gearboxes is lower than permitted values defined in VDI guidelines 2159 for gear units.

##### - Lubrication:

E series of gearboxes are filled with oils which are indicated on lubrication tables. For lubrication details please refer to the lubrication section.

#### Technische Erläuterungen

##### - Ausgangsmoment $M_2$ : [Nm]

Multiplikation von Ausgangsmoment des Motors mit Übersetzung und Division das Ergebnis mit Wirkungsgrad ergibt den Betrag von Ausgangsmoment der Getriebe.

##### - Nennmoment $M_a$ : [Nm]

Mechanisches Belastungsmoment der Getriebe unter dem Bedingung  $f_s=1$ .

##### - Nennleistung $P_e$ : [kW]

Die Nennleistung ist die mechanische Grenzfestigkeitsleistung für  $f_s=1$ . Kann von der Leistung- Drehzahltable abgelesen werden.

##### - Übersetzung i:

Wird aus dem Verhältnis von Ausgang- zu Eingangswinkelgeschwindigkeit bestimmt. Gängige Übersetzungen von Yılmaz M Serie Getrieben liegen zwischen 3,5 bis 14000.

##### - Äquivalente Leistung und Moment

$P_{eq}$ : [kW],  $T_e$  [Nm]

Für mit konstanten Drehzahl aber unter veränderlichen Betriebsbedingungen arbeitende Getriebe berechnete Leistung und Moment äquivalent zu Werten beim Arbeiten unter konstanten Betriebsbedingungen.

##### - Notwendige Leistung $P_M$ : [kW]

Die für das Getriebe notwendige Leistung, um Arbeiten von Getriebe bei der für das Getriebe gedachten Anwendung zu gewährleisten.

##### - Notwendige Moment T: [Nm]

Notwendige Moment für Anwendungen. Für das ausgewählte Getriebe soll das notwendige Moment gleich dem Ausgangsmoment oder kleiner als diesem Moment sein.

##### - Zulässige Axial- oder Querkräfte:

Fqem, Fqam [N]

Bei den Anwendungen während des Betriebs zulässige axiale oder radiale Eingangs- oder Ausgangsbelastungen.

##### - Betriebsfaktor $f_s$ :

Dieser Faktor  $f_s$  ist ein Sicherheitsfaktor, damit die Getriebe unter verschiedenen Bedingungen mit genügender Sicherheit arbeitet.  $f_s=1$  gilt für gleichförmig Belastung, mit 8 Betriebsstunden pro Tag und bis zum 100 Schaltungen pro Stunde.

#### Technische Informationen:

##### - Geräuschpegel:

Geräuschstärken aller Getriebe bleiben unter die zulässigen Werte, die für die Getriebe in der VDI-Richtlinie 2159 festgelegt sind.

##### - Schmierung:

E Serie Getriebe werden mit Ölen entsprechend der Schmierungstabellen, falls nicht anders vereinbart, geliefert. Für weitere Schmierungsgaben siehe Kapitel Schmierung.

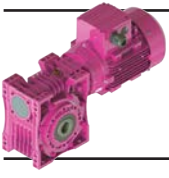

# Genel Bilgiler

## General Information

### Einführung



#### - Aksesuarlar:

E serisi redüktörlerde aşağıdaki aksesuarlar kullanılabilir

- IEC B5 Motor bağlantı flanşları
- Çıkış Bağlantı Flanşları
- Geri dönüş kilidi
- Özel keçe çözümleri,
- Şeffaf yağ seviye göstergesi
- Tork kolu
- Elektromanyetik frenler

Diğer özel aksesuarlar için lütfen, YILMAZ REDÜKTÖR ile temasa geçiniz.

#### - Yüzey Koruması

Redüktörlerimiz aksi belirtilmedikçe boyalı olarak sevk edilmektedir. DIN EN ISO 12944-2 korozyon standardında belirtilen sınıflardan aşağıdaki tabloda belirtilen 4 kategori için yüzey koruması sağlanmaktadır. Standart boya sınıfımız C2 korozyon kategorisini karşılamaktadır. Farklı bir koruma sınıfı istenirse sipariş aşamasında belirtilmelidir.

Mil, flanş bağlantı yüzeyi gibi boyanmayan yüzeylere paslanmaya karşı koruma sağlamak için korozyon önleyici yağ sürülmektedir.

#### - Accessories:

The following accessories can be applied to E series gearboxes.

- IEC B5 Motor connection flange
- Output flanges
- Backstops
- Special sealing solutions.
- Transparent oil level indicator,
- Torque arm
- Electromagnetic brakes.

For other accessories please contact, YILMAZ REDÜKTÖR.

#### - Surface Protection

Our products are all painted unless otherwise stated. 4 corrosion categories which are mentioned below can be offered according to corrosion categories of DIN EN ISO 12944-2 standard. Our standard paint meets C2 corrosion category. If different category is requested, please inform before order.

Unpainted parts such as shaft, flange connection surface are coated with anti-corrosion paint before shipment against corrosion.

#### - Zubehör:

Folgendes Zubehör kann für Getriebe der E Serie geliefert werden.

- IEC B5 Motor Adapter,
- Abtriebsflansch,
- Rücklaufsperrern,
- Unterschiedliche Dichtungssysteme,
- Ölstandzeiger
- Drehmomentstütze
- Elektromagnetische Bremsen

Für weiteres Zubehör kontaktieren Sie bitte mit, YILMAZ REDÜKTÖR.

#### - Oberflächenschutz

Getriebe von Yılmaz Redüktör werden lackiert und so geliefert falls nicht anders vereinbart ist. Die 4 untenstehenden Korrosionskategorien können nach Korrosionsschutz-Basisnorm DIN EN ISO 12944-2 angeboten werden. Unsere Standard-Lackierung erfüllt C2-Korrosionskategorie. Wenn Sie eine andere Kategorie erwünschen, informieren Sie uns bitte darüber vor der Bestellung.

Nicht lackierte Teile (z.B. Welle, Oberfläche des Anschlussflanschs) werden mit einem Schutzmittel vor dem Versand geschmiert, um vor Korrosion und Rost zu schützen.

Korozyon Kategorisi Corrosion Categories Korrosivitätskategorie	Çevre Şartları Ambient Conditions Umgebungsbedingungen	Boya Tipi Paint Type Lackierung	Boya Kalınlıkları Paint Thickness Sollschichtdicke
C2 (Standard)	<b>İç ortam ve muhafazalı dış ortam</b> <b>Nem ve kirlilik oranı düşük çalışma ortamı</b> Indoor installation and outdoor installation with protection roof Environments with low humidity and contamination Innenaufstellung und Außenaufstellung mit Überdachung oder Schutzeinrichtung Atmosphäre mit niedriger Luftfeuchtigkeit und Verunreinigung	<b>Su Bazlı Astar</b> Water Based Primer Coat Wasserbasierte Grundierung <b>Su Bazlı veya Akrilik Sonkat</b> Water Based or Acrylic Top Coat Wasserbasierte oder Akril-Decklack	80 µm 40 µm
C3	<b>İç ortam ve atmosfere açık dış ortam</b> <b>Orta seviyede nem ve kirlilik olan çalışma ortamı</b> Indoor installation and outdoor installation subject to weathering Environments with mean humidity and contamination Innenaufstellung und Außenaufstellung im Freien unter Bewitterung Atmosphäre mit mäßiger Luftfeuchtigkeit und Verunreinigung	<b>Epoksi Astar</b> Epoxy Primer Coat Epoxy-Grundierung <b>Akrilik Sonkat</b> Acrylic Top Coat Akril-Decklack	80 µm 40 µm
C4	<b>İç ortam ve atmosfere açık dış ortam</b> <b>Genelde yüksek nem ve kimyasal madde olan çalışma ortamı</b> Indoor installation and outdoor installation subject to weathering Environments with occasionally high humidity and chemical contamination Innenaufstellung und Außenaufstellung im Freien unter Bewitterung Atmosphäre gelegentlich mit hoher Luftfeuchtigkeit und chemischer Verunreinigung	<b>Epoksi Astar</b> Epoxy Primer Coat Epoxy-Grundierung <b>Akrilik Sonkat</b> Acrylic Top Coat Akril-Decklack	180 µm 40 µm
C5-I / C5-M	<b>İç ortam ve atmosfere açık dış ortam</b> <b>Sürekli yüksek nem ve kimyasal madde ile temizlik yapılan çalışma ortamı</b> Indoor installation and outdoor installation subject to weathering Environments with permanent high humidity and chemical cleaning contamination Innenaufstellung und Außenaufstellung im Freien unter Bewitterung Atmosphäre mit ständiger hoher Luftfeuchtigkeit und chemischer Verunreinigung (Nassreinigung mit Säuren/Laugen und auch mit chemischen Reinigungsmitteln).	<b>Çinko Yükleme Epoksi Astar</b> Epoxy Zinc Primer Coat Epoxy-Zink-Grundierung <b>Epoksi Astar Miox</b> Epoxy Miox Primer Coat Epoxy-Miox-Grundierung <b>Akrilik Sonkat</b> Acrylic Top Coat Akril-Decklack	70 µm 150 µm 40 µm



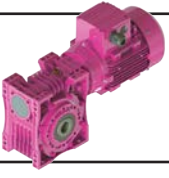

Genel Bilgiler  
General Information  
Einführung



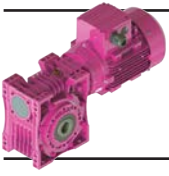

# Genel Bilgiler General Information Einführung



Tip Tanımlaması / Unit Designation / Typenbezeichnung

## E V 063 . 01 - 3 E90S/4C - L05

### Fren / Brake / Bremse

L-220V **Fanlı** / With Fan / Mit Lüfter  
P-24V **Fanlı** / With Fan / Mit Lüfter  
S-220 V **Fansız** / Without Fan / Ohne Lüfter  
Z-24 V **Fansız** / Without Fan / Ohne Lüfter  
**00**-5 Nm **10**-100Nm  
**01**-10 Nm  
**02**-25 Nm  
**04**-40 Nm  
**05**-50 Nm

### Kutup sayısı / Number of Poles / Anzahl der Polen

### Motor Büyüklüğü / Motor Size / Motorbaugröße

#### -EV Tipleri için / For EV types / Für Typen EV

E90S / 4

Kutup Sayısı / Pole Number / Anzahl der Polen

Gövde uzunluğu / Frame Length / Gehäuselänge des Motors

Motor büyüklüğü / Motor size / Motorbaugröße

Motor tipi / Motor type / Motortyp

### Motor Verim Sınıfı / Motor Efficiency Class / Motor-Effizienzklasse

#### -EN tipleri için / For EN Types / Für Typen EN

<b>A05</b> :56 B5	<b>A09</b> :90 B5
<b>B05</b> :56 B14	<b>B09</b> :90 B14
<b>A06</b> :63 B5	<b>A10</b> :100 B5
<b>B06</b> :63 B14	<b>B10</b> :100 B14
<b>A07</b> :71 B5	<b>A11</b> :112 B5
<b>B07</b> :71 B14	<b>B11</b> :112 B14
<b>A08</b> :80 B5	<b>A13</b> :132 B5
<b>B08</b> :80 B14	<b>B13</b> :132 B14

### Çıkış Mili Özelliği / Output Shaft / Eigenschaften der Abtriebswelle

**00** :Standart delik milli / Hollow Output Shaft / Standarte Ausführung mit Hohlwelle

**01** :Mil Çıkışlı / Solid Output Shaft / Vollwelle

**02** :Flanşlı ve mil çıkışlı / Solid Output Shaft and Output Flange / Mit Flansch und Abtriebsvollwelle

**03** :Flanşlı ve delik milli çıkışlı / Output Shaft and Output Flange. / Mit Flansch und Hohltriebsschwelle

**04** :Çift çıkış milli / With Double Output Shaft / Mit doppelter Abtriebswelle

**05** :Çift flanşlı ve çift çıkış milli / With Double Flange and Double Output Shaft / Mit doppeltem Flansch und doppelter Abtriebswelle

**\*06** :Motor karşısından giriş mili çıkışlı / With Shaft Extension from the Opposite Side of the Motor / Mit doppelter verlängerten Abtriebswelle auf der gegenüberliegenden Seite des Motors

**\*\*07** : Motorsuz çift giriş milli / With Double Input Shaft Without Motor / Mit doppelter Antriebswelle

**08** : Çift flanşlı delik milli / With Double Output Shaft and Hollow Output Flange / Doppelte Flansch und Aufsteckenwelle

### Gövde Büyüklük / Housing Size / Größe von Gehäuse

030, 040, 050, 063, 075, 080, 100, 125

### Giriş Tipi / Input Type / Eingangstyp

**N** :Motorsuz ve IEC B5/B14 Flanş girişli / IEC B5 / B14 Input Flange without Motor / Ohne Motor und mit IEC B5/B14 Eingangsflansch

**V** :Motorlu ve IEC B5/B14 Flanş girişli / IEC B5 / B14 Input Flange with Motor / Mit Motor und IEC B5/B14 Eingangsflansch

**T** :Motorsuz / Without Motor Solid Input Shaft / Eingang mit Vollwelle ohne Motor

**\*EN ve EV tiplerinde giriş mili 06 opsiyonel olarak verilmektedir. Gösterim şekli EN050.01-06.A06 vb şeklindedir.**

\*06 code is optional input shaft option for EN and EV types. Description as EN050.01-06.A06.

\*Kode 06 ist auswählbare Eingangswelle für EN und EV Typen. Kann bei EN050.01-06.A06 angesehen werden.

**\*\*ET tiplerinde giriş mili 07 opsiyonel olarak verilmektedir. Gösterim şekli ET050.00-07**

\*07 code is optional input shaft types for ET types. Description as ET050.00-07

\*Kode 07 ist auswählbare Eingangswelle für ET Typen. Kann bei ET050.00-07 angesehen werden.

### Redüktör Tipi / Gearbox Type / Getriebe

E serisi / E serie / E Serie

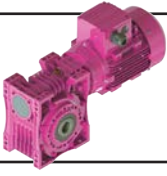

# Genel Bilgiler

## General Information

### Einführung



#### Tip Tanımlaması / Unit Designation / Typenbezeichnung

EN..00..	<b>Sonsuz tip IEC B5/B14 bağlantılı redüktörler, delik milli çıkış / Worm geared units IEC B5/B14 input flange with hollow output shaft / Schneckenradgetriebe mit IEC B5/B14 Eingangsflansch und Hohlwelle am Ausgang</b>
EN..01..	<b>Sonsuz tip IEC B5/B14 bağlantılı redüktörler, mil çıkışlı / Worm geared units IEC B5/B14 input flange, with solid output shaft / Schneckenradgetriebe mit IEC B5/B14 Eingangsflansch und Vollwelle am Ausgang</b>
EN..02..	<b>Sonsuz tip IEC B5/B14 bağlantılı redüktörler, mil ve flanş çıkışlı / Worm geared units IEC B5/B14 input flange, with solid output shaft and output flange / Schneckenradgetriebe mit IEC B5/B14 Eingangsflansch, Vollwelle und Flansch am Ausgang</b>
EN..03..	<b>Sonsuz tip IEC B5/B14 bağlantılı redüktörler, delik milli ve flanş çıkışlı / Worm geared units IEC B5/B14 input flange, with hollow output shaft and output flange / Schneckenradgetriebe mit IEC B5/B14 Eingangsflansch, Hohlwelle und Flansch am Ausgang</b>
EN..04..	<b>Sonsuz tip IEC B5/B14 bağlantılı redüktörler, çift çıkış milli / Worm geared units IEC B5/B14 input flange, with double output shaft / Schneckenradgetriebe mit IEC B5/B14 Eingangsflansch und doppelter Abtriebswelle</b>
EN..05..	<b>Sonsuz tip IEC B5/B14 bağlantılı redüktörler, çift çıkış milli ve çift çıkış flanşlı / Worm geared units IEC B5/B14 input flange, with double output shaft and double output flange / Schneckenradgetriebe mit IEC B5/B14 Eingangsflansch, doppelter Abtriebswelle und doppelter Ausgangsflansch</b>
EN..08..	<b>Sonsuz tip IEC B5/B14 bağlantılı redüktörler, çift flanşlı delik milli / Worm geared units IEC B5/B14 input flange, with double output flange and hollow output shaft / Schneckenradgetriebe mit IEC B5/B14 Eingangsflansch, doppelter Ausgangsflansch und Hohlwelle am Ausgang</b>
EN.....06	<b>Sonsuz tip IEC B5/B14 bağlantılı redüktörler, motor karşısından giriş mili çıkışlı / Worm geared units IEC B5/B14 input flange, shaft extension from the opposite side of the motor / Schneckenradgetriebe mit IEC B5/B14 Eingangsflansch und Verlängerung von Abtriebswelle auf der gegenüberliegenden Seite des Motors</b>

EV..00..	<b>Sonsuz tip motorlu redüktörler, delik milli çıkış / Worm geared motors IEC B5/B14 input flange with motor, hollow output shaft / Schneckenradgetriebemotor mit IEC B5/B14 Eingangsflansch und Hohlwelle am Ausgang</b>
EV..01..	<b>Sonsuz tip motorlu redüktörler, mil çıkışlı / Worm geared motors IEC B5/B14 input flange with motor, solid output shaft / Schneckenradgetriebemotor mit IEC B5/B14 Eingangsflansch und Vollwelle am Ausgang</b>
EV..02..	<b>Sonsuz tip motorlu redüktörler, mil ve flanş çıkışlı / Worm geared motors IEC B5/B14 input flange with motor, solid output shaft and output flange / Schneckenradgetriebemotor mit IEC B5/B14 Eingangsflansch, Vollwelle und Flansch am Ausgang</b>
EV..03..	<b>Sonsuz tip motorlu redüktörler, delik milli ve flanş çıkışlı / Worm geared motors IEC B5/B14 input flange with motor, hollow output shaft and output flange with motor / Schneckenradgetriebemotor mit IEC B5/B14 Eingangsflansch, Hohlwelle und Flansch am Ausgang</b>
EV..04..	<b>Sonsuz tip motorlu redüktörler, çift çıkış milli / Worm geared motors IEC B5/B14 input flange with motor, double output shaft with motor / Schneckenradgetriebemotor mit IEC B5/B14 Eingangsflansch und doppelter Abtriebswelle</b>
EV..05..	<b>Sonsuz tip motorlu redüktörler, çift çıkış milli ve çift çıkış flanşlı / Worm geared motors IEC B5/B14 input flange with motor, double output shaft and double output flange / Schneckenradgetriebemotor mit IEC B5/B14 Eingangsflansch, doppelter Abtriebswelle und doppelter Ausgangsflansch</b>
EV..08..	<b>Sonsuz tip motorlu redüktörler, çift flanşlı delik milli / Worm geared motors IEC B5/B14 input flange with motor, double output flange and hollow output shaft / Schneckenradgetriebemotor mit IEC B5/B14 Eingangsflansch, doppelter Ausgangsflansch und Hohlwelle am Ausgang</b>
EV....-06	<b>Sonsuz tip motorlu redüktörler, motor karşısından giriş mili çıkışlı / Worm geared motors IEC B5/B14 input flange with motor, shaft extension from the opposite side of the motor / Schneckenradgetriebemotor mit IEC B5/B14 Eingangsflansch und Verlängerung von Abtriebswelle auf der gegenüberliegenden Seite des Motors</b>

ET..00..	<b>Sonsuz tip motorsuz redüktörler, delik milli çıkış / Worm geared units solid input shaft, hollow output shaft / Schneckenradgetriebe mit Vollwelle am Eingang und Hohlwelle am Ausgang</b>
ET..01..	<b>Sonsuz tip motorsuz redüktörler, mil çıkışlı / Worm geared units solid input shaft, solid output shaft / Schneckenradgetriebe mit Vollwelle am Eingang und Vollwelle am Ausgang</b>
ET..02..	<b>Sonsuz tip motorsuz redüktörler, mil ve flanş çıkışlı / Worm geared units solid input shaft, solid output shaft and output flange / Schneckenradgetriebe mit Vollwelle am Eingang, Vollwelle und Flansch am Ausgang</b>
ET..03..	<b>Sonsuz tip motorsuz redüktörler, delik milli ve flanş çıkışlı / Worm geared units solid input shaft, hollow output shaft and output flange / Schneckenradgetriebe mit Vollwelle am Eingang, Hohlwelle und Flansch am Ausgang</b>
ET..04..	<b>Sonsuz tip motorsuz redüktörler, çift çıkış milli / Worm geared units solid input shaft, double output shaft / Schneckenradgetriebe mit Vollwelle am Eingang und doppelter Abtriebswelle</b>
ET..05..	<b>Sonsuz tip motorsuz redüktörler, çift çıkış milli ve çift çıkış flanşlı / Worm geared units solid input shaft, double output shaft and double output flange / Schneckenradgetriebe mit Vollwelle am Eingang, doppelter Abtriebswelle und doppelter Ausgangsflansch</b>
ET..08..	<b>Sonsuz tip motorsuz redüktörler, çift flanşlı ve delik mil çıkışlı / Worm geared units solid input shaft, double flange and hollow output shaft / Schneckenradgetriebe mit Vollwelle am Eingang, doppelter Ausgangsflansch und Hohlwelle am Ausgang</b>
ET....-07	<b>Sonsuz tip motorsuz redüktörler, motorsuz çift giriş milli / Worm geared units solid input shaft, double input shaft / Schneckenradgetriebe mit doppelter Vollwelle am Eingang und Verlängerung von Motorwelle an der Seite des Deckels von Motorlüfter</b>

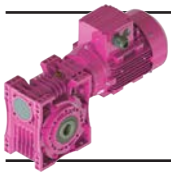

# Genel Bilgiler

## General Information

### Einführung

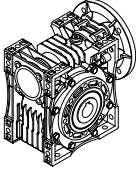
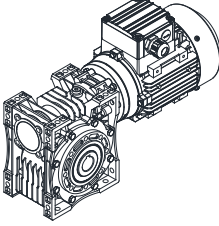
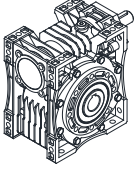
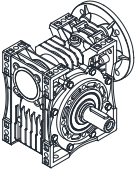
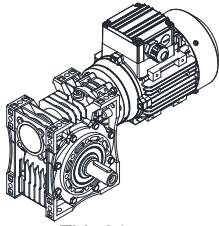
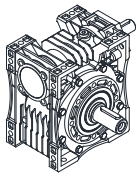
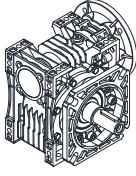
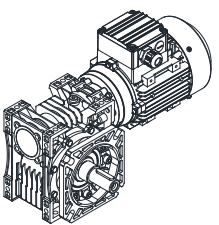
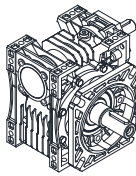
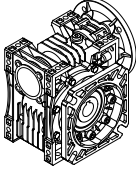
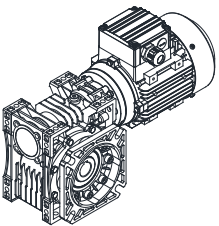
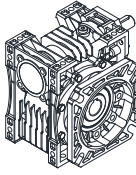
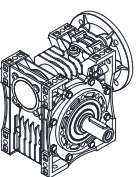
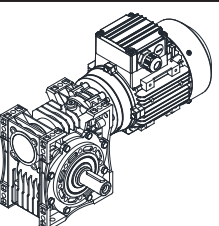
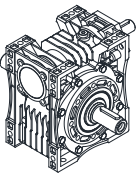
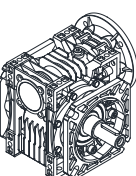
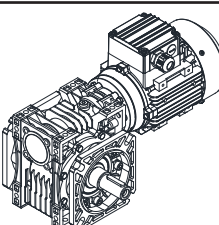
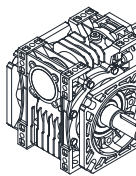
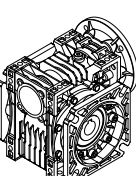
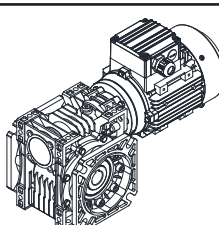
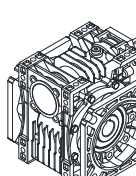

Tip Tanımlaması / Unit Designation / Typenbezeichnungen

 EN...00	 EV...00	 ET...00
 EN...01	 EV...01	 ET...01
 EN...02	 EV...02	 ET...02
 EN...03	 EV...03	 ET...03
 EN...04	 EV...04	 ET...04
 EN...05	 EV...05	 ET...05
 EN...08	 EV...08	 ET...08

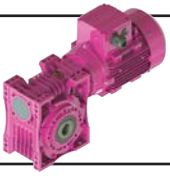

# Genel Bilgiler

## General Information

### Einführung

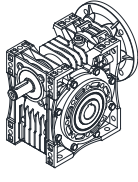
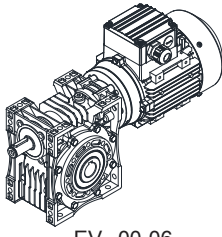
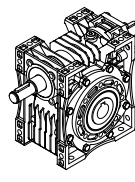
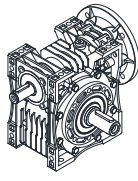
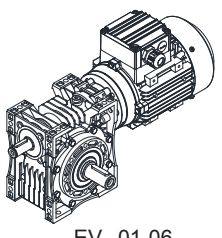
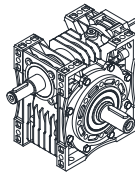
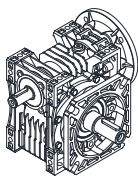
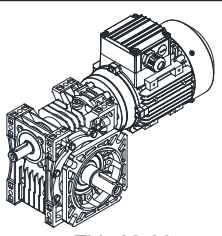
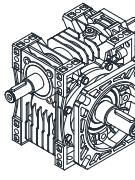
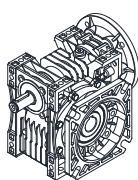
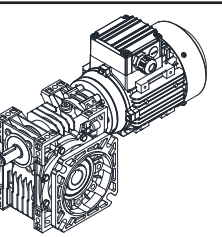
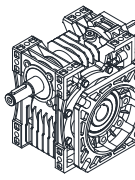
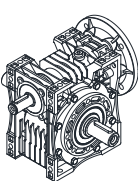
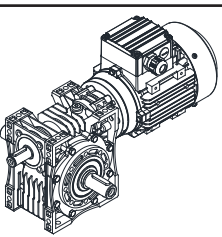
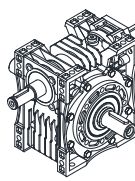
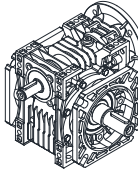
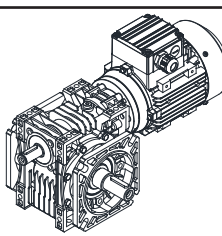
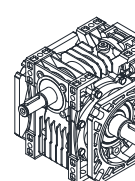
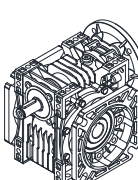
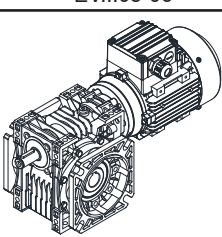
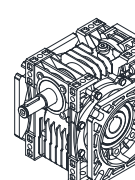

Tip Tanımlaması / Unit Designation / Typenbezeichnungen

 EN...00-06	 EV...00-06	 ET...00-07
 EN...01-06	 EV...01-06	 ET...01-07
 EN...02-06	 EV...02-06	 ET...02-07
 EN...03-06	 EV...03-06	 ET...03-07
 EN...04-06	 EV...04-06	 ET...04-07
 EN...05-06	 EV...05-06	 ET...05-07
 EN...08-06	 EV...08-06	 ET...08-07

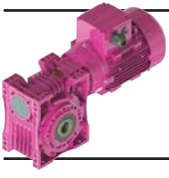

# Genel Bilgiler General Information Einführung



## Örnek Tip Tanımlamaları

EV063.00.3E90S/4C

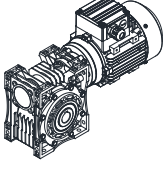

E.....: E serisi redüktör  
V.....: IEC B5/B14 Motor bağlantılı  
063.....: Gövde büyüklüğü  
00.....: Delik mil çıkışı  
3.....: Verim Sınıfı  
E.....: Motor Tipi  
90S.....: Motor büyüklüğü  
4C.....: Motor Kutup Sayısı  
L02.....: Fren Tipi

ET075.01

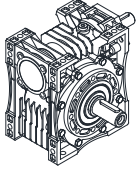

E.....: E serisi redüktör  
T.....: Motorsuz giriş milli  
075.....: Gövde büyüklüğü  
01.....: Mil çıkışı

EN075.03 - A11

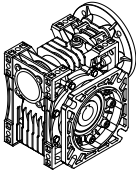

E.....: E serisi redüktör  
N.....: Motorsuz ve IEC B5/B14 giriş flanşlı  
075.....: Gövde büyüklüğü  
03.....: Delik milli flanş bağlantılı çıkış  
A11.....: 112 tip motor, B5/B14 bağlantı flanş

ET063.01-07

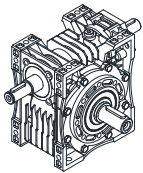

E.....: E serisi redüktör  
T.....: Motorsuz giriş flanşlı  
063.....: Gövde büyüklüğü  
01.....: Delik milli flanş bağlantılı çıkış  
07.....: Çift giriş milli

## Sample Designations

EV063.00.3E90S/4C

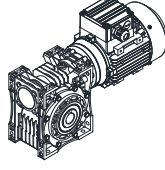

E.....: E series gearbox  
V.....: IEC B5/B14 Motor Connection  
063.....: Gear Unit Size  
00.....: Hollow Shaft Output  
3.....: Efficiency Class  
E.....: Motor type  
90S.....: Motor frame size  
4C.....: Number of poles  
L02.....: Brake Type

ET075.01

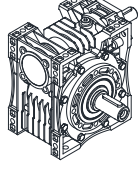

E.....: E series gearbox  
T.....: Solid input shaft  
075.....: Gear unit size  
01.....: Solid output shaft

EN075.03 - A11

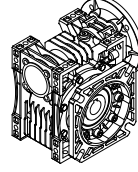

E.....: E series of gearbox  
N.....: IEC B5/B14 flange without motor input  
075.....: Gear unit size  
03.....: Hollow output shaft and output flange  
A11.....: IEC 112 B5/B14 motor connection flange.

ET063.01-07

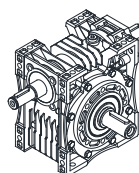

E.....: E series gearbox  
T.....: Solid input shaft  
063.....: Gear unit size  
01.....: Solid output shaft  
07.....: Double input shaft

## Typenbezeichnungsbeispiele

EV063.00.3E90S/4C

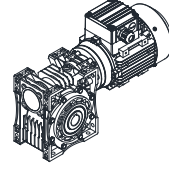

E.....: E serie Getriebe  
V.....: Mit Motor und IEC B5/B14  
Eingangsfansch  
063.....: Größe von Gehäuse  
00.....: Ausführung mit Hohlwelle  
3.....: Effizienzklasse  
E.....: Motortyp  
90S.....: Motorbaugröße  
4C.....: Anzahl der Polen  
L02.....: Bremse

ET075.01

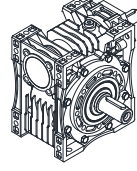

E.....: E serie Getriebe  
T.....: Vollwelleneingang ohne Motor  
075.....: Größe von Gehäuse  
01.....: Vollwelle

EN075.03 - A11

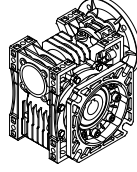

E.....: E serie Getriebe  
N.....: Ohne Motor und mit IEC B5/B14  
Eingangsfansch  
075.....: Größe von Gehäuse  
03.....: Mit Flansch und Hohltriebsschwelle  
A11.....: Motor typ 112, B5 Motorflansch

ET063.01-07

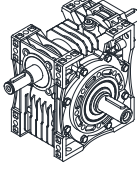

E.....: E serie Getriebe  
T.....: Vollwelleneingang ohne Motor  
063.....: Größe von Gehäuse  
01.....: Vollwelle  
07.....: Doppelte Eingangsschwelle

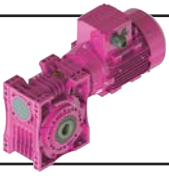

# Genel Bilgiler

## General Information

### Einführung

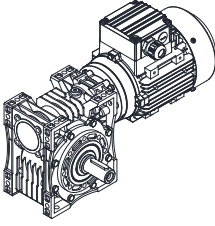
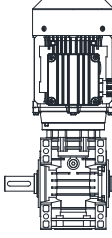
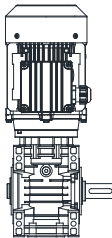
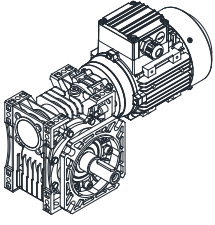
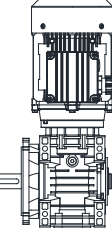
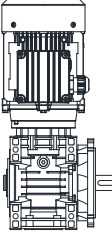
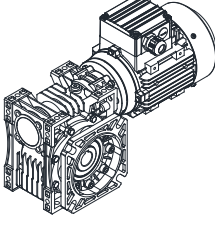
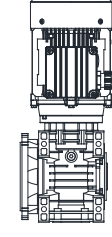
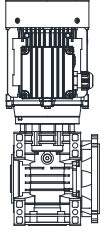

Redüktör Çıkış Özelliği / Gearbox Output Shaft and Flange Arrangement / Eigenschaft des Ausgangs

Redüktör Çıkış Özelliği Gearbox Output Specification Eigenschaft des Ausgangs	R	L
 E..01		
 E..02		
 E..03		

### Klemens Pozisyonları

Aşağıda gösterildiği gibi klemens kutuları farklı açılarda pozisyonlarda olabilir (A,B,C). Doğru pozisyon için ilgili ölçü sayfasını dikkate alınız.

### Terminal Box Positions

Terminal Boxes can be at different angular positions (A,B,C) as shown below. Please take in to account related gearbox dimension pages for right position.

### Klemmenkastenpositionen

Klemmenkasten können unterschiedliche Stellungen nehmen, siehe unten. (A,B,C) Bitte beachten Sie die Abmessungsseiten für die richtige Position.

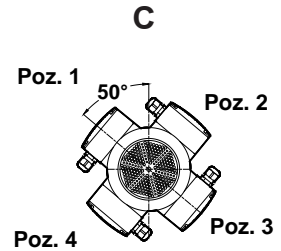
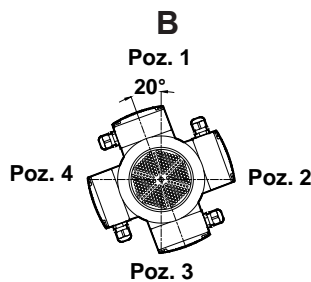
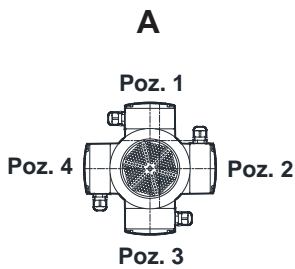

### Klemens Kablo Çıkış Pozisyonları

Kablo çıkış pozisyonları motor üstünden bakarak sağ veya sol olarak aşağıdaki gibi seçilebilir.

### Terminal Box Cable Output Positions

Terminal box cable output positions can be selected as right side or left side according to top view of terminal box.

### Kabelaşang von der Klemmenkasten

Kabelaşangseite von der Klemmenkasten kann als links oder rechts gemäß Blickrichtung oben von dem Motor ausgewählt werden.

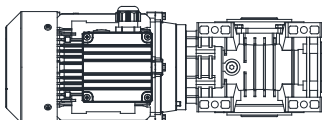

A tipi kablo çıkışı / A type Cable Output / Kabelaşang A

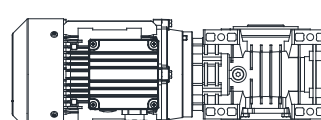

B tipi Kablo Çıkışı / B type Cable output / Kabelaşang B

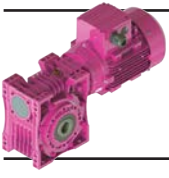

# Genel Bilgiler

## General Information

### Einführung



#### Moment kolu Pozisyonları

Moment kolu pozisyonları aşağıdaki gibidir.

#### Torque Arm Positions

Torque arm positions are shown on below.

#### Stelle Von Drehmomentstütze

Drehmomentstützestellungen wurden unten dargestellt.

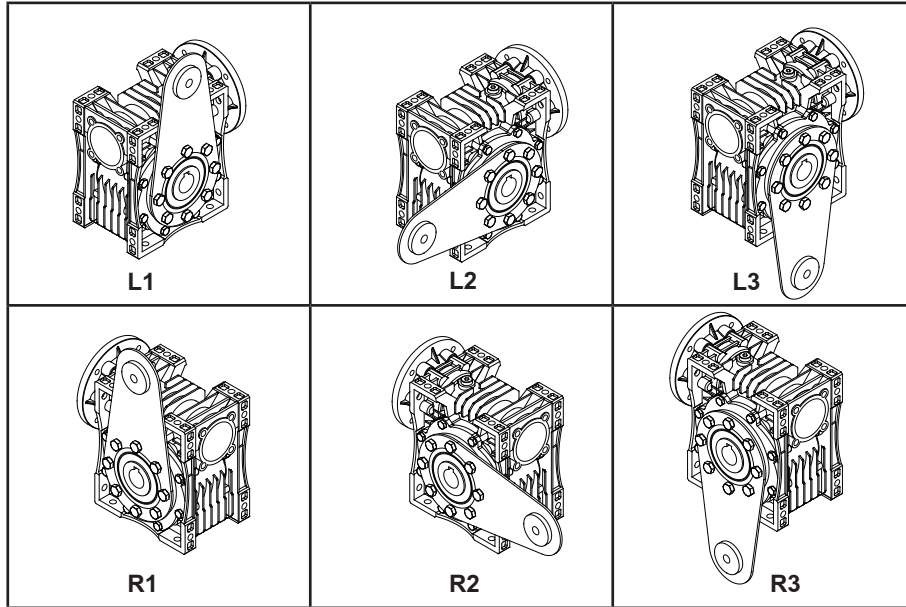
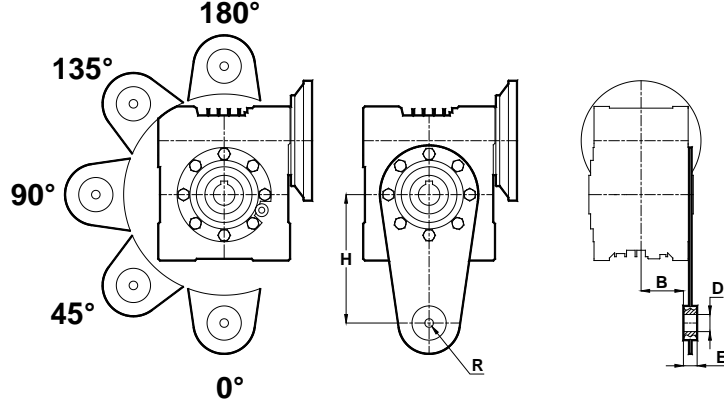

Tipi Type Typ	b	e	d	h	R	Parça No. Part No. Teil Nr.
EX030	22	14	10	85	25	9E030
EX040	31	14	10	100	25	9E040
EX050	38	16	10	100	32	9E050
EX063	49,5	16	10	150	36	9E063
EX075	46,5	25	20	200	45	9E075
EX080	49,5	25	20	200	45	9E080
EX100	57,5	30	25	250	50	9E100
EX125	72	30	25	300	55	9E125



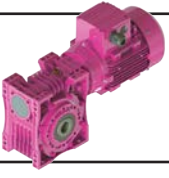

# Genel Bilgiler

## General Information

### Einführung



#### Redüktör Dönüş Yönleri

Giriş mili dönüş yönüne göre çıkış mili dönüş yönleri aşağıdaki gibidir.

#### Direction of Rotation

Output shaft rotation directions according to the input shaft rotation directions are as follows.

#### Getriebedrehrichtungen

Drehrichtungen der Abtriebswelle in Abhängigkeit von den Antriebswellen sind wie folgt;

Tip / Type / Typ	Saat Yönünde / Clockwise / Rechtslauf CW	Saat Tersi Yönünde / Counter Clockwise / Linkslauf CCW
ET...01		
ET...-NT..		
ET...01-ET...		

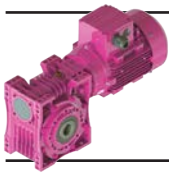

# Genel Bilgiler

## General Information

### Einführung



#### Motor Büyüklüğüne Göre Geometrik Mümkün Çevrim Oranları

Geometrically Possible Combinations of Ratios According to Motor Size  
Geometrisch mögliche Kombinationen von Übersetzungen nach Motorbaugröße

#### Motor Büyüklüğü / Motor Size / Motorbaugröße

Tip Type Typ	Kademe Stages Stufen	56	63	71	80	90	100	112	132
E..030..	W	5,25-80	5,25-80	-	-	-	-	-	-
E..040..	W		8-100	8-100	-	-	-	-	-
E..040-030..	W+W	84-3720	84-3720	-	-	-	-	-	-
E..050..	W	-	19-100	7,25-100	7,25-100	7,25-100	-	-	-
E..050-N01..	W+H	-	87-498	87-498	87-498	-	-	-	-
E..050-030..	W+W	138-4980	138-4980	-	-	-	-	-	-
E..063..	W	-	-	7,25-100	7,25-100	7,25-100	-	-	-
E..063-N01..	W+H	-	117-600	117-600	117-600	-	-	-	-
E..063-030..	W+W	210,25-4920	210,25-4920	-	-	-	-	-	-
E..075..	W	-	-	-	7,5-100	7,5-100	7,5-100	7,5-100	-
E..075-N11..	W+H	-	-	111,75-745	111,75-745	-	-	-	-
E..075-040..	W+W	-	-	60-6200	60-6200	-	-	-	-
E..080..	W	-	-	-	7,5-110	7,5-110	7,5-110	7,5-110	-
E..080-N11..	W+H	-	-	111,75-819,5	111,75-819,5	-	-	-	-
E..080-040..	W+W	-	180-5084	180-5084	-	-	-	-	-
E..100..	W	-	-	-	7,5-107	7,5-107	7,25-107	7,25-107	-
E..100-N11	W+H	-	-	149-797,15	149-797,15	-	-	-	-
E..100-050..	W+W	-	180-5084	180-5084	180-5084	180-5084	-	-	-
E..125..	W	-	-	-	-	7,25-107	7,25-107	7,25-107	7,25-62
E..125-N21..	W+H	-	-	125,58-516,81	125,58-516,81	125,58-516,81	-	-	-
E..125-063	W+W	-	184,88-5084	184,88-5084	184,88-5084	184,88-5084	-	-	-

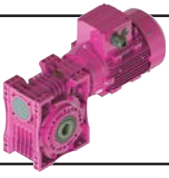

# Genel Bilgiler

## General Information

### Einführung



#### Servis Faktörü

Servis faktörü (fs) redüktörün çalıştığı şartlar ile uyumlu olması için gerekli olan emniyet katsayısıdır. "fs =1" Düzgün ve sakin yüklerde, günlük sekiz saat ve saatte yüz start çalışmayı karşılar.

Aşağıdaki etkenlere bağlıdır:

- Günlük çalışma süresi
- Yük sınıfı
- Bir saatteki start sayısı
- Redüktör tahrik tipi
- Diğer gözlemler

Bu etkenleri göz önüne aldığımızda, gerekli servis faktörünü belirlemek için:

1. Makinanın günlük çalışma süresini tespit ediniz.
2. Makinanın ne türde yükler verdiğini tespit ediniz (Sayfa 20-21).

- U - Düzgün ve sabit yükler
- M - Orta darbeli yükler
- H - Ağır darbeli yükler

Yük sınıfının daha teknik seçimi için rotora indirgenmiş toplam atalet momenti formülünden faydalanabilirsiniz (Sayfa 21).

3. Saatteki start sayısını tespit ediniz.
4. İlk üç maddeye bağlı servis faktörünü aşağıdaki tablodan seçiniz.

5. fs Redüktörümüzün tahrik tipine bağlı olarak "k" katsayısı ile çarpılarak artırılır.

- k=1 :Elektrik motoru veya hidromotor  
k=1.25 :İçten yanmalı çok silindirli motor  
k=1.5 :İçten yanmalı tek silindirli motor

#### Service Factor

Service Factor (fs) is a safety coefficient, which takes into account the different running conditions of the driven machine. "fs=1" is used for uniform loads 8 hours working per day and up to 100 starts per hour.

Service factor depends on:

- Running time
- Nature of load
- Frequency of starting
- Driver type
- Other considerations

For the right selection of the needed service factor for your machine;

1. Determine the running time of driven machine.
2. Select the nature of load of driven machine (Page 20-21).

- U - Uniform loads
- M - Moderate loads
- H - Heavy shock loads

For a better selection, the nature of load can be calculated from the formulas given (page 21).

3. Determine frequency of starting.
4. After determining the above mentioned factors, the service factor can be easily selected from the table given below.
5. The selected service factor multiplied with the factor "k" according to the driver type;

- k=1 :Electric motor or Hydraulic motor  
k=1.25 :Multicylinder internal combustion engine  
k=1.5 :Single cylinder internal combustion engine

#### Betriebsfaktor

Der Betriebsfaktor (fs) ist ein Sicherheitsfaktor für die Getriebe, damit sie unter den Betriebsbedingungen sicher arbeiten. "fs =1" steht für gleichförmige Belastung, 8 Stunden pro Tag und bis zu 100 Schaltungen pro Stunde.

Betriebsfaktor ist abhängig von:

- Betriebsdauer
- Belastungsart
- Schalthäufigkeit
- Antriebsart
- Andere Faktoren

Um die richtigen Betriebsfaktor festzulegen;

1. Betriebsdauer der angetriebenen Maschine bestimmen.
2. Belastungsart der angetriebenen Maschine auswählen (Seite 20-21).

- U - Gleichförmige Belastung
- M - Ungleichförmige Belastung
- H - Stark ungleichförmige Belastung

Um eine bessere Auswahl zu treffen, können die Belastungsarten mit den angegebenen Formeln (Seite 21) errechnet werden.

3. Schalthäufigkeit bestimmen.
4. Nach Bestimmen der oben angegebenen Werte, können die Betriebsfaktoren von der unten stehenden Tabelle entnommen werden.
5. Der ausgewählte Betriebsfaktor muß mit dem Faktor "k" abhängig von der Antriebsart multipliziert werden

- k=1 :Elektromotor oder Hydraulikmotor  
k=1.25 :Vielzylindermotor  
k=1.5 :Einzylindermotor

Günlük Çalışma Süresi  
Operating Time hour / Day  
Laufzeit Std. / Tag

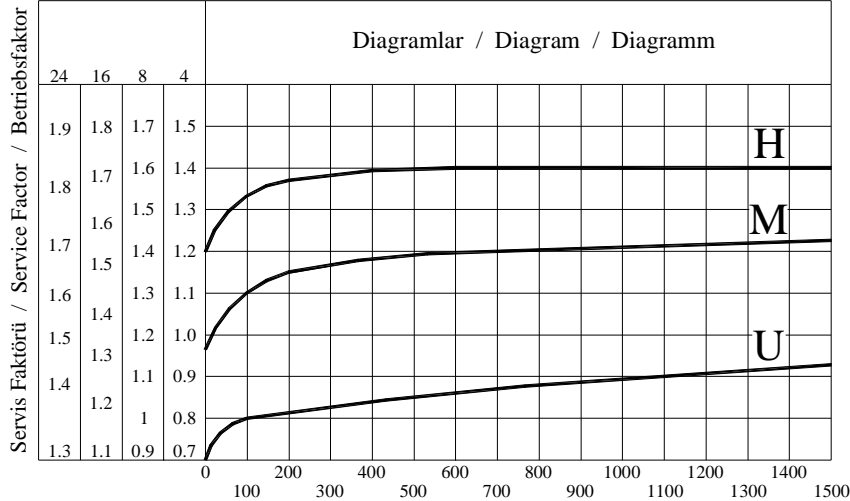

Start sayısı / Saat  
Cycle / Hour  
Schaltungen / Std.

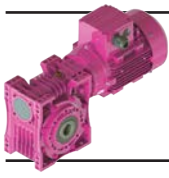

# Genel Bilgiler

## General Information

### Einführung



#### Yük Sınıflandırması

##### Krenler:

- U - Kaldırma Dişlileri
- Palanga Dişlileri
- M - Bomlu Vinç Dişlileri
- Yana Döndürme Dişlileri
- H - Yürütme Dişlileri

##### Pompalar:

- U - Santrifuj Pompalar (ince sıvı)
- M - Santrifuj Pompalar (yarı sıvı)
- H - Basınçlı Pompalar
- Dalgıç Pompalar

##### Taş ve Kil İşleme Makinaları:

- H - Çekiçli Değirmenler
- Döner Fırınlr
- Dövücü Değirmenler
- Kırıcılar
- Küreli Değirmenler
- Tuğla Presi
- Tüp Değirmenler

##### Tekstil Makinaları:

- M - Basma ve Boyama Makinaları
- Dokuma Tezgahları
- Hallac Makinaları
- Harman Makinaları
- Taneleme (Debegat )Tekneleri

##### Yağ Sanayi:

- M - Besleme Pompaları
- Döner Delme Teçhizatları

##### Yiyecek Sanayi:

- M - Kutu Bıçaklar
- Kutu Kaplama
- Mayalama Tekneleri
- H - Kenar Açma

##### Çamaşır Yıkama Makinaları:

- M - Döner Kurutucular
- Yıkama Makinaları

##### Hadde Makinaları:

- M - Hız Ayarlı Silindirler
- Sabit Silindirler
- Sarma Makaraları
- Tel Çekme
- H - Çubuk Kesme Makinaları
- Döner Tablalar (büyük)
- Kabuk Sıyırma Makinaları
- Plaka Haddeleme
- Silindir Haddeleme
- Soğuk Haddeleme

#### Load Classification

##### Cranes:

- U - Hoist Gears
- Lifting Gears
- M - Defrocking jib Gears
- Slowing Gears
- H - Travelling Gears

##### Pumps:

- U - Centrifugal Pumps (light liquids)
- M - Centrifugal Pumps (semi liquid)
- H - Pressure Pumps
- Plunger Pumps

##### Stone and Clay Working Machines:

- H - Hammer Mills
- Rotary Kilns
- Beater Mills
- Breakers
- Ball Mills
- Brick Presses
- Tüp Mills

##### Textile Machines:

- M - Printing and Dyeing Machines
- Looms
- Willow
- Batcher
- Tanning Vats

##### Oil Industry:

- M - Pipeline Pumps
- Rotary Drilling Equipment

##### Food Industry:

- M - Cane Knives
- Cane Crushers
- Mach Tubs
- H - Cane Mills

##### Laundries:

- M - Tumblers
- Washing Machines

##### Metal Rolling Mills:

- M - Roller Adjustment Drives
- Roller Straightened
- Winding Machines
- Wire Drawing Benches
- H - Billet Shears
- Rotary Tables (heavy)
- Descaling Machines,
- Sheet Mills
- Manipulators
- Cold Rolling Mills

#### Belastungsart

##### Krananlagen:

- U - Einziehwerke
- Hubwerke
- M - Schwenkwerke
- Wippwerke
- H - Fahrwerke

##### Pumpen:

- U - Kreiselpumpen (leichte Flüssigkeit)
- M - Kreiselpumpen (zahe Flüssigkeit)
- H - Prebpumpen
- Plungerpumpen

##### Stein- und Erdebearbeitende Maschine

- H - Hammermühlen
- Drehofen
- Schlagmühlen
- Brecher
- Kugelmühlen
- Ziegelpressen
- Rohrmühlen

##### Textilmaschinen:

- M - Drukerei
- Farbereimachinen
- Aufwickler
- Webstuhle
- Gerbfasser
- Reibwolfe

##### Erdölgewinnung:

- M - Pipeline Pumpen
- Rotative Bohranlagen

##### Nahrungsmittelmachinen:

- M - Rohrschneiden
- Knetmaschinen
- Maichen
- H - Rohrmühlen

##### Waschereimaschinen:

- M - Trommeltrockner
- Waschmaschinen

##### Wälzwerke:

- M - Rollenrichtmaschinen
- Walzenantriebe
- Drahtzuge
- Haspeln
- H - Blechscheren
- Rollgänge (schwer)
- Knüppelscheren
- Schöpfscheren
- Stranggubanlagen
- Kaltwälzwerke

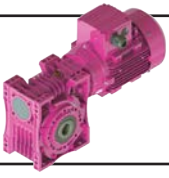

# Genel Bilgiler

## General Information

### Einführung



#### İnşaat Makinaları:

- M - Beton Mikserleri  
- Ağır Yük Asansörleri

#### Kağıt Makinaları:

- H - Islak Presler  
- Kağıt Hamur Makinaları  
- Kurutma Silindirleri  
- Perdahlama Silindirleri

#### Kauçuk Makinaları:

- M - Kalenderler  
- Mikserler  
H - Extruderler  
- Hamur Karma  
- Silindirler

#### Kimya Sanayi:

- M - Agidatörler (yarı sıvı)  
- Kurutma Merdaneleri  
- Mikserler ve Silindirleri

#### Konveyörler:

- M - Bant Ceppli Konveyörler  
- Çelik Bantlı Konveyörler  
- Dökme Yüklü Kayışlı Konv.  
H - Yük Asansörleri  
- Parça Yüklü Kayışlı Konv.

#### Building Machines:

- M - Concrete Mixers  
- Hoist

#### Paper Machines:

- H - Wet Presses  
- Pulpers  
- Drying Cylinders  
- Glazing Cylinders

#### Rubber Machinery:

- M - Calenders  
- Mixers  
H - Extruders  
- Pug Mills  
- Rolling Mills

#### Chemical Ind.:

- M - Aggidators (semi- liquid)  
- Drying Drums.  
- Mixers and Rolling Mills

#### Conveyors:

- M - Band Pocket Conveyors  
- Steel Belt Conveyors  
- Belt Conveyors  
H - Hoists  
- Bulk Belt Conveyors

#### Baumaschinen:

- M - Betonmischermaschinen  
- Bauaufzüge

#### Papiermaschinen:

- H - Naßpressen  
- Gautschen  
- Trockenzylinder  
- Glattzylinder

#### Kunststoffmaschinen:

- M - Kalender  
- Mischer  
H - Extruder  
- Knetwerke  
- Wälzwerke

#### Chemische Industrie:

- M - Rührwerke (leichte Flüssig.)  
- Trockentrommeln  
- Mischer und Wälzwerke

#### Förderanlagen:

- M - Gurtaschenbecherwerke  
- Stahlbandförderer  
- Gurtbandförderer (Schüttgut)  
H - Schrägaufzüge  
- Gurtbandförderer(Stückgut)

U	<b>Uniform Yük</b> Uniform Loads Gleichförmige Last	$F_i < 0,25$
M	<b>Orta Darbeli Yük</b> Moderate Loads Ungleichförmige Last	$F_i < 3$
H	<b>Darbeli Yük</b> Heavy Shock Loads Starke ungleichförmige Last	$F_i < 10$

$$J'_{ext} = \frac{J_{ext}}{i^2}$$

$$F_i = \frac{J'_{ext}}{J_{rotor}}$$

$J'_{ext}$  : **Motor miline indirgenmiş toplam dış atalet momenti**  
External moments of inertia reduced to the motor shaft  
Externe massenträgheitsmomente reduziert auf Motorwelle

$i$  : **Tahvil oranı**  
Transmission ratio  
Übersetzung

$J_{rotor}$  : **Motorun atalet momenti**  
Moments of inertia to the motor  
Massenträgheitsmoment

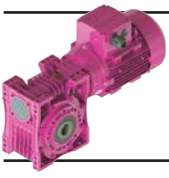

# Genel Bilgiler

## General Information

### Einführung



### Radyal Yükler

Çıkış miline gelebilecek radyal ve eksenel yükler yatak ömrüne göre belirlenmiş ve tablolar halinde verilmiştir. Bu tablolarda verilen  $F_{qam}$  güvenilir radyal yükü emniyet katsayısı 1 için ve yükün mil ortasını yüklediği durum için verilmiştir. Darbeli yüklerin olması ( $f_s=1$ ) durumunda izin verilen radyal yük değerleri servis faktörü kadar azaltılmalıdır. Verilen radyal ve eksenel yükler kuvvetin en kötü açı şartında etki ettiği durum için verilmiştir. Mil ucuna gelen kuvvetin açısına göre daha yüksek radyal yükler mümkündür (Firmamıza danışınız). Bağlantı şekline göre oluşan radyal yük  $F_q$  sayfa 23 de verilen formüller yardımı ile hesaplanır.

Redüktör seçiminde ;

$$\begin{aligned} F_{qa} &\leq F_{qam} \\ F_{qe} &\leq F_{qem} \end{aligned}$$

şartı göz önünde tutulmalı. Eğer etkiyen radyal kuvvet milin orta noktasında değil ise verilen güvenilir değerler aşağıda verilen formül ile düzeltilmesi gerekir.

$$F_{qam}' = F_{qam} \cdot \frac{t}{y + u}$$

$$F_{qem}' = F_{qem} \cdot \frac{t}{y + u}$$

"t", "y" Değerleri aşağıda verilmiştir. "u" Değeri görüldüğü gibi kuvvetin uygulama noktasıdır.

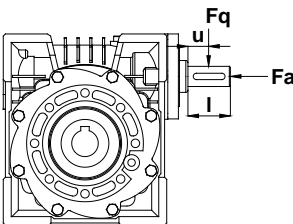
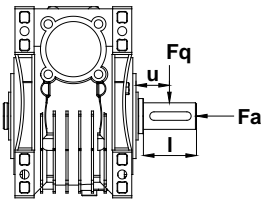

### Overhung Loads

The permissible overhung loads are calculated by considering working life and is listed on the tables. The given permissible overhung loads  $F_{qam}$  are based on safety factor 1 and are valid for forces which are applied to the midpoint of the shaft.

For shock loading ( $f_s = 1$ ) permissible radial loads must be divided with service factor. The listed permissible overhung loads are based on the worst loading direction. Higher overhung loads can be applied for different loading directions (Please ask if requested). The effective overhung load at the gearbox shaft  $F_q$  will be determined with the given formulas on page 23.

In Selection ;

$$\begin{aligned} F_{qa} &\leq F_{qam} \\ F_{qe} &\leq F_{qem} \end{aligned}$$

these formulas must be taken into consideration. If the load is not applied at the midpoint of the shaft; the given permissible load must be corrected with the following formulas.

$$F_{qam}' = F_{qam} \cdot \frac{t}{y + u}$$

$$F_{qem}' = F_{qem} \cdot \frac{t}{y + u}$$

The values "t", "y" can be taken from the below table. The value "u" is the length of the application point as shown below.

### Querkräfte

Die in den nachfolgenden Tabellen angegebenen zulässigen Radialbelastungen  $F_{qam}$  gelten bei Kraftangriff auf die Mitte Wellenendes. Den Angaben liegt der Sicherheitsfaktor gleich 1 zu Grunde. Bei stoßartigen Belastungsfällen ist auch hier der entsprechende Betriebsfaktor ( $f_s=1$ ) zu berücksichtigen. Zulässige Axialkräfte  $F_{ama}$  oder  $F_{ame}$  wurden für den Fall mit schlechter Belastungsrichtung angegeben. Bei der Ermittlung der zulässige Querkräfte sind höhere Werte möglich (Bitte Rückfragen). Die auftretende Querkraft  $F_q$  ab der Getriebewelle wird wie in der nachfolgenden Formel bestimmt.

Bei dieser Auswahl;

$$\begin{aligned} F_{qa} &\leq F_{qam} \\ F_{qe} &\leq F_{qem} \end{aligned}$$

müssen die oben angegebenen Bedingungen berücksichtigt werden. Ist der Kraftangriff nicht auf Wellenmitte, so kann die zulässige Querkraft mit Hilfe der unten stehenden Formel auf jede beliebige Stelle umgerechnet werden.

$$F_{qam}' = F_{qam} \cdot \frac{t}{y + u}$$

$$F_{qem}' = F_{qem} \cdot \frac{t}{y + u}$$

Die Werte "t" und "y" sind in den nachfolgenden Tabellen angegeben. Der Wert "u" ist die Stelle des Kraftangriffs wie auf der nächsten Seite angegeben.

### Çıkış mili radyal kuvvet hesabı düzeltme katsayıları

Overhung Load correcting values on output shaft  
Korrigierungszahlen für Querkraft auf Ausgangswelle

Tip Type Typ	E.030	E.040	E.050	E.063	E..075	E.080	E.100	E.125
t	67	86	107	131	138,5	163	185	210
y	53	66	82	106	106	123	135	155
l	30	40	50	50	65	65	80	100

### Giriş mili Radyal kuvvet hesabı düzeltme katsayıları

Overhung load correcting values on input shaft  
Korrigierungszahlen für Querkraft auf Eingangswelle

Tip Type Typ	ET030	ET040	ET050	ET063	ET075	ET080	ET100	ET125
t	85	118	144	172,5	195	207	247	310
y	75	103	129	152,5	170	182	217	278
l	20	30	40	40	50	50	60	65

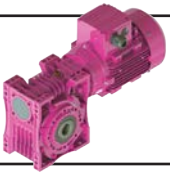

# Genel Bilgiler

## General Information

### Einführung



#### Radyal Yüklerin Hesabı

Radyal Yük  $F_q$  [N]'nin hesaplanmasında, gerekli tahrik momenti  $M$  [Nm], kasnak veya dişli çapı  $D$  [mm] olmak üzere aşağıdaki formüller kullanılır.



#### 1. Elastik Kaplin

Çalışma sırasında oluşan sapmalar kaplinin güvenlik sınırları içinde ise kuvvetler ihmal edilebilir.



#### 2. Düz Dişli (20° kavrama açısı)

$$F_q = \frac{2100 \times M_2}{D}$$



#### 3. Küçük Hızlarda Zincir Dişli ( $z > 17$ )

$$F_q = \frac{2100 \times M_2}{D}$$



#### 4. Triger Kayış

$$F_q = \frac{2500 \times M_2}{D}$$



#### 5. V Kayış

$$F_q = \frac{5000 \times M_2}{D}$$



#### 6. Gerdirme Makaralı Kayış

$$F_q = \frac{5000 \times M_2}{D}$$

#### Calc. Of Overhung Loads

Overhung Load  $F_q$  [N] is calculated with the following equations where required moment  $M$  [Nm] and hoop or gear diameter  $D$  [mm] is used.

#### 1. Elastic Coupling

If Elastic Coupling is working in its reliable working area, the overhung loads can be neglected.

#### 2. For Spur Gear (Pressure angle 20°)

$$F_q = \frac{2100 \times M_2}{D}$$

#### 3. For Chain Drive With Low Speed ( $z > 17$ )

$$F_q = \frac{2100 \times M_2}{D}$$

#### 4. For Triger Belt

$$F_q = \frac{2500 \times M_2}{D}$$

#### 5. For V Belt

$$F_q = \frac{5000 \times M_2}{D}$$

#### 6. Flat Belt With Spanning Pulley

$$F_q = \frac{5000 \times M_2}{D}$$

#### Berechnung der Querkräfte

Der Fall der radialen Belastung  $F_q$  [N] kann mit den angegebenen Gleichungen berechnet werden. Antriebsmoment  $M$  [Nm] und Zahnrad- oder Riemenscheiben Durchmesser  $D$  [mm].

#### 1. Elastische Kupplung

Wenn die elastische Kupplung in ihrem zulässigen Arbeitsbereich arbeitet, können die radialen Belastungen vernachlässigt werden.

#### 2. Stirnradgetriebe (Angriffswinkel 20°)

$$F_q = \frac{2100 \times M_2}{D}$$

#### 3. Kettenantrieb mit niedriger Geschwindigkeit ( $z > 17$ )

$$F_q = \frac{2100 \times M_2}{D}$$

#### 4. Zahnriemenantrieb

$$F_q = \frac{2500 \times M_2}{D}$$

#### 5. Keilriemenantrieb

$$F_q = \frac{5000 \times M_2}{D}$$

#### 6. Flachriemenantrieb mit Spannungstrommel

$$F_q = \frac{5000 \times M_2}{D}$$

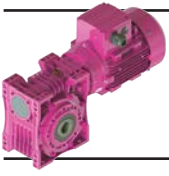

# Genel Bilgiler

## General Information

### Einführung



#### Sonsuz Vidalarda Termik Güç

Güç-devir tablolarında verilen nominal termik güç  $P_t$  değerleri, 70°C yağ sıcaklığını aşmayacak şekilde 20°C maksimum çevre sıcaklığında sürekli çalışma durumu için, redüktör girişine uygulanabilir maksimum güç değeridir. Gerçek termik güç  $P_{tg}$  değeri, yukarıda bahsedilen  $P_t$  değerinden yüksek olabilir.

$$P_{tg} = P_t \times k_t$$

Burada  $k_t$  değeri çevre sıcaklığı ve yüklem durumuna bağlı termik faktördür. Aşağıdaki tablodan  $k_t$  seçilebilir.

Redüktöre uygulanan giriş gücü  $P_g$  değeri verilen  $P_{tg}$  değerinden daha düşük olmalıdır. ( $P_g < P_{tg} = P_t \times k_t$ ). Eğer  $P_g > P_{tg}$  ise özel imkanlar araştırılmalıdır (bize danışınız).

Termik güç değeri sürekli çalışma süresi 1 - 3 saati geçmiyorsa ve bu sürekli çalışmadan sonra redüktör çevre sıcaklığına düşene kadar çalışmıyorsa ihmal edilebilir. (yaklaşık 1 - 3 saat).

#### Thermal Power for Worm Gearboxes

Nominal thermal power  $P_t$ , indicated in our catalogue in performance tables can be applied at the gear reducer input when operating in continuous duty at a maximum ambient temperature of 20° C without exceeding 70° C oil temperature. Thermal power  $P_{tg}$ , can be higher than the nominal  $P_t$ , described above, as per the following formula,

$$P_{tg} = P_t \times k_t$$

where  $k_t$  is the thermal factor depending on ambient temperature and type of duty as indicated in the table below.

Applied power  $P_g$ , should be less than or equal to the  $P_{tg}$  value ( $P_g < P_{tg} = P_t \cdot k_t$ ). If  $P_g > P_{tg}$ , explore the possibilities and consult us.

Thermal power need not be taken into account when maximum duration of continuous running time is 1 - 3 h followed by shutdown periods long enough to restore the gear reducer to near ambient temperature (approx. 1 - 3 h).

#### Thermische Leistung für Schneckenradgetriebe

Die Werte in den Leistung - Drehzahl Tabellen geben die Nennwärmeleistung  $P_t$  an. Unter dieser Größe versteht man diejenige Leistung, die bei Dauerbetrieb und max. Umgebungstemperatur von 20°C an die Antriebswelle des Getriebes angelegt werden kann, ohne Getriebeöltemperatur 70°C zu überschreiten. Die Wärmeleistung  $P_{tg}$  kann höher liegen als die beschriebene Nennwärmeleistung  $P_t$ . Es gilt die Formel

$$P_{tg} = P_t \times k_t$$

wobei  $k_t$  der Wärmefaktor ist, dessen Werte im Verhältnis zur Umgebungstemperatur und Betriebsart stehen und von der Tafel entnommen werden können.

Die  $P_g$  Werte müssen überprüft werden, ob die Leistung  $P_g$  kleiner oder gleich der Wärmeleistung  $P_{tg}$  ist ( $P_g < P_{tg} = P_t \cdot k_t$ ). Bei  $P_g > P_{tg}$  eventuelle Verwendungen bitte rückfragen.

Die Wärmeleistung braucht nicht berücksichtigt zu werden, wenn der Dauerbetrieb höchstens 1 - 3 Stunden währt und sich daran genügend lange Ruhezeiten (ca. 1 - 3 Stunden) anschließen, damit im Getriebe wieder ca. die Umgebungstemperatur herrscht.

Maksimum Çevre Sıcaklığı [°C] Maximum Ambient Temperature [°C] Maximale Umgebungstemperatur [°C]	Çalışma Türü için $k_t$ / $k_t$ for Operation Type / $k_t$ für Betriebsarten				
	Sürekli (S1)	Duraksamalı çalışma şekli (S3...S6) 60 dakikada çalışma yüzdesi			
	Continuously (S1)	Duty on intermittent load (S3...S6) Intermittence ratio for 60 minutes running			
	Dauerhaft (S1)	Betrieb bei unterbrochener Belastung (S3...S6) Verhältnis in Prozent bei 60 Minuten intermittierendem Betrieb			
	-	%60	%40	%25	%15
40	0,8	0,9	1	1,2	1,3
30	0,9	1,1	1,2	1,4	1,5
20	1	1,2	1,4	1,5	1,7
10	1,2	1,4	1,5	1,7	1,9



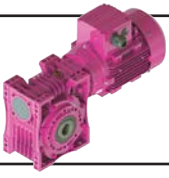

# Genel Bilgiler

## General Information

### Einführung



#### Verim

Redüktörlerde verim  $\eta = P_{N2} / P_{N1}$  oranından elde edilir. Bu değer redüktörün normal şartlarda çalıştığı, iyi yağlama yapıldığı ve yükün nominal değere yakın olduğu taktirde geçerlidir. Sonsuz Vidalı redüktörlerde ilk 50 saatlik çalışma süresi içinde verim sonsuz vida tablolarında verilen değerlerden aşağıdaki yüzdeler kadar (ağız sayılarına bağlı olarak) daha düşük olacaktır;

z1= 1 ; %12  
z1= 2 ; %6  
z1= 3 ; %3

Statik verim  $\eta_s$  start anında oluşan verimdir ve dinamik verim  $\eta'$  nin çok altındadır. Motor nominal devrine ulaştığında redüktörün verimi katalogta verilen değerlere ulaşacaktır. Helisel dişli tiplerde katalogta verim değeri verilmemiştir.

Helisel dişli tiplerin (monoblok, delik milli ve yatık) verimleri kademe başına 0,98 civarındadır.

İnvers verim  $\eta_{inv}$  çıkış mili tarafından redüktöre tahrik gelmesi ile oluşan verimdir ve her zaman  $\eta'$  dan küçüktür. Bu değer aşağıdaki gibi hesaplanır.

$$\eta_{inv} = 2 - \frac{1}{\eta}$$

Benzer şekilde statik invers verim:

$$\eta_{Sinv} = 2 - \frac{1}{\eta_s}$$

#### Efficiency

Efficiency is derived from the  $\eta = P_{N2} / P_{N1}$  ratio. The value obtained will be valid assuming normal working conditions, correct lubrication and a load near the nominal value. In worm gearboxes, during the initial working period (about 50 hours) efficiency will be less than the catalogue values (according worm start number) referred to the values below ;

z1=1 ; 12%.  
z1=2 ; 6%.  
z1=3 ; 3%

Static efficiency  $\eta_s$  is the efficiency on starting, and is less than  $\eta$ ; as speed picks up gradually, efficiency will rise correspondingly until the catalogue value is reached. On the helical gearboxes the efficiency is not given on the performance tables.

In these types (Monoblock, Hollow Shaft and Horizontal type gearboxes) the efficiency is about 0,98 for each stage.

Inverse efficiency  $\eta_{inv}$  that produced by the worm wheel as drive is always less than  $\eta$ . It can be calculated approximately as follow:

$$\eta_{inv} = 2 - \frac{1}{\eta}$$

Likewise Static inverse efficiency;

$$\eta_{Sinv} = 2 - \frac{1}{\eta_s}$$

#### Wirkungsgrad

Wirkungsgrad ergibt sich aus dem Verhältnis  $\eta = P_{N2} / P_{N1}$ . Die damit berechneten Werte beziehen sich auf normale Betriebsbedingungen, einwandfreie Schmierung und dem Nennwert ungefähr gleicher Belastung. Bei Schneckengetrieben der Wirkungsgrad erweist sich in den ersten Betriebsstunden (ca. 50 Std.) etwas niedriger. Es ist abhängig von Zähnezahl wie unten angegeben.

z1= 1 ; 12%  
z1= 2 ; 6%  
z1= 3 ; 3%

Der statische Wirkungsgrad  $\eta_s$  beim Anlauf liegt weit unter den Tabellenwerten; mit Anstieg der Drehzahl erhöht sich der Wirkungsgrad bis auf die Tabellenwerte. Bei Stirnradgetrieben ist Wirkungsgrad nicht angegeben. Für Stirnradgetrieben (Monoblok, Flachgetriebe und Horizontal type getrieben) Wirkungsgrad ist ungefähr 0,98 für jede Stufe.

Den umgekehrten Wirkungsgrad  $\eta_{inv}$  hat man, wenn der Antrieb vom Schneckenrad erteilt wird. Er ist stets kleiner und kann annäherungsweise durch die Formeln ausgedrückt werden.

$$\eta_{inv} = 2 - \frac{1}{\eta}$$

Statische umgekehrten Wirkungsgrad;

$$\eta_{Sinv} = 2 - \frac{1}{\eta_s}$$

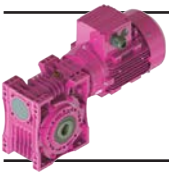

# Genel Bilgiler

## General Information

### Einführung



#### Sonsuz Vidada Otoblokajlık:

##### A ) Dinamik Otoblokaj

Dinamik otoblokajlı bir sonsuz vida redüktörünün tahrik tarafında motor momenti ile sonsuz vida, pervane, kaplin gibi bağlantı elemanlarının atalet momentleri ortadan kalktıktan sonra vidanın ani olarak kilitlemesi olayıdır. Dinamik otoblokaj  $\eta < 0,5$  olduğunda gerçekleşir. Fren yardımı olmadan yükü durdurmak ve tutmak istendiğinde gerekli olur. Sürekli vibrasyonlu durumlarda dinamik otoblokaj elde edilemeyebilir.

##### B ) Statik Otoblokaj

Statik otoblokaj çıkış mili tarafından hiç bir hareketin iletilmediği durumda olan otoblokaj'dır.

Statik otoblokaj  $\eta_s < 0.5$  aralığı içindedir. Fakat verimin zaman içinde yükselebileceği göz önünde tutularak  $\eta_s \leq 0.4$  ( $\gamma_m < 5^\circ 30'$ ) olarak kabul edilmesi tavsiye edilir. Sürekli vibrasyonlu durumlarda statik otoblokajlık elde edilemeyebilir.

Eğer  $\eta_s$  statik verimi  $0.5 \leq \eta_s < 0.55$  ( $7^\circ < \gamma_m \leq 11^\circ$ ) aralığında olursa düşük statik geri dönebilirlik (çıkış şaftı tarafına vibrasyon ve/veya yüksek moment uygulandığında döndürmek mümkün) oluşur.

Eğer  $\eta_s \geq 0.55$  ( $\gamma_m \geq 11^\circ$ ) olursa tam statik geri dönebilirlik (çıkış şaftı tarafından döndürmek mümkün) oluşur. Bu durum çıkış mili tarafından gelen yükleri otoblokaj etmesi gerekmeyen yumuşak kalkışlı durumlar için geçerlidir.

#### Irreversibility by Wormgears:

##### A ) Dynamic Irreversibility

*Dynamic irreversibility is a self blocking event on the driving side, directly after the moment of inertia of driving motor and moment of the driving side elements (like coupling, rotor shaft, cooling fan etc.) settles down to zero. There is dynamic irreversibility if  $\eta < 0,5$ . This state becomes necessary wherever there is a need for stopping and holding the load, even without the aid of a brake. Where continuous vibration occurs, dynamic irreversibility may not be obtainable.*

##### B ) Static Irreversibility

*A gear unit or geared motor is statically irreversible (that is, rotation cannot be imparted by way of the low speed shaft) when  $\eta_s < 0.5$ . This is a state necessary to keeping the load standstill; taking into account, however, that efficiency can increase with time spent in operation, it would be advisable to assume  $\eta_s \leq 0.4$  ( $\gamma_m < 5^\circ 30'$ ). Where continuous vibration occurs, static irreversibility may not be obtainable.*

*A gear reducer or geared motor has low static reversibility (i.e. rotation may be imparted by way of the low speed shaft with high torque and / or vibration) when  $0.5 < \eta_s < 0.55$  ( $7^\circ < \gamma_m < 11^\circ$ ).*

*A gear reducer or geared motor has complete static reversibility (i.e. rotation may be imparted by way of the low speed shaft) when  $\eta_s \geq 0.55$  ( $\gamma_m \geq 11^\circ$ ). This state is advisable where there is a need for easy startup of the gear reducer by way of the low speed shaft.*

#### Schneckengetriebe Selbsthemmung:

##### A ) Dynamische Selbsthemmung

Schneckengetriebe oder Getriebemotoren sind dynamisch selbsthemmend wenn  $\eta < 0,5$  ist. Sofortiges Einwirkung der Selbsthemmung, sobald die Drehung der Schneckenwelle aufhört und Motormoment Trägheit der Schnecke, Schwungräder, Kupplungen und des Lüfters, Motors usw. überwindet. Diese Bedingung benötigt man in allen Fällen, wo man eine Last ohne Bremsvorrichtung stoppen und halten will. Bei ständig auftretenden Vibrationen lässt sich die dynamische Selbsthemmung nur schwer verwirklichen.

##### B) Stillstand Selbsthemmung

Schneckengetriebe oder -getriebemotoren sind im Stillstand selbsthemmend, wenn  $\eta_s < 0.5$  ist (Drehung von langsam laufender Welle aus nicht möglich). Diese Bedingung benötigt man in allen Fällen, wo man eine Last halten will. Da der Wirkungsgrad sich im Laufe des Betriebs erhöhen kann, sollte  $\eta_s \leq 0.4$  ( $\gamma_m < 5^\circ 30'$ ) am besten eingehalten werden. Bei ständig auftretenden Vibrationen lässt sich die Selbsthemmung im Stillstand nur schwer verwirklichen. Schneckengetrieben sind im Stillstand kaum selbsthemmend (Drehung von langsam laufender Welle aus nur mittels hoher Drehmomente und / oder durch das Auftreten von Vibrationen möglich) wenn  $0.5 < \eta_s < 0.55$  ( $7^\circ < \gamma_m < 11^\circ$ ) ist.

Schneckengetrieben sind nicht statisch selbsthemmend (Drehung von langsam laufender Welle aus möglich), wenn  $\eta_s \geq 0.55$  ( $\gamma_m \geq 11^\circ$ ) ist. Diese Bedingung ist ratsam, wo das Getriebe leichtgängig über die langsam laufende Welle angetrieben werden muss.

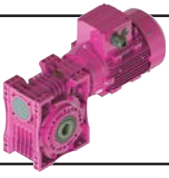

# Genel Bilgiler

## General Information

### Einführung



#### Eşdeğer Güç Hesabı

Sabit devirde, ancak değişken momentlerde (güçlerde) çalışan redüktörler için eşdeğer tork altındaki, eşdeğer güç hesaplanabilir. Bu eşdeğer güç kullanılarak bilinen sabit güçteki redüktör seçim yöntemi kullanılarak seçim yapılabilir. Burada ağırlıklı torka göre eşdeğer anma torku belirlenmektedir. Hesaplanan bu güçte çalışan redüktör, teorik olarak, değişken yüklerde çalışan redüktör ile aynı emniyet değerine ve ömre sahiptir.

Bir çevrim boyunca oluşan değişken torklar, en yüksek torktan, en düşüğe doğru yatay zaman eksenini boyunca sıralanır (bakınız alttaki şekil). Bu şekile göre eşdeğer tork şu formül ile hesaplanır;

$$T_e = \left( \frac{\Delta t_1 \times T_1^{6.6} + \dots + \Delta t_n \times T_n^{6.6}}{t} \right)^{\frac{1}{6.6}}$$

Eğer  $T_n$  değerleri (en düşük tork),  $T_e$ 'nin 0,5 katının altında ise, bu tork dilimi yok sayılarak, işlem tekrarlanır;

Eğer  $T_n < T_e \times 0.5$  ise

$$T_e = \left( \frac{\Delta t_1 \times T_1^{6.6} + \dots + \Delta t_{n-1} \times T_{n-1}^{6.6}}{t - \Delta t_n} \right)^{\frac{1}{6.6}}$$

Tüm  $T_n$  değerleri  $T_e$ 'nin 0,5 katının üzerinde ise, eşdeğer güç aşağıdaki gibi hesaplanır;

$$P_{eq} = P_N = \frac{T_e \times n}{9550}$$

Eşdeğer gücün bulunmasından sonra eşdeğer güç değeri kullanılarak, bu katalogta verilen redüktör seçimi bölümünde anlatılan adımlar uygulanarak redüktör seçimi tamamlanır.

#### Equivalent Power Rating Calculation

The equivalent power by an equivalent constant torque can be calculated for gearboxes working in constant speed but variable torques (or powers). Using this equivalent power it is possible to make a gearbox selection according to the usual gearbox selection method with constant torques. The equivalent torque will be determined according to the mean of dominating torques. The gearbox working in constant equivalent torque will theoretically have the same lifetime and safety compared to the variable torque one.

To calculate the equivalent torques, the variable torques in a cycle must be sorted from the maximal to the minimal on a horizontal time line (Check the graphic below). According to the graphic below the equivalent torque can be calculated with the following formula;

$$T_e = \left( \frac{\Delta t_1 \times T_1^{6.6} + \dots + \Delta t_n \times T_n^{6.6}}{t} \right)^{\frac{1}{6.6}}$$

If  $T_n$  (the lowest torque) is lower than 50 % of  $T_e$ , this torque part must be taken out of the torque graph and the calculation must be repeated;

If  $T_n < T_e \times 0.5$  then

$$T_e = \left( \frac{\Delta t_1 \times T_1^{6.6} + \dots + \Delta t_{n-1} \times T_{n-1}^{6.6}}{t - \Delta t_n} \right)^{\frac{1}{6.6}}$$

If all  $T_n$  values are higher than 50% of  $T_e$  then the equivalent power can be calculated by the following formula;

$$P_{eq} = P_N = \frac{T_e \times n}{9550}$$

After the equivalent power is determined the selection of gearbox is made according to the selection procedures given on the gearbox selection part in this catalogue.

#### Berechnung Äquivalenter Leistung

Die äquivalente Leistung bei äquivalenten Drehmoment kann für Getrieben mit konstanten Drehzahl und variablen Momente berechnet werden. Mit dieser Leistung kann das Getriebe ausgelegt werden, wie bei konstanten Leistung. Man bestimmt hiermit also die maßgebende Belastung. Das ausgelegte Getriebe erreicht theoretisch dem gleichen Lebensdauer und hat die gleiche Sicherheit.

Für die Berechnung der äquivalenten Drehmoment müssen die einzelnen Drehmomentanteile auf eine Zeitachse von größten bis zu kleinsten angeordnet werden (siehe unteres Bild). Das äquivalente Drehmoment wird nach folgender Formel berechnet;

$$T_e = \left( \frac{\Delta t_1 \times T_1^{6.6} + \dots + \Delta t_n \times T_n^{6.6}}{t} \right)^{\frac{1}{6.6}}$$

Wenn  $T_n$  (niedrigstes Drehmoment) kleiner als 50% von  $T_e$  ist, muss dieser Anteil vernachlässigt werden und die Berechnung soll neu durchgeführt werden;

Wenn  $T_n < T_e \times 0.5$  dann

$$T_e = \left( \frac{\Delta t_1 \times T_1^{6.6} + \dots + \Delta t_{n-1} \times T_{n-1}^{6.6}}{t - \Delta t_n} \right)^{\frac{1}{6.6}}$$

Wenn alle  $T_n$  Werte höher als 50% von  $T_e$  sind, dann wird die äquivalente Leistung nach folgender Formel berechnet;

$$P_{eq} = P_N = \frac{T_e \times n}{9550}$$

Nach Bestimmung der äquivalenter Leistung, erfolgt die Getriebeauslegung wie bei konstanter Leistung. Die Auswahlverfahren für konstante Leistung ist in diesem Katalog angegeben.

(Moment / Torque / Moment)

T [Nm]

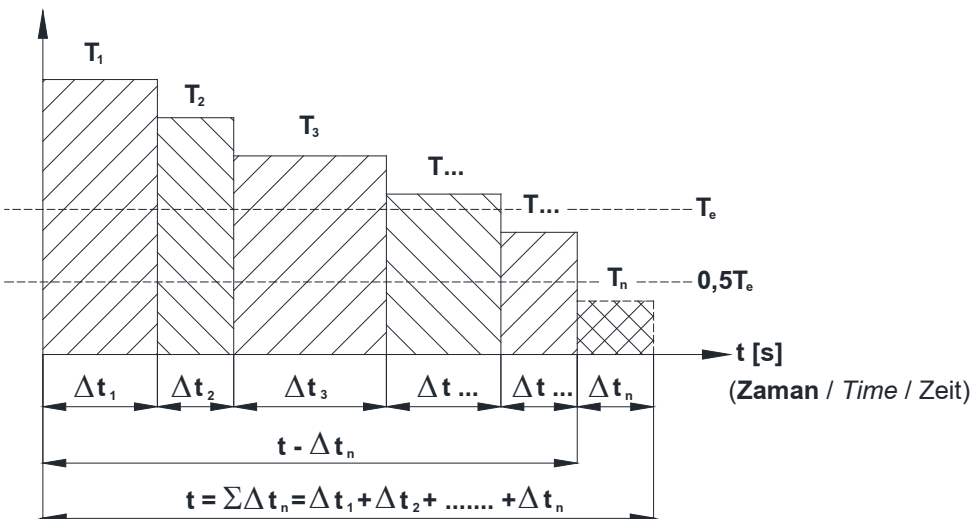

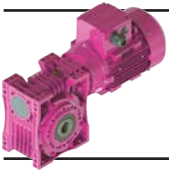

# Genel Bilgiler General Information Einführung



## Eşdeğer Güç Hesabı Örneği

Çift yönlü çalışan ham demir haddesi için aşağıdaki çalışma koşulları belirlenmiş;

### Veriler:

Toplam bir iş çevrimi: 2 dak.

1. Yük kademesi: 48 kNm, 30 s
2. Yük Kademesi: 32 kNm, 22 s
3. Yük Kademesi: 28 kNm, 15 s
4. Yük Kademesi: 16 kNm, 10 s
5. Yük Kademesi: 5 kNm, 43 s

Makina sabit devri: 50 d/dak

Redüktör seçimine esas olacak eşdeğer yük aranmaktadır.

### Çözüm:

Bir çevrimin toplam zamanı;

$$t = t_1 + t_2 + t_3 + t_4 + t_5 = 120 \text{ sn}$$

Eşdeğer Tork;

$$T_e = \left( \frac{30 \times 48^{6.6} + \dots + 43 \times 5^{6.6}}{120} \right)^{\frac{1}{6.6}}$$
$$= 39,2 \text{ kNm}$$

%50 eşdeğer tork;

$$0.5 \times T_e = 19.6 \text{ kNm}$$

Her bir tork dilimi bu değer üzerinde olmalı

$$T_4, T_5 < 0.5 \times T_e$$

%50 torkun altındakileri çıkararak hesabı tekrarlayalım;

$$t' = t - t_4 - t_5 = 120 - 43 - 10 = 67 \text{ s}$$

$$T_e = \left( \frac{30 \times 48^{6.6} + \dots + 15 \times 28^{6.6}}{67} \right)^{\frac{1}{6.6}}$$
$$= 42,9 \text{ kNm}$$

Moment ve devir değerlerini kullanarak eşdeğer gücümüzü hesaplayalım ;

$$P_{eq} = \frac{T_e \times n}{9550} = \frac{42,9 \times 1000 \times 50}{9550} \cong 225 \text{ kW}$$

Yukarıdaki güç ve devir değeri kullanılarak bu katalogta anlatılan seçim presüdüğü ile redüktör seçimi yapılabilir.

## Equivalent Power Rating Sample

The following data is given for a reversing blooming mill;

### Torque steps:

Total one cycle time: 2 min.

1st torque part: 48 kNm, 30 s

2nd torque part: 32 kNm, 22 s

3th torque part: 28 kNm, 15 s

4th torque part: 16 kNm, 10 s

5th torque part: 5 kNm, 43 s

Machine constant speed: 50 rpm

The equivalent power, which is required for gear unit selection, is to determine.

### Solution:

Total time in a cycle;

$$t = t_1 + t_2 + t_3 + t_4 + t_5 = 120 \text{ sn}$$

Equivalent Torque;

$$T_e = \left( \frac{30 \times 48^{6.6} + \dots + 43 \times 5^{6.6}}{120} \right)^{\frac{1}{6.6}}$$
$$= 39,2 \text{ kNm}$$

50% of Equivalent torque;

$$0.5 \times T_e = 19.6 \text{ kNm}$$

Every torque part must be lower then this value;

$$T_4, T_5 < 0.5 \times T_e$$

We are repeating the calculation by taking out the torque parts, which are below 50%;

$$t' = t - t_4 - t_5 = 120 - 43 - 10 = 67 \text{ s}$$

$$T_e = \left( \frac{30 \times 48^{6.6} + \dots + 15 \times 28^{6.6}}{67} \right)^{\frac{1}{6.6}}$$
$$= 42,9 \text{ kNm}$$

By using the equivalent torque and constant speed we calculate the equivalent power ;

$$P_{eq} = \frac{T_e \times n}{9550} = \frac{42,9 \times 1000 \times 50}{9550} \cong 225 \text{ kW}$$

Now by using the above calculated equivalent power and constant speed we can make the gearbox selection with the procedures described in this catalogue.

## Beispiel für Äquivalente Leistung

Die nachfolgenden Angaben sind für eine Blechreversierwalze;

### Drehmoment stufen:

Gesamte Zeit für einem Arbeitszyklus: 2 min.

Drehmomentanteil 1: 48 kNm 30 s

Drehmomentanteil 2: 32 kNm 22 s

Drehmomentanteil 3: 28 kNm 15 s

Drehmomentanteil 4: 16 kNm 10 s

Drehmomentanteil 5: 5 kNm 43 s

Maschine hat konstante Drehzahl: 50 U/min

Gesucht ist die äquivalente Leistung, die für die Getriebeauslegung nötig ist.

### Lösung:

Gesamte Zeit für einem Arbeitszyklus;

$$t = t_1 + t_2 + t_3 + t_4 + t_5 = 120 \text{ sn}$$

Äquivalentes Drehmoment;

$$T_e = \left( \frac{30 \times 48^{6.6} + \dots + 43 \times 5^{6.6}}{120} \right)^{\frac{1}{6.6}}$$
$$= 39,2 \text{ kNm}$$

50% von äquivalenten Drehmoment;

$$0.5 \times T_e = 19.6 \text{ kNm}$$

Drehmomentanteile müssen größer als dieser Wert sein;

$$T_4, T_5 < 0.5 \times T_e$$

Wir wiederholen die Berechnung nochmals ohne die kleine Drehmomentanteile;

$$t' = t - t_4 - t_5 = 120 - 43 - 10 = 67 \text{ s}$$

$$T_e = \left( \frac{30 \times 48^{6.6} + \dots + 15 \times 28^{6.6}}{67} \right)^{\frac{1}{6.6}}$$
$$= 42,9 \text{ kNm}$$

Mit Hilfe von äquivalenten Drehmoment und konstanter Drehzahl berechnet man die äquivalente Leistung ;

$$P_{eq} = \frac{T_e \times n}{9550} = \frac{42,9 \times 1000 \times 50}{9550} \cong 225 \text{ kW}$$

Nach Bestimmung der äquivalente Leistung und konstanter Drehzahl, erfolgt die Getriebeauslegung dann wie die Getriebeauswahl gemäß dem in diesem Katalog beschriebenen Verfahren für konstante Leistung.

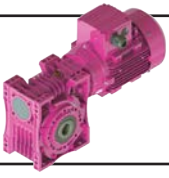

# Genel Bilgiler

## General Information

### Einführung



#### Redüktör Seçimi

Bir redüktör seçiminde aşağıdaki yol izlenmelidir.

1. Çalışma şartlarına bağlı olarak servis faktörünü (fs) belirleyiniz. (Servis Faktörü Sayfa 19).
2. Makinanız için gerekli olan momenti belirleyiniz  $M_2$  (redüktör gerekli çıkış momentini).
3. Makinanızın devrini belirleyiniz  $n_2$  (redüktör gerekli çıkış devri).
4. Makinanızın güç ihtiyacını (Redüktör çıkış gücünü) "P<sub>2</sub>" hesaplayınız.

$$P_2 = \frac{M_2 \times n_2}{9550}$$

5. Redüktör ile makina arasında kullanılan bağlantı elemanına göre radyal yükü hesaplayınız. (Sayfa 22). Yukarıdaki verilere uygun olarak çıkış devri, değerlerine uyan servis faktörü ve radyal yükü bulduğunuzdan daha yüksek veya eşit olan redüktörü, güç-devir seçim tablolarından seçiniz. Helisel tip redüktörlerde verim yüksek olduğundan çıkış gücü verilmemiştir. Hesapladığınız güç değerini giriş gücü olarak kabul edip seçiminizi yapınız. Tablolarda verilen  $M_2$  çıkış momentinin hesapladığınız  $M_2$  den büyük olmasına dikkat ediniz. Eğer seçilen redüktörünki daha ufak ise bir üst motor gücüne geçiniz.

#### Örnek

##### 1. Makina Cinsi:

Lastik bantlı konveyör , dökme yük taşıyor.

##### 2. Makina için gerekli moment:

Makina için hesaplanan moment  $M_2 = 470 \text{ Nm}$ .

##### 3. Makina gerekli çıkış devri:

$n_2 = 54 \text{ dev/dak}$ .

##### 4. Günlük çalışma süresi:

16 saat.

##### 5. Saatte start sayısı:

Saatte 1 start

##### 6. Makina ile bağlantı şekli:

Zincir dişli ( çap -130 mm )

- Yük sınıflandırma tablosundan yük sınıfı M olarak seçilir (sayfa 20-21)

- Günlük çalışma süresi 16 saat Saatte start sayısı 1 ve yük sınıfı M'ye tekabül eden servis faktörü tablosundan, servis faktörü için fs= 1.3 değeri bulunur.(sayfa 19)

- Makinanızın güç ihtiyacı (Redüktör Çıkış Gücü) :

$$P_2 = \frac{M_2 \times n_2}{9550} = \frac{470 \times 50}{9550} = 2,46 \text{ kW}$$

#### Gearbox Selection

For the correct selection of the appropriate gear units follow this steps.

1. Determine service factor (fs) on the basis of running conditions (Page 19).
2. Determine the required Torque  $M_2$  (required output torque of gearbox) for the driven machine.
3. Determine required speed (output speed of gearbox) for the driven machine.
4. Calculate the required power for your machine (Calculate power "P<sub>2</sub>" required at output side of gear reducer using the formula);

$$P_2 = \frac{M_2 \times n_2}{9550}$$

5. Calculate overhung load required at output shaft according to type of connection between gear unit and machine (Refer to directions and values given on page 22). After determining the above mentioned values, the gear reducer which corresponds to our requirements can be selected from the performance tables (the service factor and the permissible overhung load should be less than or equal to our requirement). For Helical gears the output power is not given on the performance tables because they have high efficiency and the output power can be taken as input power. The output torque should be checked if it meets to our requirements. If the output torque is low, search for a higher input power gearbox.

#### Example:

##### 1. Machine Type:

Belt Conveyor (Bulk Load)

##### 2. Required Torque:

Required Torque calculated for the driven machine is  $M_2=470 \text{ Nm}$ .

##### 3. Required speed:

$n_2 = 50 \text{ rpm}$

##### 4. Running time:

16 hours per day

##### 5. Frequency of starting:

1 start per hour

##### 6. Connection type between gear reducer

Chain drive (output dimension-130 mm)

- From the load classification table (on page 20-21), the load class M can be selected for the known application.

- The service factor can be selected as fs =1,3 from the service factor table (page 19) by taking into consideration 16 hours running time, one start per hour, and load class M.

-Required power for your machine(Power at output side of gear reducer) :

$$P_2 = \frac{M_2 \times n_2}{9550} = \frac{470 \times 50}{9550} = 2,46 \text{ kW}$$

#### Getriebeauswahl

Für die korrekte Auswahl des Antriebes;

1. Den Betriebsfaktor(fs) in Abhängigkeit von den Betriebsbedingungen bestimmen.(Bezug auf Seite 19).
2. Die erforderte Drehmoment  $M_2$  für die angetriebene Maschine (Abtriebsdrehmoment für die Getriebe) bestimmen.
3. Erforderte Drehzahl bestimmen (Abtriebsdrehzahl für die Getriebe).
4. Berechnen der erforderte Leistung der angetriebene Maschine (Die an der Abtriebswelle erforderte Leistung "P<sub>2</sub>") mit der unten angegebenen Formel.

$$P_2 = \frac{M_2 \times n_2}{9550}$$

5. Die an der Getriebeabtriebswelle erforderte Querkraft in Abhängigkeit von Antriebsselement bestimmen (Bezug auf Seite 22). Nach Bestimmen der oben angegebenen Werte, die passende Getriebe kann von den angegebenen Leistungstabellen entnommen werden. Dabei soll darauf geachtet werden, dass der Betriebsfaktor und Querkraft stets unterhalb von angegebenen Werten liegt. Weil Stirnradgetrieben einen hohen Wirkungsgrad haben, sind die Abtriebsleistungen für Stirnradgetrieben nicht angegeben. Bei dieser Getrieben die erforderte Leistung kann als Antriebsleistung benutzt werden. Achten sie darauf, dass der Abtriebsmoment größer als die erforderte Drehmoment ist.

#### Beispiel:

##### 1. Maschinentyp:

Gurtbandförderer (Schüttgut)

##### 2. Erforderte Drehmoment:

Für die Maschine berechnete Drehmoment  $M_2 = 470 \text{ Nm}$ .

##### 3. Erforderte Drehzahl:

$n_2 = 50 \text{ upm}$

##### 4. Betriebsdauer:

16 stunden pro Tag

##### 5. Schalthäufigkeit:

1 Start pro Stunde

##### 6. Antriebsselement für Verbindung mit Getriebe:

Kettentrieb(Durchmesser- 130 mm)

- Von den Belastungsart Tabellen(Seite 20-21) nimmt man Belastungsart M

- Für den Schaltungszahl 1 und die Laufzeit 16 und für den passenden Belastungsart erhält man Betriebsfaktor fs =1,3 von Tabelle auf Seite 19.

- Erforderte Leistung der angetriebe Maschine (Die an der Getriebeabtriebswelle erforderte Leistung)

$$P_2 = \frac{M_2 \times n_2}{9550} = \frac{470 \times 50}{9550} = 2,46 \text{ kW}$$

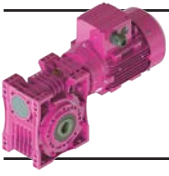

## Genel Bilgiler General Information Einführung



- Zincir dişli uygulaması için (Sayfa 23) Fq değeri;

$$Fq = \frac{2100 \times M_2}{D} = \frac{2100 \times 400}{130} = 6461,53 \text{ N}$$

- Ortaya çıkan redüktör ihtiyacı

$$\begin{aligned} P_2 &\geq 2,46 \text{ kW} \\ M_2 &\geq 400 \text{ Nm} \\ fs &\geq 1,3 \\ n_2 &\approx 50 \text{ d/dak} \\ Fq &\geq 6461,53 \text{ N} \end{aligned}$$

Güç ve devir sayfalarından,

**EV125-3E100L/4D** seçilir (Sayfa 65).

$$\begin{aligned} P_2 &= 3 \text{ kW} > 2,46 \text{ kW} \\ M_2 &= 433 \text{ Nm} > 400 \text{ Nm} \\ fs &= 1,7 \\ n_2 &= 56 \text{ d/dak} \\ fq &= 6461,53 \text{ Nm} < 8498 \text{ Nm} \\ i &= 26 \end{aligned}$$

- For chain drive application the requested overhang load can be calculated from (page 23).;

$$Fq = \frac{2100 \times M_2}{D} = \frac{2100 \times 400}{130} = 6461,53 \text{ N}$$

- The required gearbox is as follows:

$$\begin{aligned} P_2 &\geq 2,46 \text{ kW} \\ M_2 &\geq 400 \text{ Nm} \\ fs &\geq 1,3 \\ n_2 &\approx 50 \text{ rpm} \\ Fq &\geq 6461,53 \text{ N} \end{aligned}$$

From the performance table,

**EV125-3E100L/4D** selected (Page 65).

$$\begin{aligned} P_2 &= 3 \text{ kW} > 2,46 \text{ kW} \\ M_2 &= 433 \text{ Nm} > 400 \text{ Nm} \\ fs &= 1,7 \\ n_2 &= 56 \text{ rpm} \\ fq &= 6461,53 \text{ Nm} < 8498 \text{ Nm} \\ i &= 26 \end{aligned}$$

- Für Kettentrieb die erforderte Querkraft (seite 23);

$$Fq = \frac{2100 \times M_2}{D} = \frac{2100 \times 400}{130} = 6461,53 \text{ N}$$

- Von den oben angegebenen Berechnungen die erforderte Getriebe ist wie folgt;

$$\begin{aligned} P_2 &\geq 2,46 \text{ kW} \\ M_2 &\geq 400 \text{ Nm} \\ fs &\geq 1,3 \\ n_2 &\approx 50 \text{ U/min} \\ Fq &\geq 6461,53 \text{ N} \end{aligned}$$

Von der Leistung- Drehzahltable ,

wurde **EV125-3E100L/4D** gewählt (Seite 65).

$$\begin{aligned} P_2 &= 3 \text{ kW} > 2,46 \text{ kW} \\ M_2 &= 433 \text{ Nm} > 400 \text{ Nm} \\ fs &= 1,7 \\ n_2 &= 56 \text{ u/min} \\ fq &= 6461,53 \text{ Nm} < 8498 \text{ Nm} \\ i &= 26 \end{aligned}$$

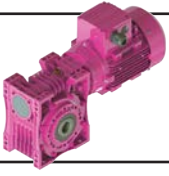

# Genel Bilgiler

## General Information

### Einführung



### Redüktör Seçim Formu

Kullanıldığı Sektör.....  
Kullanıldığı Yer.....  
Gerekli Ortalama Devir.....d/dak

#### Makina ihtiyaç gücü:

-Normal..... kW  
-En çok..... kW  
-En az..... kW

#### Tahrik Şekli:

AC Motor [ ]  
AC Motor + Invertör [ ]  
DC Motor [ ]  
Hidrolik Motor [ ]  
1-3 silindirli içten yanmalı [ ]  
2-4 silindirli içten yanmalı [ ]

#### Motor Bağlantı Şekli (Elektrik Motorları):

IEC B5/B14 Flanşlı [ ]  
NEMA Flanşlı [ ]  
Motorsuz Giriş Mili [ ]

IEC veya NEMA flanş kodu. ....

#### Motor Gücü:

-Nominal..... kW

#### Motor Devri:

-Normal..... d/dak  
-En çok..... d/dak  
-En az..... d/dak

#### Motor Torku:

-Normal..... Nm  
-En çok..... Nm  
-En az..... Nm

#### Dönüş şekli:

saat yönü [ ] saat yönüne ters [ ] değişken [ ]

#### Günlük çalışma süresi:

<4 [ ] 4-8 [ ] 8-16 [ ] >16 [ ]

#### Saatdeki start sayısı:

0-50 [ ] 50-100 [ ] 100-200 [ ]  
200-300 [ ] 300-500 [ ] 500-700 [ ]  
700-1000 [ ] >1000 [ ]

Motor Redüktör Arası Tahvil Oranı.....

Kalkış için gerekli moment.....Nm

#### Saatdeki pik moment adedi:

1-5 [ ] 6-30 [ ] 31-100 [ ] >100 [ ]

#### Bir çevrimde aktif çalışma oranı (ED):

%100 [ ] %80 [ ] %60 [ ] 40% [ ] %20 [ ]

#### Deniz seviyesinden yükseklik:

<1000 [ ] <2000 [ ] <3000 [ ]  
<4000 [ ] <5000 [ ]

#### Montaj yeri:

Küçük kapalı oda (w<1m/sn) [ ]  
Kapalı oda (w<3m/sn) [ ]  
Büyük oda ve holler (w>=3m/sn) [ ]  
Tamamen açık ortam [ ]

#### Çevre Şartları:

Normal [ ] Tozlu [ ] Nemli [ ]  
Korozif [ ] Kuru [ ]

#### Çevre Sıcaklığı:

Ortalama..... °C  
En Yüksek..... °C  
En Düşük..... °C

#### Kilit İhtiyacı:

Var [ ] Yok [ ]

#### Redüktör Giriş Opsiyonu:

R.[ ] V.[ ] N.[ ] T.[ ]

#### Redüktör Çıkış Opsiyonu:

00 [ ] 01 [ ] 02 [ ] 03 [ ] 04 [ ] 05 [ ] 08 [ ]

#### Montaj Pozisyonu:

M1 [ ] M2 [ ] M3 [ ] M4 [ ] M5 [ ] M6 [ ]

#### Giriş mili bağlantı şekli:

Elastik kaplin [ ]  
Fıçı tipi kaplin [ ]  
Rijit kaplin [ ]  
Hidrolik Kaplin [ ]  
Kayış kasnak [ ]  
Zincir dişli [ ]  
Pinyon dişli [ ]  
Bağlantı elemanı çapı.....mm  
Radyal yükü.....N  
Radyal yük "u" mesafesi.....mm  
Aksiyal yükü (mile doğru +).....N

#### Çıkış mili bağlantı şekli:

Elastik kaplin [ ]  
Fıçı tipi kaplin [ ]  
Rijit kaplin [ ]  
Kayış kasnak [ ]  
Zincir dişli [ ]  
Pinyon dişli [ ]  
Delik milli tork kolu [ ]  
Sıkma bilezikli tork kolu [ ]  
Bağlantı elemanı çapı.....mm  
Radyal yükü.....N  
Radyal yük "u" mesafesi.....mm  
Aksiyal yükü (mile doğru +).....N

#### Çıkış Mili Özelliği:

Dolu Mil Kamalı [ ]  
Dolu Mil Kamasız [ ]  
Delik Milli [ ]  
Özel Mil [ ]

#### Giriş Mili Özelliği:

Kamalı [ ]  
Kamasız düz mil [ ]  
Özel Mil [ ]  
Tork kolu [ ] Var [ ] Yok

#### Elektrik Gerilimi:

AC-Monofaze [ ] AC-Trifaze [ ] DC [ ]  
Voltaj.....Volt  
Frekans.....Hz

#### Koruma Sınıfı:

IP55 [ ] IP65 [ ] Exproof [ ]  
Diğer IP.....

#### Ekler:

Yük diyagramı [ ]  
Proje [ ]  
İstenen ana boyutlar [ ]  
Teknik veriler [ ]

#### Diğer Notlar:

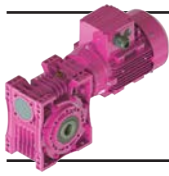

# Genel Bilgiler

## General Information

### Einführung



#### Gearbox Selection Form

Field of Industry.....  
 Application.....  
 Required Average Speed..... rpm

#### Required Power on Driven Machine:

-Normal..... kW  
 -Maximum..... kW  
 -Minimum..... kW

#### Driving Machine:

AC Motor [ ]  
 AC Motor + Inverter [ ]  
 DC Motor [ ]  
 Hydraulic Motor [ ]  
 Piston Engine with 1-3 cylinder [ ]  
 Piston Engine with 4-24 cylinder [ ]

#### Motor Connection Type (Electric Motors):

IEC B5/B14 Flange [ ]  
 NEMA Flange [ ]  
 Solid Input Shaft Without Motor [ ]

IEC or NEMA Flange Code.....

#### Motor Power:

-Nominal..... kW

#### Motor Speed:

-Normal..... rpm  
 -Maximum..... rpm  
 -Minimum..... rpm

#### Motor Torque:

-Normal..... Nm  
 -Maximum..... Nm  
 -Minimum..... Nm

#### Direction of Rotation:

cw [ ] ccw [ ] variable [ ]

#### Working hours per day:

<4 [ ] 4-8 [ ] 8-16 [ ] >16 [ ]

#### Startings per cycle:

0-50 [ ] 50-100 [ ] 100-200 [ ]  
 200-300 [ ] 300-500 [ ] 500-700 [ ]  
 700-1000 [ ] >1000 [ ]

Transmission ratio between motor and gear unit.....

Required Starting Torque.....Nm

#### Peak torques per hour:

1-5 [ ] 6-30 [ ] 31-100 [ ] >100 [ ]

#### Effective working time in a cycle (ED):

%100 [ ] %80 [ ] %60 [ ] 40% [ ]  
 20% [ ]

#### Altitude:

<1000 [ ] <2000 [ ] <3000 [ ]  
 <4000 [ ] <5000 [ ]

#### Mounting Place:

Small closed room (w<1m/sn) [ ]  
 Closed room (w<3m/sn) [ ]  
 Big rooms and halls (w>=3m/sn) [ ]  
 Outdoor [ ]

#### Ambient Conditions:

Normal [ ] Dusty [ ] Humid [ ]  
 Corrosive [ ] Dry [ ]

#### Ambient Temperature:

Average.....°C  
 Maximum.....°C  
 Minimum.....°C

#### Backstop Required:

Yes [ ] No [ ]

#### Gearbox input options:

V.[ ] N.[ ] T.[ ]

#### Gearbox output options:

00 [ ] 01 [ ] 02 [ ] 03 [ ] 04 [ ] 05 [ ] 08 [ ]

#### Mounting Position:

M1 [ ] M2 [ ] M3 [ ] M4 [ ] M5 [ ] M6 [ ]

#### Input Shaft Connection Type:

Elastic Coupling [ ]  
 Barrel Type Coupling [ ]  
 Hydraulic Coupling [ ]  
 Rigid Flange Coupling [ ]  
 Pulley [ ]  
 Chain Sprocket [ ]  
 Pinion [ ]  
 Diameter of Connection element.....mm  
 Radial Load.....N  
 "u" Distance of Radial Load.....mm  
 Axial Load (Towards Shaft) .....N

#### Output Shaft Connection Type:

Elastic Coupling [ ]  
 Barrel Type Coupling [ ]  
 Rigid Flange Coupling [ ]  
 Pulley [ ]  
 Chain Sprocket [ ]  
 Pinion [ ]  
 Hollow Shaft with Torque Arm [ ]  
 Schrink disc with Torque Arm [ ]  
 Diameter of Connection Element.....mm  
 Radial Load.....N  
 "u" Distance of Radial Load.....mm  
 Axial Load (Towards Shaft) .....N

#### Gearbox assembled by:

Foot [ ] Flange [ ] Torque Arm [ ]

#### Output Shaft Specification:

Solid Shaft with Keyway [ ]  
 Solid Shaft without Keyway [ ]  
 Hollow Shaft [ ]  
 Special Shaft [ ]

#### Input Shaft Specification:

Solid Shaft with Keyway [ ]  
 Solid Shaft without Keyway [ ]  
 Special Shaft [ ]  
 Torque arm required Yes [ ] No [ ]

#### Electrical Supply:

AC-1 Phase [ ] AC-3 Phase [ ] DC [ ]  
 Voltage.....Volt  
 Frequency..... Hz

#### Protection Class:

IP55 [ ] IP65 [ ] Exproof [ ]  
 Other IP.....

#### Attachments:

Load Diagram [ ]  
 Project [ ]  
 Required Dimensions [ ]  
 Technical Specifications [ ]

#### Notes:



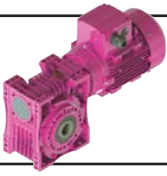

# Genel Bilgiler

## General Information

### Einführung



#### Formular für Getriebeauswahl

Industriebereich.....  
 Anwendung.....  
 Erforderliche Drehzahl.....U/min

#### Erforderliche Leistung für die Maschine:

-Normal.....kW  
 -Minimal.....kW  
 -Maximal.....kW

#### Antriebsmaschine:

AC Motor [ ]  
 AC Motor mit Frequenzumrichter [ ]  
 DC Motor [ ]  
 Hydromotor [ ]  
 Kolbenmaschinen mit 1-3 Zylinder [ ]  
 Kolbenmaschinen mit 2-4 Zylinder [ ]

#### Motorverbindungsart (Elektromotoren):

IEC B5/B14 Flansch [ ]  
 NEMA Flansch [ ]  
 Antriebsvollwelle ohne Motor [ ]

IEC oder NEMA Flanschcode.....

#### Motorleistung:

-Nominal.....kW

#### Motordrehzahl:

-Normal.....U/min  
 -Maximal.....U/min  
 -Minimal.....U/min

#### Motordrehmoment:

-Normal.....Nm  
 -Maximal.....Nm  
 -Minimal.....Nm

#### Drehrichtung:

in Uhrzeigersinn [ ] gegen Uhrzeigersinn [ ]  
 veränderlich [ ]

#### Betriebsdauer in Stunden pro Tag:

<4 [ ] 4-8 [ ] 8-16 [ ] >16 [ ]

#### Anzahl der Anläufe pro Stunde:

0-50 [ ] 50-100 [ ] 100-200 [ ]  
 200-300 [ ] 300-500 [ ] 500-700 [ ]  
 700-1000 [ ] >1000 [ ]

Übersetzung zwischen Motor und Antriebswelle.....

Erforderliches Anlaufmoment.....Nm

#### Häufigkeit von Lastspitzen pro Stunde:

1-5 [ ] 6-30 [ ] 31-100 [ ] >100 [ ]

#### Einschaltdauer je Stunde (ED):

%100 [ ] %80 [ ] %60 [ ] 40% [ ] %20 [ ]

#### Höhenlage über Meeresspiegel (m):

<1000 [ ] <2000 [ ] <3000 [ ]  
 <4000 [ ] <5000 [ ]

#### Betriebsort:

Kleine geschlossene Räume (w<1m/sn) [ ]  
 Geschlossene Räume (w<3m/sn) [ ]  
 Große Räume und Hallen (w>=3m/sn) [ ]  
 im Freien [ ]

#### Umgebungsbedingungen:

Normal [ ] Staubig [ ] Feucht [ ]  
 Korrodierend [ ] Trocken [ ] Verklebend [ ]

#### Umgebungstemperatur:

Mittelwert.....°C  
 Maximal.....°C  
 Minimal.....°C

#### Rücklaufsperre erforderlich:

Ja [ ] Nein [ ]

#### Getriebeeingangsvarianten:

V.[ ] N.[ ] T.[ ]

#### Getriebeausgangsvarianten:

00 [ ] 01 [ ] 02 [ ] 03 [ ] 04 [ ] 05 [ ] 08 [ ]

#### Montageposition:

M1 [ ] M2 [ ] M3 [ ] M4 [ ] M5 [ ] M6 [ ]

#### Antriebswellenanschluss:

Elastische Kupplung [ ]  
 Trommelkupplung [ ]  
 Hydrokupplung [ ]  
 Starre Flanschkupplung [ ]  
 Riementrieb [ ]  
 Kettenrad [ ]  
 Ritzel [ ]  
 Durchmesser von Anschlusselement.....mm  
 Querkraft.....N  
 "u" Abstand von der Wellenschulter.....mm  
 Axialkraft (in Richtung der Welle +) .....N

#### Abtriebswellenanschluss:

Elastische Kupplung [ ]  
 Trommelkupplung [ ]  
 Starre Flanschkupplung [ ]  
 Riementrieb [ ]  
 Kettenrad [ ]  
 Ritzel [ ]  
 Hohlwelle mit Drehmomentstütze [ ]  
 Schrumpfscheibe mit Drehmomentstütze [ ]  
 Durchmesser von Anschlusselement.....mm  
 Querkraft.....N  
 "u" Abstand von der Wellenschulter.....mm  
 Axialkraft (in Richtung der Welle +) .....N

#### Montage zur Getriebegehäuse mit:

Fuß [ ] Flansch [ ] Drehmomentstütze [ ]

#### Eigenschaften der Abtriebswelle:

Vollwelle mit Passfeder [ ]  
 Vollwelle ohne Passfeder [ ]  
 Hohlwelle [ ]  
 Sonderwelle [ ]

#### Eigenschaften der Antriebswelle:

Vollwelle mit Paßfeder [ ]  
 Vollwelle ohne Paßfeder [ ]  
 Sonderwelle [ ]  
 Drehmomentstütze erforderlich Ja [ ] Nein [ ]

#### Spannungsversorgung:

AC-1 phasig [ ] AC-3 phasig [ ] DC [ ]  
 Spannung.....Volt  
 Frequenz.....Hz

#### Schutzart:

IP55 [ ] IP65 [ ] Exproof [ ]  
 Andere IP.....

#### Anhang:

Lastdiagramm [ ]  
 Projekt [ ]  
 Erforderliche Abmessungen [ ]  
 Technische Spezifikationen [ ]

#### Andere Merkmale:

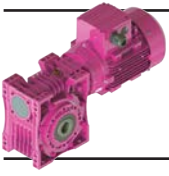

# Genel Bilgiler

## General Information

### Einführung



#### Yağlama

Redüktörlerin uzun ömürlü olması ve iyi performansla çalışabilmesi için, kullanılan yağın seçimi doğru olmalı ve belirtilen zamanlarda değişimleri yapılmalıdır.

Yağın seçiminde devir, çevre sıcaklığı, redüktör yağ sıcaklığı, çalışma koşulları ve yağ ömrü önem taşımaktadır. Redüktörler yağı doldurulmuş olarak sevkedilmektedir. Redüktörler uzun süre depolanacakları zaman veya çalışmaya başlanacağı zaman çalışma konumuna göre üstte kalan tapa sökülmesi ve redüktörün beraberinde verilen havalandırma tapası kullanılmalıdır. Bu redüktörün iç basıncından dolayı oluşacak yağ sızmalarını önleyecektir.

Redüktörlerde standart olarak kullanılan yağlar yan sayfadaki tabloda verilmiştir. Eğer Siparişte belirtilmezse Sonsuz Redüktörler M1 pozisyonuna göre yağ ile doldurulmuştur. Bu pozisyonlar dışındaki çalışma durumlarında tablolarda verilen yağ miktarlarına göre ilave veya eksiltme yapılmalıdır. Özel çalışma koşullarında firmamıza danışmanız tavsiye edilir.

Mineral yağlar her 10.000 çalışma saatinde, sentetik yağlar ise her 20.000 çalışma saatinde değiştirilmelidir. Ağır çevre koşullarında (ani ısı değişiklikleri, yüksek nemlilik v.b) yağ değiştirme periyotlarının kısaltılması tavsiye edilir. Mineral yağlar ile sentetik yağlar birbirine kesinlikle karıştırılmamalıdır. Değiştirme işlemi bir çalışma periyodunun hemen peşinden ve yağ sıcakken yapılmalıdır. Bu şekilde bir değiştirme, redüktör içindeki partiküllerin yağa karışmış olarak bulunmasından dolayı iyi bir temizleme ve yağın rahat boşalması neticesini verecektir.

Redüktörlerde kullanılan yağ tipi için etiketine bakınız.

#### Lubrication

*To work in perfect condition and to have long life for the gearbox the lubricant must be chosen correctly and changed in time.*

*In selection of oil it is important to consider speed, ambient temperature, gear box oil temperature, working conditions and the life required from the lubricant. All units are filled with lubricant before shipping. Before the gearbox is stored for a long time or before starting up, the top plug (according to the working position) must be removed and the extra given vent plug must be replaced. This prevents excessive pressure which causes oil leakages.*

*The lubricant in the standard line is given for standard fillings on the table below. If the mounting position not indicated on order Worm Geared gearboxes are filled with mounting position of M1. For other mounting positions please filling oil or draining oil refer to the table given on the next pages. For special working conditions please contact us.*

*The mineral lubricant should be changed after every 10.000 service hours and the synthetic lubricant should be changed after every 20.000 working hours. If the operation conditions are very heavy (e.g. high temperature differences, high humidity) shorter intervals between changes are recommended. Mineral and synthetic oils must not be mixed up. By changing the lubricant complete cleaning is advised. The oil change should be done after a working period. Because oil is hot in this condition and impurities are mixed with it the changing of oil will be done in best result and the oil will drain easily.*

*Please look at the label of your gear unit to check the filled oil type of gear unit.*

#### Schmierung

Um eine lange Lebensdauer zu gewährleisten muss der Schmierstoff richtig ausgewählt werden.

Für die richtige Ölauswahl müssen Drehzahl, Umgebungstemperatur, Belastungsart und Lebensdauer des Öls berücksichtigt werden. Die mitgelieferte Entlüftungsschraube ist vor Inbetriebnahme oder längeren Lagern gegen die Einfüllschraube auszutauschen, um einen Überdruck im Getriebe und damit eine Undichtigkeit des Getriebes zu vermeiden. Getriebe und Getriebemotoren sind bei Auslieferung betriebsfertig gefüllt.

Ohne besondere Bestellangaben werden die Getriebe grundsätzlich mit den auf der folgenden Seite in der grau unterlegten Spalte angegebenen Schmierstoffen gefüllt. Die fußbefestigten Getriebe sind befüllt für Bauform und die flanschbefestigten Getriebe für Bauform M1. Für andere Bauformen sind die auf der nächsten Seite angegebenen Füllmengen zu beachten.

Ein Schmierstoffwechsel sollte alle 10.000 Betriebsstunden durchgeführt werden. Für synthetische Produkte verdoppeln sich diese Fristen. Bei extremen Betriebsbedingungen, z.B. hohe Luftfeuchtigkeit, aggressiver Umgebung und hohen Temperatur-schwankungen sind kürzere Schmierstoffintervalle vorteilhaft. Es ist empfehlenswert, dem Schmierstoffwechsel mit einer gründlichen Reinigung des Getriebes zu verbinden. Synthetische und mineralische Schmierstoffe dürfen nicht miteinander vermischt werden. Das Ablassen des Öls soll unmittelbar nach dem Stillsetzen erfolgen, solange das Öl noch warm ist. In dieser Zustand ist das Öl mit den Schmutzpartikeln vermischt, so dass eine Entfernung des Altöls eine gute Reinigung garantiert.

Bitte im Getriebe verwendetes Öl von dem Namensschild ablesen.

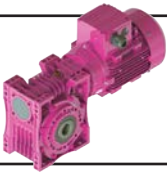

# Genel Bilgiler

## General Information

### Einführung



#### Yağ Tipleri / Oil Types / Schmierstoffe

Yağ Cinsi Lubricant Art des Schmierers	DIN 51517-3	Çevre Sıcaklığı (°C) Ambient Temperature (°C) Umgebungstemperatur (°C)		ISO VG	Aral	Beyond Petroleum	Castrol	Klüber Lubrication	Mobil	Shell	Total
		Daldırma Yağlama Dip Lubrication Tauchschmier.	Basınçlı Yağlama Forced Lubrication Druckschmier.								
Mineral Yağlar Mineral Oil Mineralöl	CLP	0 ... +50	-	680							
		-5 ... +45	-	460	Degol BG 680	Energol GR-XP 680	Alpha SP 680	Klüberoil GEM 1-680 N	Mobilgear 600 XP 680	Omala 680	Carter EP 680
		-10 ... +40	+15 ... +40	320	Degol BG 460	Energol GR-XP 460	Alpha SP 460	Klüberoil GEM 1-460 N	Mobilgear 600 XP 460	Omala F460	Carter EP 460
		-15 ... +30	+10 ... +30	220	Degol BG 320	Energol GR-XP 320	Alpha SP 320	Klüberoil GEM 1-320 N	Mobilgear 600 XP 320	Omala F320	Carter EP 320
		-20 ... +20	+5 ... +20	150	Degol BG 220	Energol GR-XP 220	Alpha SP 220	Klüberoil GEM 1-220 N	Mobilgear 600 XP 220	Omala F220	Carter EP 220
		-25 ... +10	+3 ... +10	100	Degol BG 150	Energol GR-XP 150	Alpha SP 150	Klüberoil GEM 1-150 N	Mobilgear 600 XP 150	Omala 150	Carter EP 150
Sentetik Yağlar Synthetic Oil Synthetisches Öl	CLP PG	-10 ... +60	-	680	Degol GS 680	Energol SG-XP 680	-	Klübersynth GH 6-680	Mobil Glygoyle 680	Tivela S 680	Carter SY 680
		-20 ... +50	-	460	Degol GS 460	Energol SG-XP 460	Aphasyn PG 460	Klübersynth GH 6-460	Mobil Glygoyle 460	Tivela S 460	Carter SY 460
		-25 ... +40	+5 ... +40	320	Degol GS 320	Energol SG-XP 320	Aphasyn PG 320	Klübersynth GH 6-320	Mobil Glygoyle 320	Tivela S 320	Carter SY 320
		-30 ... +30	0 ... +30	220	Degol GS 220	Energol SG-XP 220	Aphasyn PG 220	Klübersynth GH 6-220	Mobil Glygoyle 30	Tivela S 220	Carter SY 220
		-35 ... +20	-5 ... +20	150	Degol GS 150	Energol SG-XP 150	Aphasyn PG 150	Klübersynth GH 6-150	Mobil Glygoyle 22	Tivela S 150	Carter SY 150
		-40 ... +10	-8 ... +10	100	-	-	-	Klübersynth GH 6-100	Mobil Glygoyle 100	-	-
	CLP HC	-10 ... +60	-	680	-	-	-	Klübersynth GEM 4-680 N	Mobil SHC Gear 680	-	Carter SH 680
		-20 ... +50	-	460	Degol PAS 460	Energol EP-XF 460	Alphasyn T 460	Klübersynth GEM 4-460 N	Mobil SHC Gear 460	Omala HD 460	Carter SH 460
		-25 ... +40	+5 ... +40	320	Degol PAS 320	Energol EP-XF 320	Alphasyn T 320	Klübersynth GEM 4-320 N	Mobil SHC Gear 320	Omala HD 320	Carter SH 320
		-30 ... +30	0 ... +30	220	Degol PAS 220	Energol EP-XF 220	Alphasyn T 220	Klübersynth GEM 4-220 N	Mobil SHC Gear 220	Omala HD 220	Carter SH 220
		-35 ... +20	-5 ... +20	150	Degol PAS 150	Energol EP-XF 150	Alphasyn T 150	Klübersynth GEM 4-150 N	Mobil SHC Gear 150	Omala HD 150	Carter SH 150
		-40 ... +10	-8 ... +10	100	-	-	-	Klübersynth GEM 4-100 N	Mobil SHC 627	-	-
Gıda Uyumlu Yağ Food Grade Oil Lebensmittellöl	CLP NSF H1	-15 ... +25	+5 ... +25	220	-	-	Optileb GT 220	Klüberoil 4 UH1-220 N	Mobil SHC Cibus 220	Cassida Fluid GL-220	Nevastane SL 220
Çevre Dostu Yağ Biodegradable Oil Biologisch abbaubares Öl	CLP E	-25 ... +40	+5 ... +40	320	-	-	Tribol BioTop 1418-320	Klübersynth GEM 2-320	-	-	Carter Bio 320
Mineral Gresler [ -20 ... +120 °C Çalışma Sıcaklığı ] Mineral Grease [ -20 ... +120 °C Working Temperature ] Mineral-Fett [ -20 ... +120 °C Betriebstemperatur ]					Aralub HL3	Energol LS 3	Spheerol AP3	Centoplex 2 EP	Mobilux EP 3	Alvania RL3	Multis Complex EP 2
Sentetik Gresler [ -30 ... +100 °C Çalışma Sıcaklığı ] Synthetic Grease [ -30 ... +100 °C Working Temperature ] Synthetisches Fett [ -30 ... +100 °C Betriebstemperatur ]					-	Energol SY 2202	-	Petamo GHY 133 N	Mobiltemp SHC 100	Cassida RLS 2	Multis Complex SHD 220

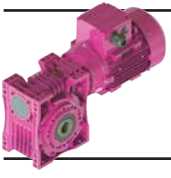

# Genel Bilgiler General Information Einführung



Montaj Pozisyonları / Mounting Positions / Bauformen

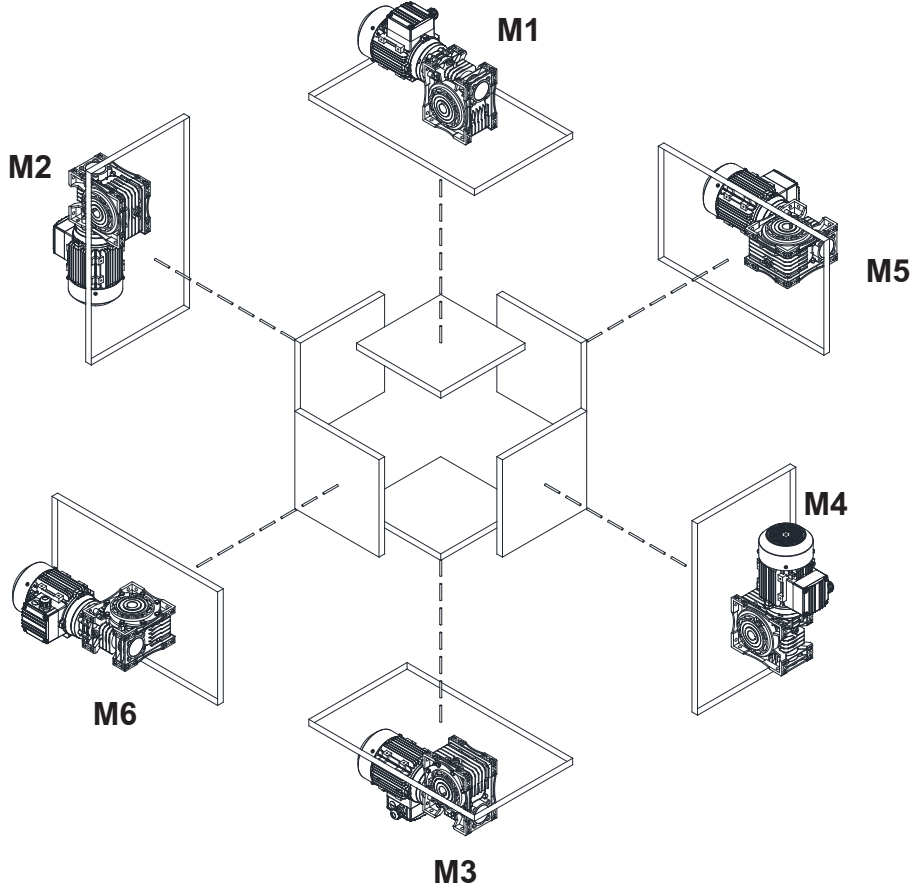

**M1....M6 'ya kadar belirtilen montaj pozisyonları redüktörün duruş yönü referans alınarak belirlenmiştir. Montaj yüzeyleri bağlayıcı değildir.**

*Figured mounting positions of M1 to M6 are determined as reference of directional position of the gearbox. Mounting surfaces are not binding.*

Dargestellte Montagepositionen M1 bis M6 wurden nach der Stehrichtung von Getriebe bestimmt. Montageoberflächen sind unverbindlich.

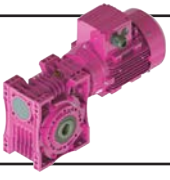

# Genel Bilgiler

## General Information

### Einführung



Yağ Miktarları (lt) / Oil Quantities (lt) / Ölmengen (liter)

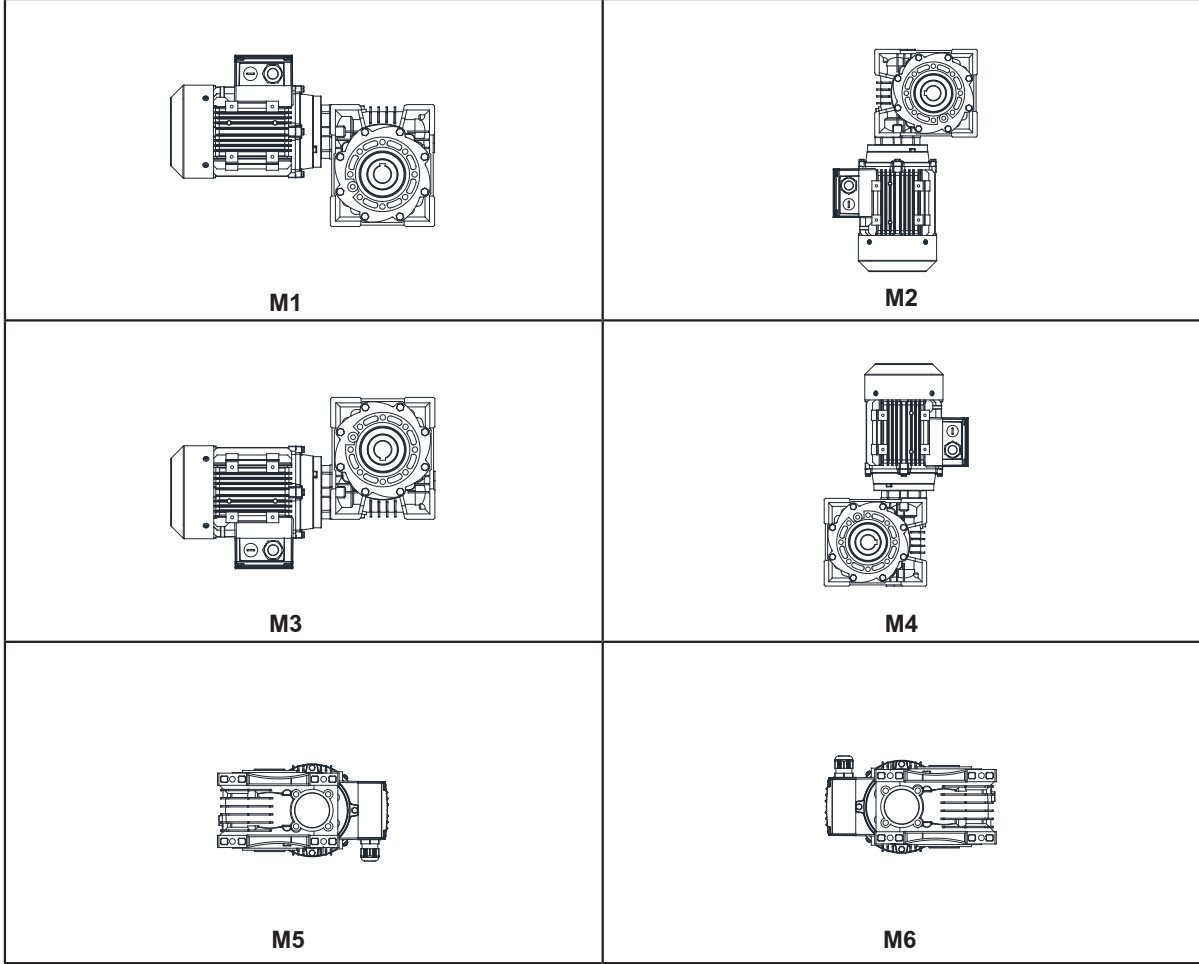

Yağ Miktarları (lt) / Oil Quantities (lt) / Ölmengen (liter)

Tip / Type / Typ	M1	M2	M3	M4	M5	M6
E.30	0,025	0,04	0,02	0,04	0,04	0,04
E.40	0,07	0,10	0,12	0,10	0,10	0,10
E.50	0,15	0,15	0,15	0,15	0,15	0,15
E.63	0,30	0,40	0,26	0,40	0,50	0,40
E.75	0,45	0,65	0,35	0,65	0,65	0,65
E.80	0,60	0,80	0,50	0,80	0,80	0,80
E.100	1,7	2,1	1,2	2,1	2,1	2,1
E.125	3,1	3,6	2,0	3,6	3,6	3,6

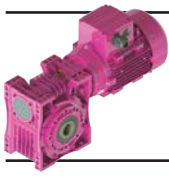

# Genel Bilgiler

## General Information

### Einführung



#### MOTORLAR

##### AC Motorlar

##### a- Genel Özellikler:

Basit konstrüksiyonlu, bakım gerektirmez, güvenilirliği yüksek ve uygun fiyatlı olmaları nedeni ile trifaze asenkron motorlar en çok kullanılan motor cinsidir. Bu motorların çalışma karakteristikleri moment-hız eğrisi ile belirlenir. Aşağıda bu karakteristik eğrisine bir örnek verilmiştir.

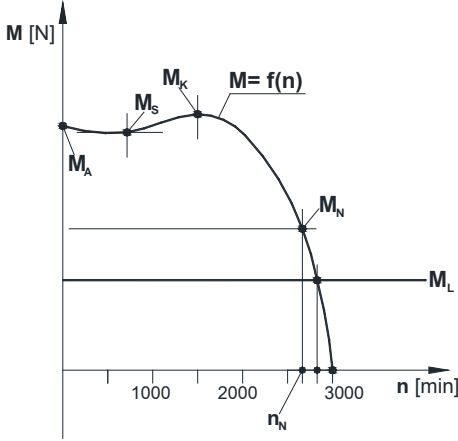

Motorun her start yapılmasında bu eğriye uygun hareket eder ve yük momentini  $M_L$  ile bu eğrinin çakıştığı noktada, motorun çalışma anındaki moment ve devirini verir.

Statorun manyetik alanı senkron hızla  $n_s$  döner. Kutuplar arasındaki faz kayması 3 fazlı motorlarda  $120^\circ$  'dir.

$$n_s = 120 \times \frac{f}{p_s}$$

f.....: şebeke frekansı [Hz]  
p\_s.....: statorun kutup sayısı

Rotorun değişken manyetik alanı rotorun statorun manyetik alanının dönüşü yönünde dönmeye başlamasını sağlar. Rotor bu hareketinde statorun manyetik alanını takip eder ama hiçbir zaman yakalayamaz. Rotor statorun manyetik alanının hızından yavaş döner. Rotorun bu hızına baz hız  $n_N$  denir. Yükün azalması rotorun hızının artmasını sağlar, aynı zamanda sapma azalmış olur. Sapma aşağıdaki gibi belirlenmiştir:

$$s = \frac{n_s - n_N}{n_s} \times 100$$

Sapmanın miktarına göre motorun nominal değerlerinde şu farklılıklar olabilir.

Sapma s .....:  $\pm 20\%$   
Kalkış Akımı.....:  $\pm 20\%$   
Kalkış Momenti.....:  $-15 / +25 \%$   
Kütle Atalet Momenti.....:  $\pm 10\%$   
Verim (37 kW'a kadar).....:  $-0,15 (1-\eta)$

#### MOTORS

##### AC Motors

##### a- General Specifications:

On account of its simple and maintenance free construction, good reliability and price, the three phase squirrel cage motor is one of the most frequently employed electric motors. The run up behavior of a three phase squirrel cage motor is described by the torque-speed characteristic curve. An example is shown below.

$M_A$ : Start moment / Starting torque / Anlaufmoment

$M_S$ : Demeraj moment / Pull-up torque / Anziehungsmoment

$M_K$ : Frenleme moment / Pull-out torque / Bremsmoment

$M_N$ : Motorun ilettiği moment / Motor rated torque / Treibmoment

$M_L$ : Yük moment / Load torque / Lastmoment

The motor follows this torque characteristics up to its stable operating point every time, when it is switched on. Operating point is that point, where the moment speed curve intersects with load torque  $M_L$  line.

The magnetic field in the stator rotates at a synchronous speed  $n_s$ . Phase shift of each pole is  $120^\circ$  at 3 phase motors.

$$n_s = 120 \times \frac{f}{p_s}$$

f.....: supply frequency [Hz]  
p\_s.....: number of stator poles

Because of the alternating magnetic field in the rotor, the rotor starts running in the same direction of the stator flux and tries to catch up with the rotating flux. The rotor never catches up the stator field. The rotor runs slower than the speed of the stator field. This speed is called the base speed  $n_N$ .

A decrease in load will cause the rotor to speed up or decrease slip. The slip is defined as follows:

$$s = \frac{n_s - n_N}{n_s} \times 100$$

According to the slip, the nominal values of the electric motor can alter as follows:

Slip s .....:  $\pm 20\%$   
Starting current .....:  $\pm 20\%$   
Starting torque .....:  $-15 / +25 \%$   
Moment of inertia.....:  $\pm 10\%$   
Efficiency (up to 37 kW).....:  $-0,15 (1-\eta)$

#### MOTOREN

##### Drehstrommotoren:

##### a- Allgemeine Eigenschaften

Wegen die wartungsarme und leichte Konstruktion, hohe Sicherheit bei Nutzung und günstige Preise werden die asynchrone Drehstrommotoren am meisten benutzt. Motoranlaufverhalten wird mit Moment-Drehzahl-Kurve charakterisiert. Ein Beispiel ist unten angegeben.

Der Drehstrommotor läuft diese Kurve bei jeder Anlauf, bis dem stabilen Betriebspunkt erreicht wird. Betriebspunkt ist der Zustand, bei dem die Moment-Drehzahl-Kurve sich mit der Linie von erforderlichen Moment  $M_L$  schneidet.

Magnetisches Feld von Stator dreht sich mit synchroner Geschwindigkeit  $n_s$ . Phasenverschiebung von den Polen ist  $120^\circ$  bei 3 phasigen Drehstrommotoren.

$$n_s = 120 \times \frac{f}{p_s}$$

f.....: Frequenz der Spannung [Hz]  
p\_s.....: Anzahl der Polen von Stator

Durch das magnetische Wechselfeld in den Rotor, beginnt der Rotor sich in der gleichen Richtung des Statorflusses zu drehen und versucht diese Bewegung aufzuholen. Der Rotor kann den Statorfeld nie aufholen. Die Rotorgeschwindigkeit nennt man Basisgeschwindigkeit  $n_N$ . Eine Abnahme der Belastung bewirkt, dass der Rotor sich beschleunigt und der Schlupf sich verringert. Der Schlupf wird wie folgt definiert:

$$s = \frac{n_s - n_N}{n_s} \times 100$$

Für die nominale Werte der Drehstrommotoren sind folgende Abweichungen zulässig:

Schlupf s .....:  $\pm 20\%$   
Anzugsstrom .....:  $\pm 20\%$   
Anzugsmoment .....:  $-15 / +25 \%$   
Massenträgheitsmoment .....:  $\pm 10\%$   
Wirkungsgrad (bis 37 kW).....:  $-0,15 (1-\eta)$

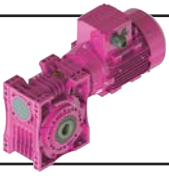

# Genel Bilgiler

## General Information

### Einführung



#### b- Çalışma Türleri

Katalogta verilen tüm redüktörlerin motorları S1 çalışma türüne uygun verilmektedir. Diğer çalışma türleri aşağıdaki tabloda gösterilmiştir.

#### b-Modes of Operation

All motors of the catalogue have been laid out for duty S1 (continuous operation). Other duty types are given on the following table.

#### b-Betriebsarten

Die im Katalog angeführten Motoren sind für Betriebsart S1 (Dauerbetrieb) ausgelegt. Andere Betriebsarten sind unten angegeben.

Çalışma Türü Operation Betriebsarten	Açıklama Explanation Erläuterung	Yük Grafiği Load Graphic Lastverläufe
S1	<b>Sabit yükte sürekli çalışma</b> <i>Continuous operation under constant load</i> Dauerbetrieb mit konstanter Belastung	
S2	<b>Sabit yükte kısa süreli çalışma</b> <i>Short-time duty under constant load</i> Kurzbetrieb mit konstanter Belastung	
S3	<b>Yolvermede sıcaklık artımı olmadan periyodik çalışma</b> <i>Periodic duty without influence of start-up on temperature</i> Aussetzbetrieb ohne Einfluß des Anlaufens auf die Temperatur	
S4	<b>Yolvermede sıcaklık artımı olan periyodik çalışma</b> <i>Periodic duty with influence of start up on temperature</i> Aussetzbetrieb mit Einfluß des Anlaufens auf die Temperatur	
S5	<b>Yolvermede ve frenlemede sıcaklık artımlı periyodik çalışma</b> <i>Periodic duty with influence of startup and braking on temp.</i> Aussetzbetrieb mit Einfluß des Anlaufens / Bremsung auf die Temp.	
S6	<b>Sürekli orta darbeli çalışma</b> <i>Continuous operation with intermittent loading</i> Durchlaufbetrieb mit Aussetzungsbelastung	
S7	<b>Elektriksel frenlemeli sürekli orta darbeli çalışma</b> <i>Continuous operation with intermittent loading and braking</i> Ununterbrochener Betrieb mit Anlauf und Bremsung	
S8	<b>Devir ve yük değişimli sürekli çalışma</b> <i>Continuous operation duty type with related load-speed changes</i> Ununterbrochener periodischer Betrieb mit Drehzahländerung	

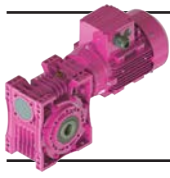

# Genel Bilgiler

## General Information

### Einführung



#### c- Koruma Sınıfı:

Yılmaz Redüktörde standart olarak IP54 (IEC 34-5) koruma sınıfı motorlar kullanılmaktadır. Diğer koruma sınıfları istendiğinde firmamıza danışınız.

#### d- İzolasyon Sınıfı:

Yılmaz Redüktörde kullanılan standart izolasyon sınıfı F (IEC 317-8) dir. İstek üzerine H sınıfı yapılabilmektedir.

#### e- Verim Sınıfları:

Üç fazlı az gerilim asenkron motorların verim sınıfı ölçümü IEC 60034-2-1:2007 normu ile belirlenmiştir. Yeni IE verim sınıfı 0,75 kW'tan 375 kW'a kadar güç aralığında çalışan AC motorlar için geçerlidir. EFF verim sınıfından farklı olarak IE verim sınıfı 6 kutup sayılı motorlar içinde kullanılabilir. Aşağıda verim sınıfları sıralanmıştır. Bölgeler dışında verim sınıfı zorunlulukları ülkelere görece farklılık gösterebilir. Lütfen firmamıza danışınız. Başka ürünlere entegre olmuş ve bu nedenle motorun veriminin bağımsız belirlenemediği sistemlerde (redüktör pompa gibi) verim sınıflandırması geçerli değildir.

#### c- Protection Class:

Yılmaz Redüktör uses IP54 (IEC 34-5) protection class electric motors for standard products. If different kind of protection class is requested please contact us.

#### d- Insulation Class:

Yılmaz Redüktör uses F (IEC 317-8) insulation class electric motors for standard products. H insulation class is available upon request.

#### e- Efficiency Classes:

The method for measuring the efficiency of low voltage three-phase asynchronous motors was revised with the new IEC 60034-2-1:2007 standard. The new IE classes is valid for AC Motors in power range from 0,75 to 375 kW. Unlike the EFF classes IE classes can be used for 6-pole AC motors. Below is the table of efficiency classes. The instructions for efficiency classes can differ from country to country. Please contact with us for more information. For the motors, which are fully integrated into a product (for example gear, pump) so their energy efficiency can not be recognized independently, the requirements of efficiency are not valid in Europe.

#### c- Schutzarten:

Yılmaz Redüktör Getriebemotoren werden serienmäßig mit Schutzart IP54 (IEC34-5) ausgeführt. Für andere Schutzarten bitte rückfragen.

#### d- Isolationsklasse:

Yılmaz Redüktör Getriebemotoren werden serienmäßig in Wärmeklasse F (IEC317-8) ausgeführt. H Wärmeklasse ist möglich auf Kundenwunsch.

#### e- Energieeffizienzklassen:

Die Methode für Messung der Effizienz von drei phasigen gering Spannung Asynchronmotoren hat neu mit IEC 60034-2-1:2007 Norm festgestellt. Die neue IE-Klassen gelten für alle Drehstrommotoren im Leistungsbereich von 0,75 bis 375 kW. Anders als EFF-Klassen die IE-Klassen können auch für 6-polige Drehstrommotoren verwendet werden. Unten steht die Tabelle der Effizienzklassen. Die Richtlinien für Effizienzklassen können sich je nach dem Land unterscheiden. Bitte mit unserem Firma Kontakt aufnehmen. Für die Motoren, die vollständig in ein Produkt (zum Beispiel Getriebe, Pumpe) eingebaut sind und deren Energieeffizienz nicht unabhängig von diesem Produkt erfasst werden kann, gelten in Europa die Anforderungen der Effizienzklassen nicht.

Verim Sınıfları Efficiency Classes Energieeffizienzklassen		4 Kutuplu Motor Verim Değeri Hesabı Calculating Efficiency Values of Motors with 4 Poles Berechnung der Wirkungsgrade von Elektromotoren mit 4 Polen	
IE1	EFF 2	<b>Standart Verim</b> Standart Efficiency Standarte Energieeffizienz	A=0,5234 B=-5,0499 C=17,4180 D=74,3171
IE2	EFF 1	<b>Yüksek Verim</b> High Efficiency Hohe Energieeffizienz	A=0,0278 B=-1,9247 C=10,4395 D=80,9761
IE3	-	<b>Premium Verim</b> Premium Efficiency Premium Energieeffizienz	A=0,0773 B=-1,8951 C=9,2984 D=83,7025
IE4	-	<b>Süper Premium Verim</b> Super Premium Efficiency Super Premium Energieeffizienz	-

$$\eta_{Mn} = A \times [\log_{10}(P_L)] + B \times [\log_{10}(P_L)]^2 + C \times \log_{10}(P_L) + D$$

$P_L$  :Anma Yüğü [kW] / Nominal Load [kW] / Nennlast [kW]

$\eta_{Mn}$  :Nominal verim / Nominal Efficiency / Sollwirkungsgrad

4 Kutuplu Motor Verim Değeri Efficiency Values of Motor with 4 poles Sollwirkungsgrad des Motors mit 4 Polen	Anma Yüğü [kW] Nominal Load [kW] Nennlast [kW]	Verim Sınıfı / Efficiency Class / Energieeffizienzklassen		
		IE1	IE2	IE3
	0,75	72,1 %	79,6 %	82,5 %
	1,5	77,2 %	82,8 %	85,3 %
	3	81,5 %	85,5 %	87,7 %
	7,5	86 %	88,7 %	90,4 %
	15	88,7 %	90,6 %	92,1 %
	22	89,9 %	91,6 %	93 %
	37	91,2 %	92,7 %	93,9 %
	45	91,7 %	93,1 %	94,2 %
	75	92,7 %	94 %	95 %
	90	93 %	94,2 %	95,2 %
	330	94 %	95,1 %	96 %



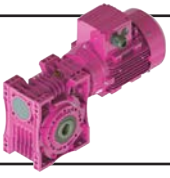

# Genel Bilgiler General Information Einführung



## f- AC Frekans İnvörtörler

Doğru Akımı (DC), alternatif akıma (AC) çeviren elektronik çeviricilere invörtör denilmektedir. AC motorlar için elektronik hız kontrol cihazları genellikle AC giriş akımını doğrultucu diyotlarla DC akıma çevirir ve daha sonra çevirici diyotlar vasıtasıyla bu akımı tekrar AC akıma çevirir. Doğrultucu diyotlar ile çevirici diyotlar arasındaki bağlantı DC-bağ olarak tanımlanmaktadır. DC kontrol cihazının (genellikle invörtör olarak isimlendirilir) elektriksel blok şeması aşağıda verilmiştir.

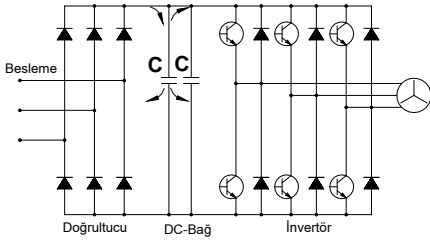

Tam dalga doğrultucuları besleyen üç faz besleme akımı DC-bağ kapasitörlerine iletilir. Kapasitörler voltajdaki dalgalanmaları azaltır ve kısa süreli ağdaki akım kesintilerinde enerji sağlar. Kapasitörlerdeki voltaj kontrolsüzdür ve gelen AC akımın pik akım değerlerine bağlıdır. DC akım tekrar AC akıma, Puls genişliği modülasyonu (PWM) kullanılarak çevrilir. İstenen dalga formu, sabit bir frekansta (Puls frekansında), çıkış transistörlerinin (İzole edilmiş geçit Bipolar transistörleri; IGBT 'ler) açılıp kapatılması ile oluşturulur. IGBT'lerin açma kapama zamanlarının değişimi ile istenen akım oluşturulabilir. Çıkış voltajı bir seri kare dalga pulslardır ve motor sargılarının indüktansı ile sinusoidal bir motor akımı oluşur. Puls genişliği modülasyonu aşağıda gösterilmiştir.

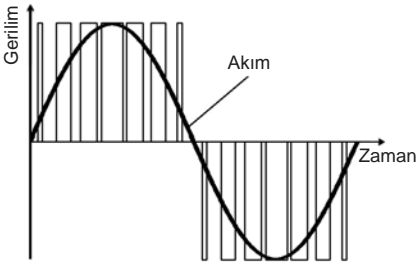

## f- AC Frequency Inverters

An electronic converter is a device which converts Direct Current (DC) to Alternating Current (AC) is known as an inverter. Electronic speed controllers for AC motors usually convert the AC supply to DC using a rectifier, and then convert it back to a variable frequency, variable voltage AC supply using an inverter bridge. The connection between the rectifier and inverter is called the DC link. The block diagram of a speed controller (often called an inverter) is shown below.

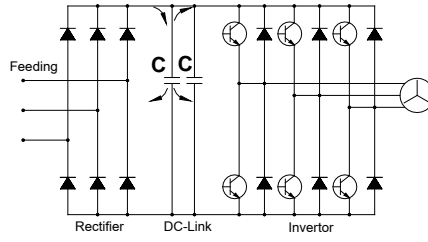

The three phase supply is fed into a full wave rectifier which supplies the DC link capacitors. The capacitors reduce the voltage ripple (especially on single supplies) and supply energy for short mains breaks. The voltage on the capacitors is uncontrolled and depends on the peak AC supply voltage. The DC voltage is converted back to AC using Pulse Width Modulation (PWM). The desired waveform is built up by switching the output transistors (Insulated Gate Bipolar Transistors; IGBTs) on and off at a fixed frequency (the switching frequency). By varying the on and off time of the IGBTs the desired current can be generated. The output voltage is still a series of square wave pulses and the inductance of the motor windings results in a sinusoidal motor current. Pulse Width Modulation is shown in the figure below.

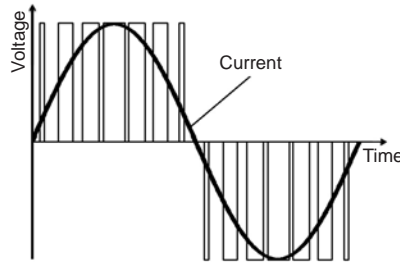

## f- AC Frequenz Umrichter

Ein elektronischer Wandler, der den Gleichstrom (DC) in Wechselstrom (AC) umwandelt, wird als Umrichter bezeichnet. Ein Frequenzumrichter benutzt einen ungesteuerten Eingangsgleichrichter, um die Netzspannung in Gleichspannung umzuwandeln. Diese wird dann in den Zwischenkreiskondensatoren gespeichert. An diesem Gleichspannungszwischenkreis ist ein Wechselrichter angeschlossen. Dieser Wechselrichter erzeugt am Ausgang eine variable Frequenz und eine variable Spannung. Der Anschluss zwischen dem Gleichrichter und dem Wechselrichter nennt man Gleichstromverbindung. Das Blockschaltbild von diesem System wurde unten dargestellt:

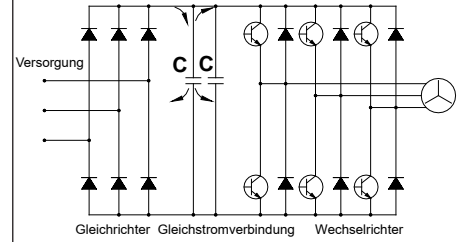

Auch bei dreiphasiger Versorgung wird die gleichrichtete Netzspannung den Zwischenkreiskondensatoren zugeführt. Die Kondensatoren reduzieren die Oberwelligkeit der Spannung (was besonders bei einphasiger Versorgung entscheidend ist) und liefern Energie, die kurze Unterbrechungen der Netzstromversorgung ermöglicht. Die Spannung der Kondensatoren ist vom Spitzenwert der Wechselspannung abhängig. Die Gleichspannung wird im Wechselrichter durch Pulsweitenmodulation (PWM) in Wechselspannung umgewandelt. Die gewünschte Wellenform wird durch Ein- und Ausschalten der Ausgangstransistoren (IGBT's Isolierte Gate Bipolar Transistoren) mit einer festen Frequenz (der Pulsfrequenz) erzeugt. Der gewünschte Strom kann durch die Variation der Ein- und Ausschaltzeit der Ausgangstransistoren generiert werden. Die Ausgangsspannung ist dadurch eine Reihe von Spannungsimpulsen, die in Verbindung mit der Induktivität der Motorspulen zu einem sinusförmigen Motorstrom führt. Die Pulsweitenmodulation wird wie folgt dargestellt

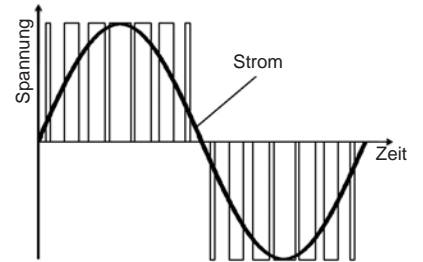

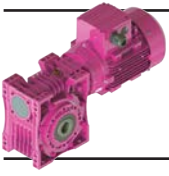

# Genel Bilgiler

## General Information

### Einführung



#### DC MOTORLAR

##### a- Genel Özellikler

DC motorlar, elektronik parçalardaki gelişmeler nedeni ile yeni uygulama alanları bulmuştur. Daha önce çok pahalı olan ve ekonomik olmayan kontrol sistemlerinin yerini ucuz ve kompakt güç kontrol üniteleri almıştır. Yol vermenin kontrol altına alınabildiği, tork ve akım izlenebilirliği, aşırı yüklenmeye karşı elektronik koruma sağlanabilmesi ve daha birçok pahalı olmayan uygulamalar DC motorlarını cazip kılmaya başlamıştır.

##### b- DC Motorların Çalışma İlkeleri

DC motorlar için DC çıkış veren bir doğrultucuya ihtiyaç vardır. Motor armatür sargıları, alan sargıları, komutasyon sargıları ve kompanse sargılar olmak üzere rotorda ve statorda bulunan sargılardan oluşur. Rotora voltaj ve akım karbon fırçalar ve komutator sargılarla ulaştırılır. Bu karbon fırçalar aşındığından DC motorlar belirli periyotlarla bakıma alınmalıdır. İyi kontrol edilebilir özelliklerinden dolayı DC motorlar otomasyon teknolojisinde sıkça kullanılmaktadır.

##### c- DC Motor Çeşitleri

Temel olarak Şönt (Shunt) ve seri sargılı DC motorlar bulunmaktadır. Bu sargıların çeşidine göre moment eğrisi değişmektedir.

##### d- DC Motorlarda Hız Kontrolü

Bu motorlarda devir değişimi DC voltajın değiştirilmesi ile yapılır. Şönt sarımlı DC motorların sıfır yük ile maximum yük arasındaki davranışı AC motorlara benzer. Devir artan yüklerle beraber düşer. Bu devir farkı ufak güçlü motorlarda büyük, büyük güçlü motorlarda ise ufaktır. Fakat bu hız farkı DC doğrultucu cihazda armatür voltajı ( $I \times R$ ) ile oynanarak kompanse edilebilir. Hassas hız kontrol gereksinimi olduğunda, tako jeneratörler kullanılabilir. DC motorların gücü aşağıdaki formülden hesaplanır;

$$P_g = U \times I = \frac{P_c}{\eta}$$

$P_g$  : Giriş gücü W  
 $P_c$  : Çıkış gücü W  
 $U$  : Armatür gerilimi V  
 $I$  : Armatür akımı A  
 $\eta$  : Motor verimi

#### DC MOTORS

##### a- General Specifications of DC Motors

*DC drive systems have found new possible applications with the development of the electronic components sector. What was previously extremely expensive and in some cases not economically feasible is nowadays realized by miniaturized power converter technology. Additional functions such as guided startup after a predetermined time, torque and current monitoring with electronic protection against overloading, and many inexpensive special applications have made DC drive systems more attractive.*

##### b- Operating principles of the DC Motors

*The DC motor requires, a converter with DC output. The motor includes windings, such as armature, field, commutation and compensation windings, which are arranged in the stator as well as on rotor. Voltage and current are supplied to the rotor via the carbon brushes and the commutator. The carbon brushes are wearing parts therefore a DC motor requires maintenance at service intervals. While its good control properties, the DC motor is an essential item in automation technology.*

##### c- Types of DC Motors

*Depending on the wiring of the exciting winding or field winding, two basically different variants are regards torque speed characteristics may be distinguished.*

##### d- Speed Control of DC motors

*In DC motors the speed is adjusted by altering the DC voltage. DC shunt wounded motors behave similar to three phase induction motors between no load operation and maximum load. The speed drops with increasing loading of the motor. This difference is greater in small motors and smaller in larger motors. The speed difference can be compensated in the DC converter device by adjusting ( $I \times R$ ). If great control accuracy is required, a speed control with measurement of the actual values by a tachogenerator can be used. The power of DC motor;*

$$P_g = U \times I = \frac{P_c}{\eta}$$

$P_g$  : Input Power W  
 $P_c$  : Output Power W  
 $U$  : Armature Voltage V  
 $I$  : Armature Current A  
 $\eta$  : Motor efficiency

#### DC MOTOREN

##### a- Eigenschaften von DC Motoren

Mit den Entwicklungen bei elektronischen Komponenten haben DC Motoren neue Anwendungsbereiche gefunden. Regelungssysteme, die früher sehr teuer und im manchen Anwendungsfällen ungünstig waren, sind jetzt kompakt und günstig. Bei den DC Motoren ist kontrolliertes Anlauf, Moment- und Stromüberwachung mit Überlastschutz möglich. Es gibt viele günstige Sonderanwendungen für diese Motoren. Wegen oben genannten Eigenschaften werden die DC Motoren immer mehr bei unterschiedlichen Anwendungen benutzt.

##### b- Funktionsprinzip der DC Motoren

Bei DC Motoren ist eine Kommutatorwicklung im Rotor angeordnet, während der magnetische Fluss vom Stator erzeugt wird. Dies kann wiederum mittels einer Erregerwicklung oder durch Permanentmagnete geschehen. Wie bei der Synchronmaschine wird durch das Erregerfeld in der Ankerwicklung eine Wechselfeldspannung, die bei der Gleichstrommaschine jedoch durch den mechanischen Kommutator und die darauf schleifenden Bürsten in eine Gleichspannung umgeformt wird, induziert.

##### c- Arten von DC Motoren

Es gibt zwei verschiedene Wicklungen, nämlich Shunt- und Serial-Wicklung. Das Drehmoment-Drehzahl-Verhältnis ist für beide Wicklungen unterschiedlich.

##### d- Drehzahl Kontrolle für DC Motoren

Drehzahl von DC Motoren kann man mit Steuerung der DC Spannung ändern. DC Motoren mit Shunt Wicklungen ist ähnlich zu drei phasen AC Motoren zwischen maximalen Last und ohne Last. Drehzahl wird mit der Last reduziert. Mit kleineren Motoren wird dieser Differenz höher mit größeren Motoren kleiner. Der Drehzahlunterschied kann geregelt werden mit ( $I \times R$ ) Veränderung. Wenn eine genaue Kontrolle gebraucht, soll ein Tachogenerator benutzt werden. Leistung des DC Motors;

$$P_g = U \times I = \frac{P_c}{\eta}$$

$P_g$  : Eingangsleistung W  
 $P_c$  : Ausgangsleistung W  
 $U$  : Ankerspannung V  
 $I$  : Ankerstrom A  
 $\eta$  : Wirkungsgrad des Motors

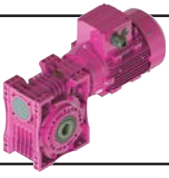

# Genel Bilgiler

## General Information

### Einführung



#### Elektromanyetik Frenler

Bu tip frenlerin iki sürtünme yüzeyi vardır. Fren torku, voltaj uygulanmadığı zaman yayların kuvveti ile oluşturulur. Fren elektromanyetik alanın oluşumu ile serbest kalır. Bobinin beslenmesi ile mıknatıslanan balata baskı pulu, elektromıknatısa doğru çekilir. Bu hareket yayları baskı altına alır ve rotor mili üzerine takılan çoklu kama üzerinde aksiyal yönde serbest hareket edebilen balata serbest kalır. Akım kesildiğinde yayların baskısıyla, balata baskı pulu fren balatasına doğru itilir ve bu hareket rotoru frenler.

#### Fren Çeşitleri

##### a) Soğutmasız tip frenler

Motor fanı çıkarılıp motor kapağı arkasına akuple edilerek kullanılan frenler; genellikle sıkça açılıp kapanmayan ve kısa zaman aralıklarında çalışan sistemlerde tercih edilir.

##### b) Soğutmalı tip frenler

Motor fanı çıkarılıp motor kapağı arkasına akuple edilen ve motorun mili uzatılarak fren ve motorun arkasına alınan fan sayesinde daimi bir hava sirkülasyonu sağlanarak kullanılan frenlerdir. Genellikle uzun süreli çalışan ve kapalı mekanlarda kullanılan sistemlerde tercih edilirler.

##### c) Manuel kol sistemli frenler

Çalışma sistemi olarak her iki fren tipinde de kullanılabilir (soğutmalı veya soğutmasız). Özel durumlarda (elektrik kesilmesi; mekanik problemler) üzerinde bulunan bir kol vasıtası ile sistemi yay baskısından kurtararak serbest kalmasını sağlayan frenlerdir. Genellikle manuel olarak sistemin açılması gereken yerlerde (otomatik giriş kapıları, dış cepe boyama asansörleri v.b.) tercih edilir.

#### Fren çalışma voltajları

Elektromanyetik frenler 230V AC veya 400V AC beslemeli olarak sipariş edilebilir. Frenler DC fren olmaları nedeni ile besleme ile fren bobini arasında fren tipine bağlı olarak, yarım dalga, tam dalga doğrultucular veya trafolar kullanılır. Özel olarak belirtilmedikçe 230V beslemeli ve yarım dalga doğrultuculu frenler kullanılmaktadır. Özel durumlar için YILMAZ Redüktöre danışınız.

##### a) 98V DC Frenler:

Motor klemens kutusundan alınan 230V'luk AC besleme yarım dalga doğrultucu ile 98V DC'ye dönüştürülür. Fren bobin DC voltajı etiketi üzerinde belirtilmiştir.

##### b) 198V DC Frenler

Motor klemens kutusundan alınan 400V'luk AC besleme, yarım dalga doğrultucu ile 198V DC'ye düşürülür. Fren bobininin DC voltajı etiket üzerinde belirtilmiştir.

##### c) 24V DC Frenler

Kullanılan fren momentinin büyüklüğüne göre besleme transformatörü seçilir. Şebekeden veya motorun klemens kutusundan alınan besleme voltajı transformatörde 29 V'a çevrilen gerilim tam dalga doğrultuculardan geçerek 24V DC'ye çevrilir ve fren bobini beslenir. İstenirse 24 VDC güç kaynağı da kullanılabilir.

#### Electromagnetic Brakes

*This type of brakes has two friction surfaces. Brake torque is generated by springs when no voltage is applied. The brake is electromagnetically released. On exciting the electromagnet means of the current, the armature plate is pulled towards the electromagnet itself, thrust loading the pressure spring and enabling the friction disc which is axially movable on the key, to turn freely. When current fails, the pressured springs drive the armature plate towards the disc, thus braking the motor shaft.*

#### Brake Types

##### a) Brakes without cooling

*This type of brakes are assembled on the back cover of the electric motor. There is no fan on the backside. This brake type is mostly preferred in short working times and short working cycles.*

##### b) Fan cooled brakes

*This type of brakes are assembled on the back cover of electric motor by removing the electric motor fan. A fan is coupled to the backside of the brake by extending the rotor shaft of the electric motor. Fan cooled brakes are preferred in long working times and closed places without airflow.*

##### c) Brakes with hand release

*This brakes can be released by help of an arm. It can be applied to both of the above mentioned brakes and used in special cases (fail of electric current, mechanical problems etc.) These brakes are mostly preferred if operation (releasing) without a current is needed (automatic controlled doors, gates, building wall painting elevators etc.).*

#### Working Voltages

*Electromagnetic brakes can be ordered with 230V AC or 400V AC supply voltage. The coil of brakes needs DC voltage and therefore depending on brake type a half wave, a full wave rectifier or transformer should be used between supply and coil voltage. As standard the brakes will be delivered with 230V supply voltage and half wave rectifier, if there is no special request. For special cases please contact YILMAZ Redüktör.*

##### a) 98V DC Brakes:

*230V AC supply voltage from the motor terminal box reduces to the 98V DC with half-wave rectifier. DC brake coil voltage is indicated on the label.*

##### b) 198V DC Brakes:

*400V AC supply voltage from the motor terminal box reduces to the 198V DC with half-wave rectifier. DC brake coil voltage indicated on the label.*

##### c) 24V DC Brakes

*The transformer's size is selected according to value of brake torque. The current is taken from the electric motor terminal box or from the electric panel and is transformed to 29V DC current. This current is transferred to 24V DC current with full-wave rectifier and supplies brake coil. Separated 24V DC Power supply usable.*

#### Elektromagnetische Bremsen

Die Bremse hat zwei Reibflächen und arbeitet nach dem Ruhestromprinzip. Im stromlosen Zustand wird das Bremsmoment durch den Druck der Feder erzeugt, während die Bremse beim Betrieb elektromagnetisch losgelassen wird. Durch die Erregung der Elektromagneten wird die Ankerscheibe zu den Elektromagneten gezogen und die Feder zusammengedrückt. Dadurch kann sich die Bremscheibe, die axial beweglich auf dem Mitnehmer angeordnet ist, frei drehen. Wird der Strom unterbrochen, drücken die Feder die Ankerscheibe gegen die Bremscheibe und halten die Motorwelle an.

#### Bremsearten:

##### a) Bremsen ohne Kühlung

Diese Bremsen sind für Kurzlaufzeiten geeignet. Die Lüfterhaube und Lüfter des Motors ist ausgebaut und die Bremse ist an dem Ende der Motorwelle befestigt.

##### b) Bremsen mit Kühlung

Diese Bremsen sind für lange Laufzeiten und kleine, abgedeckte Räume geeignet. Durch die Verlängerung der Motorwelle wurde Lüfter hinter dem Bremse und dem Motor verbunden. Somit wurde eine konstante Lüftung ermöglicht.

##### c) Bremsen mit Hebelarm

Diese Bremsenart kann mit oder ohne Kühlung verwendet werden. Diese Bremsen sind bei der speziellen Fälle, wie keine Spannung an der Leitung, mechanische Probleme usw., anwendbar. Die Bremse wird mit einem Hebelarm manuell betätigt. Diese Bremsen werden am meisten an den Stellen, wo die Lüftung ohne Spannung erfolgen soll, benutzt (automatische Türe, Wandaufzüge).

#### Betriebsspannungen

Elektromagnetische Bremsen können mit 230V AC oder 400V AC Versorgungsspannung bestellt werden. Die Wicklungen der Bremsen brauchen Gleichspannung und deswegen abhängig von Bremsenart zwischen Versorgungsspannung und Wicklungsspannung soll Halbwellen-, Vollweggleichrichter oder Transformator verwendet werden. Als Standard die Bremsen werden mit 230V Versorgungsspannung und Halbwellengleichrichter geliefert.

##### a) 98V DC Bremsen

230V AC Versorgungsspannung von Klemmenkasten wird auf die Wicklungsspannung 98V DC mit Halbwellengleichrichter reduziert. Wicklungsspannung ist auf dem Etikett angegeben.

##### b) 198V DC Bremsen

400V AC Versorgungsspannung von Klemmenkasten wird auf die Wicklungsspannung 198V DC mit Halbwellengleichrichter reduziert. Wicklungsspannung ist auf dem Etikett angegeben.

##### c) 24 V DC Bremsen

Die Spannung wird von den Klemmkasten des Motors oder Elektrischrank entnommen. Diese Spannung wird zuerst mittels Transformator zu 24 V reduziert. Danach wird diese Spannung mit Hilfe von Gleichrichter zu Gleichstromspannung umgewandelt. Die Größe des Transformators ist abhängig von der Größe des Bremsmoments. Es kann auch ein 24V DC Netzgerät benutzt werden.

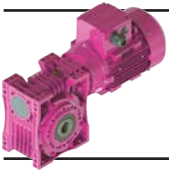

# Genel Bilgiler General Information Einführung



## d) Şok ikazlı trafolar

Büyük güçteki ve momentteki frenlerin manyetik doyuma ulaşmaları uzun zaman alır. Şok ikazlı trafolar frenin yay baskısını yenmede gecikmesini engellemek için kullanılır ve zaman rölesi yardımı ile çok kısa bir süre normal besleme voltajının iki katı ile (48V DC) beslenip sistemin ani açılmasını sağlar. Bu sayede gecikmeli açılmada ortaya çıkacak sürtünmeyi engellemeye yarayan bir trafo şeklindedir.

## Fren bağlantı şekli

### a) Gecikmeli frenleme

Genellikle sistemin yavaş ve kaydırılarak durması gereken yerlerde tercih edilen bağlantı şeklindedir. Vinç yürütme motorlarındaki sarsıntıyı önlemek için gecikmeli bağlantı şekli kullanılır. Frenler fabrika çıkışında gecikmeli bağlantıya uygun ayarlanır.

### b) Ani frenleme

Genellikle sistemin enerjisi kesildiği anda ani olarak durdurulması gereken sistemlerde kullanılan bağlantı şeklindedir. Vinç kaldırma sistemleri, asansör motorlarında kullanılan bağlantı şeklindedir.

## d) Shock voltage supply transformer

Brakes which consist of high power and torques take long time to get in electromagnetic field. Shock voltage supply transformers with time relay are aiming to overcome spring pressure delaying for brakes. Also this transformers provide to open system suddenly by feeding double(48V DC) voltage in a short time and preventing to frictional loses occurring in delayed opening.

## Connection Types

### a) Delayed Braking

Generally this type of connection uses in slow and sliding brake intended systems. Delayed connection type using to prevent shock loadings in crane driving systems. Brakes are setting up to delayed connection if any other types are not specified by customer

### b) Sudden Braking

This type of connections are mostly used in systems when short braking times are needed. The braking torque will be produced as soon as the current fails. These brakes are mostly used in hoisting of lifting units and elevators.

## d) Trafos mit Schock-Spannung

Diese Transformatoren werden bei großen Bremsen mit hohen Momenten verwendet. Da die große Bremsen eine lange Zeit braucht, um die erforderliche magnetische Feld zu erzeugen, wird an der Bremse kurz 48V Gleichstromspannung angelegt, um die Zeit zur Bildung von magnetischem Feld zu kürzen. Dies ermöglicht kürzere Reibungszeiten beim Start.

## Schaltungsarten:

### a) Verspätetes Bremsen

Diese Schaltung wird benutzt, wenn ein langsames und gleitendes Bremsen erforderlich ist. Am meisten wird es bei Fahrtriebmotoren von Aufzügen verwendet. Wenn keine Angabe bei der Bestellung gegeben wird, werden die Bremsen mit verspäteter Schaltung geliefert.

### b) Schnelles Bremsen:

Allgemein verwendet man diese Schaltung bei Bedarf an plötzlichen Bremsen in dem Augenblick, in dem das System keine Energie mehr erhält. Diese Schaltungsart wird meist bei Kränen und Motoren von Aufzüge verwendet.

**Gecikmeli Frenleme / Delayed Running Brake / Verspätete Bremsung**  
( 230 V AC-98V DC)

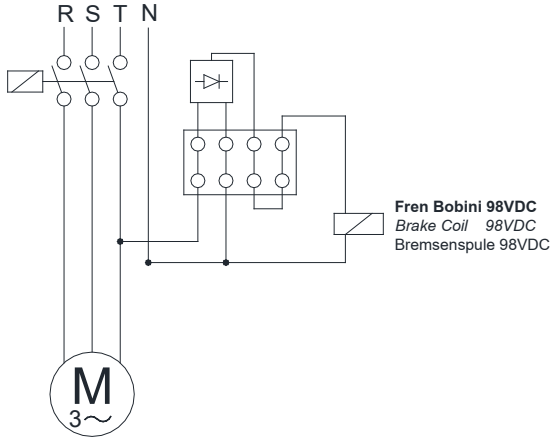

**Ani Frenleme / Sudden Brake / Plötzliche Bremsung**  
( 230 V AC-98V DC)

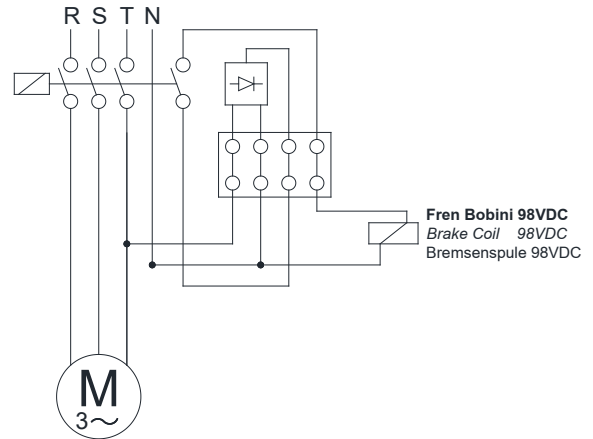

**Gecikmeli Frenleme / Delayed Running Brake / Verspätete Bremsung**  
( 230 V AC-24V DC)

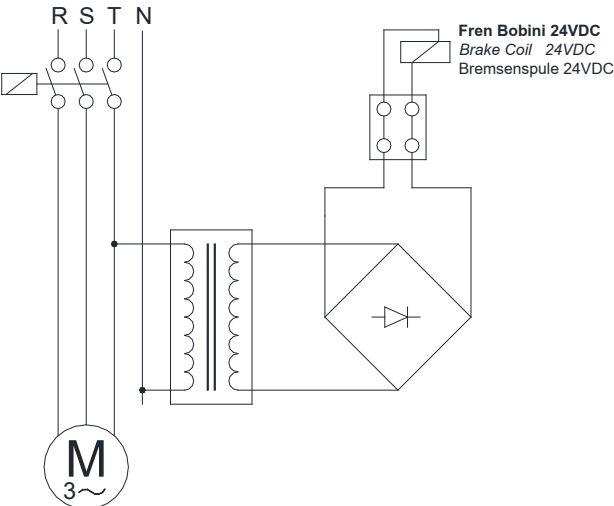

**Ani Frenleme / Sudden Brake / Plötzliche Bremsung**  
( 230 V AC-24V DC)

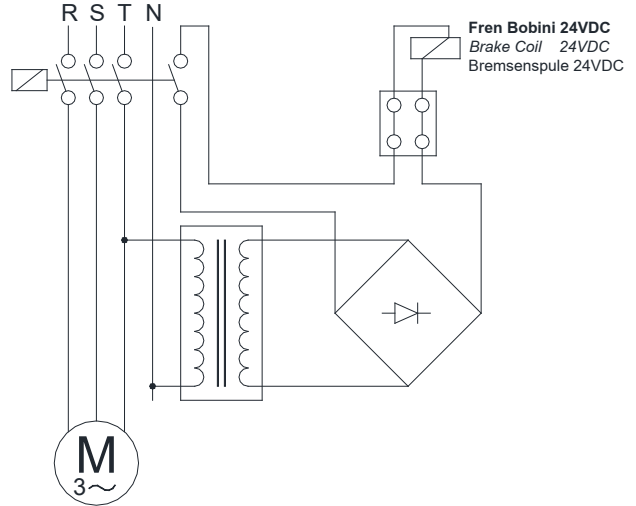

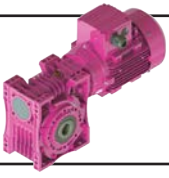

# Genel Bilgiler

## General Information

### Einführung



#### Fren Seçimi:

Doğru bir fren seçimi için aşağıdaki parametreler bilinmelidir.

- $I_{tot}$  [kg.m<sup>2</sup>] : Motor miline indirgenmiş toplam atalet momenti
- $n_0$  [d/dak] : Maksimum motor devir sayısı
- $t_f$  [s] : İstenilen en uzun frenleme zamanı
- $c_t$  : Anahtarın devreye girme zamanı katsayısı (ortalama 0,995).
- $M_L$  [Nm] : Sistemin statik tork ihtiyacı.
- $C_s$  : Emniyet katsayısı ( $C_s \geq 2$  olmalı)

Gerekli fren momenti aşağıdaki şekilde hesaplanır:

a)  $M_L$  Statik yük torku, motor dönüş yönünde (motorun dönüşüne yardımcı olarak, yükün indirilmesi veya hızlandırıcı sabit yük momenti hali):

$$M_{fc} = \frac{(2\pi \times n_0 \div 60) \times I_{tot}}{t_f \times c_t} + M_L$$

b)  $M_L$  Statik yük torku, motor aksi dönüş yönünde (motorun dönüşüne engel olarak, yükün yukarı kaldırılması veya frenleyici sabit yük/direnç momenti hali):

$$M_{fc} = \frac{(2\pi \times n_0 \div 60) \times I_{tot}}{t_f \times c_t} - M_L$$

Yukarıda bulunan sonuç  $C_s$  katsayısı ile çarpılarak ( $C_s \geq 2$ ), fren momenti seçilir;

$$M_f = M_{fc} \times C_s$$

#### Yaklaşım Yolu ile Fren Seçimi:

Eğer yalnızca motorun gücü ve en yüksek devri biliniyor ise :

W [Watt]: Motorun nominal gücü

$$M_f = \frac{W}{\frac{2\pi \times n_0}{60}} \times C_s \quad (C_s \geq 2)$$

#### Brake Selection:

To select a brake correctly the following data are necessary;

- $I_{tot}$  [kg . m<sup>2</sup>] : The total inertia of rotating parts reduced at the motor shaft
- $n_0$  [rpm] : Maximum motor speed.
- $t_f$  [s] : The maximum admitted time of the braking.
- $c_t$  : Coefficient of switch on time (average 0,995).
- $M_L$  [Nm] : Required static torque of system.
- $C_s$  : Safety coefficient ( $C_s \geq 2$ )

The necessary braking torque calculates below;

a) The static load torque  $M_L$ , same direction of motor rotation (Descent of a load or steady resisting torque which favours the rotation of the motor)

$$M_{fc} = \frac{(2\pi \times n_0 \div 60) \times I_{tot}}{t_f \times c_t} + M_L$$

b) The static load torque  $M_L$ , opposes the rotation of the motor (Lifting of a load or steady resisting torque which opposes the rotation of the motor)

$$M_{fc} = \frac{(2\pi \times n_0 \div 60) \times I_{tot}}{t_f \times c_t} - M_L$$

The necessary braking torque will result from the following equation using  $C_s$  ( $C_s \geq 2$ );

$$M_f = M_{fc} \times C_s$$

#### Approximated Brake Selection

Its only the motor power and its maximum speed are known:

W [Watt]: Motor Nominal Power

$$M_f = \frac{W}{\frac{2\pi \times n_0}{60}} \times C_s \quad (C_s \geq 2)$$

#### Bremswahl:

Um die richtige Bremse auszuwählen, braucht man unten aufgelistete Variablen;

- $I_{tot}$  [kg . m<sup>2</sup>] : Die Gesamtträgheit der rotierenden Teile (siehe Anwendungsbeispiele)
- $n_0$  [U/min] : Die höchste Drehzahl des Motors
- $t_f$  [s] : Die längste zulässige Bremszeit
- $c_t$  : Reduktionskoeffizient der Tätigkeitszeit (gemittelt 0,995).
- $M_L$  [Nm] : Vom system benötigtes, statisches Drehmoment.
- $C_s$  : Sicherheitskoeffizient ( $C_s \geq 2$ )

Die benötigte Bremskraft wird wie folgt berechnet:

a) konstantes Belastungsmoment  $M_L$ , das die Motordrehung fördert (konstante Erhöhung der Motorgeschwindigkeit oder Herunterlassen der Last)

$$M_{fc} = \frac{(2\pi \times n_0 \div 60) \times I_{tot}}{t_f \times c_t} + M_L$$

b) konstantes Belastungsmoment  $M_L$ , das sich entgegen der Motordrehung widersetzt (konstante Verminderung der Motorgeschwindigkeit oder Aufheben der Last)

$$M_{fc} = \frac{(2\pi \times n_0 \div 60) \times I_{tot}}{t_f \times c_t} - M_L$$

Wenn die Bremskraft mit dem Sicherheitskoeffizient  $C_s$  ( $C_s \geq 2$ ) multipliziert wird, erhält man die erforderliche Bremskraft;

$$M_f = M_{fc} \times C_s$$

#### Abschätzung zur Bremswahl

Wenn man nur die Motorleistung und die höchste Drehzahl kennt, kann die Bremskraft mit der folgenden Formel annähernd berechnet werden: W [Watt] : Nennleistung des Motors

$$M_f = \frac{W}{\frac{2\pi \times n_0}{60}} \times C_s \quad (C_s \geq 2)$$

#### Standart Frener / Standard Brakes / Standart Bremsen

<b>Fren statik momenti [Nm]</b> Brake Static Torque [Nm] Statische Bremskraft [Nm]	4,5	8	12	16	35	60	80	150	200
<b>Fren Dinamik Momenti [Nm]</b> Brake Dynamic Torque [Nm] Dynamische Bremskraft [Nm]	3,6	6,4	9,6	12,8	28	48	64	120	160
<b>Maksimum Motor Hızı [d/dak]</b> Maximum Motor Speed [rpm] Maximale Motordrehzahl [U/min]	3000	3000	3000	3000	3000	3000	3000	1500	1500
<b>Giriş Gücü [W]</b> Input Power [W] Antriebsleistung [W]	15	20	25	30	45	50	55	60	65

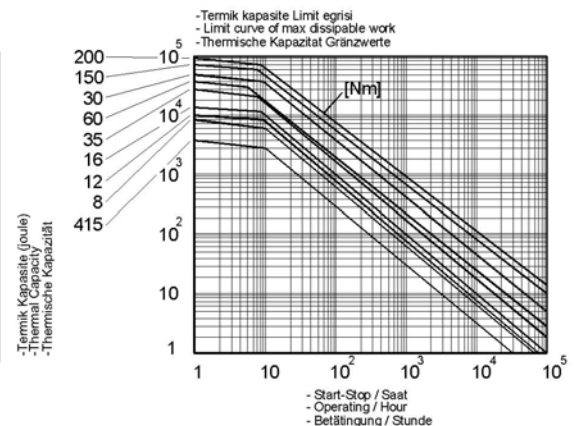

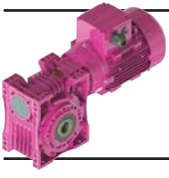

# Genel Bilgiler

## General Information

### Einführung



#### Frenin Termik Kapasitesi

Yukarıdaki seçime ek olarak frenin termik kapasitesinin kontrol edilmesi gerekir. L (joule) olarak gerekli soğutma işi aşağıdaki formüller ile hesaplanır ve "Termik kapasite limit eğrisi" kullanılarak eğrinin altında kalıp kalmadığı kontrol edilir.

a)  $M_L$  Statik yük torku motor dönüş yönünde (motorun dönüşüne yardımcı olarak, yükün indirilmesi hali)

$$L = \frac{I_{tot} \times (2\pi \times n_0 \div 60)^2}{2} \times \left( \frac{M_f}{M_f - M_L} \right)$$

b)  $M_L$  Statik yük torku motor aksi dönüş yönünde (motorun dönüşüne engel olarak, yükün kaldırılması hali):

$$L = \frac{I_{tot} \times (2\pi \times n_0 \div 60)^2}{2} \times \frac{M_f}{M_f + M_L}$$

c)  $M_L$  Statik yük torku sabit, motor yönünde veya aksi yönde (kaldırma ve indirme harici hızlandırıcı veya frenleyici sabit bir yük momenti hali).

$$L = \frac{I_{tot} \times (2\pi \times n_0 \div 60)^2}{2}$$

#### Fren Hava Boşluğunun Ayarı:

Frenin sürekli aynı performansın alınabilmesi için, fren balatasının aşınmasına bağlı olarak, fren hava boşluğu belirli zaman aralıklarında yeniden ayarlanmalıdır. Fren hava boşluğu ayar zaman aralığı ve ayarın yapılması için firmamıza danışınız.

#### Fren Seçim Örneği:

İstenilen en uzun frenleme zamanı: 0,5 sn.  
Motor devri: 1400 d/dak  
Motora indirgenmiş toplam atalet momenti: 0,08 kgm<sup>2</sup>

Gerekli çalışma momenti: 50 Nm

Yük Durumu: Yük motor dönüş yönü ile aynı (Vinçten yük indirmesi: Saatte dur-kalk sayısı:30)

$$M_{fc} = \frac{(2\pi \times 1400 \div 60)}{0,5 \times 0,995} + 50 = 73,6 \text{ Nm}$$

$$M_f = 73,6 \times 2 = 147,2 \text{ Nm}$$

Standart frenler tablosundan 150 Nm lik fren seçilebilir.

Gerekli termik kapasite;

$$L = \frac{0,08 \times (2\pi \times 1400 \div 60)^2}{2} \times \left( \frac{147,2}{147,2 - 50} \right)$$

=1302,0 < 18000 Joule (150 Nm eğrisinden)  
150 Nm lik fren uygun görülüyor.

#### The Thermal Capacity of Brake

The thermal capacity of the brake must also be checked after the above mentioned calculations heat dissipation energy L (joule) can be calculated from the following equation and must be checked if the result is under the limit curve shown on "Limit curve of may dissipated work".

a) The static load torque  $M_L$ , favours the rotation of the motor (Descent of a load which favours the rotation of the motor)

$$L = \frac{I_{tot} \times (2\pi \times n_0 \div 60)^2}{2} \times \left( \frac{M_f}{M_f - M_L} \right)$$

b) The static load torque  $M_L$ , opposes the rotation of the motor (Lifting of a load which opposes the rotation of the motor)

$$L = \frac{I_{tot} \times (2\pi \times n_0 \div 60)^2}{2} \times \frac{M_f}{M_f + M_L}$$

c) The static load torque  $M_L$ , is constant and opposes or favours the rotation of the motor (except lifting of a load)

$$L = \frac{I_{tot} \times (2\pi \times n_0 \div 60)^2}{2}$$

#### Adjustment of the air-gap:

In order to obtain the same performance from the brake during its lifetime, the air-gap of the brake must be re-adjusted after a limited time of operation. For the air-gap and the time interval of the adjustment please contact us.

#### Selection Example:

The maximum admitted time for braking 0,5 s  
Motor speed: 1400 rpm  
Total inertia reduced at motor shaft: 0,08 kgm<sup>2</sup>

Required operating torque: 50 Nm

Nature of load: Load direction is same as motor direction (Unloading process: Start-stop time per hour :30)

$$M_{fc} = \frac{(2\pi \times 1400 \div 60)}{0,5 \times 0,995} + 50 = 73,6 \text{ Nm}$$

$$M_f = 73,6 \times 2 = 147,2 \text{ Nm}$$

From the brake selection table a standard brake of 150 Nm is selected.

Necessary thermal capacity

$$L = \frac{0,08 \times (2\pi \times 1400 \div 60)^2}{2} \times \left( \frac{147,2}{147,2 - 50} \right)$$

=1302,0 < 18000 Joule (from 150 Nm curve)  
The selected brake with 150 Nm is suitable.

#### Thermische Kapazität der Bremsen

Nach den oben genannten Berechnungen muss die thermische Kapazität überprüft werden. Die Wärme, d.h. die gebrauchte Energie L, werden mit den folgenden Formeln berechnet. Die gerechnete Werte von Kapazitäten sollen unter dem Grenzkurve "Thermische Kapazität Grenzwerte" der gewählten Bremse liegen.

a) Konstantes Belastungsmoment  $M_L$ , das die Motordrehung fördert (Herunterlassen der Last)

$$L = \frac{I_{tot} \times (2\pi \times n_0 \div 60)^2}{2} \times \left( \frac{M_f}{M_f - M_L} \right)$$

b) Konstantes Belastungsmoment  $M_L$ , das sich entgegen der Motordrehung widersetzt (Aufheben der Last)

$$L = \frac{I_{tot} \times (2\pi \times n_0 \div 60)^2}{2} \times \frac{M_f}{M_f + M_L}$$

c) Konstantes Belastungsmoment  $M_L$ , das sich gegen der Motorbewegung widersetzt oder die Motorrotation fördert (Konstante Verminderung oder Erhöhung der Motorgeschwindigkeit, kein Herunterlassen oder Aufheben der Last)

$$L = \frac{I_{tot} \times (2\pi \times n_0 \div 60)^2}{2}$$

#### Einstellung des Luftspaltes:

Um eine immer konstant bleibende Bremsfähigkeit zu erhalten, muss das Luftspalt nach einer bestimmten Arbeitszeit neu eingestellt werden. Für die Bestimmung des Luftspaltes und die Einstellzeiten bitten wir Sie um Rückfrage.

#### Beispiel für eine Auswahl:

Die höchste zulässige Bremszeit: 0,5 s  
Motordrehzahl: 1400 U/min  
Gesamtträgheit der rotierenden Teile: 0,08 kgm<sup>2</sup>

Das auf das System wirkende Drehmoment: 50 Nm

Belastungsart: Drehmoment, das die Motorrotation fördert (Herunterlassen der Last)  
Betätigungen pro Stunde:30

$$M_{fc} = \frac{(2\pi \times 1400 \div 60)}{0,5 \times 0,995} + 50 = 73,6 \text{ Nm}$$

$$M_f = 73,6 \times 2 = 147,2 \text{ Nm}$$

Eine Bremse von 150 Nm kann man auswählen.

Die thermische Kapazität;

$$L = \frac{0,08 \times (2\pi \times 1400 \div 60)^2}{2} \times \left( \frac{147,2}{147,2 - 50} \right)$$

=1302,0 < 18000 Joule (von 150 Nm Kurve) Die ausgewählte 150 Nm Bremse ist ausreichend.

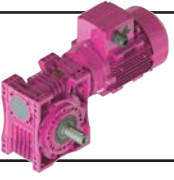

# Güç ve Devir Tabloları

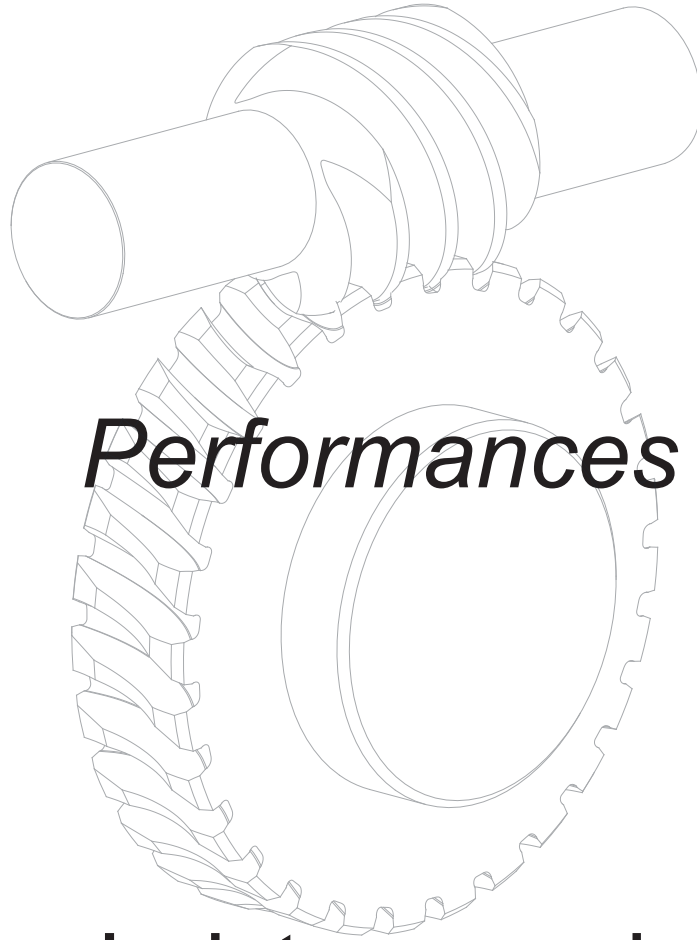

## Leistung und Drehzahlübersicht

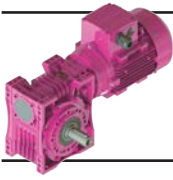

# E Serisi Motorlu Güç Devir Sayfaları

## E Series Geared Motors Performance Tables

### E Serien Getriebemotoren Leistung und Drehzahlübersicht

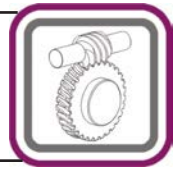

Güç	Çıkış Devri	Çıkış Momenti	Çıkış Gücü	Çevrim Oranı	Güv. Rad. Yük Çıkış	Servis Faktörü	Tipi	Anma Akımı	Ağırlık	Ölçü Sayfası	Motor Verim Snf.
Power	Output Speeds	Output Torque	Output Power	Ratio	Per.O. Loads (Output)	Service Factors	Type	Rated Current	Weight	Dim. Page	Motor Eff. Class
Leistung P <sub>g</sub> [KW] P <sub>g</sub> [HP]	Abtriebswelle Drehzahlen n <sub>2</sub> [r.p.m]	Abtriebswelle Drehmomente M <sub>2</sub> [Nm]	Abtriebswelle Leistung P2 [kW]	Übersetzung i	Zul.Querkräfte (Abtrieb) F <sub>qam</sub> [N]	Betriebsfaktor f <sub>s</sub>	Typ	Nennstrom [A]	Gewicht ~ [kg]	Maß Seite	Motor Effizienz-klasse
0,06 0,08	0,28	199	0,01	4920	6200	0,5	EV063-E030-G56/4a	0,25	10,3	102	IE1
	0,37	152	0,01	3660	6200	0,7					
	0,45	187	0,01	3060	6200	0,7					
	0,59	149	0,01	2340	6200	0,8					
	0,79	110	0,01	1740	6200	0,9					
	0,94	100	0,01	1450	6200	1,0					
	1,1	124	0,01	1218	6200	1,1					
	1,4	105	0,02	986	6200	1,3					
	1,6	97	0,02	841	6200	1,4					
	1,9	87	0,02	725	6200	1,5					
	2,2	78	0,02	609	6200	1,7					
	2,8	66	0,02	493	6200	1,9					
	3,3	60	0,02	420,5	6200	2,1					
	4,5	46	0,02	304,5	6200	2,7					
0,28	0,28	214	0,01	4980	4800	0,3	EV050-E030-G56/4a	0,25	8	101	IE1
	0,37	152	0,01	3720	4800	0,3					
	0,46	162	0,01	3000	4800	0,3					
	0,60	139	0,01	2280	4800	0,5					
	0,79	111	0,01	1740	4800	0,5					
	0,94	100	0,01	1450	4800	0,5					
	1,1	88	0,01	1218	4800	0,6					
	1,4	105	0,02	986	4800	0,7					
	1,6	85	0,01	870	4800	0,9					
	1,9	77	0,02	725	4800	1,0					
	2,2	67	0,02	609	4800	1,1					
	2,8	72	0,02	493	4800	1,3					
	3,3	67	0,02	420,5	4800	1,4					
	3,8	60	0,02	362,5	4800	1,6					
	4,5	54	0,03	304,5	4800	1,7					
	5,5	46	0,03	246,5	4800	2,0					
	6,5	41	0,03	210,25	4800	2,2					
7,9	37	0,03	174	4800	2,5						
10	32	0,03	137,75	4800	2,8						
0,37	0,37	141	0,01	3720	3400	0,2	EV040-E030-G56/4a	0,25	6,2	100	IE1
	0,46	154	0,01	3000	3400	0,2					
	0,54	153	0,01	2520	3400	0,2					
	0,71	149	0,01	1920	3400	0,2					
	0,86	134	0,01	1600	3400	0,2					
	1,0	118	0,01	1344	3400	0,3					
	1,3	99	0,01	1088	3400	0,3					
	1,4	106	0,02	960	3400	0,5					
	1,7	96	0,02	800	3400	0,5					
	2,0	84	0,02	672	3400	0,6					
	2,5	71	0,02	544	3400	0,7					
	2,9	65	0,02	480	3400	1,0					
	3,4	58	0,02	400	3400	1,1					
	4,1	51	0,02	336	3400	1,2					
	5,0	43	0,02	272	3400	1,4					
	5,9	40	0,02	232	3400	1,5					
	6,9	42	0,03	200	3400	1,7					
8,2	37	0,03	168	3400	1,8						
10	32	0,03	136	3400	2,1						
12	29	0,04	116	3400	2,3						
16	22	0,04	84	3400	2,8						



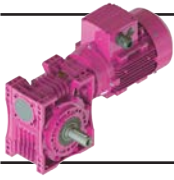

# E Serisi Motorlu Güç Devir Sayfaları

## E Series Geared Motors Performance Tables

### E Serien Getriebemotoren Leistung und Drehzahlübersicht

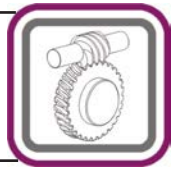

Güç	Çıkış Devri	Çıkış Momenti	Çıkış Gücü	Çevrim Oranı	Güv. Rad. Yük Çıkış	Servis Faktörü	Tipi	Anma Akımı	Ağırlık	Ölçü Sayfası	Motor Verim Snf.
Power	Output Speeds	Output Torque	Output Power	Ratio	Per.O. Loads (Output)	Service Factors	Type	Rated Current	Weight	Dim. Page	Motor Eff. Class
Leistung	Abtriebswelle Drehzahlen	Abtriebswelle Drehmomente	Abtriebswelle Leistung	Übersetzung	Zul.Querkräfte (Abtrieb)	Betriebsfaktor	Typ	Nennstrom	Gewicht ~	Maß Seite	Motor Effizienz-klasse
$P_g$ [kW] $P_g$ [HP]	$n_2$ [r.p.m]	$M_2$ [Nm]	$P2$ [kW]	$i$	$F_{qam}$ [N]	$f_s$		[A]	[kg]		
<b>0,06</b> 0,08	17	8	0,01	<b>80</b>	1830	0,6	<b>EV030-G56/4a</b>	0,25	3,9	68	IE1
	23	12	0,03	<b>60</b>	1830	0,8					
	27	11	0,03	<b>50</b>	1830	1,3					
	33	10	0,03	<b>42</b>	1830	1,6					
	40	8	0,03	<b>34</b>	1830	2,1					
	47	8	0,04	<b>29</b>	1830	2,3					
	55	7	0,04	<b>25</b>	1830	2,6					
	65	6	0,04	<b>21</b>	1743	2,8					
	81	5	0,04	<b>17</b>	1631	3,5					
	94	5	0,05	<b>14,5</b>	1551	3,9					
	130	4	0,05	<b>10,5</b>	1396	4,7					
	189	3	0,05	<b>7,25</b>	1241	6,5					
	261	2	0,05	<b>5,25</b>	1115	9,6					
<b>0,09</b> 0,12	1,1	185	0,02	<b>1218</b>	6200	0,7	<b>EV063-E030-G56/4b</b>	0,63	10,4	102	IE1
	1,4	156	0,02	<b>986</b>	6200	0,9					
	1,6	145	0,02	<b>841</b>	6200	0,9					
	1,9	130	0,03	<b>725</b>	6200	1,0					
	2,3	117	0,03	<b>609</b>	6200	1,1					
	2,8	99	0,03	<b>493</b>	6200	1,3					
	3,3	89	0,03	<b>420,5</b>	6200	1,4					
	4,5	68	0,03	<b>304,5</b>	6200	1,8					
	6,5	60	0,04	<b>210,25</b>	6200	2,4					
	2,3	100	0,02	<b>609</b>	4800	0,8					
	2,8	108	0,03	<b>493</b>	4800	0,9					
	3,3	101	0,03	<b>420,5</b>	4800	0,9					
	3,8	90	0,04	<b>362,5</b>	4800	1,0					
	4,5	81	0,04	<b>304,5</b>	4800	1,1					
	5,6	69	0,04	<b>246,5</b>	4800	1,3					
	6,5	62	0,04	<b>210,25</b>	4800	1,4					
	7,9	55	0,05	<b>174</b>	4800	1,7					
	10	48	0,05	<b>137,75</b>	4800	1,9					
	4,1	76	0,03	<b>336</b>	3400	0,8	<b>EV040-E030-G56/4b</b>	0,63	6,3	100	IE1
	5,1	64	0,03	<b>272</b>	3400	1,0					
	5,9	60	0,04	<b>232</b>	3400	1,0					
	6,9	62	0,04	<b>200</b>	3400	1,1					
	8,2	56	0,05	<b>168</b>	3400	1,2					
	10	48	0,05	<b>136</b>	3400	1,4					
	12	43	0,05	<b>116</b>	3400	1,5					
	16	33	0,06	<b>84</b>	3400	1,9					
	23	18	0,04	<b>60</b>	1830	0,5	<b>EV030-G56/4b</b>	0,63	4	68	IE1
28	16	0,05	<b>50</b>	1830	0,9						
33	14	0,05	<b>42</b>	1830	1,1						
40	12	0,05	<b>34</b>	1830	1,4						
47	11	0,06	<b>29</b>	1830	1,5						
55	10	0,06	<b>25</b>	1784	1,7						
65	9	0,06	<b>21</b>	1686	1,9						
81	8	0,07	<b>17</b>	1580	2,3						
95	7	0,07	<b>14,5</b>	1504	2,6						
131	5	0,07	<b>10,5</b>	1356	3,2						
190	4	0,08	<b>7,25</b>	1209	4,3						
262	3	0,08	<b>5,25</b>	1087	6,4						

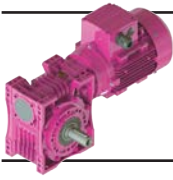

# E Serisi Motorlu Güç Devir Sayfaları

## E Series Geared Motors Performance Tables

### E Serien Getriebemotoren Leistung und Drehzahlübersicht

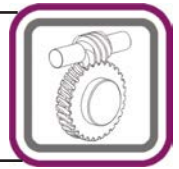

Güç Power	Çıkış Devri Output Speeds	Çıkış Momenti Output Torque	Çıkış Gücü Output Power	Çevrim Oranı Ratio	Güv. Rad. Yük Çıkış Per.O. Loads (Output)	Servis Faktörü Service Factors	Tipi Type	Anma Akımı Rated Current	Ağırlık Weight	Ölçü Sayfası Dim. Page	Motor Verim Snf. Motor Eff. Class
Leistung P <sub>g</sub> [kW] P <sub>g</sub> [HP]	Abtriebswelle Drehzahlen n <sub>2</sub> [r.p.m]	Abtriebswelle Drehmomente M <sub>2</sub> [Nm]	Abtriebswelle Leistung P2 [kW]	Übersetzung i	Zul.Querkräfte (Abtrieb) F <sub>qam</sub> [N]	Betriebsfaktor f <sub>s</sub>	Typ	Nennstrom [A]	Gewicht ~ [kg]	Maß Seite	Motor Effizienz-klasse
0,12 0,16	0,73	265	0,02	1860	7400	0,8	EV080-E040-G63/4a	0,41	16,6	104	IE1
	0,91	346	0,03	1500	7400	0,8					
	1,1	315	0,04	1260	7400	0,9					
	1,5	141	0,02	930	7400	2,1					
	1,8	235	0,04	750	7400	1,6					
	2,2	214	0,05	630	7400	1,7					
	2,8	180	0,05	480	7400	2,0					
	3,6	147	0,06	375	7400	2,4					
1,1 1,5 1,8 2,2 2,8 3,6 4,3 5,7 7,6	1,1	349	0,04	1260	7000	0,6	EV075-E040-G63/4a	0,41	15	103	IE1
	1,5	154	0,02	930	7000	1,5					
	1,8	203	0,04	750	7000	1,1					
	2,2	228	0,05	630	7000	1,3					
	2,8	192	0,06	480	7000	1,5					
	3,6	157	0,06	375	7000	1,8					
	4,3	135	0,06	315	7000	2,0					
	5,7	107	0,06	240	7000	2,5					
7,6	83	0,07	180	7000	3,1						
1,9 2,2 2,8 3,2 4,5 6,5	1,9	175	0,03	725	6200	0,8	EV063-E030-G63/4a	0,41	10,8	102	IE1
	2,2	157	0,04	609	6200	0,8					
	2,8	133	0,04	493	6200	1,0					
	3,2	120	0,04	420,5	6200	1,1					
	4,5	92	0,04	304,5	6200	1,4					
	6,5	81	0,05	210,25	6200	1,8					
3,7 4,5 5,8 7,8 8,9 12	3,7	122	0,05	366	6200	0,8	EV063-NR01-G63/4a	0,41	15,6	108	IE1
	4,5	131	0,06	306	6200	0,9					
	5,8	103	0,06	234	6200	1,2					
	7,8	77	0,06	174	6200	1,9					
	8,9	85	0,08	153	6200	1,6					
	12	67	0,08	117	6200	2,2					
2,8 3,2 3,8 4,5 5,5 6,5 7,8 10	2,8	145	0,04	493	4800	0,7	EV050-E030-G63/4a	0,41	8,5	101	IE1
	3,2	135	0,05	420,5	4800	0,7					
	3,8	121	0,05	362,5	4800	0,8					
	4,5	109	0,05	304,5	4800	0,9					
	5,5	93	0,05	246,5	4800	1,0					
	6,5	83	0,06	210,25	4800	1,1					
	7,8	74	0,06	174	4800	1,2					
	10	65	0,07	137,75	4800	1,4					
7,8 9,1 12 16	7,8	77	0,06	174	4800	1,0	EV050-NR01-G63/4a	0,41	13,3	107	IE1
	9,1	80	0,08	150	4800	1,0					
	12	64	0,08	114	4800	1,3					
	16	50	0,08	87	4800	1,8					
5,0 5,9 6,8 8,1 10 12 16	5,0	87	0,05	272	3400	0,7	EV040-E030-G63/4a	0,41	6,7	100	IE1
	5,9	80	0,05	232	3400	0,8					
	6,8	84	0,06	200	3400	0,8					
	8,1	75	0,06	168	3400	0,9					
	10	64	0,07	136	3400	1,0					
	12	57	0,07	116	3400	1,1					
	16	44	0,07	84	3400	1,4					

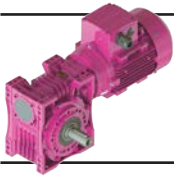

# E Serisi Motorlu Güç Devir Sayfaları

## E Series Geared Motors Performance Tables

### E Serien Getriebemotoren Leistung und Drehzahlübersicht

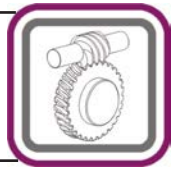

Güç	Çıkış Devri	Çıkış Momenti	Çıkış Gücü	Çevrim Oranı	Güv. Rad. Yük Çıkış	Servis Faktörü	Tipi	Anma Akımı	Ağırlık	Ölçü Sayfası	Motor Verim Snf.						
Power	Output Speeds	Output Torque	Output Power	Ratio	Per.O. Loads (Output)	Service Factors	Type	Rated Current	Weight	Dim. Page	Motor Eff. Class						
Leistung P <sub>g</sub> [kW] P <sub>g</sub> [HP]	Abtriebswelle Drehzahlen n <sub>2</sub> [r.p.m]	Abtriebswelle Drehmomente M <sub>2</sub> [Nm]	Abtriebswelle Leistung P2 [kW]	Übersetzung i	Zul. Querkräfte (Abtrieb) F <sub>qam</sub> [N]	Betriebsfaktor f <sub>s</sub>	Typ	Nennstrom [A]	Gewicht ~ [kg]	Maß Seite	Motor Effizienz-klasse						
<b>0,12</b> 0,16	14	14	0,02	<b>100</b>	3400	0,7	<b>EV040-G63/4a</b>	0,41	5,6	72	IE1						
	17	17	0,03	<b>80</b>	3340	0,9											
	22	19	0,04	<b>62</b>	3026	1,4											
	27	25	0,07	<b>50</b>	2734	1,5											
	33	23	0,08	<b>42</b>	2586	1,7											
	43	19	0,09	<b>32</b>	2375	2,0											
	55	16	0,09	<b>25</b>	2198	2,6											
	65	13	0,09	<b>21</b>	2084	3,0											
	85	11	0,10	<b>16</b>	1914	3,8											
	114	8	0,10	<b>12</b>	1746	5,4											
	130	7	0,10	<b>10,5</b>	1673	5,5											
	171	6	0,10	<b>8,0</b>	1531	7,2											
		27	22	0,06	<b>50</b>	1830						0,6	<b>EV030-G63/4a</b>	0,41	4,4	64	IE1
		33	19	0,07	<b>42</b>	1830						0,8					
		40	16	0,07	<b>34</b>	1830						1,0					
		47	15	0,07	<b>29</b>	1830						1,1					
		55	14	0,08	<b>25</b>	1787						1,3					
65		12	0,08	<b>21</b>	1689	1,4											
80		10	0,09	<b>17</b>	1583	1,7											
94		9	0,09	<b>14,5</b>	1507	1,9											
130		7	0,10	<b>10,5</b>	1359	2,4											
188		5	0,10	<b>7,25</b>	1212	3,2											
260		4	0,11	<b>5,25</b>	1089	4,8											
<b>0,18</b> 0,25		1,5	318	0,05	<b>930</b>	7400	0,9	<b>EV080-E040-G63/4b</b>	0,6	17,1	104	IE1					
		1,8	240	0,07	<b>750</b>	7400	1,0										
	2,1	215	0,07	<b>630</b>	7400	1,1											
	2,8	183	0,08	<b>480</b>	7400	1,3											
	3,6	150	0,08	<b>375</b>	7400	1,6											
	4,3	129	0,09	<b>315</b>	7400	1,8											
	5,6	103	0,09	<b>240</b>	7400	2,2											
	7,4	80	0,09	<b>180</b>	7400	2,7											
		1,4	154	0,03	<b>930</b>	7000	1,0						<b>EV075-E040-G63/4b</b>	0,6	15	103	IE1
		1,8	207	0,06	<b>750</b>	7000	0,8										
		2,1	229	0,08	<b>630</b>	7000	0,8										
		2,8	195	0,09	<b>480</b>	7000	1,0										
		3,6	160	0,09	<b>375</b>	7000	1,2										
		4,3	138	0,09	<b>315</b>	7000	1,3										
5,6		109	0,10	<b>240</b>	7000	1,6											
7,4		85	0,10	<b>180</b>	7000	2,0											
		3,6	158	0,09	<b>372,5</b>	7000	0,8	<b>EV075-NR11-G63/4b</b>	0,6	16	109	IE1					
		4,5	138	0,10	<b>298</b>	7000	1,0										
	6,0	111	0,10	<b>223,5</b>	7000	1,4											
	7,2	103	0,12	<b>186,25</b>	7000	1,6											
	9,0	87	0,12	<b>149</b>	7000	1,9											
	12	69	0,13	<b>111,75</b>	7000	2,6											
		4,4	93	0,06	<b>304,5</b>	6200	0,9						<b>EV063-E030-G63/4b</b>	0,6	11,3	102	IE1
6,4		82	0,08	<b>210,25</b>	6200	1,2											
	5,7	105	0,09	<b>234</b>	6200	0,8	<b>EV063-NR01-G63/4b</b>	0,6	16,1	108	IE1						

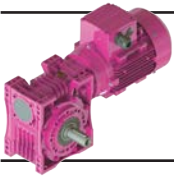

# E Serisi Motorlu Güç Devir Sayfaları

## E Series Geared Motors Performance Tables

### E Serien Getriebemotoren Leistung und Drehzahlübersicht

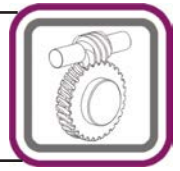

Güç Power Leistung P <sub>g</sub> [kW] P <sub>g</sub> [HP]	IE3	IE3	IE3	Çevrim Oranı Übersetzung i	IE3	IE3	Tipi Type Typ	Anma Akımı Rated Current Nennstrom [A]	Ağırlık Weight Gewicht ~ [kg]	Ölçü Sayfası Dim. Page Maß Seite	Motor Verim Snf. * Motor Eff. Class Motor Effizienz- klasse
	Çıkış Devri Output Speeds Abtriebswelle Drehzahlen n <sub>2</sub> [r.p.m]	Çıkış Momenti Output Torque Abtriebswelle Drehmomente M <sub>2</sub> [Nm]	Çıkış Gücü Output Power Abtriebswelle Leistung P <sub>2</sub> [kW]		Güv. Rad. Yük Çıkış Per.O. Loads (Output) Zul.Querkräfte (Abtrieb) F <sub>qam</sub> [N]	Servis Faktörü Service Factors Betriebsfaktor f <sub>s</sub>					Motor Verim Snf. *
0,18 0,25	7,7	78	0,09	174	6200	1,2	EV063-NR01-G63/4b	0,6	16,1	108	IE1
	8,8	86	0,12	153	6200	1,0					
	11	68	0,12	117	6200	1,4					
	9,3	52	0,08	100	6200	1,0	E063-3E71M/6C	0,55	13,5	80	IE3
	11	50	0,09	82	6200	1,4	E063-2E71M/6B	0,60	12,7		IE2
	15	40	0,10	61	6200	2,1					
	18	39	0,11	51	6200	2,1					
	24	31	0,11	39	5936	3,0					
7,7 9,7	75	0,09	174	4800	0,8	EV050-E030-G63/4b	0,6	10,7	101	IE1	
	66	0,10	137,75	4800	0,9						
12 15	65	0,12	114	4800	0,8	EV050-NR01-G63/4b	0,6	13,8	107	IE1	
	51	0,12	87	4800	1,2						
11 15 19 24 32 37 49	52	0,09	83	4800	0,7	EV050-3E71M/6C	0,55	11,2	76	IE3	
	39	0,09	62	4778	1,1						EV050-2E71M/6B
	36	0,10	50	4467	1,3						
	29	0,11	38	4092	1,7						
	23	0,12	29	3755	2,3						
	22	0,13	25	3591	2,4						
	18	0,14	19	3290	2,9						
13 16 22 27 35 46 54	35	0,07	100	4800	0,7	EV050-G63/4b	0,6	7,8	76	IE1	
	38	0,10	83	4723	0,9						
	30	0,10	62	4297	1,3						
	26	0,11	50	4028	1,6						
	21	0,12	38	3685	2,1						
	17	0,13	29	3376	2,8						
	16	0,14	25	3236	2,9						
12 16	58	0,11	116	3400	0,7	EV040-E030-G63/4b	0,6	7,2	100	IE1	
	45	0,11	84	3400	0,9						
19 22 29 37 44 58 78 89	34	0,10	50	2856	0,8	EV040-3E71M/6C	0,55	9,4	72	IE3	
	32	0,11	42	2703	0,9						EV040-2E71M/6B
	27	0,12	32	2491	1,1						
	22	0,13	25	2315	1,4						
	19	0,13	21	2203	1,6						
	16	0,14	16	2030	2,1						
	12	0,14	12	1863	2,9						
	11	0,15	10,5	1786	3,0						
	17 22 27 32 42 54	18	0,05	80	3270	0,6	EV040-G63/4b	0,6	6,5	72	IE1
19		0,06	62	2945	0,9						
25		0,11	50	2610	1,0						
23		0,11	42	2477	1,1						
19		0,13	32	2278	1,3						
16		0,13	25	2114	1,7						

\*: IE2 ve IE3 motorlu redüktör fiyatları farklıdır. / Geared motor prices are different for IE2 and IE3 motors. / Preise von Getrieben mit IE2 und IE3 Motoren sind unterschiedlich.

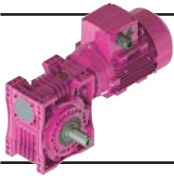

# E Serisi Motorlu Güç Devir Sayfaları

## E Series Geared Motors Performance Tables

### E Serien Getriebemotoren Leistung und Drehzahlübersicht

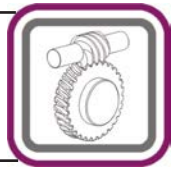

Güç	IE3 Çıkış Devri	IE3 Çıkış Momenti	IE3 Çıkış Gücü	Çevrim Oranı	IE3 Güv. Rad. Yük Çıkış	IE3 Servis Faktörü	Tipi	Anma Akımı	Ağırlık	Ölçü Sayfası	Motor Verim Snf.*	
Power	Output Speeds	Output Torque	Output Power	Ratio	Per.O. Loads (Output)	Service Factors	Type	Rated Current	Weight	Dim. Page	Motor Eff. Class	
Leistung	Abtriebswelle Drehzahlen	Abtriebswelle Drehmomente	Abtriebswelle Leistung	Übersetzung	Zul.Querkräfte (Abtrieb)	Betriebsfaktor	Typ	Nennstrom	Gewicht	Maß Seite	Motor Effizienz-klasse	
P <sub>g</sub> [kW] P <sub>g</sub> [HP]	n <sub>2</sub> [r.p.m]	M <sub>2</sub> [Nm]	P2 [kW]	i	F <sub>qam</sub> [N]	f <sub>s</sub>		[A]	[kg]			
0,18 0,25	64	14	0,14	21	2010	2,0	EV040-G63/4b	0,6	6,5	72	IE1	
	84	11	0,14	16	1853	2,5						
	112	8	0,15	12	1694	3,6						
	128	8	0,15	10,5	1625	3,6						
	168	6	0,16	8,0	1488	4,8						
		39	17	0,10	34	1762	0,7	EV030-G63/4b	0,6	4	64	IE1
		46	15	0,11	29	1688	0,8					
		54	14	0,12	25	1610	0,9					
		64	12	0,12	21	1525	0,9					
		79	11	0,13	17	1440	1,1					
92		9	0,14	14,5	1378	1,3						
128		7	0,15	10,5	1249	1,5						
185		5	0,15	7,25	1125	2,1						
255		4	0,16	5,25	1013	3,1						
0,25 0,34		1,0	742	0,07	1640	13000	1,1					
	1,2	682	0,09	1189	13000	1,7	EV125-E063-2E71M/4B	0,71	74,5		IE2	
	1,6	553	0,09	884,5	13000	2,1						
	1,9	513	0,10	739,5	13000	2,2						
	2,5	410	0,11	565,5	13000	2,8						
		1,2	590	0,07	1240	8200	0,7	EV100-E050-3E71M/4C	0,67	42,6	105	IE3
		1,5	562	0,09	930	8200	1,1	EV100-E050-2E71M/4B	0,71	41,7		IE2
		1,9	489	0,10	750	8200	1,3					
		2,5	400	0,11	570	8200	1,6					
		3,3	324	0,11	435	8200	1,9					
3,8		299	0,12	375	8200	2,0						
5,0		239	0,13	285	8200	2,5						
		3,1	322	0,10	469,35	8200	1,0	EV100-NR11-3E71M/4C	0,67	48,5	111	IE3
		3,7	335	0,13	387,4	8200	1,2	EV100-NR11-2E71M/4B	0,71	47,6		IE2
		4,8	267	0,13	298	8200	1,7					
	6,4	220	0,15	223,5	8200	2,5						
	7,4	219	0,17	193,7	8200	2,2						
	9,6	172	0,17	149	8200	3,1						
	1,9	474	0,09	750	7400	0,8	EV080-E040-3E71M/4C	0,67	20,2	104	IE3	
	2,3	425	0,10	630	7400	0,9	EV080-E040-2E71M/4B	0,71	19,3		IE2	
	3,0	361	0,11	480	7400	1,0						
	3,8	294	0,12	375	7400	1,2						
	4,6	251	0,12	315	7400	1,4						
	6,0	201	0,13	240	7400	1,7						
	8,0	176	0,15	180	7400	2,1						
		4,8	261	0,13	298	7400	1,0	EV080-NR11-3E71M/4C	0,67	23,8	110	IE3
		6,4	202	0,14	223,5	7400	1,5	EV080-NR11-2E71M/4B	0,71	22,9		IE2
		7,3	220	0,17	197,43	7400	1,3					
9,6		167	0,17	149	7400	1,9						
13		129	0,17	111,75	7400	2,7						

\*: IE2 ve IE3 motorlu redüktör fiyatları farklıdır. / Geared motor prices are different for IE2 and IE3 motors. / Preise von Getrieben mit IE2 und IE3 Motoren sind unterschiedlich.

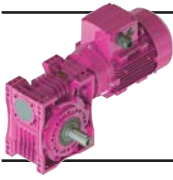

# E Serisi Motorlu Güç Devir Sayfaları

## E Series Geared Motors Performance Tables

### E Serien Getriebemotoren Leistung und Drehzahlübersicht

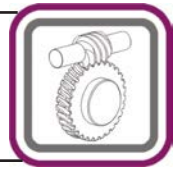

Güç  Power  Leistung P <sub>g</sub> [kW] P <sub>g</sub> [HP]	IE3	IE3	IE3	Çevrim Oranı  Ratio  Übersetzung  i	IE3	IE3	Tipi  Type  Typ	Anma Akımı  Rated Current  Nennstrom  [A]	Ağırlık  Weight  Gewicht  ~ [kg]	Ölçü Sayfası  Dim. Page  Maß Seite	Motor*
	Çıkış Devri	Çıkış Momenti	Çıkış Gücü		Güv. Rad. Yük Çıkış	Servis Faktörü					Motor Verim Snf.
	Output Speeds	Output Torque	Output Power		Per.O. Loads (Output)	Service Factors					Motor Eff. Class
	Abtriebswelle Drehzahlen	Abtriebswelle Drehmomente	Abtriebswelle Leistung		Zul.Querkräfte (Abtrieb)	Betriebsfaktor					Motor Effizienzklasse
n <sub>2</sub> [r.p.m]	M <sub>2</sub> [Nm]	P2 [kW]	F <sub>qam</sub> [N]	f <sub>s</sub>							
0,25 0,34	3	384	0,12	480	7000	0,7	EV075-040-3E71M/4C	0,67	19,9	103	IE3
	4	313	0,13	375	7000	0,9	EV075-040-2E71M/4B	0,71	19,0		IE2
	5	268	0,13	315	7000	1,0					
	6	214	0,13	240	7000	1,2					
	8	166	0,14	180	7000	1,5					
	9	149	0,14	158	7000	1,7					
	12	130	0,16	120	7000	2,1					
	18	93	0,18	80	7000	2,9					
	5	267	0,13	298	7000	0,8	EV075-NR11-3E71M/4C	0,67	20,9	109	IE3
	6	217	0,15	223,5	7000	1,1	EV075-NR11-2E71M/4B	0,71	20,0		IE2
	8	201	0,16	186,25	7000	1,2					
	10	170	0,17	149	7000	1,5					
	13	135	0,18	111,75	7000	2,0					
8,2 9,4 12	152	0,13	174	6200	0,9	EV063-NR01-3E71M/4C	0,67	19,2	108	IE3	
	168	0,17	153	6200	0,8	EV063-NR01-2E71M/4B	0,71	18,3		IE2	
	133	0,17	117	6200	1,1						
9,3 11 15 18 24 32 36	109	0,11	100	6200	0,7	EV063-3E71M/6D	0,77	14,5	80	IE3	
	104	0,12	82	6200	1,0	EV063-2E71M/6C	0,78	13,6		IE2	
	84	0,13	61	6200	1,5						
	80	0,15	51	6200	1,5						
	64	0,16	39	5779	2,1						
	51	0,17	29	5249	3,1						
	49	0,19	25,5	5055	2,7						
14 18 24 28 37	80	0,12	100	6200	1,0	EV063-3E71M/4C	0,67	13,2	80	IE3	
	75	0,14	82	6200	1,4	EV063-2E71M/4B	0,71	12,3		IE2	
	61	0,15	61	5862	2,0						
	56	0,17	51	5544	2,0						
	45	0,17	39	5092	2,8						
15 19 24 32 37 49 64	82	0,13	62	4569	0,8	EV050-3E71M/6D	0,77	9,8	76	IE3	
	74	0,14	50	4279	0,9	EV050-2E71M/6C	0,78	8,9		IE2	
	60	0,15	38	3927	1,2						
	49	0,16	29	3610	1,7						
	47	0,18	25	3460	1,7						
	37	0,19	19	3175	2,1						
	29	0,20	14,5	2923	2,9						
23 29 38 49 57 76	59	0,14	62	4058	1,0	EV050-3E71M/4C	0,67	9,9	76	IE3	
	52	0,16	50	3817	1,2	EV050-2E71M/4B	0,71	9,0		IE2	
	42	0,17	38	3495	1,6						
	34	0,18	29	3206	2,1						
	32	0,19	25	3083	2,2						
	25	0,20	19	2824	2,7						
22 29 37 44	66	0,15	42	2502	0,7	EV040-3E71M/6D	0,77	10,5	72	IE3	
	56	0,17	32	2316	0,8	EV040-2E71M/6C	0,78	9,6		IE2	
	46	0,18	25	2162	1,0						
	40	0,19	21	2065	1,2						

\*: IE2 ve IE3 motorlu redüktör fiyatları farklıdır. / Geared motor prices are different for IE2 and IE3 motors. / Preise von Getrieben mit IE2 und IE3 Motoren sind unterschiedlich.

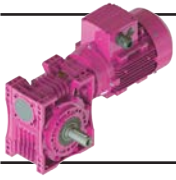

# E Serisi Motorlu Güç Devir Sayfaları

## E Series Geared Motors Performance Tables

### E Serien Getriebemotoren Leistung und Drehzahlübersicht



Güç	IE3 Çıkış Devri	IE3 Çıkış Momenti	IE3 Çıkış Gücü	Çevrim Oranı	IE3 Güv. Rad. Yük Çıkış	IE3 Servis Faktörü	Tipi	Anma Akımı	Ağırlık	Ölçü Sayfası	Motor Verim Snf.*
Power	Output Speeds	Output Torque	Output Power	Ratio	Per.O. Loads (Output)	Service Factors	Type	Rated Current	Weight	Dim. Page	Motor Eff. Class
Leistung	Abtriebswelle Drehzahlen	Abtriebswelle Drehmomente	Abtriebswelle Leistung	Übersetzung	Zul.Querkräfte (Abtrieb)	Betriebsfaktor	Typ	Nennstrom	Gewicht	Maß Seite	Motor Effizienzklasse
P <sub>g</sub> [kW] P <sub>g</sub> [HP]	n <sub>2</sub> [r.p.m]	M <sub>2</sub> [Nm]	P2 [kW]	i	F <sub>qam</sub> [N]	f <sub>s</sub>		[A]	[kg]		
0,25 0,34	58	32	0,20	16	1912	1,5	EV040-3E71M/6D	0,77	10,5	72	IE3
	78	25	0,20	12	1763	2,1	EV040-2E71M/6C	0,78	9,6		IE2
	89	22	0,21	10,5	1692	2,1					
	116	18	0,22	8,0	1553	2,8					
	23	37	0,09	62	2778	0,7	EV040-3E71M/4C	0,67	9,2	72	IE3
	29	50	0,15	50	2411	0,8	EV040-2E71M/4B	0,71	8,3		IE2
	34	45	0,16	42	2295	0,9					
	45	38	0,18	32	2118	1,0					
	57	31	0,19	25	1972	1,3					
	68	27	0,19	21	1884	1,5					
	90	21	0,20	16	1741	1,9					
	120	17	0,21	12	1595	2,7					
	137	15	0,21	10,5	1533	2,7					
	179	12	0,22	8,0	1406	3,6					
0,37 0,50	1,2	1009	0,13	1189	13000	1,2	EV125-E063-3E71M/4D	0,97	76,2	106	IE3
	1,6	819	0,14	884,5	13000	1,4	EV125-E063-2E71M/4C	1,00	75,4		IE2
	1,9	759	0,15	739,5	13000	1,5					
	2,5	607	0,16	565,5	13000	1,9					
	3,4	474	0,17	420,5	13000	2,3					
	3,9	443	0,18	369,75	13000	2,5					
	5,1	363	0,19	282,75	13000	3,0					
	1,5	831	0,13	930	8200	0,8	EV100-E050-3E71M/4D	0,97	43,4	105	IE3
	1,9	724	0,15	750	8200	0,9	EV100-E050-2E71M/4C	1,00	42,6		IE2
	2,5	592	0,16	570	8200	1,1					
	3,3	479	0,17	435	8200	1,3					
	3,8	442	0,18	375	8200	1,4					
	5,0	353	0,19	285	8200	1,7					
	6,6	313	0,22	217,5	8200	2,1					
	8,0	263	0,22	180	8200	2,4					
	3,1	476	0,15	469,35	8200	0,7	EV100-NR11-3E71M/4D	0,97	49,3	111	IE3
	3,7	495	0,19	387,4	8200	0,9	EV100-NR11-2E71M/4C	1,00	48,5		IE2
	4,8	395	0,20	298	8200	1,3					
	6,4	325	0,22	223,5	8200	1,7					
	7,4	325	0,25	193,7	8200	2,0					
	10	254	0,26	149	8200	2,9					
	8,7	216	0,20	107	8200	0,9	EV100-3E80M/6B	1,03	41,5	92	IE3
	11	184	0,22	82	8200	1,8	EV100-2E80M/6A	1,08	40,8		IE2
	15	148	0,23	63	8200	3,4					
3,8	435	0,17	375	7400	0,8	EV080-E040-3E71M/4D	0,97	21,0	104	IE3	
4,6	372	0,18	315	7400	0,9	EV080-E040-2E71M/4C	1,00	20,2		IE2	
6,0	298	0,19	240	7400	1,1						
8,0	260	0,22	180	7400	1,4						
6,4	298	0,20	223,5	7400	1,0	EV080-NR11-3E71M/4D	0,97	28,6	110	IE3	
7,3	326	0,25	197,43	7400	0,8	EV080-NR11-2E71M/4C	1,00	27,8		IE2	
9,6	248	0,25	149	7400	1,3						
13	190	0,26	111,75	7400	1,8						

\*: IE2 ve IE3 motorlu redüktör fiyatları farklıdır. / Geared motor prices are different for IE2 and IE3 motors. / Preise von Getrieben mit IE2 und IE3 Motoren sind unterschiedlich.

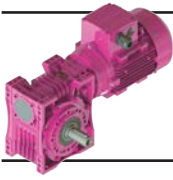

# E Serisi Motorlu Güç Devir Sayfaları

## E Series Geared Motors Performance Tables

### E Serien Getriebemotoren Leistung und Drehzahlübersicht

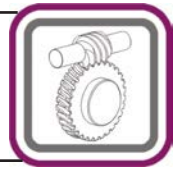

Güç Power Leistung P <sub>g</sub> [kW] P <sub>g</sub> [HP]	IE3	IE3	IE3	Çevrim Oranı Übersetzung i	IE3	IE3	Tipi Type Typ	Anma Akımı Rated Current Nennstrom [A]	Ağırlık Weight Gewicht ~ [kg]	Ölçü Sayfası Dim. Page Maß Seite	Motor*
	Çıkış Devri Output Speeds Abtriebswelle Drehzahlen n <sub>2</sub> [r.p.m]	Çıkış Momenti Output Torque Abtriebswelle Drehmomente M <sub>2</sub> [Nm]	Çıkış Gücü Output Power Abtriebswelle Leistung P <sub>2</sub> [kW]		Güv. Rad. Yük Çıkış Per.O. Loads (Output) Zul. Querkräfte (Abtrieb) F <sub>qam</sub> [N]	Servis Faktörü Service Factors Betriebsfaktor f <sub>s</sub>					Motor Verim Snf. Motor Eff. Class
0,37 0,50	11	167	0,20	82	7400	0,9	EV080-3E80M/6B	1,03	28,6	88	IE3
	15	137	0,22	62	7400	1,8	EV080-2E80M/6A	1,08	27,9		IE2
	18	129	0,24	53	7400	1,9					
	23	104	0,25	40	7395	2,9					
	5	396	0,19	315	7000	0,7	EV075-E040-3E71M/4D	0,97	19,7	103	IE3
	6	317	0,20	240	7000	0,8	EV075-E040-2E71M/4C	1,00	18,9		IE2
	8	245	0,20	180	7000	1,0					
	8	298	0,24	186,25	7000	0,8	EV075-NR11-3E71M/4D	0,97	20,7	109	IE3
	10	251	0,25	149	7000	1,0	EV075-NR11-2E71M/4C	1,00	19,9		IE2
	13	199	0,27	111,75	7000	1,3					
	9	180	0,18	100	7000	0,9	EV075-3E80M/6B	1,03	21,7	84	IE3
	12	163	0,20	80	7000	1,2	EV075-2E80M/6A	1,08	21,0		IE2
	16	129	0,21	60	7000	1,6					
	19	120	0,23	50	7000	1,9					
	23	102	0,25	40	7000	2,3					
	31	80	0,26	30	7000	3,1					
	37	71	0,28	25	7000	3,3					
	11	153	0,18	82	6200	0,7	EV063-3E80M/6B	1,03	16,2	80	IE3
	15	124	0,20	61	6200	1,0	EV063-2E80M/6A	1,08	15,5		IE2
	18	119	0,23	51	5970	1,0					
	24	95	0,24	39	5510	1,4					
	32	75	0,25	29	5012	2,1					
	36	72	0,27	25,5	4841	1,8					
	48	59	0,29	19,5	4447	2,4					
	64	45	0,30	14,5	4065	3,6					
	14	119	0,18	100	6200	0,7	EV063-3E71M/4D	0,97	14,0	80	IE3
	18	110	0,20	82	6180	0,9	EV063-2E71M/4C	1,00	13,2		IE2
	24	90	0,22	61	5618	1,3					
	28	83	0,24	51	5325	1,3					
	37	67	0,26	39	4903	1,9					
	49	52	0,27	29	4464	2,7					
	56	49	0,29	25,5	4316	2,4					
	74	40	0,31	19,5	3958	3,1					
	24	89	0,23	38	3644	0,8	EV050-3E80M/6B	1,03	13,9	76	IE3
	32	72	0,24	29	3361	1,1	EV050-2E80M/6A	1,08	13,2		IE2
	37	69	0,27	25	3235	1,2					
	49	55	0,28	19	2979	1,4					
	64	43	0,29	14,5	2754	1,9					
	78	37	0,30	12	2609	2,2					
	98	31	0,31	9,5	2434	2,4					
	128	24	0,32	7,25	2248	3,3					
	23	88	0,21	62	3796	0,7	EV050-3E71M/4D	0,97	11,7	76	IE3
	29	77	0,23	50	3592	0,8	EV050-2E71M/4C	1,00	10,9		IE2
	38	63	0,25	38	3296	1,1					

\*: IE2 ve IE3 motorlu redüktör fiyatları farklıdır. / Geared motor prices are different for IE2 and IE3 motors. / Preise von Getrieben mit IE2 und IE3 Motoren sind unterschiedlich.



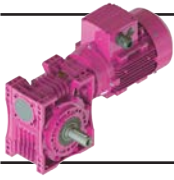

# E Serisi Motorlu Güç Devir Sayfaları

## E Series Geared Motors Performance Tables

### E Serien Getriebemotoren Leistung und Drehzahlübersicht

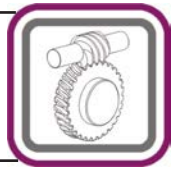

Güç	IE3 Çıkış Devri	IE3 Çıkış Momenti	IE3 Çıkış Gücü	Çevrim Oranı	IE3 Güv. Rad. Yük Çıkış	IE3 Servis Faktörü	Tipi	Anma Akımı	Ağırlık	Ölçü Sayfası	Motor Verim Sınıfı*
Power	Output Speeds	Output Torque	Output Power	Ratio	Per.O. Loads (Output)	Service Factors	Type	Rated Current	Weight	Dim. Page	Motor Eff. Class
Leistung	Abtriebswelle Drehzahlen	Abtriebswelle Drehmomente	Abtriebswelle Leistung	Übersetzung	Zul.Querkräfte (Abtrieb)	Betriebsfaktor	Typ	Nennstrom	Gewicht ~	Maß Seite	Motor Effizienz-klasse
P <sub>g</sub> [kW] P <sub>g</sub> [HP]	n <sub>2</sub> [r.p.m]	M <sub>2</sub> [Nm]	P2 [kW]	i	F <sub>qam</sub> [N]	f <sub>s</sub>		[A]	[kg]		
0,37 0,50	49	51	0,26	29	3030	1,5	EV050-3E71M/4D	0,97	11,7	76	IE3
	57	47	0,28	25	2931	1,5	EV050-2E71M/4C	1,00	10,9		IE2
	76	37	0,30	19	2691	1,8					
	99	29	0,30	14,5	2482	2,5					
	120	25	0,31	12	2348	2,8					
	151	20	0,32	9,5	2189	3,1					
	198	16	0,33	7,25	2016	4,2					
	57	46	0,28	25	1793	0,9	EV040-3E71M/4D	0,97	10,0	72	IE3
	68	40	0,28	21	1727	1,0	EV040-2E71M/4C	1,00	9,2		IE2
	90	32	0,30	16	1607	1,3					
	120	25	0,31	12	1480	1,8					
	137	22	0,31	10,5	1426	1,8					
	179	17	0,32	8,0	1310	2,4					
	0,55 0,75	1,2	1514	0,19	1189	13000	0,8	EV125-E063-3E80M/4C	1,34	78,0	106
1,6		1204	0,21	884,5	13000	1,0	EV125-E063-2E80M/4B	1,45	77,2		IE2
2,0		1133	0,23	739,5	13000	1,0					
2,6		893	0,24	565,5	13000	1,3					
3,4		698	0,25	420,5	13000	1,6					
3,9		652	0,27	369,75	13000	1,7					
5,1		603	0,32	282,75	13000	2,0					
6,9		459	0,33	210,25	13000	2,6					
7,8		414	0,34	184,88	13000	2,8					
4,8		544	0,28	299,46	13000	1,4	EV125-NR21-3E80M/4C	1,34	90,8	112	IE3
5,8		551	0,33	251,16	13000	1,4	EV125-NR21-2E80M/4B	1,45	90,0		IE2
7,5		434	0,34	193,2	13000	2,0					
10		322	0,35	140,07	13000	3,2					
12		335	0,41	125,58	13000	2,6					
3,3		705	0,25	435	8200	0,9	EV100-E050-3E80M/4C	1,34	46,4	105	IE3
3,9		656	0,27	375	8200	0,9	EV100-E050-2E80M/4B	1,45	45,6		IE2
5,1		520	0,28	285	8200	1,1					
6,7		460	0,32	217,5	8200	1,4					
8,1		386	0,33	180	8200	1,6					
4,9		580	0,30	298	8200	0,8	EV100-NR11-3E80M/4C	1,34	52,3	111	IE3
6,5		479	0,33	223,5	8200	1,2	EV100-NR11-2E80M/4B	1,45	51,5		IE2
7,5		477	0,37	193,7	8200	1,4					
10		374	0,38	149	8200	1,9					
8,7		320	0,29	107	8200	0,6	EV100-3E80M/6C	1,47	42,4	92	IE3
11		272	0,32	82	8200	1,2	EV100-2E80M/6B	1,50	41,7		IE2
15		219	0,34	63	8200	2,3					
18		195	0,37	52	8200	2,4					
23		159	0,39	40	8200	3,3					
14		231	0,33	107	8200	0,9	EV100-3E80M/4C	1,34	42,3	92	IE3
18		191	0,35	82	8200	1,7	EV100-2E80M/4B	1,45	41,5		IE2
23		149	0,36	63	8200	3,0					
28		133	0,39	52	8200	3,1					

\*: IE2 ve IE3 motorlu redüktör fiyatları farklıdır. / Geared motor prices are different for IE2 and IE3 motors. / Preise von Getrieben mit IE2 und IE3 Motoren sind unterschiedlich.

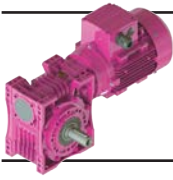

# E Serisi Motorlu Güç Devir Sayfaları

## E Series Geared Motors Performance Tables

### E Serien Getriebemotoren Leistung und Drehzahlübersicht

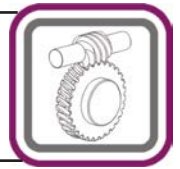

Güç	IE3 Çıkış Devri	IE3 Çıkış Momenti	IE3 Çıkış Gücü	Çevrim Oranı	IE3 Güv. Rad. Yük Çıkış	IE3 Servis Faktörü	Tipi	Anma Akımı	Ağırlık	Ölçü Sayfası	Motor Verim Snf.*
Power	Output Speeds	Output Torque	Output Power	Ratio	Per.O. Loads (Output)	Service Factors	Type	Rated Current	Weight	Dim. Page	Motor Eff. Class
Leistung	Abtriebswelle Drehzahlen	Abtriebswelle Drehmomente	Abtriebswelle Leistung	Übersetzung	Zul. Querkräfte (Abtrieb)	Betriebsfaktor	Typ	Nennstrom	Gewicht ~	Maß Seite	Motor Effizienzklasse
P <sub>g</sub> [kW] P <sub>g</sub> [HP]	n <sub>2</sub> [r.p.m]	M <sub>2</sub> [Nm]	P2 [kW]	i	F <sub>qam</sub> [N]	f <sub>s</sub>		[A]	[kg]		
0,55 0,75	15	203	0,32	62	7400	1,2	EV080-3E80M/6C	1,47	21,7	88	IE3
	18	193	0,36	53	7400	1,3	EV080-2E80M/6B	1,50	21,0		IE2
	23	153	0,38	40	7078	1,9					
	31	121	0,39	30	6471	2,7					
	35	113	0,42	26,5	6268	2,4					
	47	89	0,43	20	5747	3,4					
	18	178	0,33	82	7400	0,9	EV080-3E80M/4C	1,34	21,6	88	IE3
	23	142	0,35	62	7169	1,7	EV080-2E80M/4B	1,45	20,8		IE2
	27	133	0,38	53	6859	1,7					
	36	106	0,40	40	6279	2,5					
16	191	0,31	60	7000	1,1	EV075-3E80M/6C	1,47	21,2	84	IE3	
	178	0,35	50	7000	1,3	EV075-2E80M/6B	1,50	20,5		IE2	
	23	151	0,37	40	7000	1,5					
	31	119	0,39	30	7000	2,1					
	37	105	0,41	25	7000	2,2					
	47	88	0,43	20	7000	2,7					
	62	70	0,45	15	6895	3,5					
	15	198	0,30	100	7000	0,9	EV075-3E80M/4C	1,34	22,0	84	IE3
18	173	0,33	80	7000	1,1	EV075-2E80M/4B	1,45	21,2		IE2	
24	134	0,34	60	7000	1,5						
29	123	0,37	50	7000	1,6						
36	104	0,40	40	7000	2,0						
48	81	0,41	30	7000	2,7						
58	71	0,43	25	7000	2,9						
15	183	0,29	61	5815	0,7	EV063-3E80M/6C	1,47	17,1	80	IE3	
	178	0,34	51	5476	0,7	EV063-2E80M/6B	1,50	16,4		IE2	
	24	142	0,36	39	5085	1,0					
	32	111	0,37	29	4652	1,4					
	37	106	0,41	25,5	4515	1,2					
	48	87	0,44	19,5	4158	1,6					
	64	66	0,45	14,5	3821	2,4					
	73	61	0,46	12,75	3670	2,1					
	96	47	0,47	9,75	3406	2,9					
	24	132	0,33	61	5243	0,9	EV063-3E80M/4C	1,34	17,0	80	IE3
28	124	0,37	51	4973	0,9	EV063-2E80M/4B	1,45	16,2		IE2	
37	98	0,38	39	4610	1,3						
50	76	0,40	29	4209	1,9						
57	71	0,43	25,5	4089	1,6						
74	59	0,46	19,5	3757	2,1						
100	45	0,47	14,5	3441	3,1						
32	108	0,36	29	2971	0,8	EV050-3E80M/6C	1,47	14,8	76	IE3	
	102	0,40	25	2896	0,8	EV050-2E80M/6B	1,50	14,1		IE2	
	49	81	0,42	19	2682	1,0					
	64	64	0,43	14,5	2498	1,3					
	78	54	0,44	12	2380	1,5					
	98	45	0,46	9,5	2231	1,6					
	129	35	0,47	7,25	2075	2,2					

\*: IE2 ve IE3 motorlu redüktör fiyatları farklıdır. / Geared motor prices are different for IE2 and IE3 motors. / Preise von Getrieben mit IE2 und IE3 Motoren sind unterschiedlich.

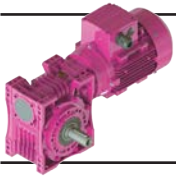

# E Serisi Motorlu Güç Devir Sayfaları

## E Series Geared Motors Performance Tables

### E Serien Getriebemotoren Leistung und Drehzahlübersicht

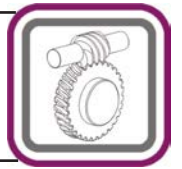

Güç Power Leistung P <sub>g</sub> [kW] P <sub>g</sub> [HP]	IE3 Çıkış Devri Output Speeds Abtriebswelle Drehzahlen n <sub>2</sub> [r.p.m]	IE3 Çıkış Momenti Output Torque Abtriebswelle Drehmomente M <sub>2</sub> [Nm]	IE3 Çıkış Gücü Output Power Abtriebswelle Leistung P2 [kW]	Çevrim Oranı Ratio Übersetzung i	IE3 Güv. Rad. Yük Çıkış Per.O. Loads (Output) Zul.Querkräfte (Abtrieb) F <sub>qam</sub> [N]	IE3 Servis Faktörü Service Factors Betriebsfaktor f <sub>s</sub>	Tipi Type Typ	Anma Akımı Rated Current Nennstrom [A]	Ağırlık Weight Gewicht ~ [kg]	Ölçü Sayfası Dim. Page Maß Seite	Motor Verim Sınıfı Motor Eff. Class Motor Effizienzklasse
0,55 0,75	38	94	0,37	38	2981	0,7	EV050-3E80M/4C	1,34	14,7	76	IE3
	50	75	0,39	29	2763	1,0	EV050-2E80M/4B	1,45	13,9		IE2
	58	69	0,42	25	2692	1,0					
	76	55	0,44	19	2486	1,2					
	100	43	0,45	14,5	2306	1,7					
	121	36	0,46	12	2192	1,9					
	153	30	0,48	9,5	2050	2,1					
	200	23	0,49	7,25	1898	2,9					
0,75 1,0	2,6	1218	0,33	565,5	13000	0,9	EV125-E063-3E80M/4D	1,77	80,3	106	IE3
	3,4	952	0,34	420,5	13000	1,2	EV125-E063-2E80M/4C	1,89	79,2		IE2
	3,9	889	0,37	369,75	13000	1,2					
	3,8	1113	0,44	282,75	13000	1,5					
	6,9	625	0,45	210,25	13000	1,9					
	7,8	564	0,46	184,88	13000	2,1					
	4,8	742	0,38	299,46	13000	1,0	EV125-NR21-3E80M/4D	1,77	91,9	112	IE3
	5,8	751	0,45	251,16	13000	1,0	EV125-NR21-2E80M/4C	1,89	90,8		IE2
	7,5	592	0,47	193,2	13000	1,5					
	10	440	0,48	140,07	13000	2,3					
	12	457	0,55	125,58	13000	1,9					
	8,8	479	0,44	107	13000	0,9	EV125-3E90S/6B	1,96	77,1	96	IE3
	11	393	0,47	83	13000	1,7	EV125-2E90S/6A	2,00	75,8		IE2
	15	307	0,49	62	13000	3,1					
	18	287	0,55	52	13000	2,9					
	5,1	709	0,38	285	8200	0,8	EV100-E050-3E80M/4D	1,77	47,5	105	IE3
	6,7	627	0,44	217,5	8200	1,0	EV100-E050-2E80M/4C	1,89	46,4		IE2
	8,1	527	0,44	180	8200	1,2					
	7,5	651	0,51	193,7	8200	0,9	EV100-NR11-3E80M/4D	1,77	53,4	111	IE3
	10	510	0,52	149	8200	1,4	EV100-NR11-2E80M/4C	1,89	52,3		IE2
	12	367	0,44	82	8200	0,9	EV100-3E90S/6B	1,96	46,6	92	IE3
	15	299	0,47	63	8200	1,7	EV100-2E90S/6A	2,00	45,3		IE2
	18	263	0,50	52	8200	1,8					
	24	214	0,53	40	8200	2,4					
32	172	0,57	30	8200	3,5						
18	260	0,48	82	8200	1,2	EV100-3E80M/4D	1,77	43,4	92	IE3	
23	203	0,49	63	8200	2,2	EV100-2E80M/4C	1,89	42,3		IE2	
28	182	0,53	52	8200	2,3						
36	144	0,55	40	8200	3,1						
48	113	0,57	30	8044	4,4						
56	107	0,63	26	7697	3,8						
15	274	0,44	62	7400	0,9	EV080-3E90S/6B	1,96	25,9	88	IE3	
18	260	0,49	53	7313	1,0	EV080-2E90S/6A	2,00	24,6		IE2	
24	207	0,51	40	6722	1,4						
32	163	0,54	30	6162	2,0						
36	152	0,57	26,5	5992	1,7						

\*: IE2 ve IE3 motorlu redüktör fiyatları farklıdır. / Geared motor prices are different for IE2 and IE3 motors. / Preise von Getrieben mit IE2 und IE3 Motoren sind unterschiedlich.

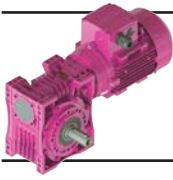

# E Serisi Motorlu Güç Devir Sayfaları

## E Series Geared Motors Performance Tables

### E Serien Getriebemotoren Leistung und Drehzahlübersicht

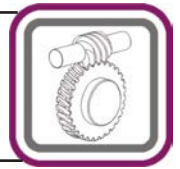

Güç	IE3 Çıkış Devri	IE3 Çıkış Momenti	IE3 Çıkış Gücü	Çevrim Oranı	IE3 Güv. Rad. Yük Çıkış	IE3 Servis Faktörü	Tipi	Anma Akımı	Ağırlık	Ölçü Sayfası	Motor Verim Snf.*
Power	Output Speeds	Output Torque	Output Power	Ratio	Per.O. Loads (Output)	Service Factors	Type	Rated Current	Weight	Dim. Page	Motor Eff. Class
Leistung P <sub>g</sub> [kW] P <sub>g</sub> [HP]	Abtriebswelle Drehzahlen n <sub>2</sub> [r.p.m]	Abtriebswelle Drehmomente M <sub>2</sub> [Nm]	Abtriebswelle Leistung P2 [kW]	Übersetzung i	Zul.Querkräfte (Abtrieb) F <sub>qam</sub> [N]	Betriebsfaktor f <sub>s</sub>	Typ	Nennstrom [A]	Gewicht ~ [kg]	Maß Seite	Motor Effizienz- klasse
0,75 1,0	47	120	0,59	20	5511	2,5	EV080-3E90S/6B	1,96	25,9	88	IE3
	63	94	0,62	15	5044	3,5	EV080-2E90S/6A	2,00	24,6		IE2
	23	193	0,47	62	6862	1,3	EV080-3E80M/4D	1,77	22,7	88	IE3
	27	182	0,52	53	6587	1,3	EV080-2E80M/4C	1,89	21,6		IE2
	36	144	0,55	40	6044	1,8					
	48	110	0,56	30	5551	2,6					
	55	102	0,59	26,5	5383	2,2					
	73	80	0,61	20	4938	3,2					
	16	257	0,42	60	7000	0,8	EV075-3E90S/6B	1,96	25,5	84	IE3
	19	240	0,47	50	7000	0,9	EV075-2E90S/6A	2,00	24,2		IE2
	24	204	0,51	40	7000	1,1					
	32	160	0,53	30	7000	1,5					
	38	142	0,56	25	7000	1,7					
	47	119	0,59	20	7000	2,0					
	63	94	0,62	15	6585	2,6					
	18	235	0,45	80	7000	0,8	EV075-3E80M/4D	1,77	22,0	84	IE3
	24	182	0,46	60	7000	1,1	EV075-2E80M/4C	1,89	20,9		IE2
	29	167	0,51	50	7000	1,2					
	36	142	0,54	40	7000	1,5					
	48	110	0,56	30	7000	2,0					
	58	96	0,58	25	6904	2,1					
	73	80	0,61	20	6460	2,6					
	97	63	0,63	15	5928	3,3					
	24	191	0,49	39	4629	0,7	EV063-3E90S/6B	1,96	21,3	80	IE3
	33	150	0,51	29	4255	1,1	EV063-2E90S/6A	2,00	20,0		IE2
	37	144	0,56	25,5	4153	0,9					
	48	117	0,59	19,5	3838	1,2					
	65	89	0,61	14,5	3550	1,8					
	74	82	0,63	12,75	3413	1,5					
	97	63	0,64	9,75	3185	2,1					
	130	49	0,67	7,25	2935	3,1					
	37	133	0,52	39	4298	0,9	EV063-3E80M/4D	1,77	18,1	80	IE3
	50	104	0,55	29	3938	1,4	EV063-2E80M/4C	1,89	17,0		IE2
	57	97	0,58	25,5	3851	1,2					
	74	80	0,62	19,5	3545	1,5					
	100	61	0,64	14,5	3263	2,3					
	114	55	0,65	12,75	3143	1,9					
	149	42	0,66	9,75	2922	2,7					
	50	110	0,57	19	2356	0,7	EV050-3E90S/6B	1,96	19,0	76	IE3
	65	87	0,59	14,5	2216	1,0	EV050-2E90S/6A	2,00	17,7		IE2
	79	73	0,60	12	2129	1,1					
	99	61	0,63	9,5	2009	1,2					
130	48	0,65	7,25	1881	1,7						
	50	102	0,53	29	2473	0,7	EV050-3E80M/4D	1,77	15,8	76	IE3
	58	95	0,58	25	2439	0,7	EV050-2E80M/4C	1,89	14,7		IE2
	76	75	0,60	19	2266	0,9					

\*: IE2 ve IE3 motorlu redüktör fiyatları farklıdır. / Geared motor prices are different for IE2 and IE3 motors. / Preise von Getrieben mit IE2 und IE3 Motoren sind unterschiedlich.

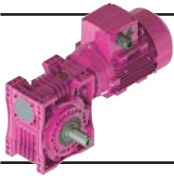

# E Serisi Motorlu Güç Devir Sayfaları

## E Series Geared Motors Performance Tables

### E Serien Getriebemotoren Leistung und Drehzahlübersicht

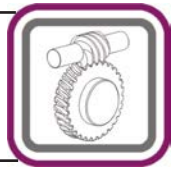

Güç	IE3 Çıkış Devri	IE3 Çıkış Momenti	IE3 Çıkış Gücü	Çevrim Oranı	IE3 Güv. Rad. Yük Çıkış	IE3 Servis Faktörü	Tipi	Anma Akımı	Ağırlık	Ölçü Sayfası	Motor Verim Snf.*
Power	Output Speeds	Output Torque	Output Power	Ratio	Per.O. Loads (Output)	Service Factors	Type	Rated Current	Weight	Dim. Page	Motor Eff. Class
Leistung P <sub>g</sub> [kW] P <sub>g</sub> [HP]	Abtriebswelle Drehzahlen n <sub>2</sub> [r.p.m]	Abtriebswelle Drehmomente M <sub>2</sub> [Nm]	Abtriebswelle Leistung P <sub>2</sub> [kW]	Übersetzung i	Zul.Querkräfte (Abtrieb) F <sub>qam</sub> [N]	Betriebsfaktor f <sub>s</sub>	Typ	Nennstrom [A]	Gewicht ~ [kg]	Maß Seite	Motor Effizienz- klasse
<b>0,75</b> 1,0	100	59	0,62	<b>14,5</b>	2117	1,2	<b>EV050-3E80M/4D</b>	1,77	15,8	76	IE3
	121	49	0,63	<b>12</b>	2024	1,4	<b>EV050-2E80M/4C</b>	1,89	14,7		IE2
	153	41	0,65	<b>9,5</b>	1903	1,5					
	200	32	0,66	<b>7,25</b>	1773	2,1					
<b>1,1</b> 1,5	3,4	1396	0,50	<b>420,5</b>	13000	0,8	<b>EV125-E063-3E90S/4C</b>	2,46	78,6	106	IE3
	3,9	1304	0,54	<b>369,75</b>	13000	0,8	<b>EV125-E063-2E90S/4B</b>	2,60	76,7		IE2
	5,1	1206	0,65	<b>282,75</b>	13000	1,0					
	6,9	917	0,66	<b>210,25</b>	13000	1,3					
	7,8	827	0,68	<b>184,88</b>	13000	1,4					
	7,5	868	0,68	<b>193,2</b>	13000	1,0	<b>EV125-NR21-3E90S/4C</b>	2,46	96,6	112	IE3
	10	645	0,70	<b>140,07</b>	13000	1,6	<b>EV125-NR21-2E90S/4B</b>	2,60	94,7		IE2
	12	671	0,81	<b>125,58</b>	13000	1,3					
	8,8	706	0,65	<b>107</b>	13000	0,6	<b>EV125-3E90L/6C</b>	2,75	79,6	96	IE3
	11	574	0,68	<b>83</b>	13000	1,2	<b>EV125-2E90L/6B</b>	2,90	77,4		IE2
	15	453	0,72	<b>62</b>	13000	2,1					
	18	424	0,80	<b>52</b>	13000	2,0					
	24	337	0,83	<b>40</b>	12396	2,9					
	6,7	920	0,64	<b>217,5</b>	8200	0,7	<b>EV100-E050-3E90S/4C</b>	2,46	52,2	105	IE3
	8,1	772	0,65	<b>180</b>	8200	0,8	<b>EV100-E050-2E90S/4B</b>	2,60	50,3		IE2
	15	436	0,68	<b>63</b>	8200	1,1	<b>EV100-3E90L/6C</b>	2,75	49,1	92	IE3
	18	387	0,73	<b>52</b>	8200	1,2	<b>EV100-2E90L/6B</b>	2,90	46,9		IE2
	24	316	0,78	<b>40</b>	8200	1,7					
	31	253	0,83	<b>30</b>	8200	2,3					
	36	234	0,88	<b>26</b>	8200	2,0					
	47	186	0,92	<b>20</b>	7701	2,8					
	18	381	0,71	<b>82</b>	8200	0,8	<b>EV100-3E90S/4C</b>	2,46	48,1	92	IE3
	23	297	0,72	<b>63</b>	8200	1,5	<b>EV100-2E90S/4B</b>	2,60	46,2		IE2
	28	267	0,78	<b>52</b>	8200	1,6					
	36	212	0,80	<b>40</b>	8200	2,1					
	48	165	0,84	<b>30</b>	7755	3,0					
	24	305	0,75	<b>40</b>	6136	1,0	<b>EV080-3E90L/6C</b>	2,75	28,4	88	IE3
	31	241	0,79	<b>30</b>	5656	1,4	<b>EV080-2E90L/6B</b>	2,90	26,2		IE2
35	224	0,83	<b>26,5</b>	5543	1,2						
47	176	0,87	<b>20</b>	5129	1,7						
63	139	0,91	<b>15</b>	4715	2,4						
71	127	0,94	<b>13,25</b>	4527	2,0						
94	98	0,97	<b>10</b>	4197	2,9						
23	284	0,69	<b>62</b>	6324	0,9	<b>EV080-3E90S/4C</b>	2,46	27,4	88	IE3	
27	267	0,76	<b>53</b>	6111	0,9	<b>EV080-2E90S/4B</b>	2,60	25,5		IE2	
36	211	0,80	<b>40</b>	5633	1,3						
48	162	0,82	<b>30</b>	5205	1,8						
55	150	0,86	<b>26,5</b>	5078	1,5						
73	118	0,90	<b>20</b>	4678	2,2						
97	91	0,92	<b>15</b>	4299	3,0						

\*: IE2 ve IE3 motorlu redüktör fiyatları farklıdır. / Geared motor prices are different for IE2 and IE3 motors. / Preise von Getrieben mit IE2 und IE3 Motoren sind unterschiedlich.

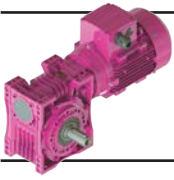

# E Serisi Motorlu Güç Devir Sayfaları

## E Series Geared Motors Performance Tables

### E Serien Getriebemotoren Leistung und Drehzahlübersicht

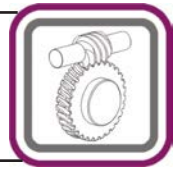

Güç	IE3 Çıkış Devri	IE3 Çıkış Momenti	IE3 Çıkış Gücü	Çevrim Oranı	IE3 Güv. Rad. Yük Çıkış	IE3 Servis Faktörü	Tipi	Anma Akımı	Ağırlık	Ölçü Sayfası	Motor Verim Snf.*
Power	Output Speeds	Output Torque	Output Power	Ratio	Per.O. Loads (Output)	Service Factors	Type	Rated Current	Weight	Dim. Page	Motor Eff. Class
Leistung P <sub>g</sub> [kW] P <sub>g</sub> [HP]	Abtriebswelle Drehzahlen n <sub>2</sub> [r.p.m]	Abtriebswelle Drehmomente M <sub>2</sub> [Nm]	Abtriebswelle Leistung P2 [kW]	Übersetzung i	Zul.Querkräfte (Abtrieb) F <sub>qam</sub> [N]	Betriebsfaktor f <sub>s</sub>	Typ	Nennstrom [A]	Gewicht ~ [kg]	Maß Seite	Motor Effizienz-klasse
1,1 1,5	24	301	0,74	40	7000	0,8	EV075-3E90L/6C	2,75	26,7	84	IE3
	31	237	0,78	30	7000	1,0	EV075-2E90L/6B	2,90	24,5		IE2
	38	210	0,83	25	6965	1,1					
	47	176	0,87	20	6562	1,4					
	63	138	0,91	15	6080	1,8					
	94	97	0,95	10	5439	2,4					
	125	74	0,97	7,5	5012	3,0					
	24	267	0,68	60	7000	0,7	EV075-3E90S/4C	2,46	25,9	84	IE3
	29	245	0,75	50	7000	0,8	EV075-2E90S/4B	2,60	24,0		IE2
	36	209	0,79	40	7000	1,0					
	48	161	0,82	30	6759	1,4					
	58	141	0,86	25	6443	1,5					
	73	118	0,89	20	6056	1,8					
	97	92	0,93	15	5588	2,3					
	145	64	0,97	10	4969	3,1					
	48	173	0,87	19,5	3292	0,8	EV063-3E90L/6C	2,75	23,8	80	IE3
	65	132	0,89	14,5	3091	1,2	EV063-2E90L/6B	2,90	21,6		IE2
	74	120	0,93	12,75	2979	1,0					
	96	93	0,94	9,75	2824	1,4					
	130	72	0,98	7,25	2627	2,1					
	50	153	0,80	29	3464	0,9	EV063-3E90S/4C	2,46	22,8	80	IE3
	57	143	0,85	25,5	3433	0,8	EV063-2E90S/4B	2,60	20,9		IE2
	74	117	0,91	19,5	3174	1,1					
	100	89	0,93	14,5	2951	1,6					
114	80	0,96	12,75	2851	1,3						
149	62	0,96	9,75	2678	1,8						
200	47	0,99	7,25	2474	2,6						
78	108	0,88	12	1692	0,8	EV050-3E90L/6C	2,75	21,5	76	IE3	
99	90	0,93	9,5	1623	0,8	EV050-2E90L/6B	2,90	19,3		IE2	
130	70	0,95	7,25	1556	1,1						
100	86	0,90	14,5	1786	0,8	EV050-3E90S/4C	2,46	20,5	76	IE3	
121	72	0,92	12	1730	1,0	EV050-2E90S/4B	2,60	18,6		IE2	
153	60	0,96	9,5	1646	1,0						
200	46	0,97	7,25	1554	1,4						
1,5 2,0	6,9	1251	0,90	210,25	13000	0,9	EV125-E063-3E90L/4D	3,30	86,7	106	IE3
	7,8	1128	0,93	184,88	13000	1,0	EV125-E063-2E90L/4C	3,40	85,9		IE2
	10	879	0,95	140,07	13000	1,2	EV125-NR21-3E90L/4D	3,30	98,3	112	IE3
	12	915	1,11	125,58	13000	0,9	EV125-NR21-2E90L/4C	3,40	97,5		IE2
	12	778	0,94	83	13000	0,9	EV125-3E100L/6B	3,50	85,0	96	IE3
	15	608	0,98	62	13000	1,6	EV125-2E100L/6A	3,72	82,7		IE2
	18	573	1,10	52	12823	1,5					
	24	456	1,14	40	11858	2,1					
	33	331	1,14	29	10764	3,2					
	37	323	1,24	26	10487	2,6					
	48	257	1,28	20	9687	3,7					

\*: IE2 ve IE3 motorlu redüktör fiyatları farklıdır. / Geared motor prices are different for IE2 and IE3 motors. / Preise von Getrieben mit IE2 und IE3 Motoren sind unterschiedlich.

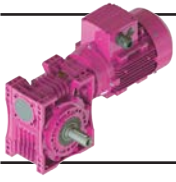

# E Serisi Motorlu Güç Devir Sayfaları

## E Series Geared Motors Performance Tables

### E Serien Getriebemotoren Leistung und Drehzahlübersicht

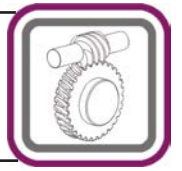

Güç	IE3 Çıkış Devri	IE3 Çıkış Momenti	IE3 Çıkış Gücü	Çevrim Oranı	IE3 Güv. Rad. Yük Çıkış	IE3 Servis Faktörü	Tipi	Anma Akımı	Ağırlık	Ölçü Sayfası	Motor Verim Sınıfı*
Power	Output Speeds	Output Torque	Output Power	Ratio	Per.O. Loads (Output)	Service Factors	Type	Rated Current	Weight	Dim. Page	Motor Eff. Class
Leistung P <sub>g</sub> [kW] P <sub>g</sub> [HP]	Abtriebswelle Drehzahlen n <sub>2</sub> [r.p.m]	Abtriebswelle Drehmomente M <sub>2</sub> [Nm]	Abtriebswelle Leistung P2 [kW]	Übersetzung i	Zul.Querkräfte (Abtrieb) F <sub>qam</sub> [N]	Betriebsfaktor f <sub>s</sub>	Typ	Nennstrom [A]	Gewicht ~ [kg]	Maß Seite	Motor Effizienz-klasse
1,5 2,0	15	591	0,94	63	8200	0,9	EV100-3E100L/6B	3,50	54,5	92	IE3
	18	520	1,00	52	8200	0,9	EV100-2E100L/6A	3,72	52,2		IE2
	24	426	1,07	40	8200	1,2					
	32	342	1,14	30	8075	1,7					
	37	316	1,22	26	7832	1,5					
	48	250	1,25	20	7297	2,1					
	64	193	1,28	15	6702	3,0					
	73	169	1,30	13	6431	2,6					
	96	133	1,33	10	5973	3,6					
	23	406	0,98	63	8200	1,1	EV100-3E90L/4D	3,30	49,8	92	IE3
	28	364	1,06	52	8200	1,1	EV100-2E90L/4C	3,40	49,0		IE2
	36	288	1,09	40	8113	1,6					
	48	225	1,14	30	7424	2,2					
	56	214	1,25	26	7133	1,9					
	73	167	1,27	20	6629	2,6					
	24	409	1,02	40	5456	0,7	EV080-3E100L/6B	3,50	33,8	92	IE3
	32	325	1,08	30	5051	1,0	EV080-2E100L/6A	3,72	31,5		IE2
	36	301	1,14	26,5	5016	0,9					
48	238	1,19	20	4665	1,3						
64	186	1,24	15	4324	1,8						
72	171	1,29	13,25	4146	1,5						
96	132	1,32	10	3882	2,1						
127	100	1,33	7,5	3612	2,6						
36	288	1,09	40	5163	0,9	EV080-3E90L/4D	3,30	29,1	88	IE3	
48	221	1,12	30	4810	1,3	EV080-2E90L/4C	3,40	28,3		IE2	
55	205	1,17	26,5	4730	1,1						
73	161	1,22	20	4381	1,6						
97	124	1,26	15	4047	2,2						
109	115	1,31	13,25	3878	1,9						
145	88	1,34	10	3604	2,7						
193	66	1,33	7,5	3340	3,8						
32	321	1,07	30	6397	0,8	EV075-3E100L/6B	3,50	33,4	84	IE3	
38	281	1,13	25	6178	0,8	EV075-2E100L/6A	3,72	31,1		IE2	
48	236	1,18	20	5865	1,0						
64	186	1,24	15	5488	1,3						
96	130	1,30	10	4966	1,8						
127	99	1,32	7,5	4606	2,2						
36	285	1,08	40	6502	0,7	EV075-3E90L/4D	3,30	25,5	84	IE3	
48	220	1,11	30	6166	1,0	EV075-2E90L/4C	3,40	24,7		IE2	
58	193	1,17	25	5914	1,1						
73	160	1,22	20	5593	1,3						
97	125	1,27	15	5200	1,7						
145	87	1,33	10	4662	2,2						
193	66	1,33	7,5	4309	2,8						
74	160	1,24	19,5	2749	0,8	EV063-3E90L/4D	3,30	24,5	80	IE3	
100	121	1,27	14,5	2594	1,1	EV063-2E90L/4C	3,40	23,7		IE2	
114	109	1,30	12,75	2518	1,0						

\*: IE2 ve IE3 motorlu redüktör fiyatları farklıdır. / Geared motor prices are different for IE2 and IE3 motors. / Preise von Getrieben mit IE2 und IE3 Motoren sind unterschiedlich.

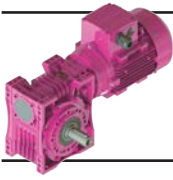

# E Serisi Motorlu Güç Devir Sayfaları

## E Series Geared Motors Performance Tables

### E Serien Getriebemotoren Leistung und Drehzahlübersicht

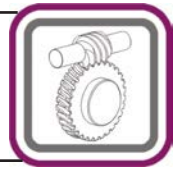

Güç	IE3 Çıkış Devri	IE3 Çıkış Momenti	IE3 Çıkış Gücü	Çevrim Oranı	IE3 Güv. Rad. Yük Çıkış	IE3 Servis Faktörü	Tipi	Anma Akımı	Ağırlık	Ölçü Sayfası	Motor Verim Snf.*
Power	Output Speeds	Output Torque	Output Power	Ratio	Per.O. Loads (Output)	Service Factors	Type	Rated Current	Weight	Dim. Page	Motor Eff. Class
Leistung P <sub>g</sub> [kW] P <sub>g</sub> [HP]	Abtriebswelle Drehzahlen n <sub>2</sub> [r.p.m]	Abtriebswelle Drehmomente M <sub>2</sub> [Nm]	Abtriebswelle Leistung P2 [kW]	Übersetzung i	Zul.Querkräfte (Abtrieb) F <sub>qam</sub> [N]	Betriebsfaktor f <sub>s</sub>	Typ	Nennstrom [A]	Gewicht ~ [kg]	Maß Seite	Motor Effizienz-klasse
1,5 2,0	149	84	1,31	9,75	2399	1,3	EV063-3E90L/4D	3,30	24,5	80	IE3
	200	65	1,36	7,25	2239	1,9	EV063-2E90L/4C	3,40	23,7		IE2
	153	82	1,30	9,5	1352	0,8	EV050-3E90L/4D	3,30	22,2	76	IE3
	200	63	1,33	7,25	1303	1,1	EV050-2E90L/4C	3,40	21,4		IE2
2,2 3,0	16	883	1,44	62	12348	1,1	EV125-3E112M/6B	4,95	91,9	96	IE3
	19	831	1,61	52	11835	1,0	EV125-2E112M/6A	5,32	89,7		IE2
	24	662	1,67	40	11003	1,5					
	33	480	1,67	29	10046	2,2					
	37	469	1,82	26	9843	1,8					
	48	373	1,88	20	9133	2,6					
	67	270	1,88	14,5	8315	3,9					
	17	784	1,43	83	12442	0,8	EV125-3E100L/4C	4,65	86,6	96	IE3
	23	587	1,44	62	11485	1,4	EV125-2E100L/4B	4,85	84,9		IE2
	28	573	1,67	52	10887	1,3					
	36	440	1,67	40	10145	1,9					
	50	319	1,67	29	9222	2,8					
	56	317	1,85	26	8975	2,3					
	73	248	1,88	20	8319	3,2					
	24	619	1,56	40	7869	0,8	EV100-3E112M/6B	4,95	61,4	92	IE3
	32	496	1,67	30	7190	1,2	EV100-2E112M/6A	5,32	59,2		IE2
	37	459	1,78	26	7047	1,0					
	48	362	1,83	20	6634	1,4					
64	280	1,88	15	6133	2,1						
74	245	1,91	13	5903	1,8						
97	193	1,95	10	5529	2,5						
129	147	1,98	7,5	5117	3,6						
28	534	1,56	52	7935	0,8	EV100-3E100L/4C	4,65	56,1	92	IE3	
36	423	1,61	40	7449	1,1	EV100-2E100L/4B	4,85	54,4		IE2	
48	330	1,67	30	6845	1,5						
56	315	1,84	26	6606	1,3						
73	245	1,86	20	6191	1,8						
97	186	1,88	15	5717	2,6						
112	165	1,93	13	5477	2,3						
145	129	1,95	10	5104	3,1						
193	97	1,97	7,5	4706	4,5						
48	346	1,75	20	3896	0,9	EV080-3E112M/6B	4,95	40,7	88	IE3	
64	270	1,82	15	3666	1,2	EV080-2E112M/6A	5,32	38,5		IE2	
73	248	1,89	13,25	3511	1,0						
97	192	1,94	10	3349	1,5						
129	145	1,95	7,5	3171	2,1						
48	324	1,64	30	4119	0,9	EV080-3E100L/4C	4,65	35,4	88	IE3	
55	300	1,72	26,5	4119	0,8	EV080-2E100L/4B	4,85	33,7		IE2	
73	236	1,79	20	3860	1,1						
97	182	1,85	15	3605	1,5						
109	168	1,93	13,25	3451	1,3						
145	129	1,96	10	3251	1,8						
193	97	1,96	7,5	3049	2,6						

\*: IE2 ve IE3 motorlu redüktör fiyatları farklıdır. / Geared motor prices are different for IE2 and IE3 motors. / Preise von Getrieben mit IE2 und IE3 Motoren sind unterschiedlich.



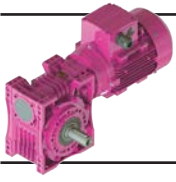

# E Serisi Motorlu Güç Devir Sayfaları

## E Series Geared Motors Performance Tables

### E Serien Getriebemotoren Leistung und Drehzahlübersicht

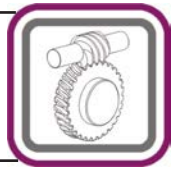

Güç Power Leistung P <sub>g</sub> [kW] P <sub>g</sub> [HP]	IE3	IE3	IE3	Çevrim Oranı Ratio Übersetzung i	IE3	IE3	Tipi Type Typ	Anma Akımı Rated Current Nennstrom [A]	Ağırlık Weight Gewicht ~ [kg]	Ölçü Sayfası Dim. Page Maß Seite	Motor*	
	Çıkış Devri Output Speeds Abtriebswelle Drehzahlen n <sub>2</sub> [r.p.m]	Çıkış Momenti Output Torque Abtriebswelle Drehmomente M <sub>2</sub> [Nm]	Çıkış Gücü Output Power Abtriebswelle Leistung P <sub>2</sub> [kW]		Güv. Rad. Yük Çıkış Per.O. Loads (Output) Zul.Querkräfte (Abtrieb) F <sub>qam</sub> [N]	Servis Faktörü Service Factors Betriebsfaktor f <sub>s</sub>					Motor Verim Snf. Motor Eff. Class Motor Effizienzklasse	
2,2 3,0	48	343	1,73	20	4676	0,7	EV075-3E112M/6B	4,95	36,7	84	IE3	
	64	269	1,82	15	4482	0,9	EV075-2E112M/6A	5,32	34,5		IE2	
	97	190	1,92	10	4153	1,2						
	129	144	1,94	7,5	3923	1,5						
	48	323	1,63	30	5125	0,7	EV075-3E100L/4C	4,65	34,1	84	IE3	
	58	282	1,72	25	4987	0,7	EV075-2E100L/4B	4,85	32,4		IE2	
	73	235	1,79	20	4781	0,9						
	97	183	1,86	15	4518	1,1						
	145	128	1,95	10	4123	1,5						
	193	97	1,96	7,5	3854	1,9						
	3,0 4,0	24	898	2,28	40	10053	1,1	EV125-3E132S/6B	6,55	113,7	96	IE3
		33	651	2,28	29	9251	1,6	EV125-2E132S/6A	6,85	109,2		IE2
		37	636	2,49	26	9131	1,3					
		49	506	2,57	20	8522	1,9					
67		367	2,57	14,5	7806	2,8						
75		340	2,65	13	7576	2,3						
97		266	2,70	10	7081	3,3						
23		801	1,96	62	10664	1,0	EV125-3E100L/4D	6,26	88,8	96	IE3	
28		781	2,28	52	10132	0,9	EV125-2E100L/4C	6,42	86,3		IE2	
36		601	2,28	40	9517	1,4						
50		435	2,28	29	8696	2,1						
56		433	2,53	26	8498	1,7						
73		338	2,57	20	7918	2,4						
100		245	2,57	14,5	7213	3,5						
112		228	2,67	13	6983	2,9						
145		177	2,69	10	6499	4,1						
36		577	2,19	40	6689	0,8	EV100-3E100L/4D	6,26	58,3	92	IE3	
48		450	2,28	30	6184	1,1	EV100-2E100L/4C	6,42	55,8		IE2	
56		429	2,50	26	6003	1,0						
73		334	2,54	20	5690	1,3						
97		254	2,57	15	5295	1,9						
112		225	2,63	13	5084	1,7						
145		175	2,66	10	4776	2,3						
193		133	2,69	7,5	4432	3,3						
73		322	2,44	20	3264	0,8	EV080-3E100L/4D	6,26	37,6	88	IE3	
97		249	2,52	15	3101	1,1	EV080-2E100L/4C	6,42	35,1		IE2	
109		229	2,63	13,25	2963	0,9						
145		176	2,68	10	2847	1,3						
193		132	2,67	7,5	2717	1,9						
97		250	2,53	15	3738	0,8	EV075-3E100L/4D	6,26	36,4	84	IE3	
145		175	2,65	10	3506	1,1	EV075-2E100L/4C	6,42	33,9		IE2	
193		132	2,67	7,5	3333	1,4						
4,0 5,5		24	1197	3,04	40	8878	0,8	EV125-3E132M/6C	8,52	114,6	96	IE3
		33	868	3,04	29	8269	1,2	EV125-2E132M/6B	8,80	109,6		IE2
		37	848	3,31	26	8254	1,0					

\*: IE2 ve IE3 motorlu redüktör fiyatları farklıdır. / Geared motor prices are different for IE2 and IE3 motors. / Preise von Getrieben mit IE2 und IE3 Motoren sind unterschiedlich.

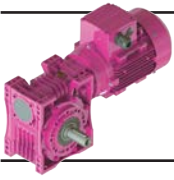

# E Serisi Motorlu Güç Devir Sayfaları

## E Series Geared Motors Performance Tables

### E Serien Getriebemotoren Leistung und Drehzahlübersicht

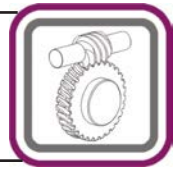

Güç	IE3 Çıkış Devri	IE3 Çıkış Momenti	IE3 Çıkış Gücü	Çevrim Oranı	IE3 Güv. Rad. Yük Çıkış	IE3 Servis Faktörü	Tipi	Anma Akımı	Ağırlık	Ölçü Sayfası	Motor Verim Snf.*
Power	Output Speeds	Output Torque	Output Power	Ratio	Per.O. Loads (Output) Zul.Querkräfte (Abtrieb)	Service Factors	Type	Rated Current	Weight	Dim. Page	Motor Eff. Class
Leistung P <sub>g</sub> [kW] P <sub>g</sub> [HP]	Abtriebswelle Drehzahlen n <sub>2</sub> [r.p.m]	Abtriebswelle Drehmomente M <sub>2</sub> [Nm]	Abtriebswelle Leistung P2 [kW]	Übersetzung i	F <sub>qam</sub> [N]	Betriebsfaktor f <sub>s</sub>	Typ	Nennstrom [A]	Gewicht ~ [kg]	Maß Seite	Motor Effizienz-klasse
4,0 5,5	49	674	3,42	20	7771	1,4	EV125-3E132M/6C	8,52	114,6	96	IE3
	67	489	3,43	14,5	7181	2,1	EV125-2E132M/6B	8,80	109,6		IE2
	75	453	3,54	13	6990	1,7					
	97	354	3,60	10	6590	2,5					
	134	260	3,65	7,25	6043	3,6					
	28	1034	3,04	52	9185	0,7	EV125-3E112M/4D	8,05	93,6	96	IE3
	37	795	3,04	40	8725	1,0	EV125-2E112M/4C	8,20	91,7		IE2
	50	577	3,04	29	8033	1,5					
	56	573	3,37	26	7894	1,3					
	73	448	3,42	20	7408	1,8					
	101	325	3,43	14,5	6787	2,7					
	112	302	3,55	13	6581	2,2					
	146	234	3,58	10	6164	3,1					
	201	176	3,72	7,25	5594	4,5					
	5,5 7,5	49	597	3,04	30	5360	0,8	EV100-3E112M/4D	8,05	67,8	92
56		568	3,34	26	5251	0,7	EV100-2E112M/4C	8,20	65,9		IE2
73		443	3,38	20	5063	1,0					
97		336	3,42	15	4767	1,4					
112		298	3,50	13	4591	1,3					
146		232	3,55	10	4363	1,7					
195		176	3,58	7,5	4087	2,5					
97		329	3,36	15	2476	0,8	EV080-3E112M/4D	8,05	47,1	88	IE3
110		304	3,51	13,25	2358	0,7	EV080-2E112M/4C	8,20	45,2		IE2
146		234	3,57	10	2345	1,0					
195		174	3,56	7,5	2304	1,4					
97		332	3,39	15	2757	0,6	EV075-3E112M/4D	8,05	45,6	84	IE3
146		231	3,54	10	2741	0,8	EV075-2E112M/4C	8,20	43,7		IE2
195		174	3,56	7,5	2688	1,1					
5,5 7,5		37	1094	4,18	40	7554	0,7	EV125-3E132S/4C	10,65	117,6	96
	50	793	4,18	29	7055	1,1	EV125-2E132S/4B	11,05	112,0		IE2
	56	788	4,63	26	7005	0,9					
	73	616	4,71	20	6659	1,3					
	101	447	4,71	14,5	6165	1,9					
	112	415	4,89	13	5994	1,6					
	146	322	4,93	10	5677	2,2					
	201	242	5,11	7,25	5177	3,3					
7,5 10	73	836	6,42	20	5664	0,9	EV125-3E132M/4D	14,40	121,7	96	IE3
	101	607	6,42	14,5	5336	1,4	EV125-2E132M/4C	15,00	117,0		IE2
	113	565	6,66	13	5213	1,2					
	147	438	6,72	10	5028	1,6					
	202	330	6,97	7,25	4622	2,4					

\*: IE2 ve IE3 motorlu redüktör fiyatları farklıdır. / Geared motor prices are different for IE2 and IE3 motors. / Preise von Getrieben mit IE2 und IE3 Motoren sind unterschiedlich.

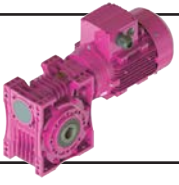

# Ölçü Sayfaları

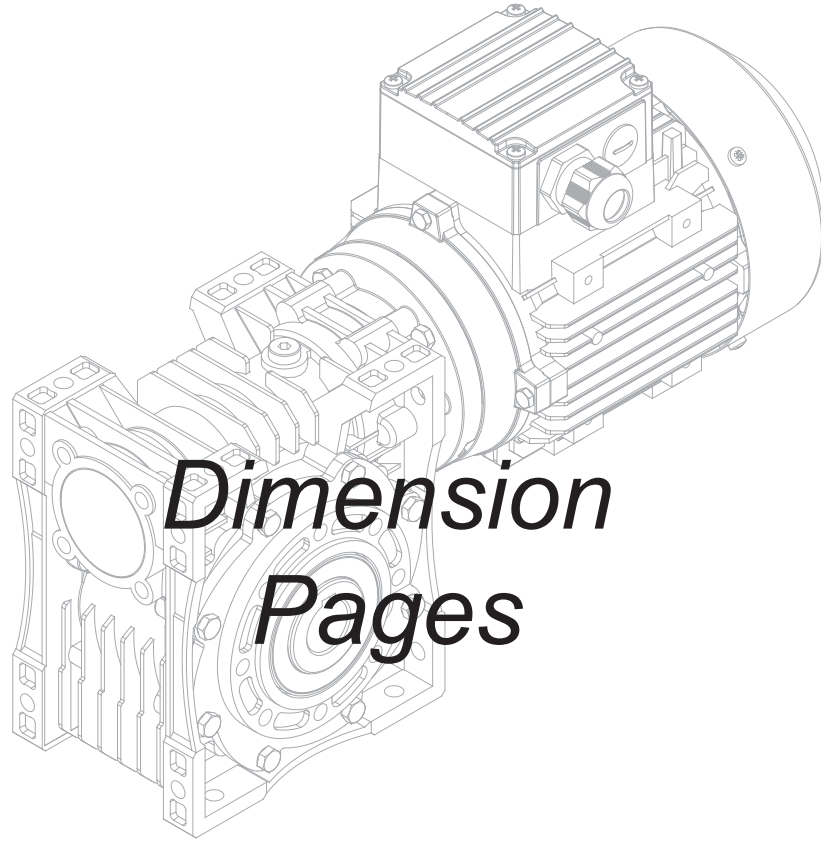

Abmessungenseiten

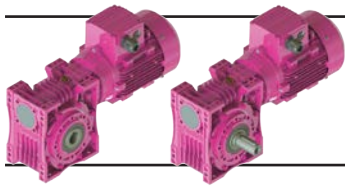

# Ölçü Sayfaları Dimension Pages Abmessungsseiten



-Mil ucu çektirme deliği DIN 332 sayfa 2 / Tapped center hole to DIN 332, sheet 2 / Zentrierung mit Gewinde DIN 332, Blatt 2

## EV030.00

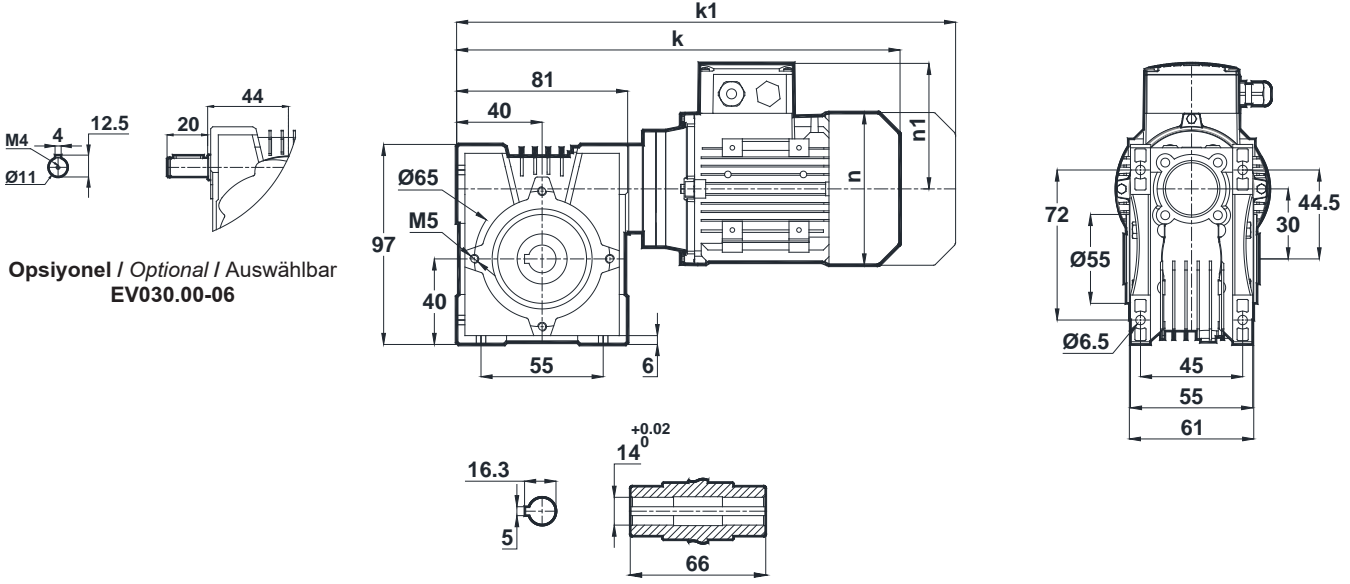

## EV030.01

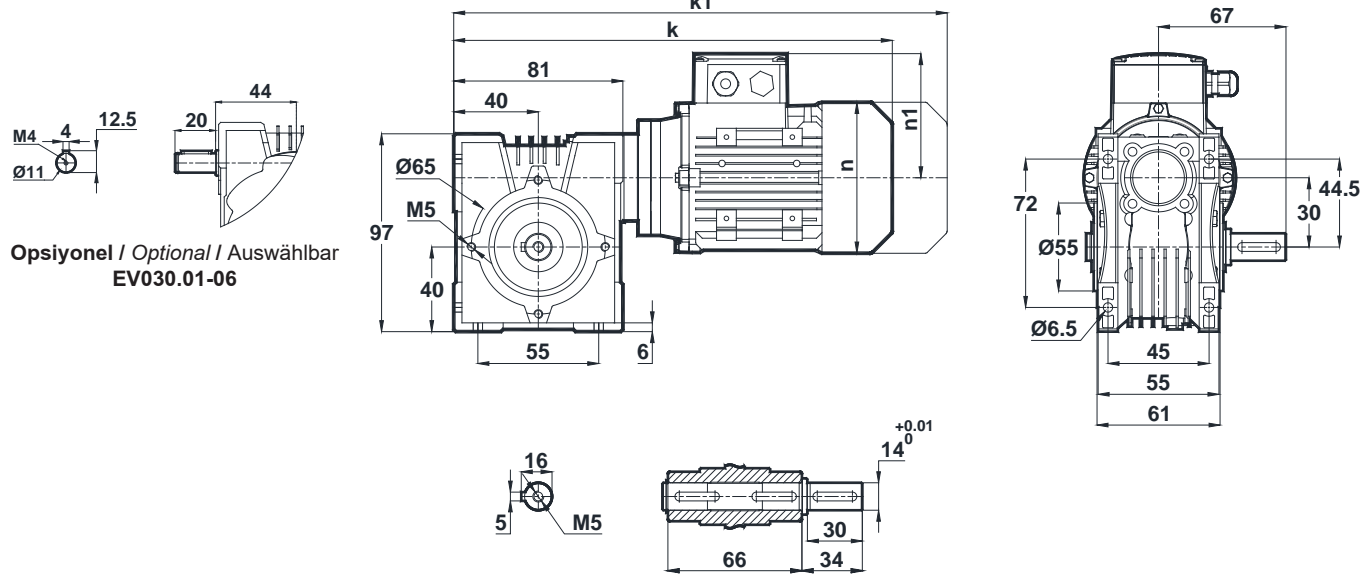

IEC B14 / B5	56	63
k	235.2	287.2
k1	-	248.2
n	105	121
n1	96	97

Klemens Pozisyonları / Terminal Box Positions / Klemmenkasten

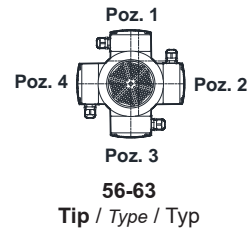

Motorlar B14 flanş ile bağlanmıştır. / Motor connections are with IEC B14 Flange / Motorbefestigung mit IEC B14 Flansch.  
"k1" Ölçüsü frenli redüktörlere aittir. 56 tip elektrik motorlu redüktörler soğutmasız, diğerleri soğutmalıdır.  
Dimensions "k1" is for motors with brake. Gearboxes with 56 type electrical motors are not fan cooled, other types are fan cooled.  
Maße "k1" ist für Bremsenmotoren. Getriebe mit 56 Motortypen sind ohne Kühlung, andere Typen sind mit Ventilator gekühlt.

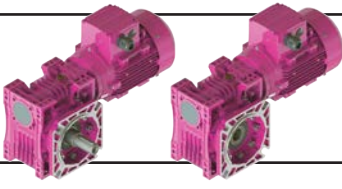

# Ölçü Sayfaları

## Dimension Pages

### Abmessungsseiten

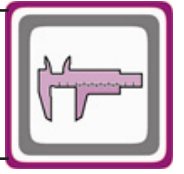

-Mil ucu çekirme deliği DIN 332 sayfa 2 / Tapped center hole to DIN 332, sheet 2 / Zentrierung mit Gewinde DIN 332, Blatt 2

#### EV030.02

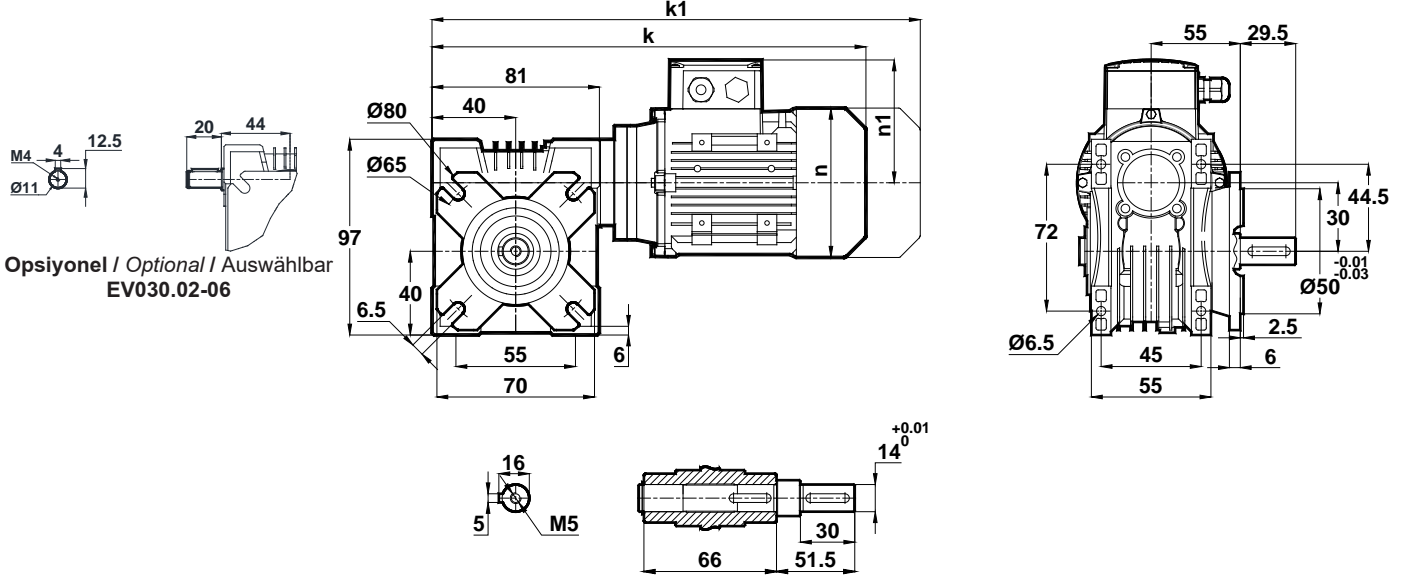

#### EV030.03

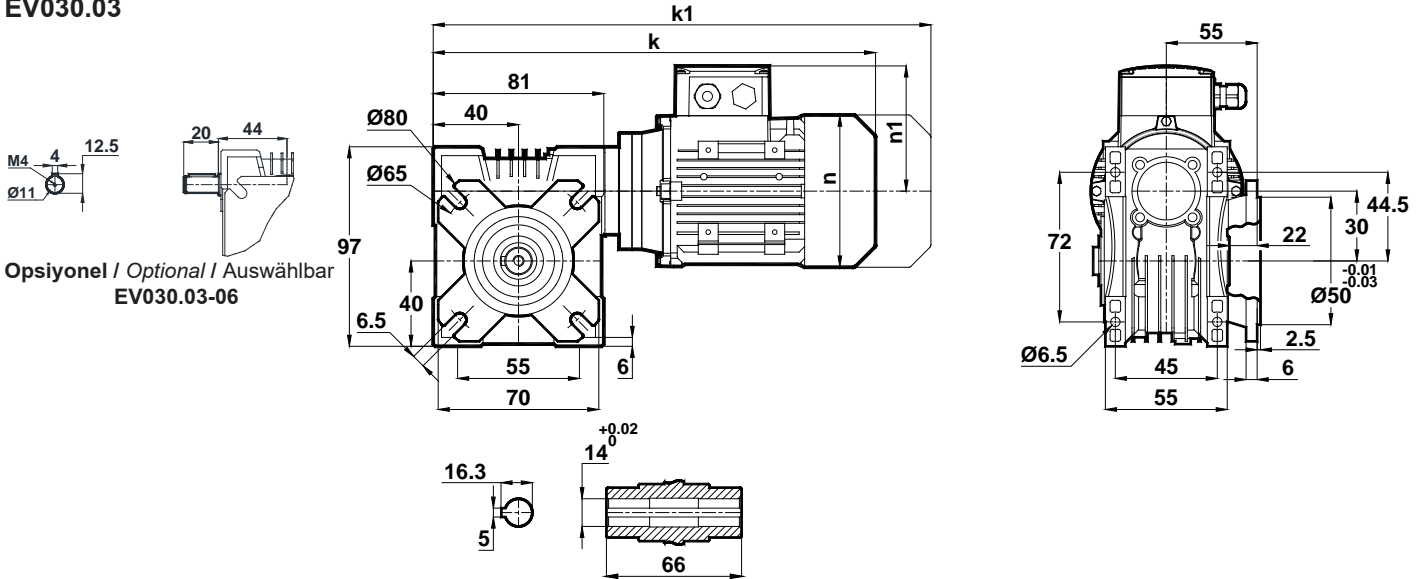

IEC B14 / B5	56	63
k	235.2	287.2
k1	-	248.2
n	105	121
n1	96	97

Klemens Pozisyonları / Terminal Box Positions / Klemmenkasten

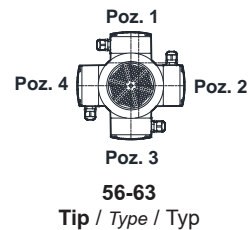

Motorlar B14 flanş ile bağlanmıştır. / Motor connections are with IEC B14 Flange / Motorbefestigung mit IEC B14 Flansch.  
"k1" Ölçüsü frenli redüktörlere aittir. 56 tip elektrik motorlu redüktörler soğutmasız, diğerleri soğutmalıdır.  
Dimensions "k1" is for motors with brake. Gearboxes with 56 type electrical motors are not fan cooled, other types are fan cooled.  
Maße "k1" sind für Bremsenmotoren. Getriebe mit 56 Motortypen sind ohne Kühlung, andere Typen sind mit Ventilator gekühlt.

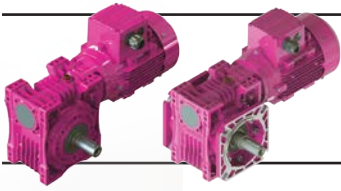

# Ölçü Sayfaları

## Dimension Pages

### Abmessungsseiten



-Mil ucu çekirme deliği DIN 332 sayfa 2 / Tapped center hole to DIN 332, sheet 2 / Zentrierung mit Gewinde DIN 332, Blatt 2

#### EV030.04

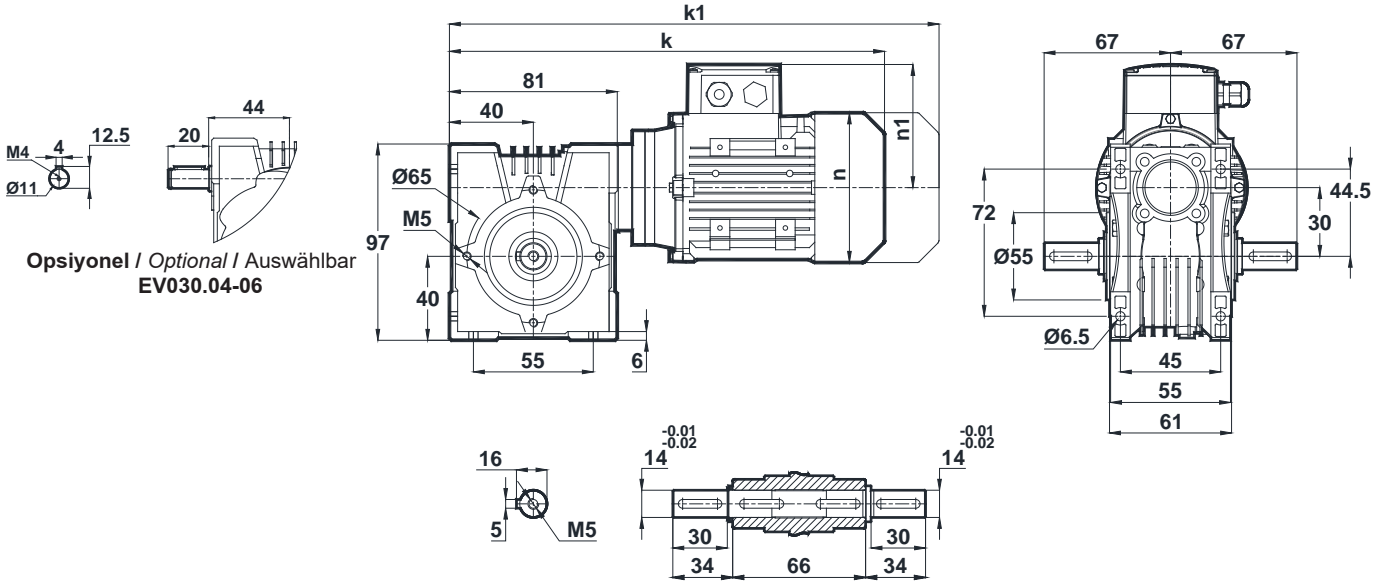

#### EV030.05

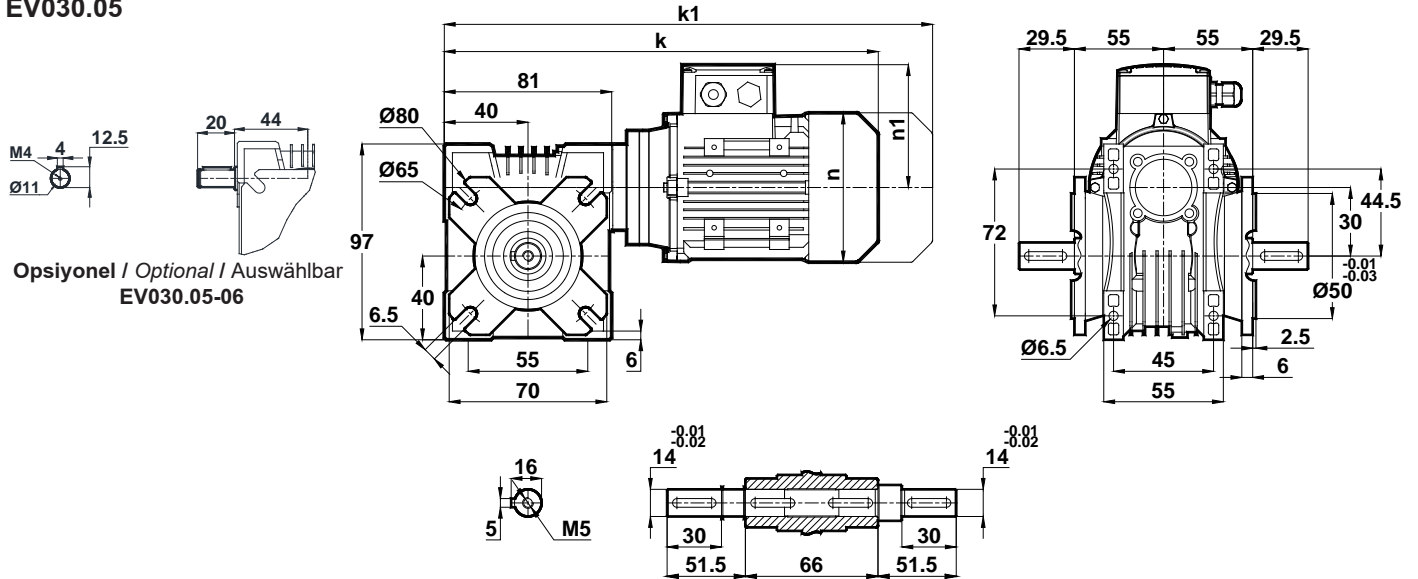

IEC B14 / B5	56	63
k	235.2	287.2
k1	-	248.2
n	105	121
n1	96	97

Klemens Pozisyonları / Terminal Box Positions / Klemmenkasten

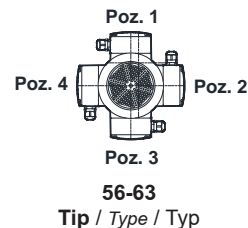

Motorlar B14 flanş ile bağlanmıştır. / Motor connections are with IEC B14 Flange / Motorbefestigung mit IEC B14 Flansch.

"k1" Ölçüsü frenli redüktörlere aittir. 56 tip elektrik motorlu redüktörler soğutmasız, diğerleri soğutmalıdır.

Dimensions "k1" is for motors with brake. Gearboxes with 56 type electrical motors are not fan cooled, other types are fan cooled.

Maße "k1" ist für Bremsenmotoren. Getriebe mit 56 Motortypen sind ohne Kühlung, andere Typen sind mit Ventilator gekühlt.

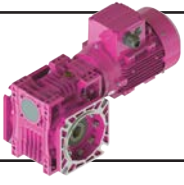

# Ölçü Sayfaları Dimension Pages Abmessungsseiten

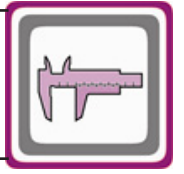

-Mil ucu çekirme deliği DIN 332 sayfa 2 / Tapped center hole to DIN 332, sheet 2 / Zentrierung mit Gewinde DIN 332, Blatt 2

EV030.08

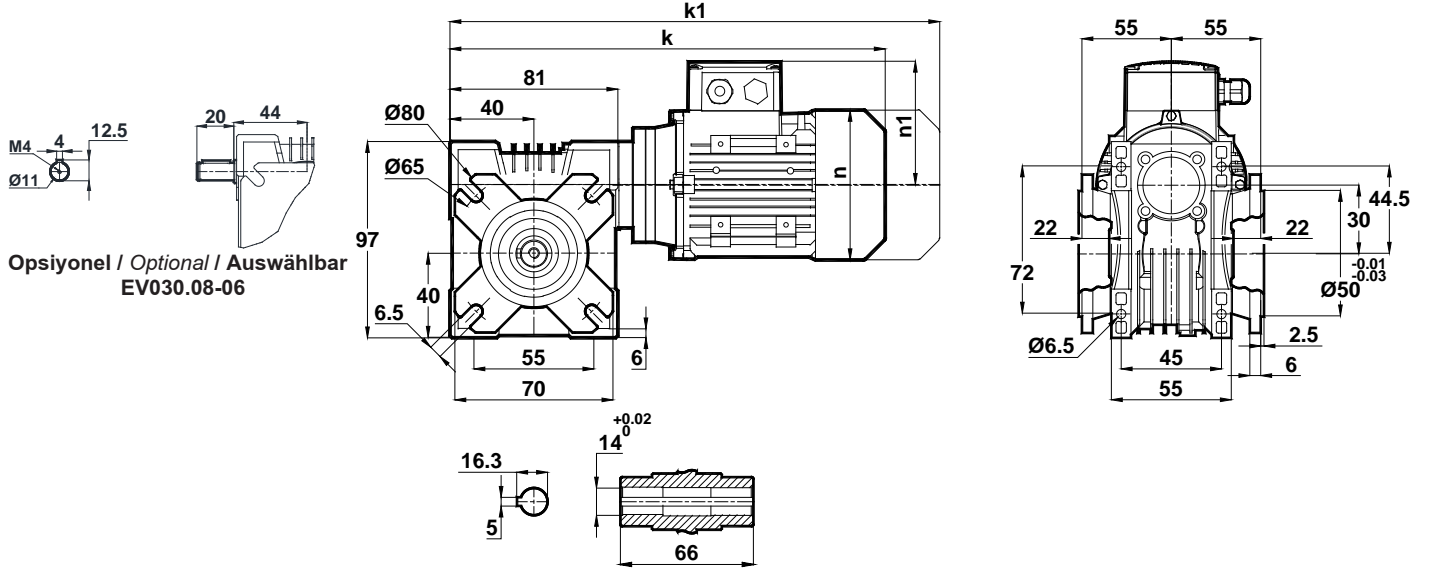

IEC B14 / B5	56	63
k	235.2	287.2
k1	-	248.2
n	105	121
n1	96	97

Klemens Pozisyonları / Terminal Box Positions / Klemmenkasten

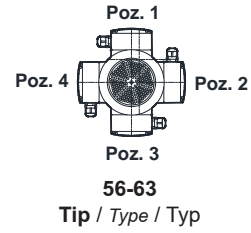

Motorlar B14 flanş ile bağlanmıştır. / Motor connections are with IEC B14 Flange / Motorbefestigung mit IEC B14 Flansch.

"k1" Ölçüsü frenli redüktörlere aittir. 56 tip elektrik motorlu redüktörler soğutmasız, diğerleri soğutmalıdır.

Dimensions "k1" is for motors with brake. Gearboxes with 56 type electrical motors are not fan cooled, other types are fan cooled.

Maße "k1" sind für Bremsmotoren. Getriebe mit 56 Motortypen sind ohne Kühlung, andere Typen sind mit Ventilator gekühlt.

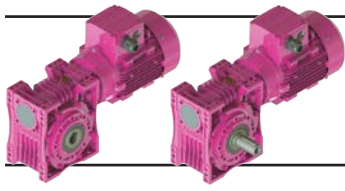

# Ölçü Sayfaları

## Dimension Pages

### Abmessungsseiten

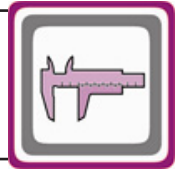

-Mil ucu çekirme deliği DIN 332 sayfa 2 / Tapped center hole to DIN 332, sheet 2 / Zentrierung mit Gewinde DIN 332, Blatt 2

#### EV040.00

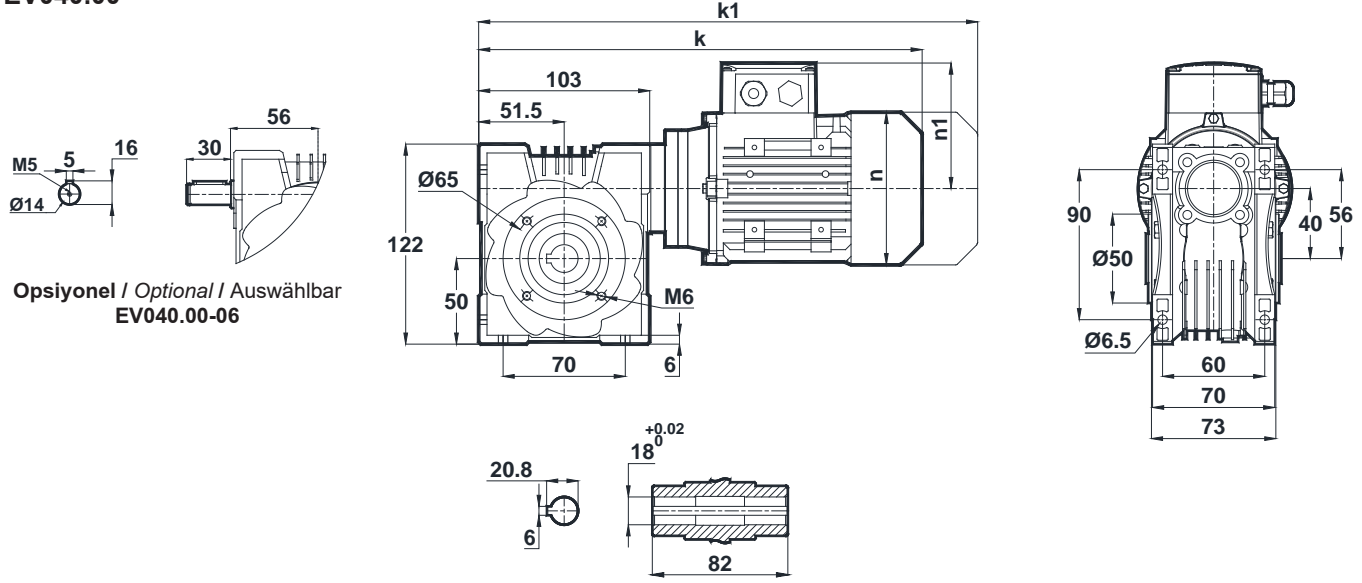

Opsiyonel / Optional / Auswählbar  
EV040.00-06

#### EV040.01

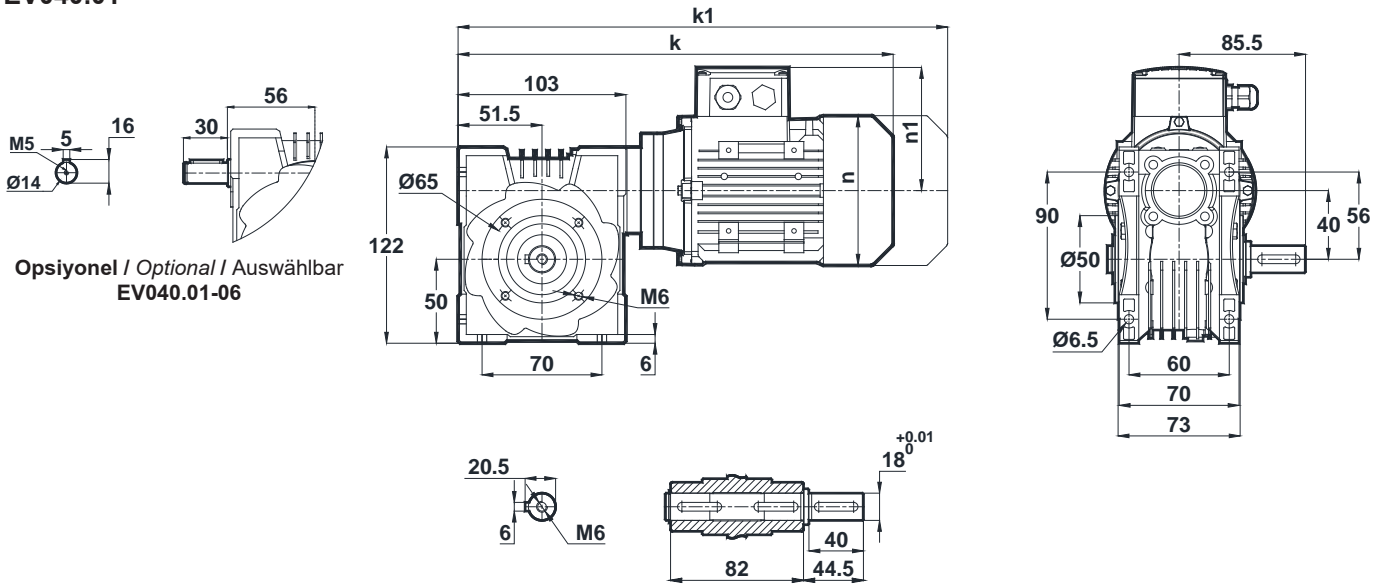

Opsiyonel / Optional / Auswählbar  
EV040.01-06

IEC B14 / B5	63	71
k	321	339
k1	382	430
n	121	137
n1	97	112

Klemens Pozisyonları / Terminal Box Positions / Klemmenkasten

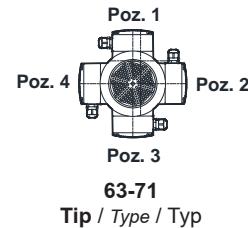

Tip / Type / Typ

Motorlar B14 flanş ile bağlanmıştır. / Motor connections are with IEC B14 Flange / Motorbefestigung mit IEC B14 Flansch.  
"k1" Ölçüsü frenli redüktörlere aittir. 56 tip elektrik motorlu redüktörler soğutmasız, diğerleri soğutmalıdır.  
Dimensions "k1" is for motors with brake. Gearboxes with 56 type electrical motors are not fan cooled, other types are fan cooled.  
Maße "k1" ist für Bremsenmotoren. Getriebe mit 56 Motortypen sind ohne Kühlung, andere Typen sind mit Ventilator gekühlt.



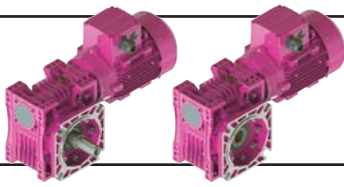

# Ölçü Sayfaları

## Dimension Pages

## Abmessungsseiten

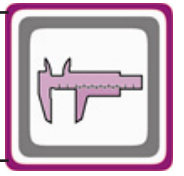

-Mil ucu çekirme deliği DIN 332 sayfa 2 / Tapped center hole to DIN 332, sheet 2 / Zentrierung mit Gewinde DIN 332, Blatt 2

### EV040.02

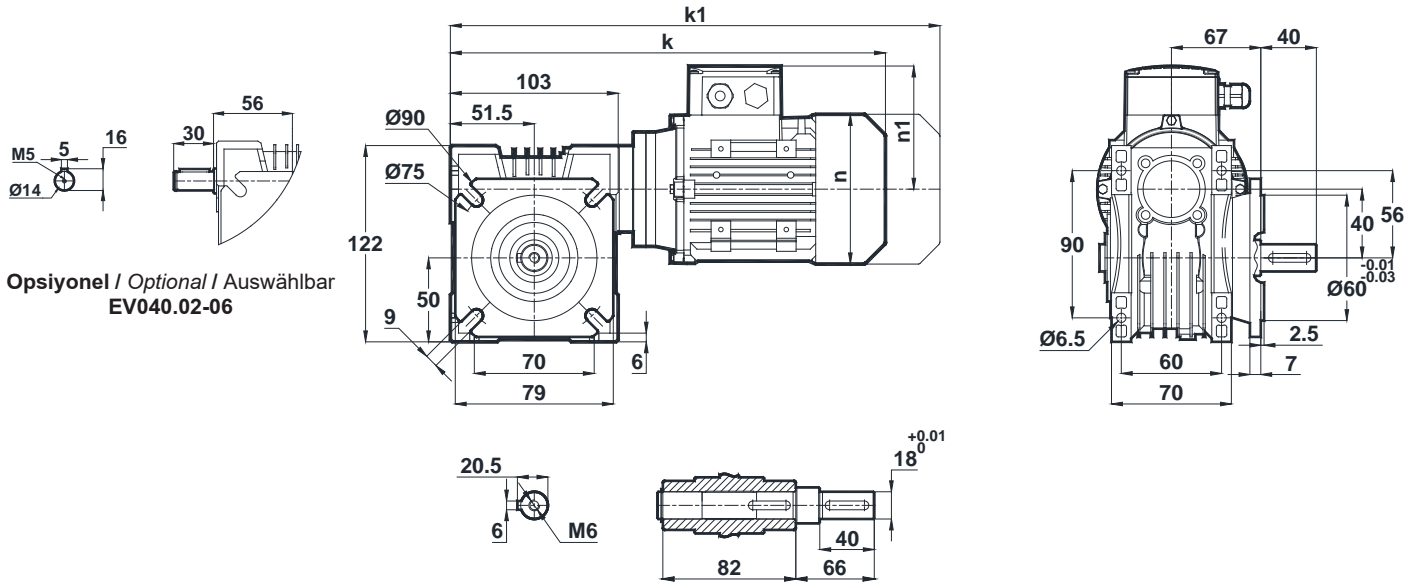

Opsiyonel / Optional / Auswählbar  
EV040.02-06

### EV040.03

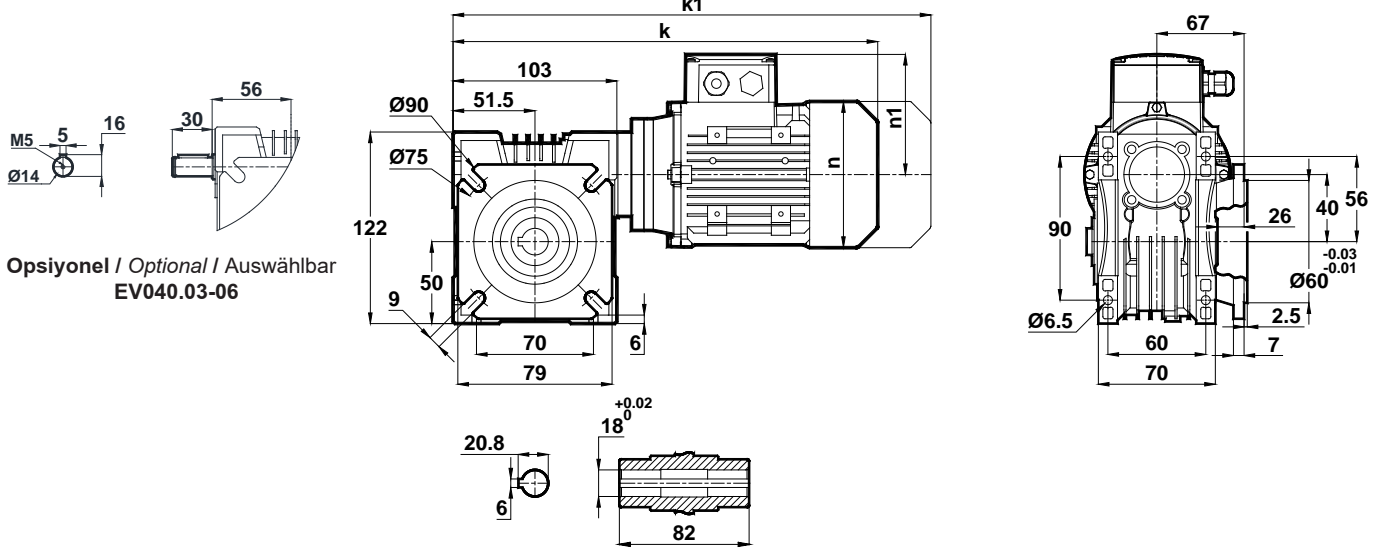

Opsiyonel / Optional / Auswählbar  
EV040.03-06

Klemens Pozisyonları / Terminal Box Positions / Klemmenkasten

IEC B14 / B5	63	71
k	321	339
k1	382	430
n	121	137
n1	97	112

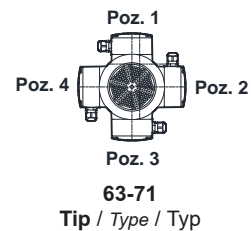

Motorlar B14 flanş ile bağlanmıştır. / Motor connections are with IEC B14 Flange / Motorbefestigung mit IEC B14 Flansch.  
"k1" Ölçüsü frenli redüktörlere aittir. 56 tip elektrik motorlu redüktörler soğutmasız, diğerleri soğutmalıdır.  
Dimensions "k1" is for motors with brake. Gearboxes with 56 type electrical motors are not fan cooled, other types are fan cooled.  
Maße "k1" sind für Bremsenmotoren. Getriebe mit 56 Motortypen sind ohne Kühlung, andere Typen sind mit Ventilator gekühlt.

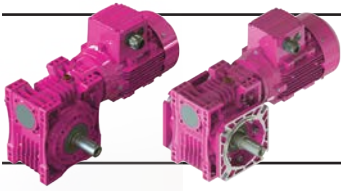

# Ölçü Sayfaları

## Dimension Pages

### Abmessungsseiten



-Mil ucu çekirme deliği DIN 332 sayfa 2 / Tapped center hole to DIN 332, sheet 2 / Zentrierung mit Gewinde DIN 332, Blatt 2

#### EV040.04

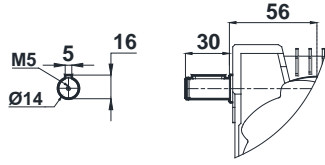

Opsiyonel / Optional / Auswählbar  
EV040.04-06

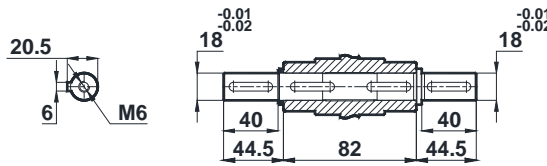
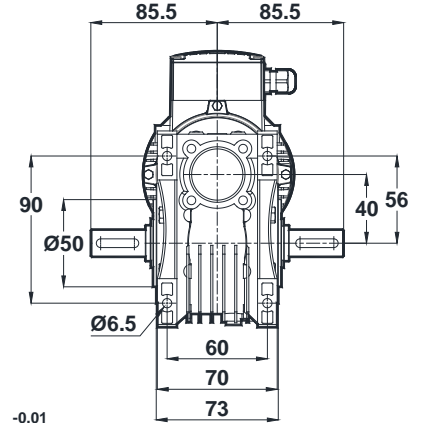
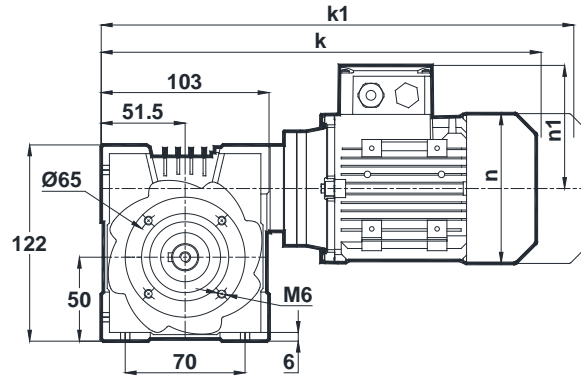

#### EV040.05

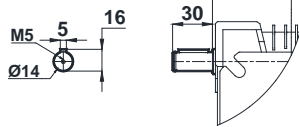

Opsiyonel / Optional / Auswählbar  
EV040.05-06

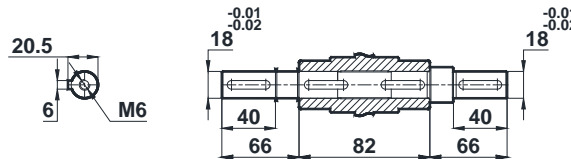
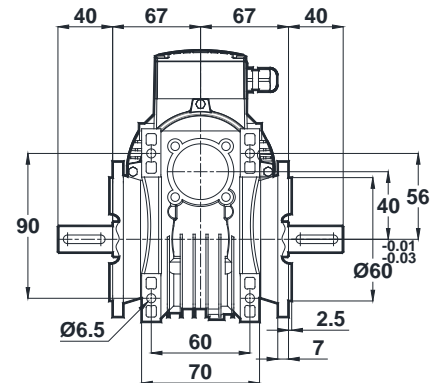
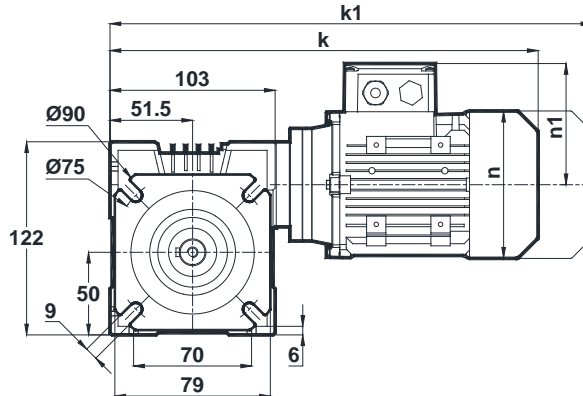

IEC B14 / B5	63	71
k	321	339
k1	382	430
n	121	137
n1	97	112

Klemens Pozisyonları / Terminal Box Positions / Klemmenkasten

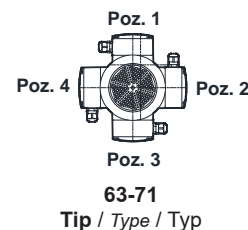

Tip / Type / Typ

Motorlar B14 flanş ile bağlanmıştır. / Motor connections are with IEC B14 Flange / Motorbefestigung mit IEC B14 Flansch.

"k1" Ölçüsü frenli redüktörlere aittir. 56 tip elektrik motorlu redüktörler soğutmasız, diğerleri soğutmalıdır.

Dimensions "k1" is for motors with brake. Gearboxes with 56 type electrical motors are not fan cooled, other types are fan cooled.

Maße "k1" ist für Bremsenmotoren. Getriebe mit 56 Motortypen sind ohne Kühlung, andere Typen sind mit Ventilator gekühlt.

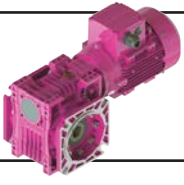

# Ölçü Sayfaları Dimension Pages Abmessungsseiten

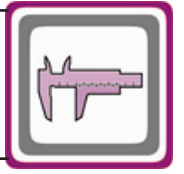

-Mil ucu çekirme deliği DIN 332 sayfa 2 / Tapped center hole to DIN 332, sheet 2 / Zentrierung mit Gewinde DIN 332, Blatt 2

EV040.08

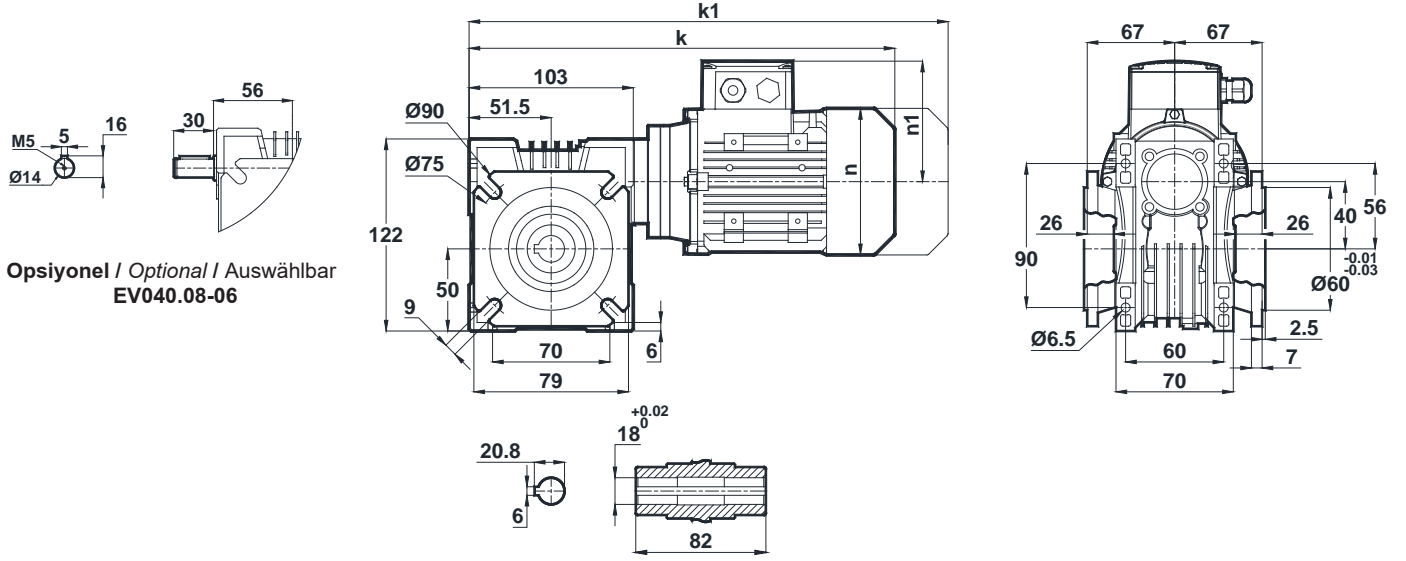

IEC B14 / B5	63	71
k	321	339
k1	382	430
n	121	137
n1	97	112

Klemens Pozisyonları / Terminal Box Positions / Klemmenkasten

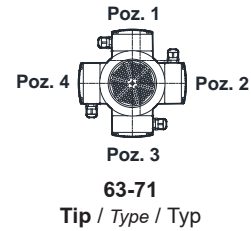

Motorlar B14 flanş ile bağlanmıştır. / Motor connections are with IEC B14 Flange / Motorbefestigung mit IEC B14 Flansch.

"k1" Ölçüsü frenli redüktörlere aittir. 56 tip elektrik motorlu redüktörler soğutmasız, diğerleri soğutmalıdır.

Dimensions "k1" is for motors with brake. Gearboxes with 56 type electrical motors are not fan cooled, other types are fan cooled.

Maße "k1" sind für Bremsenmotoren. Getriebe mit 56 Motortypen sind ohne Kühlung, andere Typen sind mit Ventilator gekühlt.

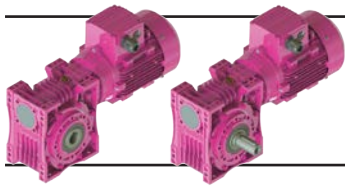

# Ölçü Sayfaları

## Dimension Pages

### Abmessungsseiten



-Mil ucu çekirme deliği DIN 332 sayfa 2 / Tapped center hole to DIN 332, sheet 2 / Zentrierung mit Gewinde DIN 332, Blatt 2

#### EV050.00

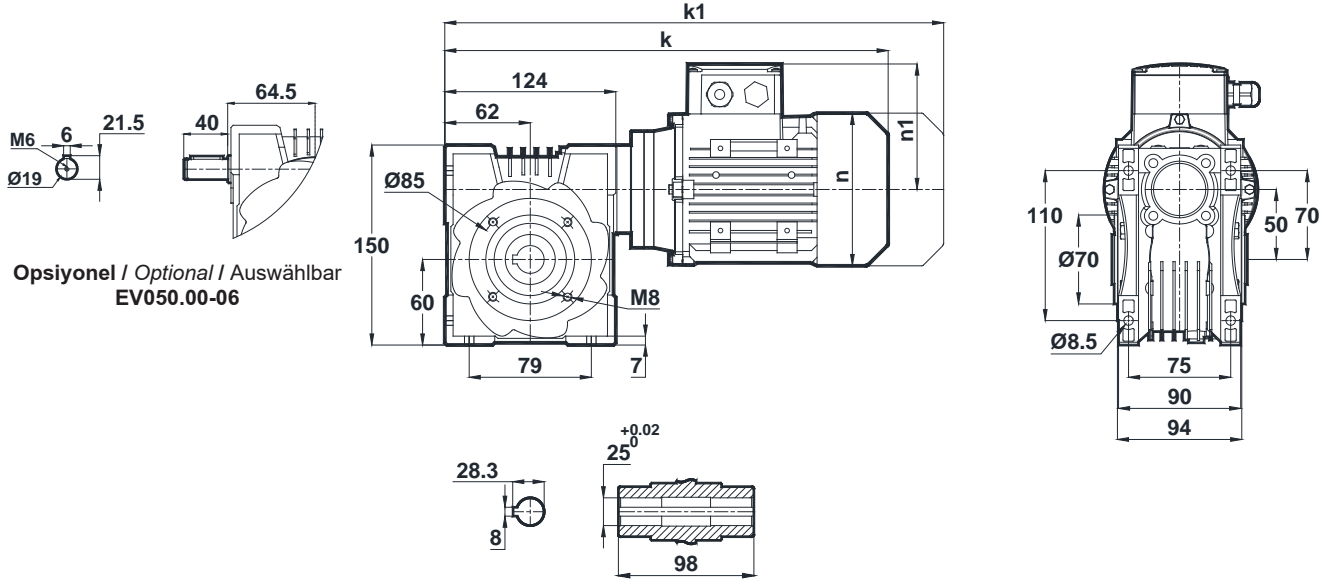

#### EV050.01

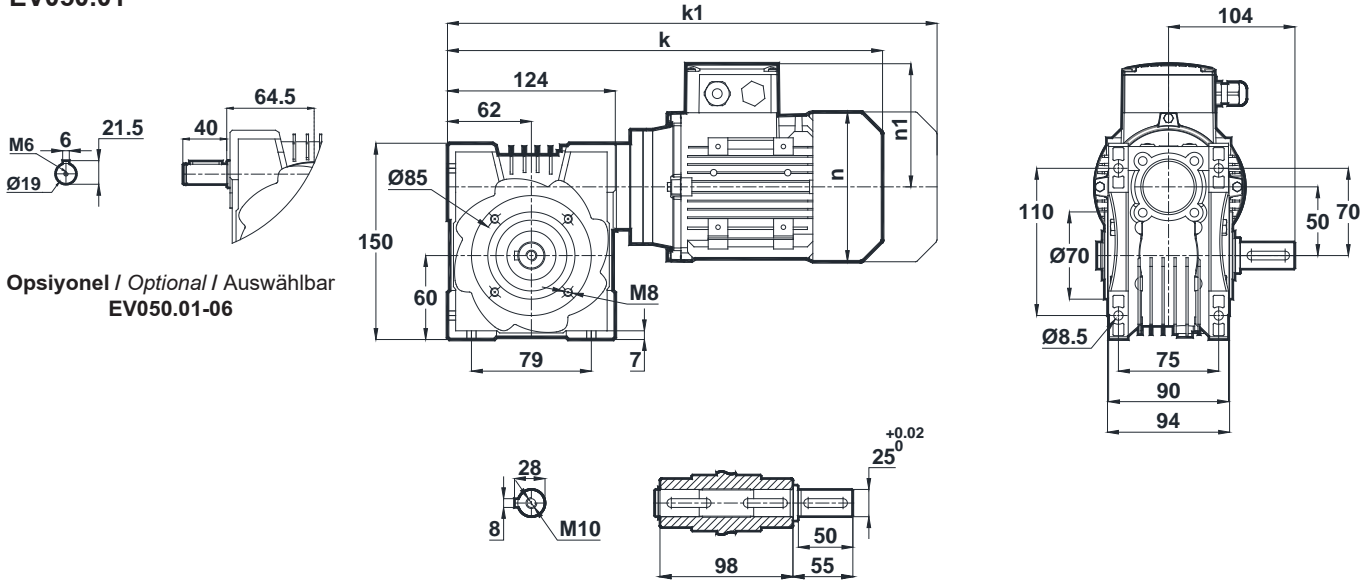

IEC B14 / B5	63	71	80	90S	90L
k	341.7	359.7	382.7	423.7	423.7
k1	402.7	450.7	475.7	527.2	527.2
n	121	137	155	176	176
n1	97	112	121	133	133

Klemens Pozisyonları / Terminal Box Positions / Klemmenkasten

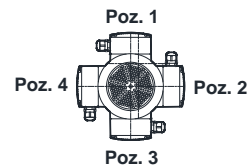

63-71-80-90  
Tip / Type / Typ

Motorlar B14 flanş ile bağlanmıştır. / Motor connections are with IEC B14 Flange / Motorbefestigung mit IEC B14 Flansch.  
"k1" Ölçüsü frenli redüktörlere aittir. 56 tip elektrik motorlu redüktörler soğutmasız, diğerleri soğutmalıdır.  
Dimensions "k1" is for motors with brake. Gearboxes with 56 type electrical motors are not fan cooled, other types are fan cooled.  
Maße "k1" ist für Bremsenmotoren. Getriebe mit 56 Motortypen sind ohne Kühlung, andere Typen sind mit Ventilator gekühlt.

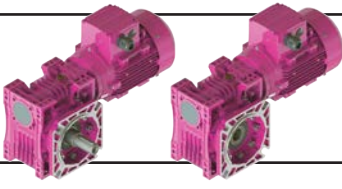

# Ölçü Sayfaları

## Dimension Pages

### Abmessungsseiten



-Mil ucu çekirme deliği DIN 332 sayfa 2 / Tapped center hole to DIN 332, sheet 2 / Zentrierung mit Gewinde DIN 332, Blatt 2

#### EV050.02

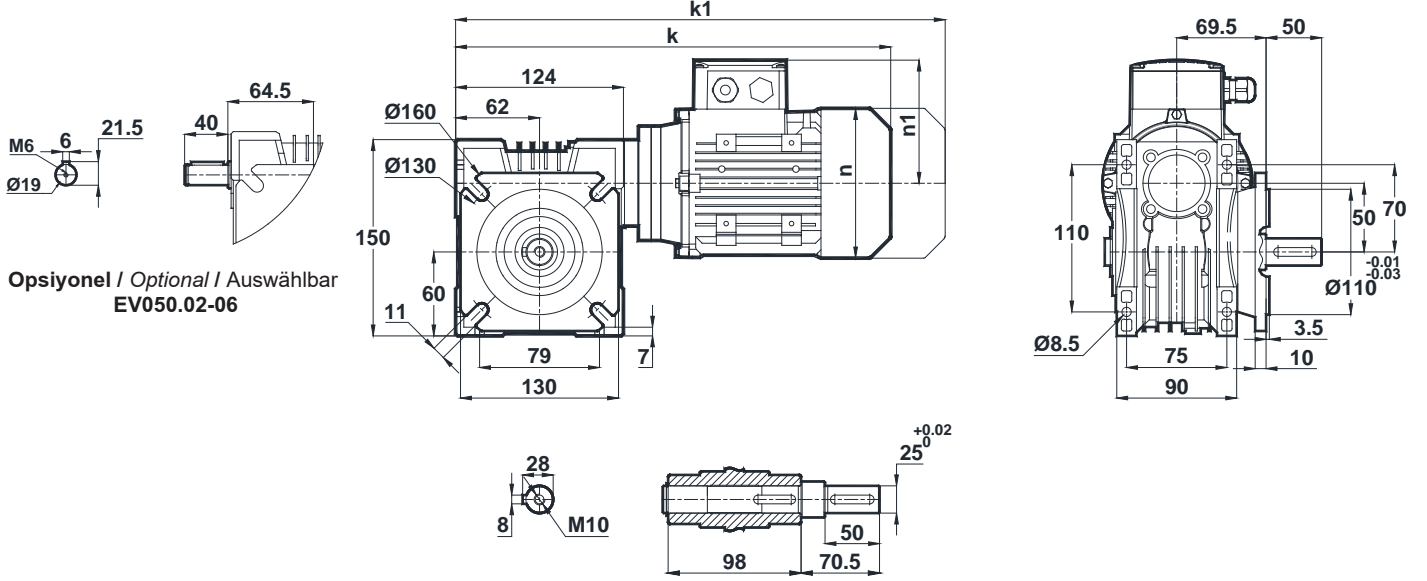

#### EV050.03

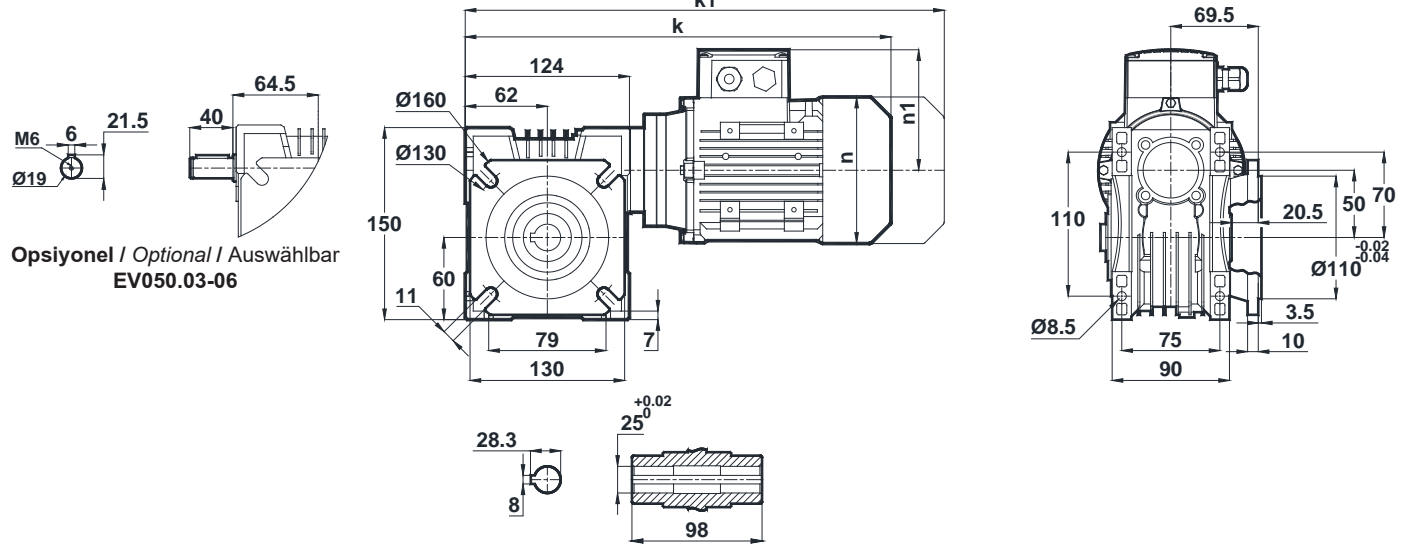

IEC B14 / B5	63	71	80	90S	90L
k	341.7	359.7	382.7	423.7	423.7
k1	402.7	450.7	475.7	527.2	527.2
n	121	137	155	176	176
n1	97	112	121	133	133

#### Klemens Pozisyonları / Terminal Box Positions / Klemmenkasten

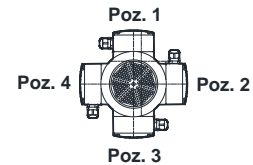

63-71-80-90  
Tip / Type / Typ

Motorlar B14 flanş ile bağlanmıştır. / Motor connections are with IEC B14 Flange / Motorbefestigung mit IEC B14 Flansch.

"k1" Ölçüsü frenli redüktörlere aittir. 56 tip elektrik motorlu redüktörler soğutmasız, diğerleri soğutmalıdır.

Dimensions "k1" is for motors with brake. Gearboxes with 56 type electrical motors are not fan cooled, other types are fan cooled.

Maße "k1" sind für Bremsenmotoren. Getriebe mit 56 Motortypen sind ohne Kühlung, andere Typen sind mit Ventilator gekühlt.

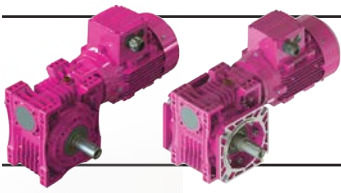

# Ölçü Sayfaları

## Dimension Pages

### Abmessungsseiten

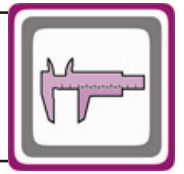

-Mil ucu çekirme deliği DIN 332 sayfa 2 / Tapped center hole to DIN 332, sheet 2 / Zentrierung mit Gewinde DIN 332, Blatt 2

#### EV050.04

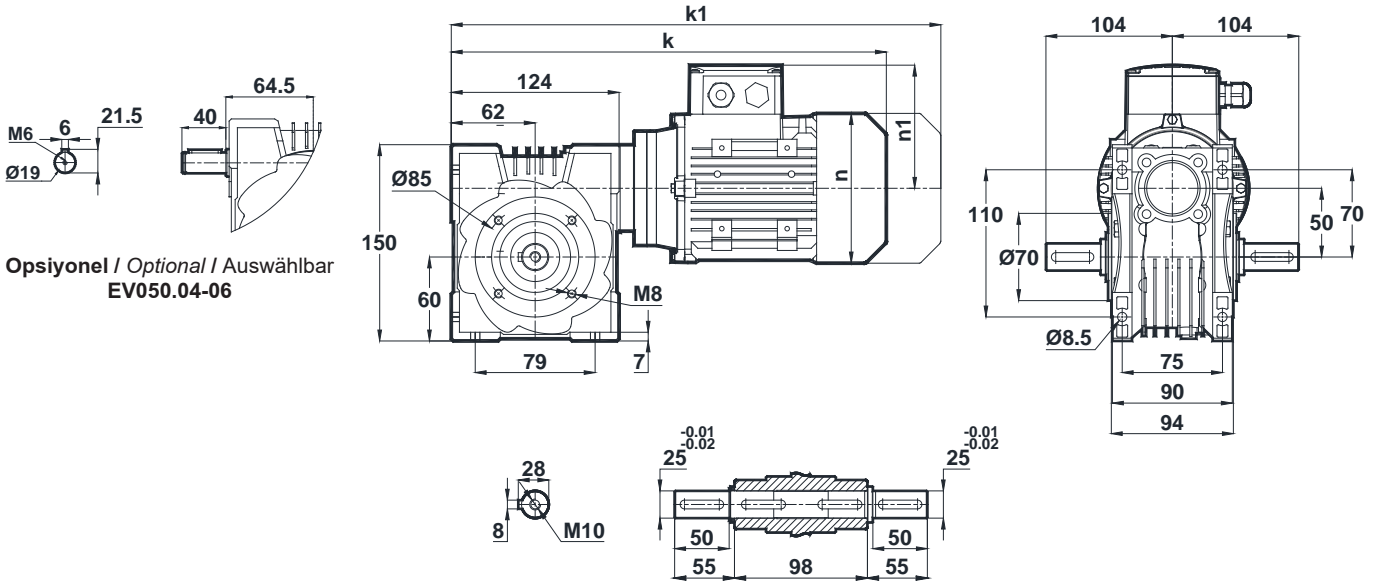

#### EV050.05

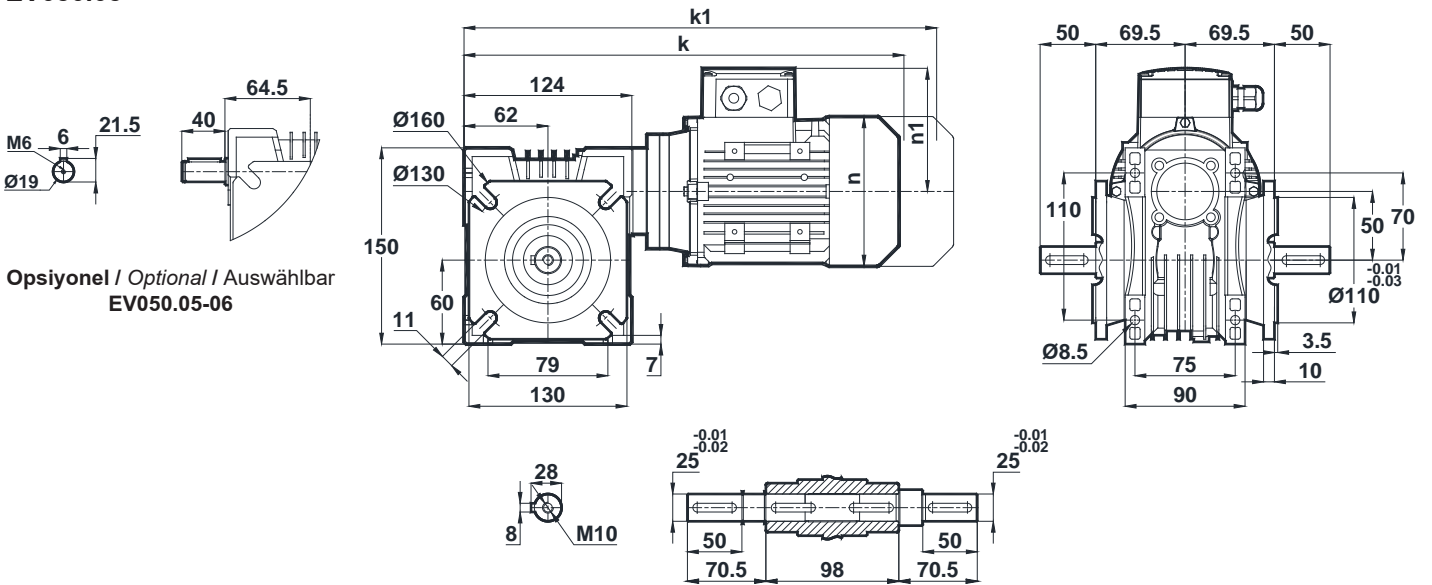

IEC B14 / B5	63	71	80	90S	90L
k	341.7	359.7	382.7	423.7	423.7
k1	402.7	450.7	475.7	527.2	527.2
n	121	137	155	176	176
n1	97	112	121	133	133

Klemens Pozisyonları / Terminal Box Positions / Klemmenkasten

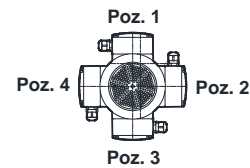

63-71-80-90  
Tip / Type / Typ

Motorlar B14 flanş ile bağlanmıştır. / Motor connections are with IEC B14 Flange / Motorbefestigung mit IEC B14 Flansch.

"k1" Ölçüsü frenli redüktörlere aittir. 56 tip elektrik motorlu redüktörler soğutmasız, diğerleri soğutmalıdır.

Dimensions "k1" is for motors with brake. Gearboxes with 56 type electrical motors are not fan cooled, other types are fan cooled.

Maße "k1" ist für Bremsenmotoren. Getriebe mit 56 Motortypen sind ohne Kühlung, andere Typen sind mit Ventilator gekühlt.

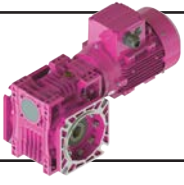

# Ölçü Sayfaları Dimension Pages Abmessungsseiten

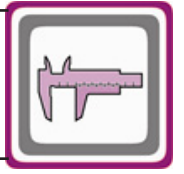

-Mil ucu çekirme deliği DIN 332 sayfa 2 / Tapped center hole to DIN 332, sheet 2 / Zentrierung mit Gewinde DIN 332, Blatt 2

EV050.08

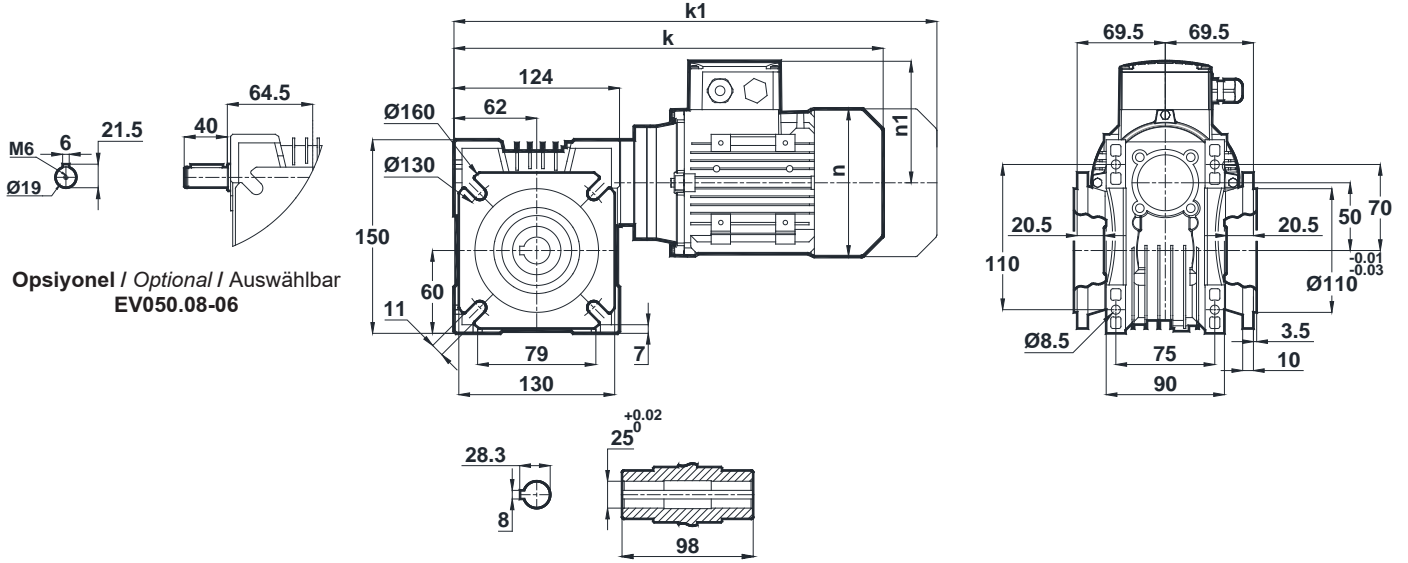

Opsiyonel / Optional / Auswählbar  
EV050.08-06

IEC B14 / B5	63	71	80	90S	90L
k	341.7	359.7	382.7	423.7	423.7
k1	402.7	450.7	475.7	527.2	527.2
n	121	137	155	176	176
n1	97	112	121	133	133

Klemens Pozisyonları / Terminal Box Positions / Klemmenkasten

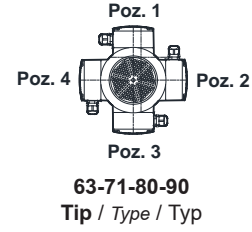

Motorlar B14 flanş ile bağlanmıştır. / Motor connections are with IEC B14 Flange / Motorbefestigung mit IEC B14 Flansch.

"k1" Ölçüsü frenli redüktörlere aittir. 56 tip elektrik motorlu redüktörler soğutmasız, diğerleri soğutmalıdır.

Dimensions "k1" is for motors with brake. Gearboxes with 56 type electrical motors are not fan cooled, other types are fan cooled.

Maße "k1" sind für Bremsenmotoren. Getriebe mit 56 Motortypen sind ohne Kühlung, andere Typen sind mit Ventilator gekühlt.

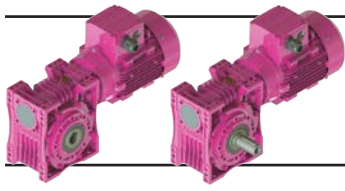

# Ölçü Sayfaları

## Dimension Pages

### Abmessungsseiten

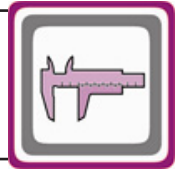

-Mil ucu çekirme deliği DIN 332 sayfa 2 / Tapped center hole to DIN 332, sheet 2 / Zentrierung mit Gewinde DIN 332, Blatt 2

#### EV063.00

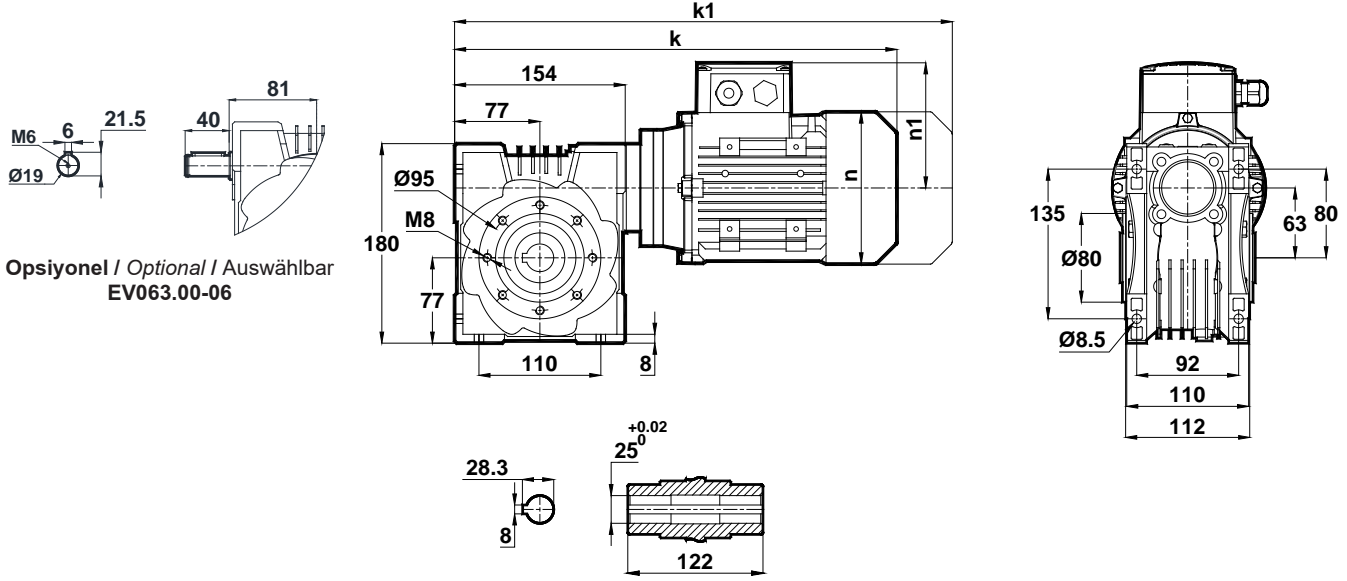

Opsiyonel / Optional / Auswählbar  
EV063.00-06

#### EV063.01

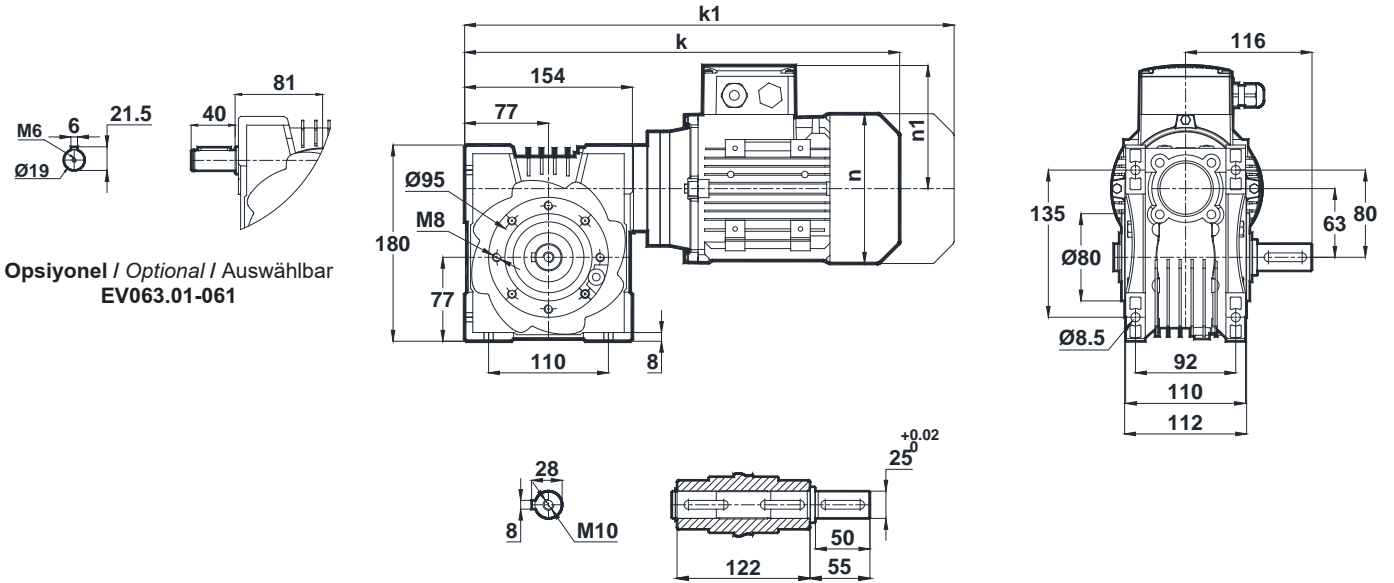

Opsiyonel / Optional / Auswählbar  
EV063.01-061

IEC B14 / B5	71	80	90S	90L
k	389.7	412.7	453.7	453.7
k1	480.7	505.7	557.2	557.2
n	137	155	176	176
n1	112	121	133	133

Klemens Pozisyonları / Terminal Box Positions / Klemmenkasten

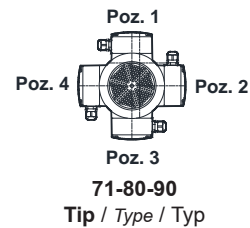

Motorlar B14 flanş ile bağlanmıştır. / Motor connections are with IEC B14 Flange / Motorbefestigung mit IEC B14 Flansch.  
"k1" Ölçüsü frenli redüktörlere aittir. 56 tip elektrik motorlu redüktörler soğutmasız, diğerleri soğutmalıdır.  
Dimensions "k1" is for motors with brake. Gearboxes with 56 type electrical motors are not fan cooled, other types are fan cooled.  
Maße "k1" ist für Bremsenmotoren. Getriebe mit 56 Motortypen sind ohne Kühlung, andere Typen sind mit Ventilator gekühlt.



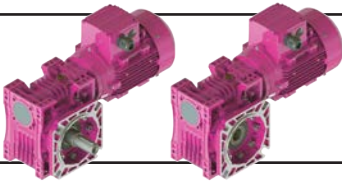

# Ölçü Sayfaları

## Dimension Pages

### Abmessungsseiten



-Mil ucu çekirme deliği DIN 332 sayfa 2 / Tapped center hole to DIN 332, sheet 2 / Zentrierung mit Gewinde DIN 332, Blatt 2

#### EV063.02

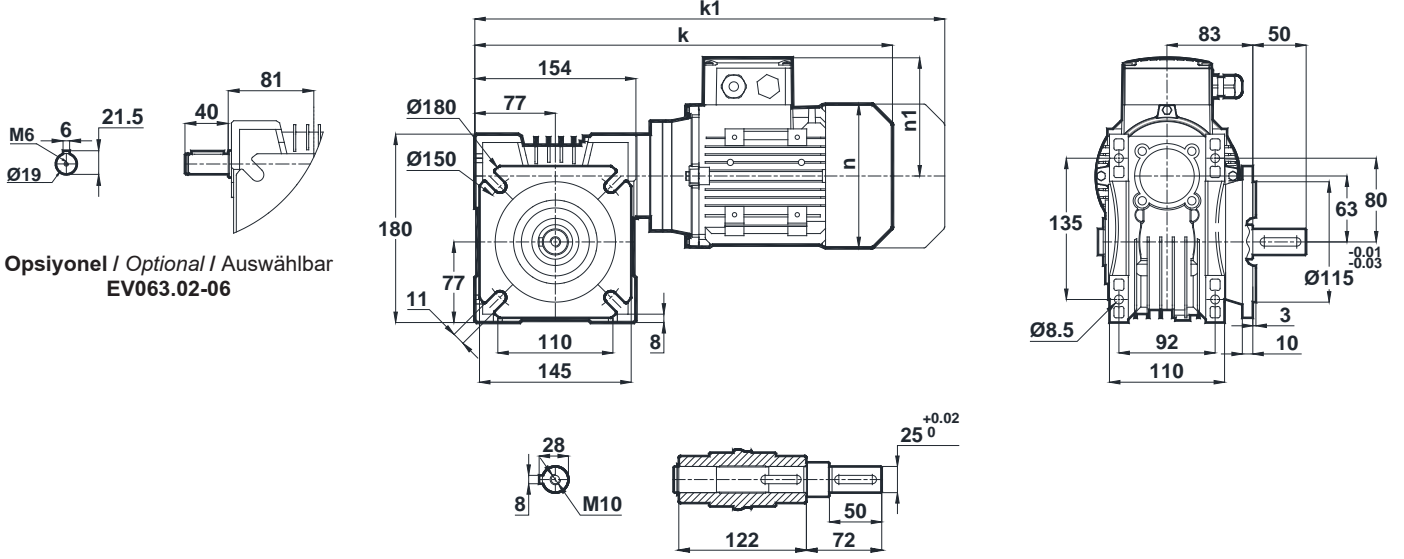

#### EV063.03

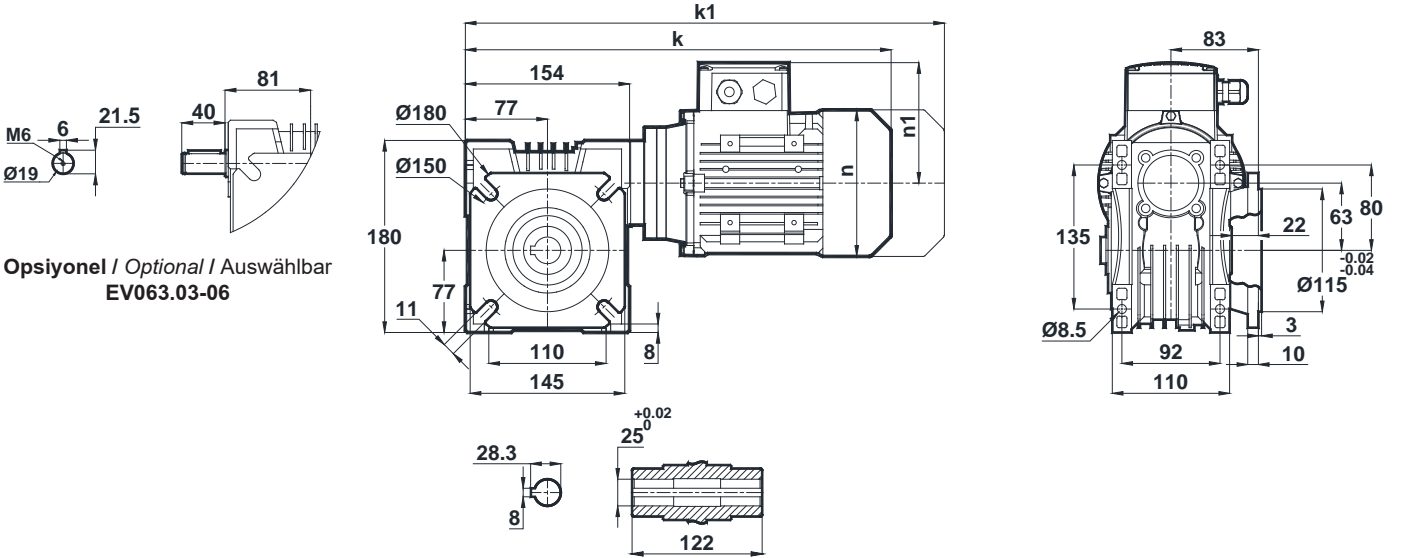

IEC B14 / B5	71	80	90S	90L
k	389.7	412.7	453.7	453.7
k1	480.7	505.7	557.2	557.2
n	137	155	176	176
n1	112	121	133	133

Klemens Pozisyonları / Terminal Box Positions / Klemmenkasten

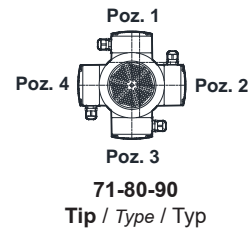

Motorlar B14 flanş ile bağlanmıştır. / Motor connections are with IEC B14 Flange / Motorbefestigung mit IEC B14 Flansch.

"k1" Ölçüsü frenli redüktörlere aittir. 56 tip elektrik motorlu redüktörler soğutmasız, diğerleri soğutmalıdır.

Dimensions "k1" is for motors with brake. Gearboxes with 56 type electrical motors are not fan cooled, other types are fan cooled.

Maße "k1" sind für Bremsenmotoren. Getriebe mit 56 Motortypen sind ohne Kühlung, andere Typen sind mit Ventilator gekühlt.

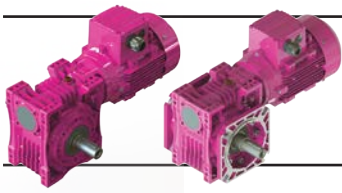

# Ölçü Sayfaları

## Dimension Pages

### Abmessungsseiten

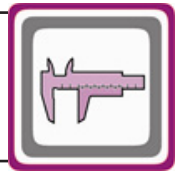

-Mil ucu çekirme deliği DIN 332 sayfa 2 / Tapped center hole to DIN 332, sheet 2 / Zentrierung mit Gewinde DIN 332, Blatt 2

#### EV063.04

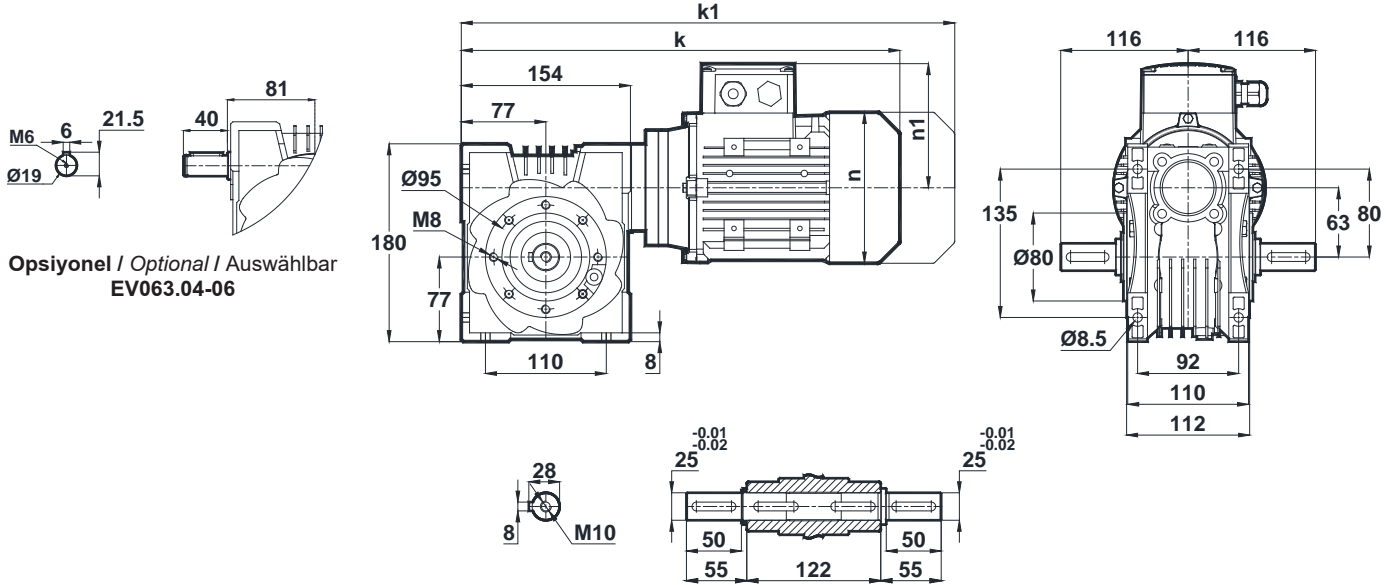

Opsiyonel / Optional / Auswählbar  
EV063.04-06

#### EV063.05

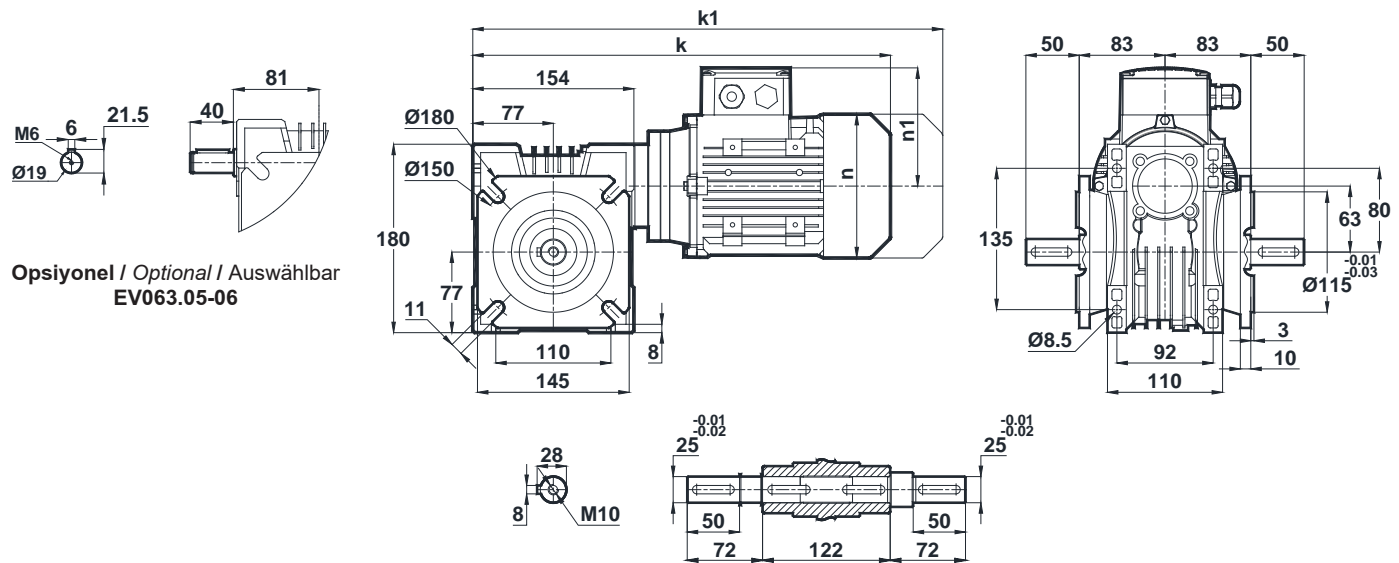

Opsiyonel / Optional / Auswählbar  
EV063.05-06

IEC B14 / B5	71	80	90S	90L
k	389.7	412.7	453.7	453.7
k1	480.7	505.7	557.2	557.2
n	137	155	176	176
n1	112	121	133	133

Klemens Pozisyonları / Terminal Box Positions / Klemmenkasten

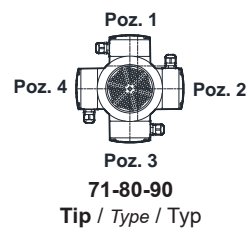

Motorlar B14 flanş ile bağlanmıştır. / Motor connections are with IEC B14 Flange / Motorbefestigung mit IEC B14 Flansch.

"k1" Ölçüsü frenli redüktörlere aittir. 56 tip elektrik motorlu redüktörler soğutmasız, diğerleri soğutmalıdır.

Dimensions "k1" is for motors with brake. Gearboxes with 56 type electrical motors are not fan cooled, other types are fan cooled.

Maße "k1" ist für Bremsenmotoren. Getriebe mit 56 Motortypen sind ohne Kühlung, andere Typen sind mit Ventilator gekühlt.

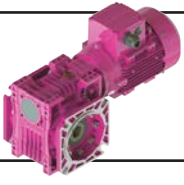

# Ölçü Sayfaları Dimension Pages Abmessungsseiten



-Mil ucu çekirme deliği DIN 332 sayfa 2 / Tapped center hole to DIN 332, sheet 2 / Zentrierung mit Gewinde DIN 332, Blatt 2  
EV063.08

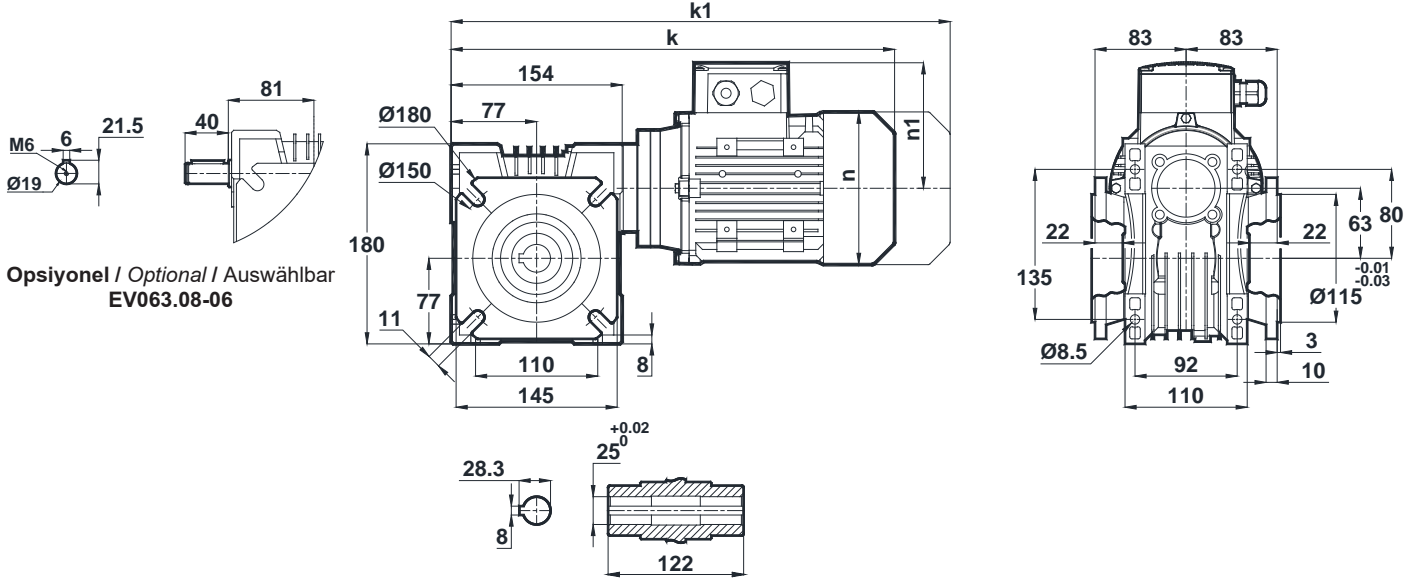

IEC B14 / B5	71	80	90S	90L
k	389.7	412.7	453.7	453.7
k1	480.7	505.7	557.2	557.2
n	137	155	176	176
n1	112	121	133	133

Klemens Pozisyonları / Terminal Box Positions / Klemmenkasten

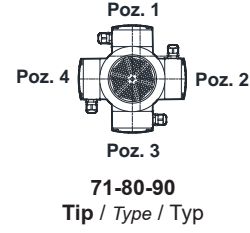

71-80-90

Tip / Type / Typ

Motorlar B14 flanş ile bağlanmıştır. / Motor connections are with IEC B14 Flange / Motorbefestigung mit IEC B14 Flansch.  
"k1" Ölçüsü frenli redüktörlere aittir. 56 tip elektrik motorlu redüktörler soğutmasız, diğerleri soğutmalıdır.  
Dimensions "k1" is for motors with brake. Gearboxes with 56 type electrical motors are not fan cooled, other types are fan cooled.  
Maße "k1" sind für Bremsenmotoren. Getriebe mit 56 Motortypen sind ohne Kühlung, andere Typen sind mit Ventilator gekühlt.

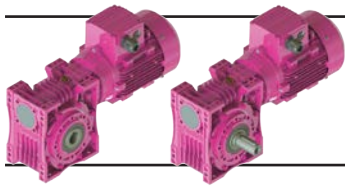

# Ölçü Sayfaları

## Dimension Pages

### Abmessungsseiten

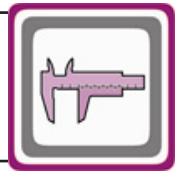

-Mil ucu çekirme deliği DIN 332 sayfa 2 / Tapped center hole to DIN 332, sheet 2 / Zentrierung mit Gewinde DIN 332, Blatt 2

#### EV075.00

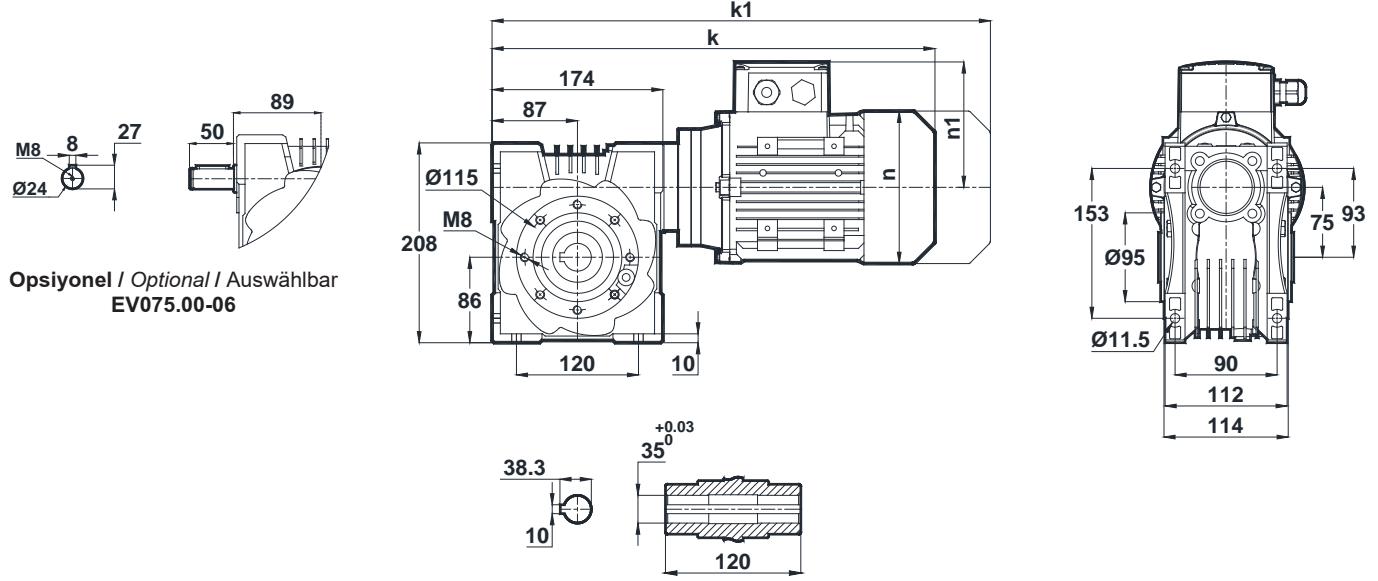

Opsiyonel / Optional / Auswählbar  
EV075.00-06

#### EV075.01

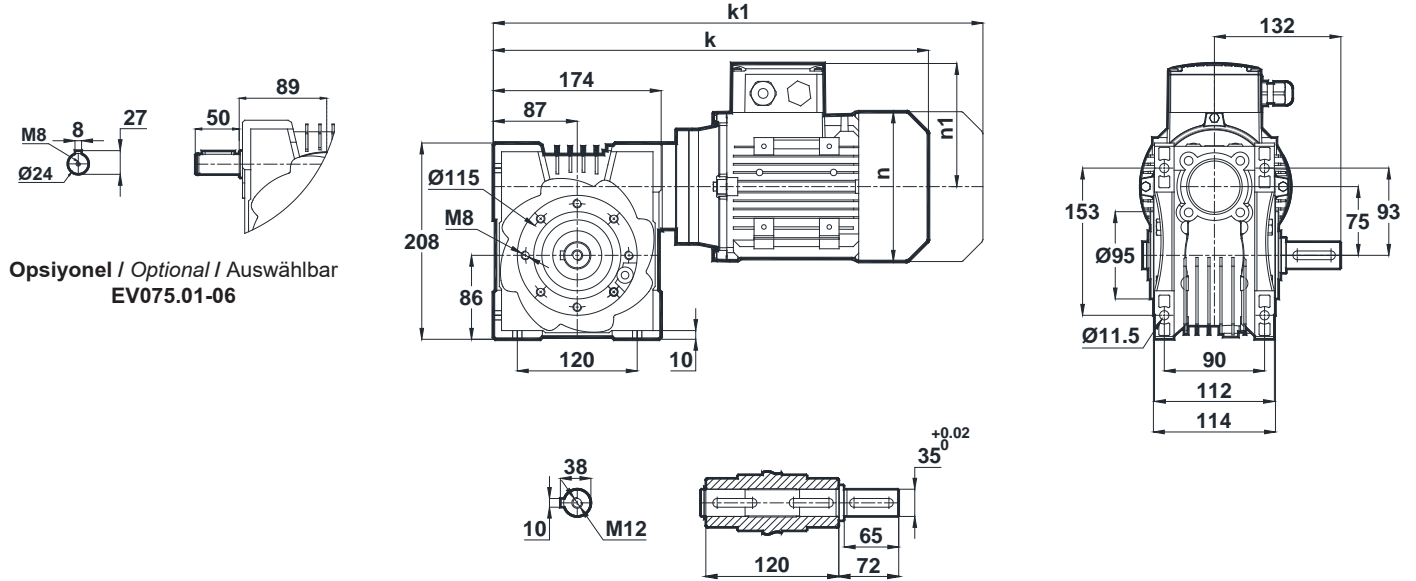

Opsiyonel / Optional / Auswählbar  
EV075.01-06

#### Klemens Pozisyonları / Terminal Box Positions / Klemmenkasten

IEC B14 / B5	80	90S	90L	100L	112M
k	434.5	475.5	475.5	511	531.5
k1	527.5	579	579	619.5	636
n	155	176	176	193	215
n1	121	133	133	147	158

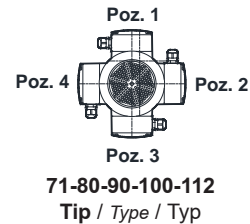

Motorlar B14 flanş ile bağlanmıştır. / Motor connections are with IEC B14 Flange / Motorbefestigung mit IEC B14 Flansch.  
"k1" Ölçüsü frenli redüktörlere aittir. 56 tip elektrik motorlu redüktörler soğutmasız, diğerleri soğutmalıdır.  
Dimensions "k1" is for motors with brake. Gearboxes with 56 type electrical motors are not fan cooled, other types are fan cooled.  
Maße "k1" ist für Bremsenmotoren. Getriebe mit 56 Motortypen sind ohne Kühlung, andere Typen sind mit Ventilator gekühlt.

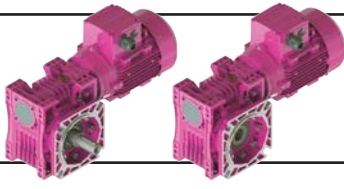

# Ölçü Sayfaları

## Dimension Pages

### Abmessungsseiten

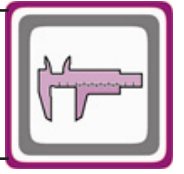

-Mil ucu çekirme deliği DIN 332 sayfa 2 / Tapped center hole to DIN 332, sheet 2 / Zentrierung mit Gewinde DIN 332, Blatt 2

#### EV075.02

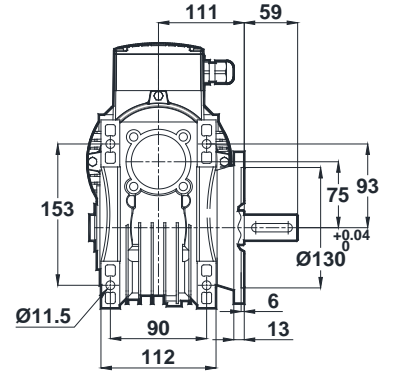
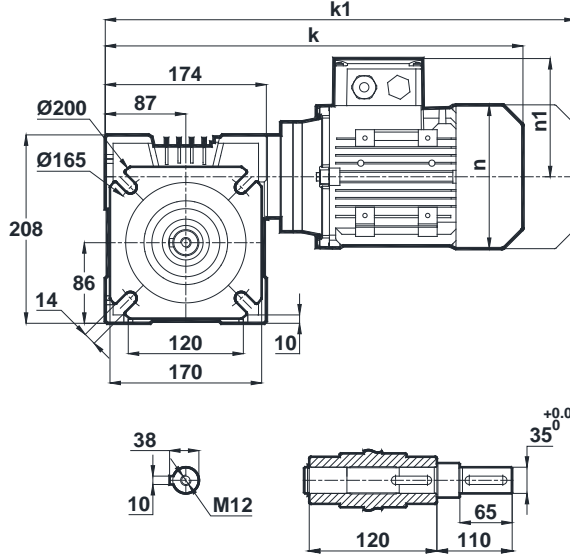
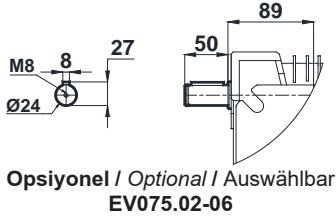

#### EV075.03

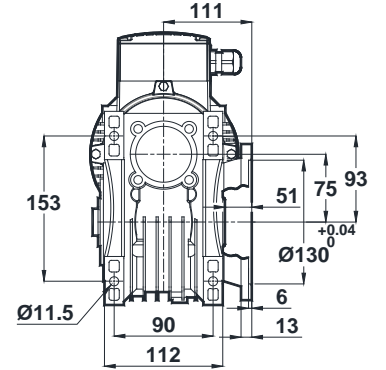
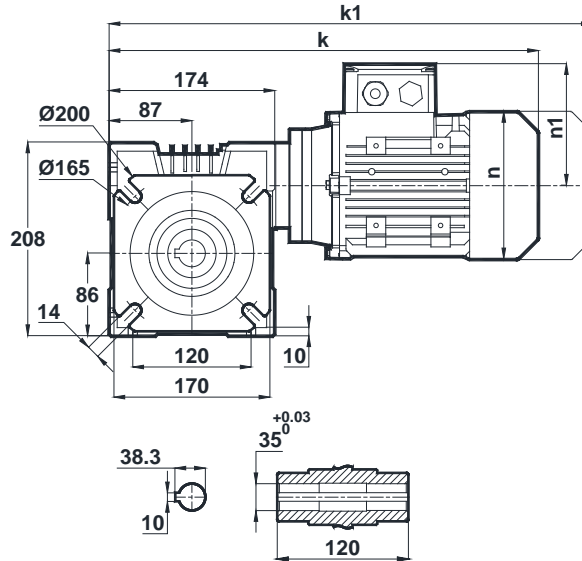
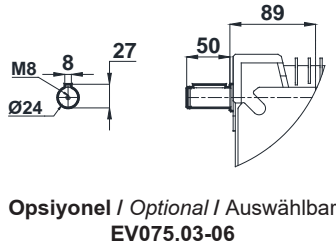

IEC B14 / B5	80	90S	90L	100L	112M
k	434.5	475.5	475.5	511	531.5
k1	527.5	579	579	619.5	636
n	155	176	176	193	215
n1	121	133	133	147	158

#### Klemens Pozisyonları / Terminal Box Positions / Klemmenkasten

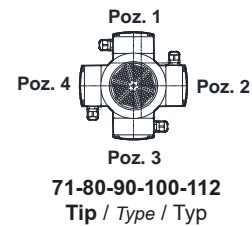

Motorlar B14 flanş ile bağlanmıştır. / Motor connections are with IEC B14 Flange / Motorbefestigung mit IEC B14 Flansch.  
"k1" Ölçüsü frenli redüktörlere aittir. 56 tip elektrik motorlu redüktörler soğutmasız, diğerleri soğutmalıdır.  
Dimensions "k1" is for motors with brake. Gearboxes with 56 type electrical motors are not fan cooled, other types are fan cooled.  
Maße "k1" sind für Bremsenmotoren. Getriebe mit 56 Motortypen sind ohne Kühlung, andere Typen sind mit Ventilator gekühlt.

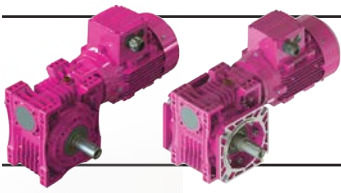

# Ölçü Sayfaları

## Dimension Pages

### Abmessungsseiten



-Mil ucu çekirme deliği DIN 332 sayfa 2 / Tapped center hole to DIN 332, sheet 2 / Zentrierung mit Gewinde DIN 332, Blatt 2

#### EV075.04

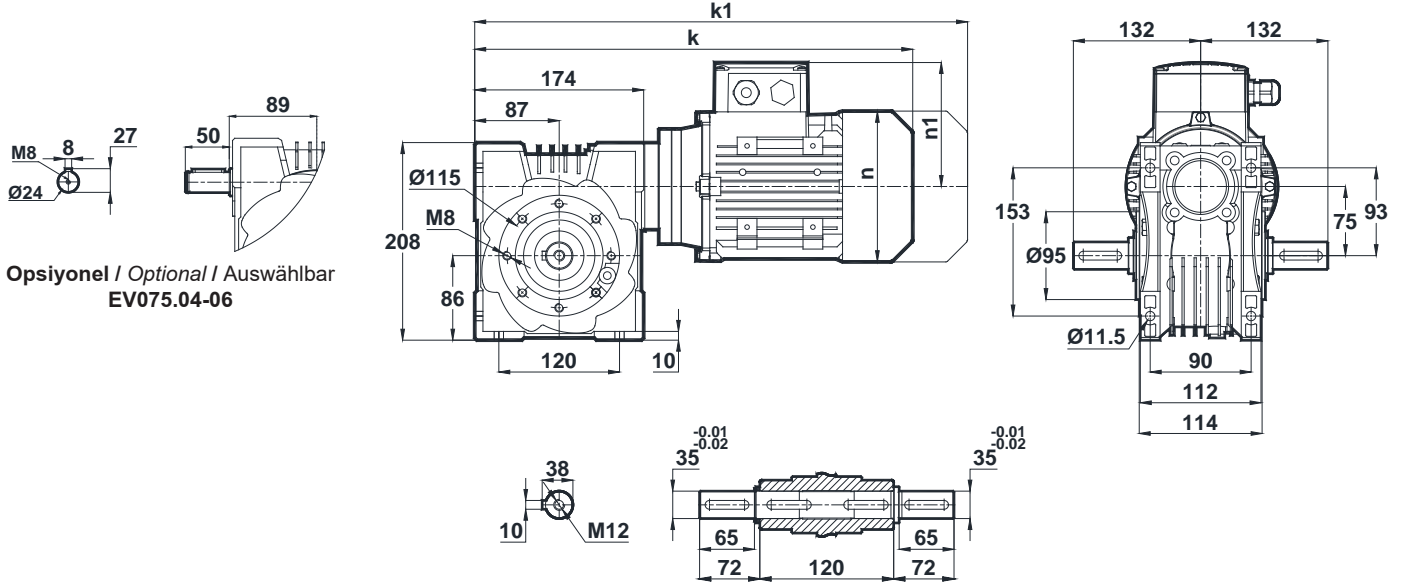

#### EV075.05

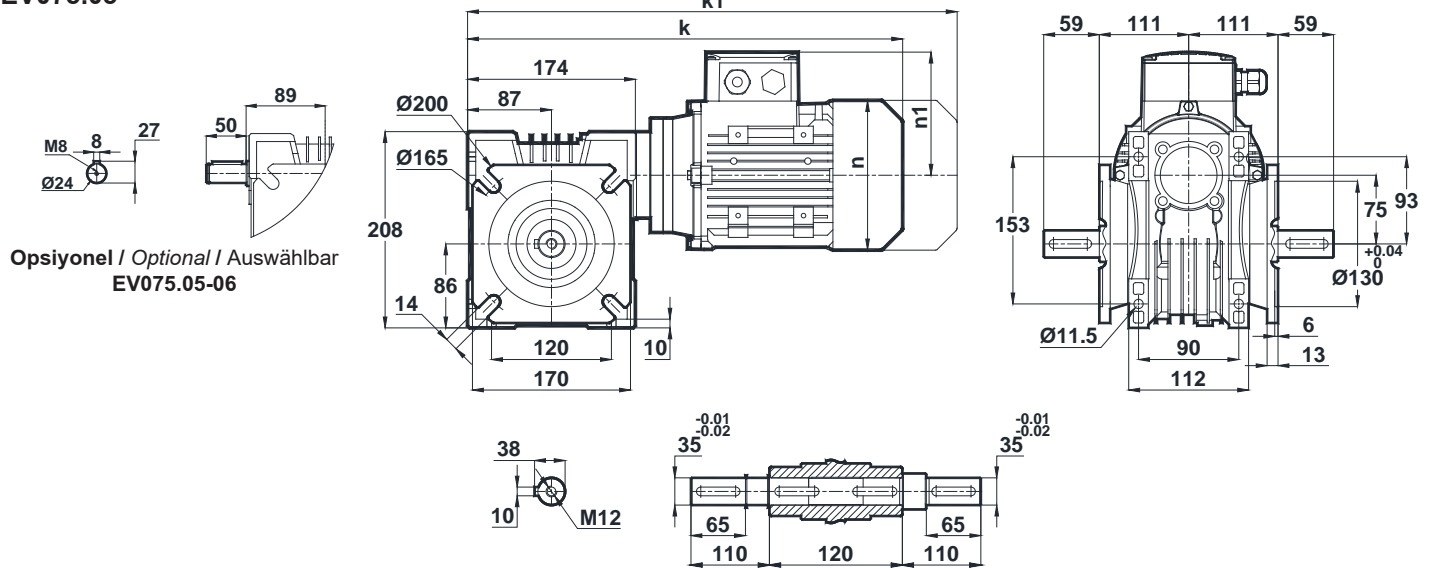

#### Klemens Pozisyonları / Terminal Box Positions / Klemmenkasten

IEC B14 / B5	80	90S	90L	100L	112M
k	434.5	475.5	475.5	511	531.5
k1	527.5	579	579	619.5	636
n	155	176	176	193	215
n1	121	133	133	147	158

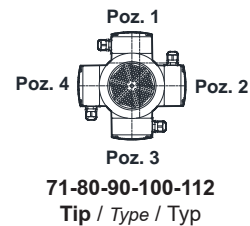

Motorlar B14 flanş ile bağlanmıştır. / Motor connections are with IEC B14 Flange / Motorbefestigung mit IEC B14 Flansch.

"k1" Ölçüsü frenli redüktörlere aittir. 56 tip elektrik motorlu redüktörler soğutmasız, diğerleri soğutmalıdır.

Dimensions "k1" is for motors with brake. Gearboxes with 56 type electrical motors are not fan cooled, other types are fan cooled.

Maße "k1" ist für Bremsenmotoren. Getriebe mit 56 Motortypen sind ohne Kühlung, andere Typen sind mit Ventilator gekühlt.

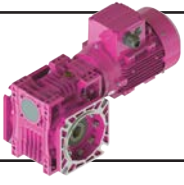

# Ölçü Sayfaları Dimension Pages Abmessungsseiten

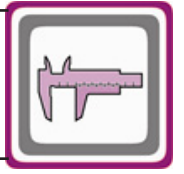

-Mil ucu çekirme deliği DIN 332 sayfa 2 / Tapped center hole to DIN 332, sheet 2 / Zentrierung mit Gewinde DIN 332, Blatt 2

EV075.08

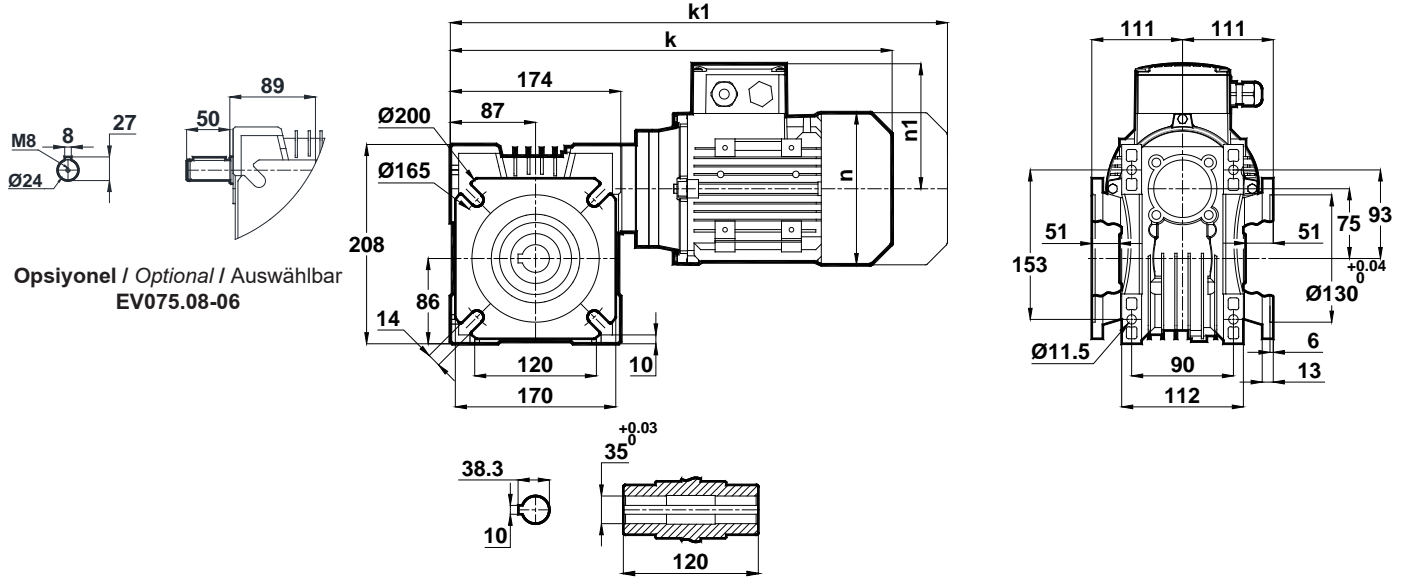

Opsiyonel / Optional / Auswählbar  
EV075.08-06

IEC B14 / B5	80	90S	90L	100L	112M
k	434.5	475.5	475.5	511	531.5
k1	527.5	579	579	619.5	636
n	155	176	176	193	215
n1	121	133	133	147	158

Klemens Pozisyonları / Terminal Box Positions / Klemmenkasten

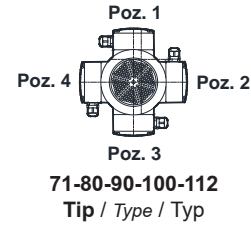

Motorlar B14 flanş ile bağlanmıştır. / Motor connections are with IEC B14 Flange / Motorbefestigung mit IEC B14 Flansch.  
"k1" Ölçüsü frenli redüktörlere aittir. 56 tip elektrik motorlu redüktörler soğutmasız, diğerleri soğutmalıdır.  
Dimensions "k1" is for motors with brake. Gearboxes with 56 type electrical motors are not fan cooled, other types are fan cooled.  
Maße "k1" sind für Bremsenmotoren. Getriebe mit 56 Motortypen sind ohne Kühlung, andere Typen sind mit Ventilator gekühlt.

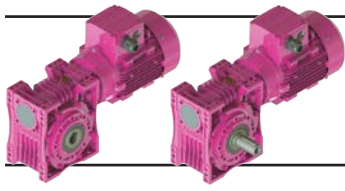

# Ölçü Sayfaları

## Dimension Pages

### Abmessungsseiten

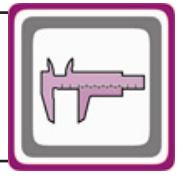

-Mil ucu çekirme deliği DIN 332 sayfa 2 / Tapped center hole to DIN 332, sheet 2 / Zentrierung mit Gewinde DIN 332, Blatt 2

#### EV080.00

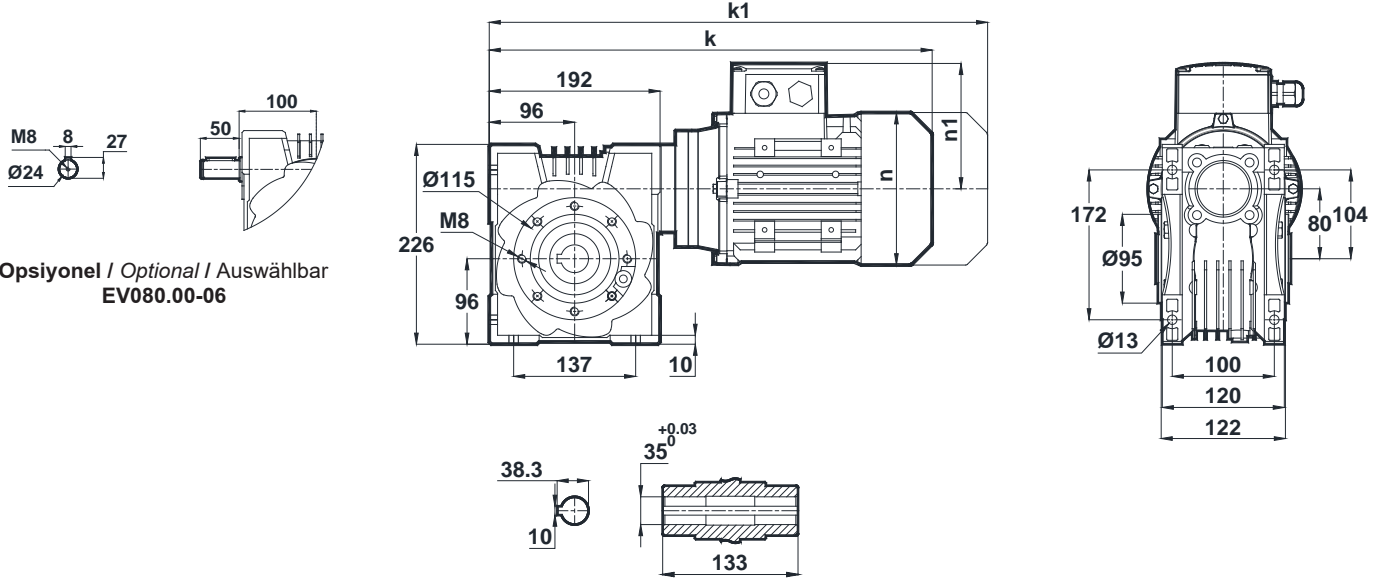

#### EV080.01

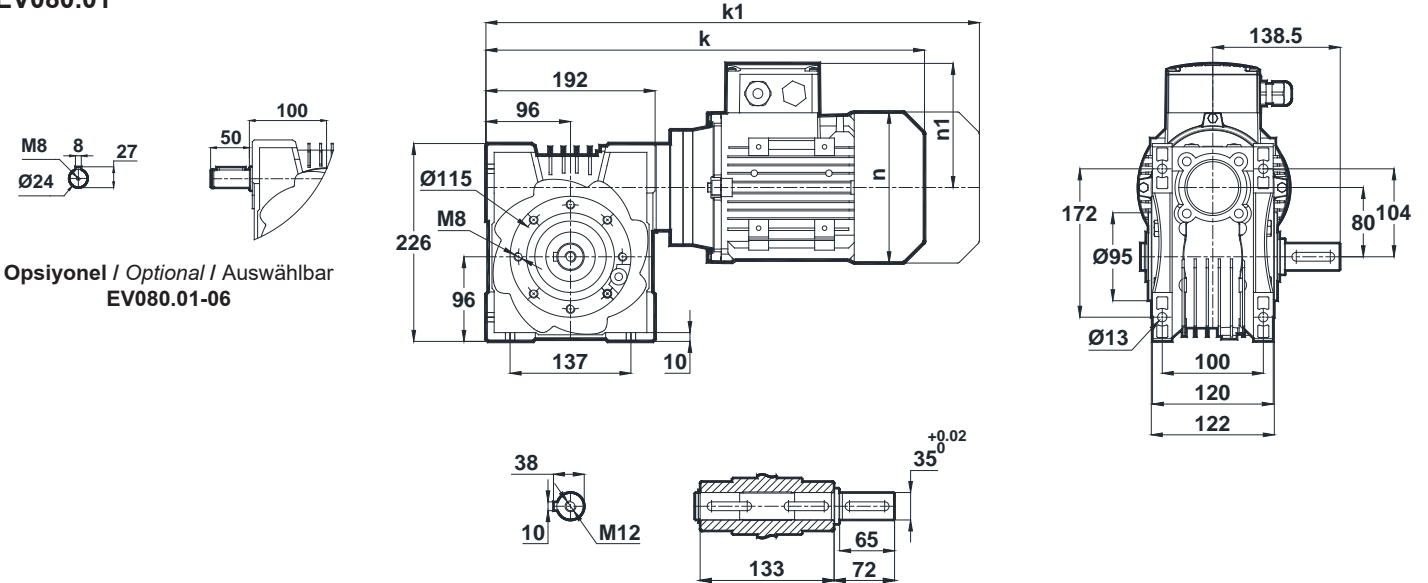

IEC B14 / B5	80	90S	90L	100L	112M
k	452.5	493.5	493.5	529	549.5
k1	545.5	597	597	637.5	654
n	155	176	176	193	215
n1	121	133	133	147	158

Klemens Pozisyonları / Terminal Box Positions / Klemmenkasten

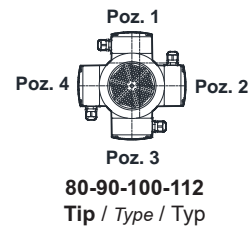

Motorlar B14 flanş ile bağlanmıştır. / Motor connections are with IEC B14 Flange / Motorbefestigung mit IEC B14 Flansch.  
"k1" Ölçüsü frenli redüktörlere aittir. 56 tip elektrik motorlu redüktörler soğutmasız, diğerleri soğutmalıdır.  
Dimensions "k1" is for motors with brake. Gearboxes with 56 type electrical motors are not fan cooled, other types are fan cooled.  
Maße "k1" ist für Bremsenmotoren. Getriebe mit 56 Motortypen sind ohne Kühlung, andere Typen sind mit Ventilator gekühlt.



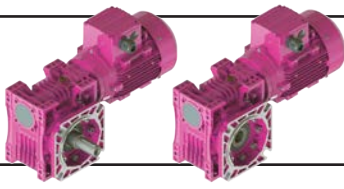

# Ölçü Sayfaları

## Dimension Pages

### Abmessungsseiten



-Mil ucu çekirme deliği DIN 332 sayfa 2 / Tapped center hole to DIN 332, sheet 2 / Zentrierung mit Gewinde DIN 332, Blatt 2

#### EV080.02

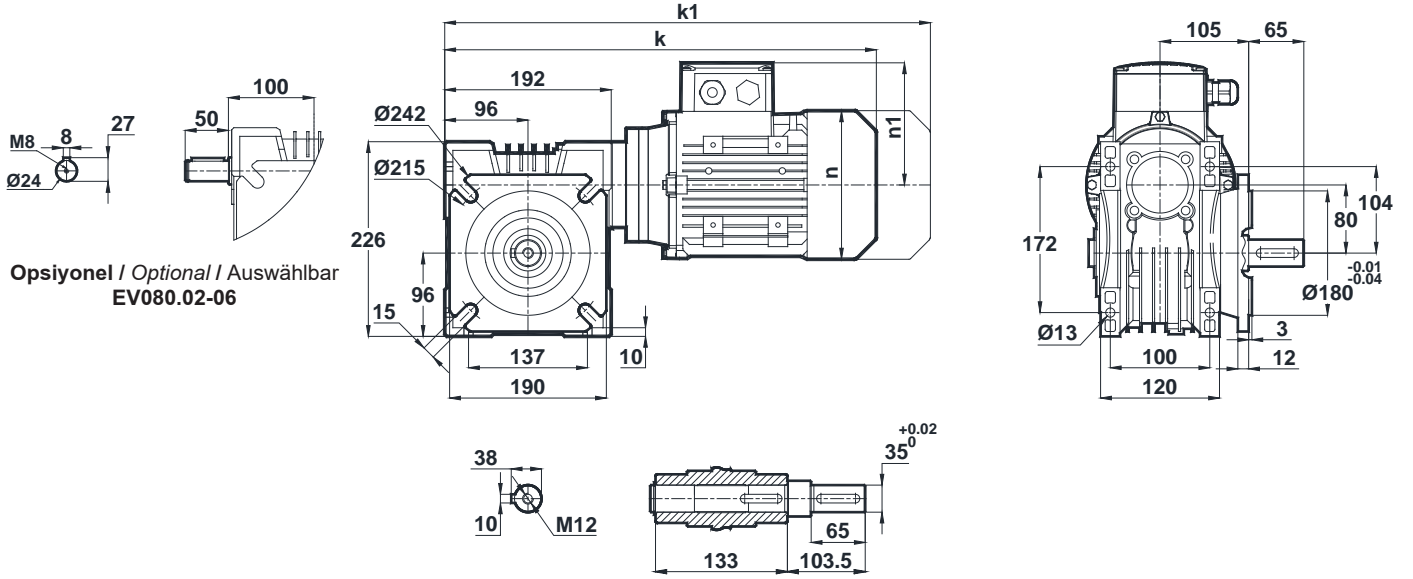

#### EV080.03

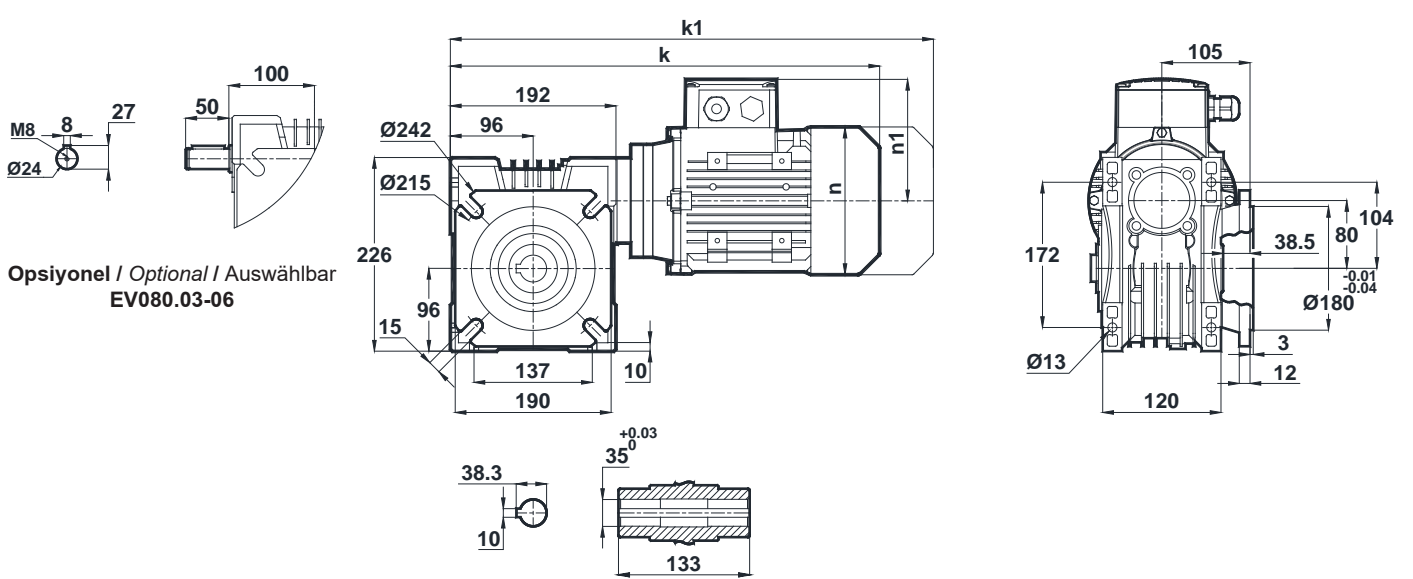

IEC B14 / B5	80	90S	90L	100L	112M
k	452.5	493.5	493.5	529	549.5
k1	545.5	597	597	637.5	654
n	155	176	176	193	215
n1	121	133	133	147	158

#### Klemens Pozisyonları / Terminal Box Positions / Klemmenkasten

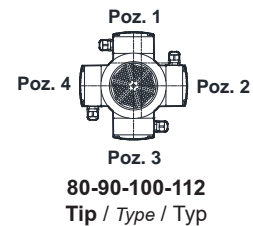

Motorlar B14 flanş ile bağlanmıştır. / Motor connections are with IEC B14 Flange / Motorbefestigung mit IEC B14 Flansch.  
"k1" Ölçüsü frenli redüktörlere aittir. 56 tip elektrik motorlu redüktörler soğutmasız, diğerleri soğutmalıdır.  
Dimensions "k1" is for motors with brake. Gearboxes with 56 type electrical motors are not fan cooled, other types are fan cooled.  
Maße "k1" sind für Bremsenmotoren. Getriebe mit 56 Motortypen sind ohne Kühlung, andere Typen sind mit Ventilator gekühlt.

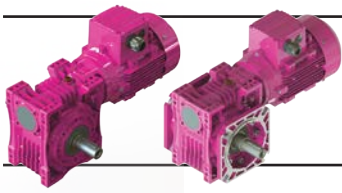

# Ölçü Sayfaları Dimension Pages Abmessungsseiten

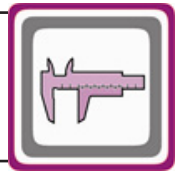

-Mil ucu çekirme deliği DIN 332 sayfa 2 / Tapped center hole to DIN 332, sheet 2 / Zentrierung mit Gewinde DIN 332, Blatt 2

## EV080.04

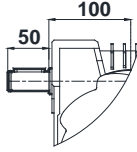
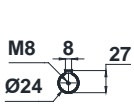

Opsiyonel / Optional / Auswählbar  
EV080.04-06

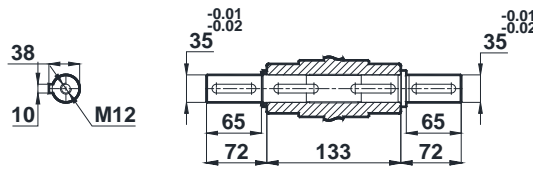
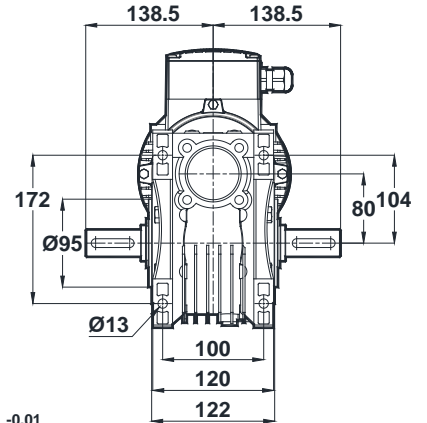
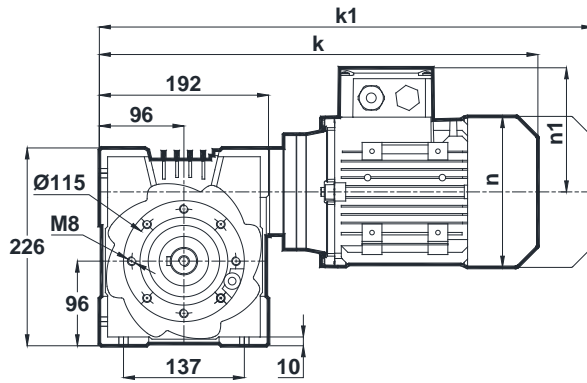

## EV080.05

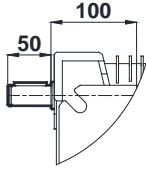
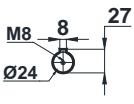

Opsiyonel / Optional / Auswählbar  
EV080.05-06

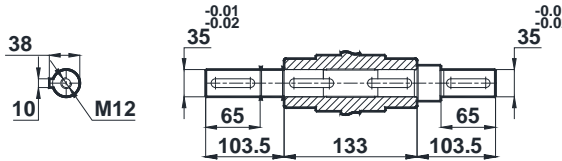
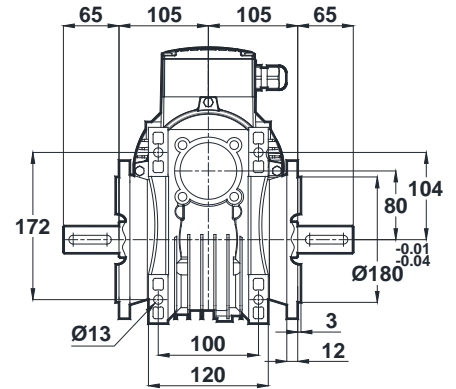
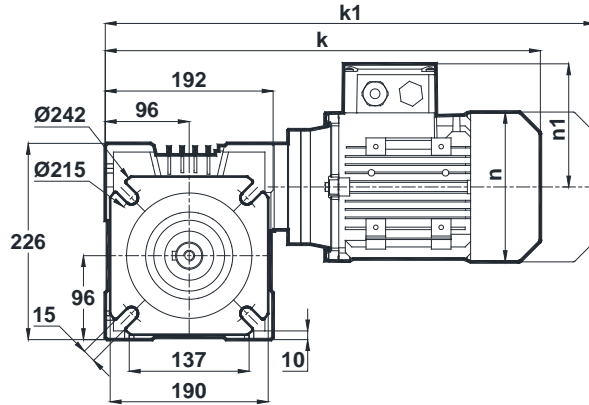

IEC B14 / B5	80	90S	90L	100L	112M
k	452.5	493.5	493.5	529	549.5
k1	545.5	597	597	637.5	654
n	155	176	176	193	215
n1	121	133	133	147	158

Klemens Pozisyonları / Terminal Box Positions / Klemmenkasten

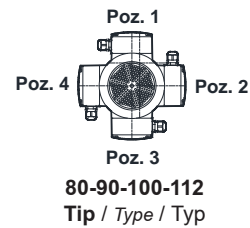

Motorlar B14 flanş ile bağlanmıştır. / Motor connections are with IEC B14 Flange / Motorbefestigung mit IEC B14 Flansch.  
"k1" Ölçüsü frenli redüktörlere aittir. 56 tip elektrik motorlu redüktörler soğutmasız, diğerleri soğutmalıdır.  
Dimensions "k1" is for motors with brake. Gearboxes with 56 type electrical motors are not fan cooled, other types are fan cooled.  
Maße "k1" ist für Bremsenmotoren. Getriebe mit 56 Motortypen sind ohne Kühlung, andere Typen sind mit Ventilator gekühlt.

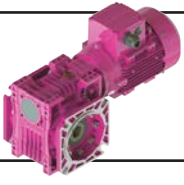

# Ölçü Sayfaları Dimension Pages Abmessungsseiten



-Mil ucu çekirme deliği DIN 332 sayfa 2 / Tapped center hole to DIN 332, sheet 2 / Zentrierung mit Gewinde DIN 332, Blatt 2

EV080.08

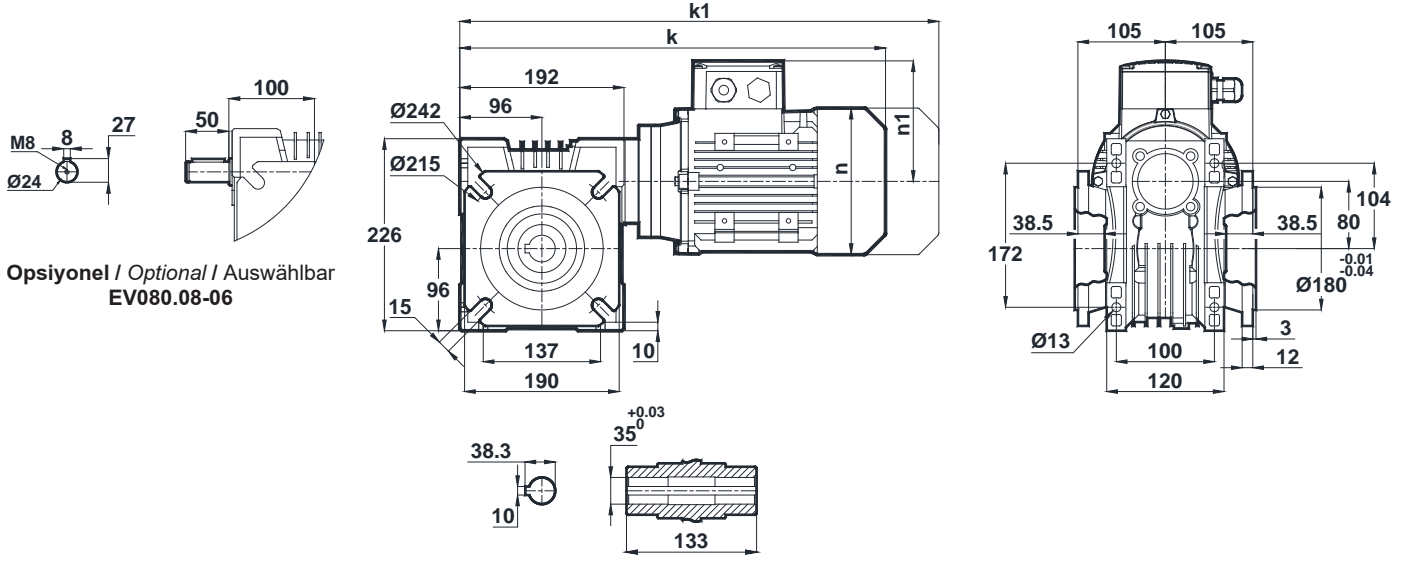

Opsiyonel / Optional / Auswählbar  
EV080.08-06

IEC B14 / B5	80	90S	90L	100L	112M
k	452.5	493.5	493.5	529	549.5
k1	545.5	597	597	637.5	654
n	155	176	176	193	215
n1	121	133	133	147	158

Klemens Pozisyonları / Terminal Box Positions / Klemmenkasten

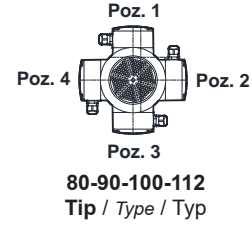

Motorlar B14 flanş ile bağlanmıştır. / Motor connections are with IEC B14 Flange / Motorbefestigung mit IEC B14 Flansch.

"k1" Ölçüsü frenli redüktörlere aittir. 56 tip elektrik motorlu redüktörler soğutmasız, diğerleri soğutmalıdır.

Dimensions "k1" is for motors with brake. Gearboxes with 56 type electrical motors are not fan cooled, other types are fan cooled.

Maße "k1" sind für Bremsenmotoren. Getriebe mit 56 Motortypen sind ohne Kühlung, andere Typen sind mit Ventilator gekühlt.

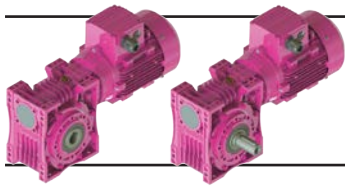

# Ölçü Sayfaları

## Dimension Pages

### Abmessungsseiten

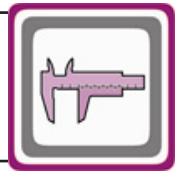

-Mil ucu çekirme deliği DIN 332 sayfa 2 / Tapped center hole to DIN 332, sheet 2 / Zentrierung mit Gewinde DIN 332, Blatt 2

#### EV100.00

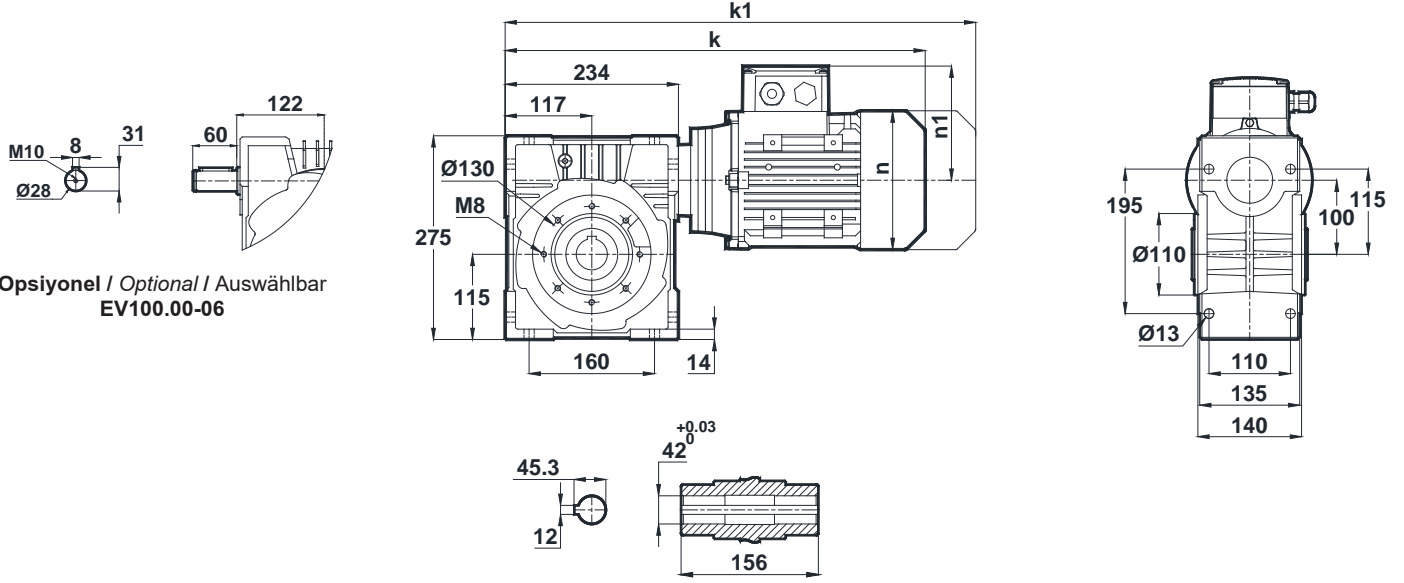

Opsiyonel / Optional / Auswählbar  
EV100.00-06

#### EV100.01

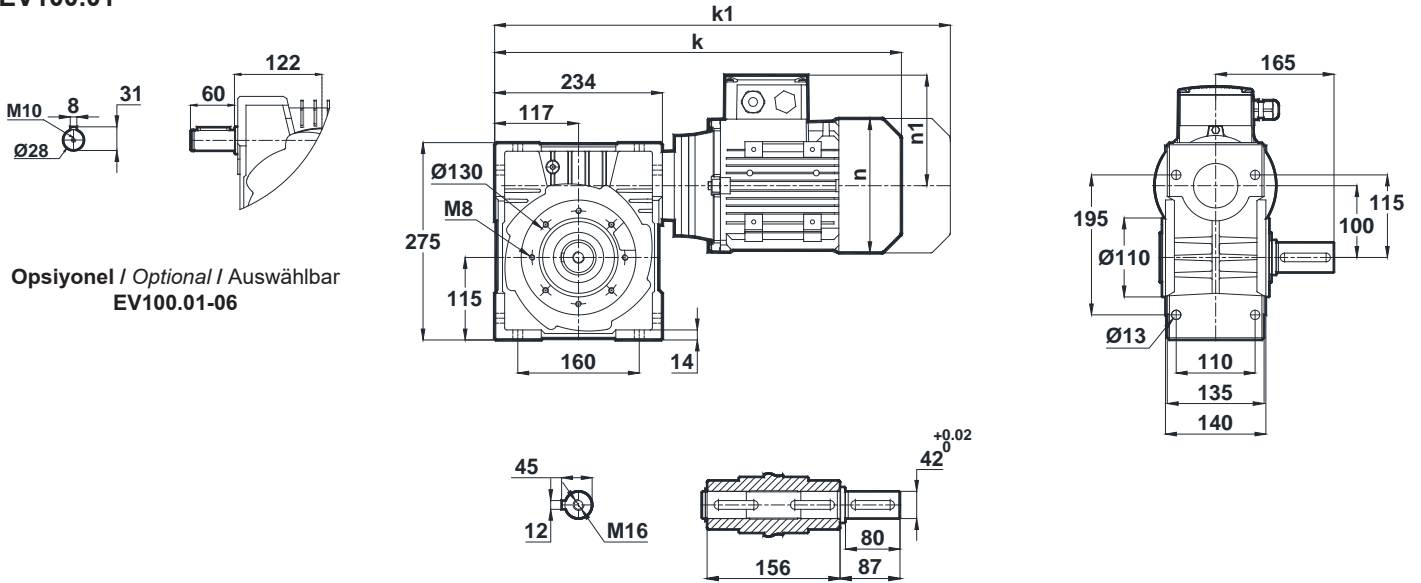

Opsiyonel / Optional / Auswählbar  
EV100.01-06

IEC B14 / B5	80	90S	90L	100L	112M
k	494.5	535.5	535.5	571	591.5
k1	587.5	639	639	679.5	696
n	155	176	176	193	215
n1	121	133	133	147	158

#### Klemens Pozisyonları

##### Terminal Box Positions

##### Klemmenkasten

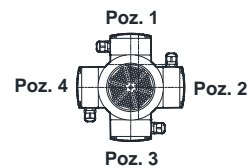

80-90-100-112  
Tip / Type / Typ

Motorlar B14 flanş ile bağlanmıştır. / Motor connections are with IEC B14 Flange / Motorbefestigung mit IEC B14 Flansch.  
"k1" Ölçüsü frenli redüktörlere aittir. 56 tip elektrik motorlu redüktörler soğutmasız, diğerleri soğutmalıdır.  
Dimensions "k1" is for motors with brake. Gearboxes with 56 type electrical motors are not fan cooled, other types are fan cooled.  
Maße "k1" ist für Bremsenmotoren. Getriebe mit 56 Motortypen sind ohne Kühlung, andere Typen sind mit Ventilator gekühlt.

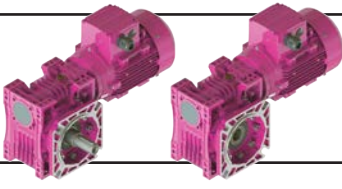

# Ölçü Sayfaları

## Dimension Pages

### Abmessungsseiten



-Mil ucu çekirme deliği DIN 332 sayfa 2 / Tapped center hole to DIN 332, sheet 2 / Zentrierung mit Gewinde DIN 332, Blatt 2

#### EV100.02

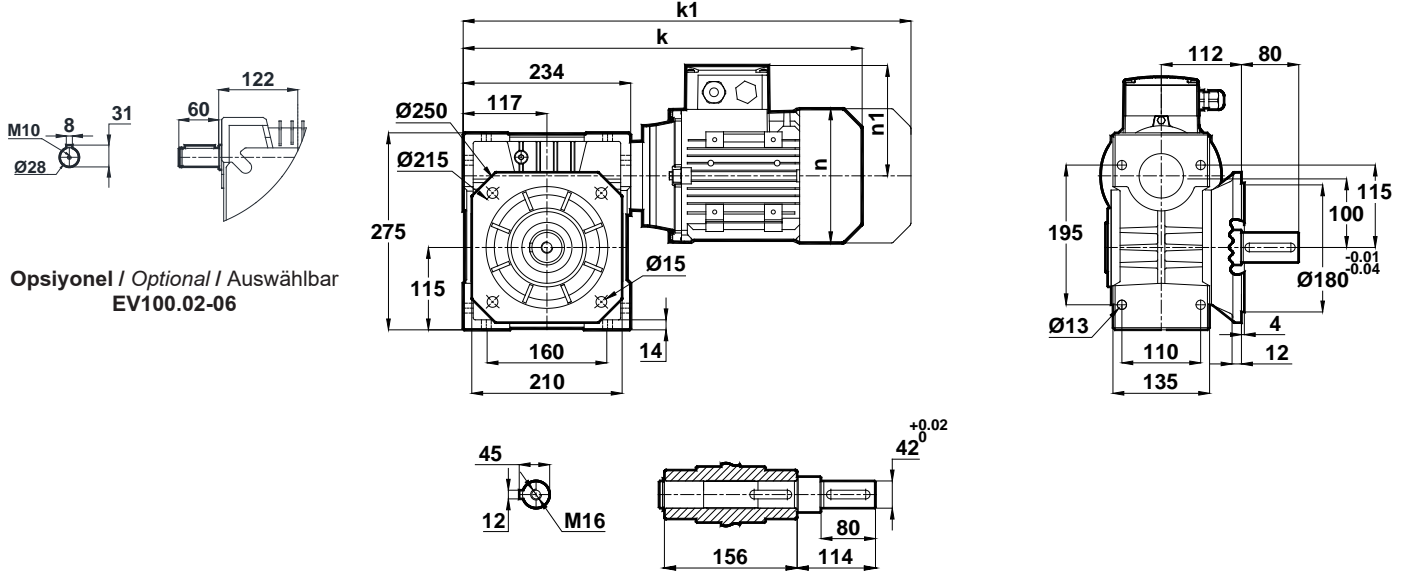

#### EV100.03

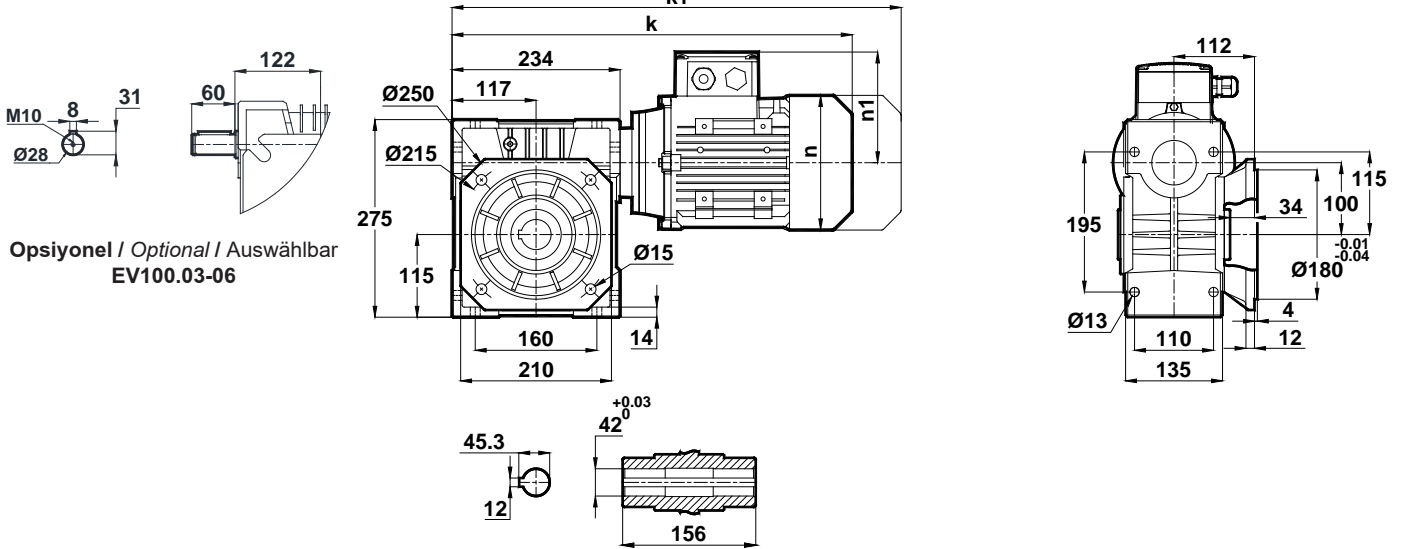

IEC B14 / B5	80	90S	90L	100L	112M
k	494.5	535.5	535.5	571	591.5
k1	587.5	639	639	679.5	696
n	155	176	176	193	215
n1	121	133	133	147	158

#### Klemens Pozisyonları

##### Terminal Box Positions

##### Klemmenkasten

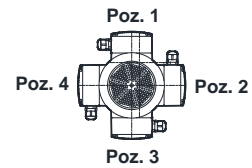

80-90-100-112  
Tip / Type / Typ

Motorlar B14 flanş ile bağlanmıştır. / Motor connections are with IEC B14 Flange / Motorbefestigung mit IEC B14 Flansch.

"k1" Ölçüsü frenli redüktörlere aittir. 56 tip elektrik motorlu redüktörler soğutmasız, diğerleri soğutmalıdır.

Dimensions "k1" is for motors with brake. Gearboxes with 56 type electrical motors are not fan cooled, other types are fan cooled.

Maße "k1" sind für Bremsenmotoren. Getriebe mit 56 Motortypen sind ohne Kühlung, andere Typen sind mit Ventilator gekühlt.

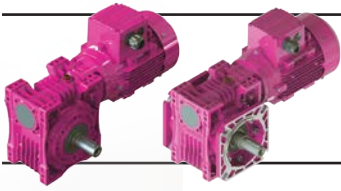

# Ölçü Sayfaları

## Dimension Pages

### Abmessungsseiten



-Mil ucu çekirme deliği DIN 332 sayfa 2 / Tapped center hole to DIN 332, sheet 2 / Zentrierung mit Gewinde DIN 332, Blatt 2

#### EV100.04

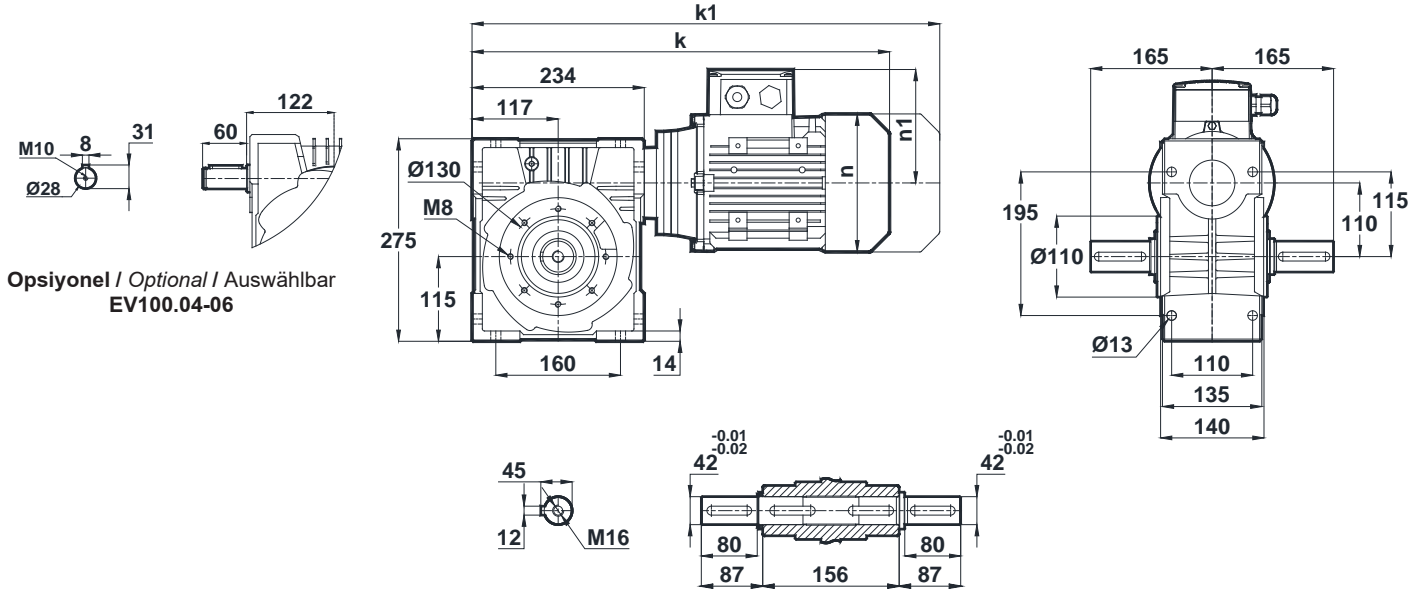

Opsiyonel / Optional / Auswählbar  
EV100.04-06

#### EV100.05

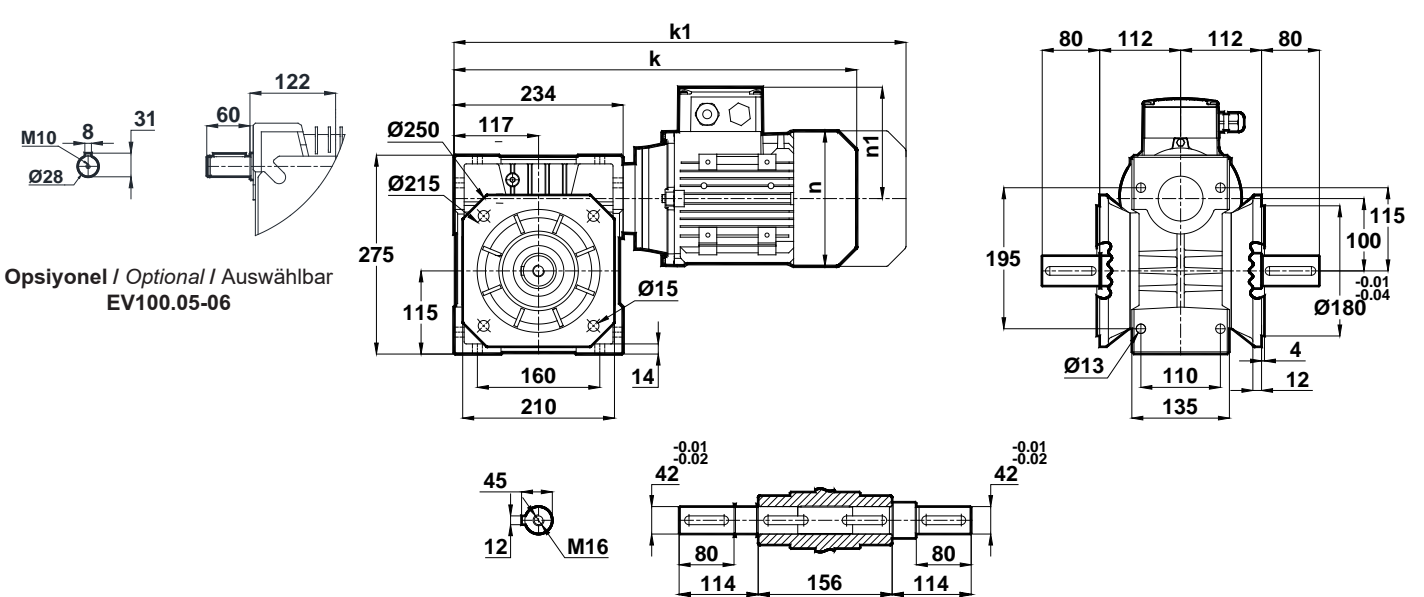

Opsiyonel / Optional / Auswählbar  
EV100.05-06

IEC B14 / B5	80	90S	90L	100L	112M
k	494.5	535.5	535.5	571	591.5
k1	587.5	639	639	679.5	696
n	155	176	176	193	215
n1	121	133	133	147	158

Klemens Pozisyonları  
Terminal Box Positions  
Klemmenkasten

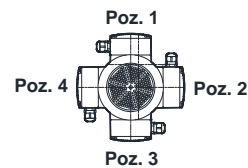

80-90-100-112  
Tip / Type / Typ

Motorlar B14 flanş ile bağlanmıştır. / Motor connections are with IEC B14 Flange / Motorbefestigung mit IEC B14 Flansch.

"k1" Ölçüsü frenli redüktörlere aittir. 56 tip elektrik motorlu redüktörler soğutmasız, diğerleri soğutmalıdır.

Dimensions "k1" is for motors with brake. Gearboxes with 56 type electrical motors are not fan cooled, other types are fan cooled.

Maße "k1" ist für Bremsenmotoren. Getriebe mit 56 Motortypen sind ohne Kühlung, andere Typen sind mit Ventilator gekühlt.

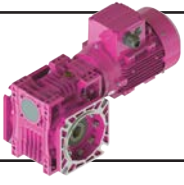

# Ölçü Sayfaları

## Dimension Pages

### Abmessungsseiten

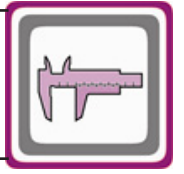

-Mil ucu çekirme deliği DIN 332 sayfa 2 / Tapped center hole to DIN 332, sheet 2 / Zentrierung mit Gewinde DIN 332, Blatt 2

EV100.08

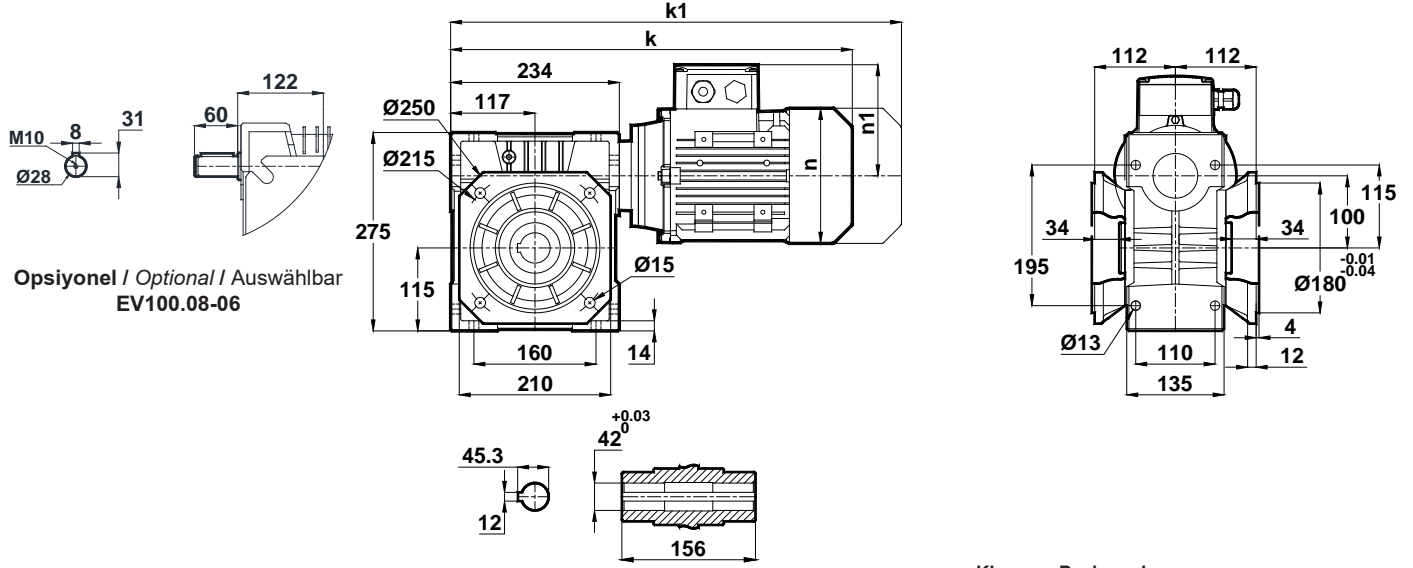

IEC B14 / B5	80	90S	90L	100L	112M
k	494.5	535.5	535.5	571	591.5
k1	587.5	639	639	679.5	696
n	155	176	176	193	215
n1	121	133	133	147	158

Klemens Pozisyonları  
Terminal Box Positions  
Klemmenkasten

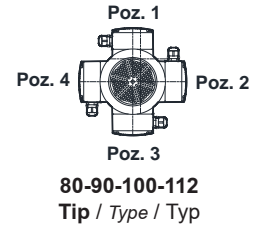

80-90-100-112  
Tip / Type / Typ

Motorlar B14 flanş ile bağlanmıştır. / Motor connections are with IEC B14 Flange / Motorbefestigung mit IEC B14 Flansch.

"k1" Ölçüsü frenli redüktörlere aittir. 56 tip elektrik motorlu redüktörler soğutmasız, diğerleri soğutmalıdır.

Dimensions "k1" is for motors with brake. Gearboxes with 56 type electrical motors are not fan cooled, other types are fan cooled.

Maße "k1" sind für Bremsenmotoren. Getriebe mit 56 Motortypen sind ohne Kühlung, andere Typen sind mit Ventilator gekühlt.

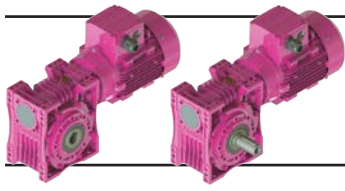

# Ölçü Sayfaları

## Dimension Pages

### Abmessungsseiten

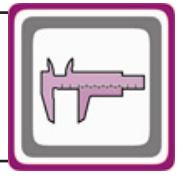

-Mil ucu çekirme deliği DIN 332 sayfa 2 / Tapped center hole to DIN 332, sheet 2 / Zentrierung mit Gewinde DIN 332, Blatt 2

#### EV125.00

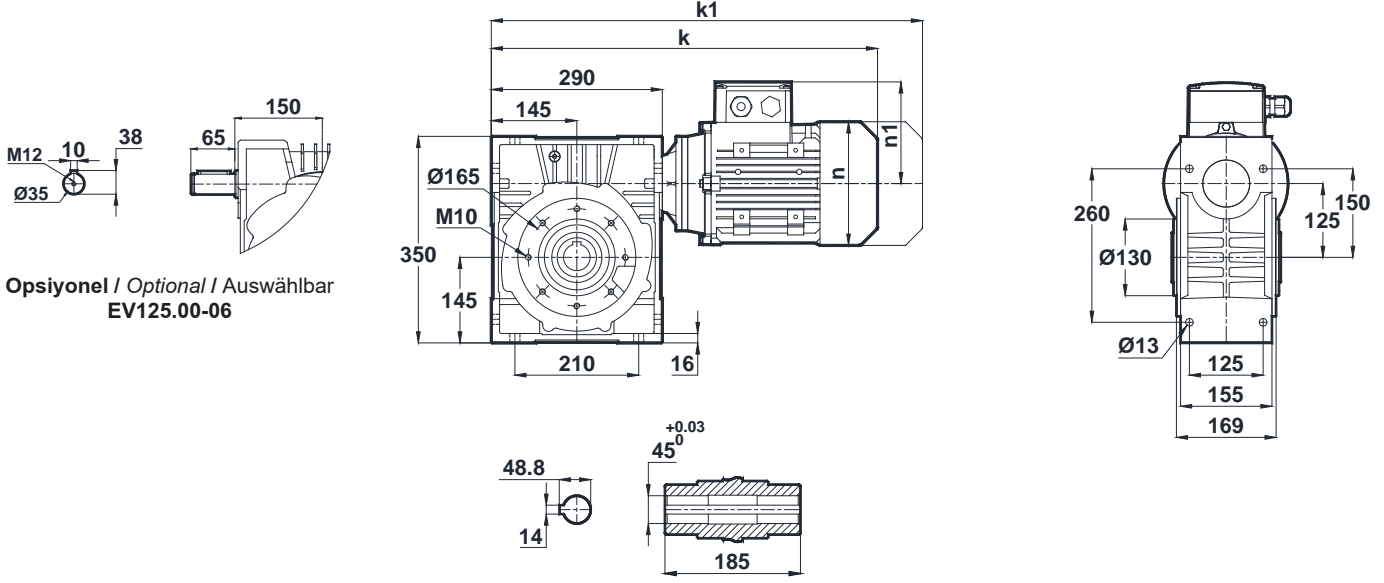

Opsiyonel / Optional / Auswählbar  
EV125.00-06

#### EV125.01

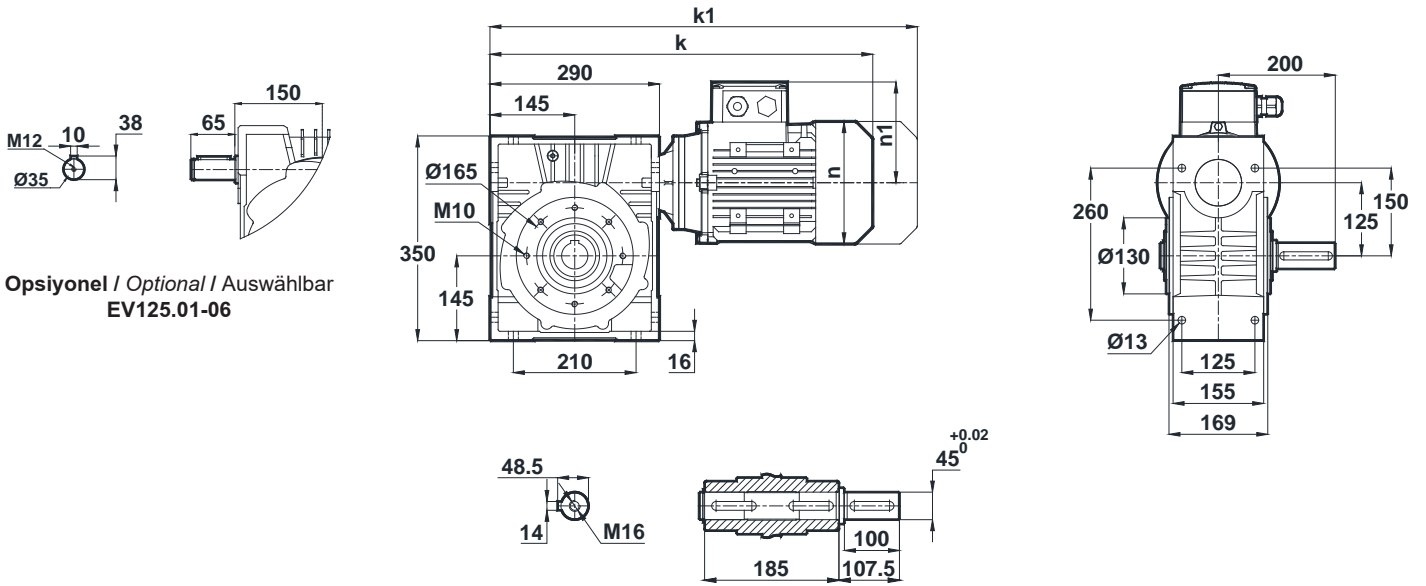

Opsiyonel / Optional / Auswählbar  
EV125.01-06

IEC	90S/B5	90L/B5	100L/B14	112M/B14	132S/B14	132M/B14
k	598	598	633.5	654	738	738
k1	701.5	701.5	742	758.5	868	868
n	176	176	193	215	257	257
n1	133	133	147	158	179	179

Klemens Pozisyonları / Terminal Box Positions / Klemmenkasten

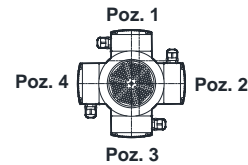

90-100-112-132  
Tip / Type / Typ

Motorlar B14 flanş ile bağlanmıştır. / Motor connections are with IEC B14 Flange / Motorbefestigung mit IEC B14 Flansch.  
"k1" Ölçüsü frenli redüktörlere aittir. 56 tip elektrik motorlu redüktörler soğutmasız, diğerleri soğutmalıdır.  
Dimensions "k1" is for motors with brake. Gearboxes with 56 type electrical motors are not fan cooled, other types are fan cooled.  
Maße "k1" ist für Bremsenmotoren. Getriebe mit 56 Motortypen sind ohne Kühlung, andere Typen sind mit Ventilator gekühlt.



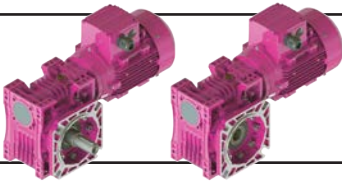

# Ölçü Sayfaları

## Dimension Pages

### Abmessungsseiten



-Mil ucu çekirme deliği DIN 332 sayfa 2 / Tapped center hole to DIN 332, sheet 2 / Zentrierung mit Gewinde DIN 332, Blatt 2

#### EV125.02

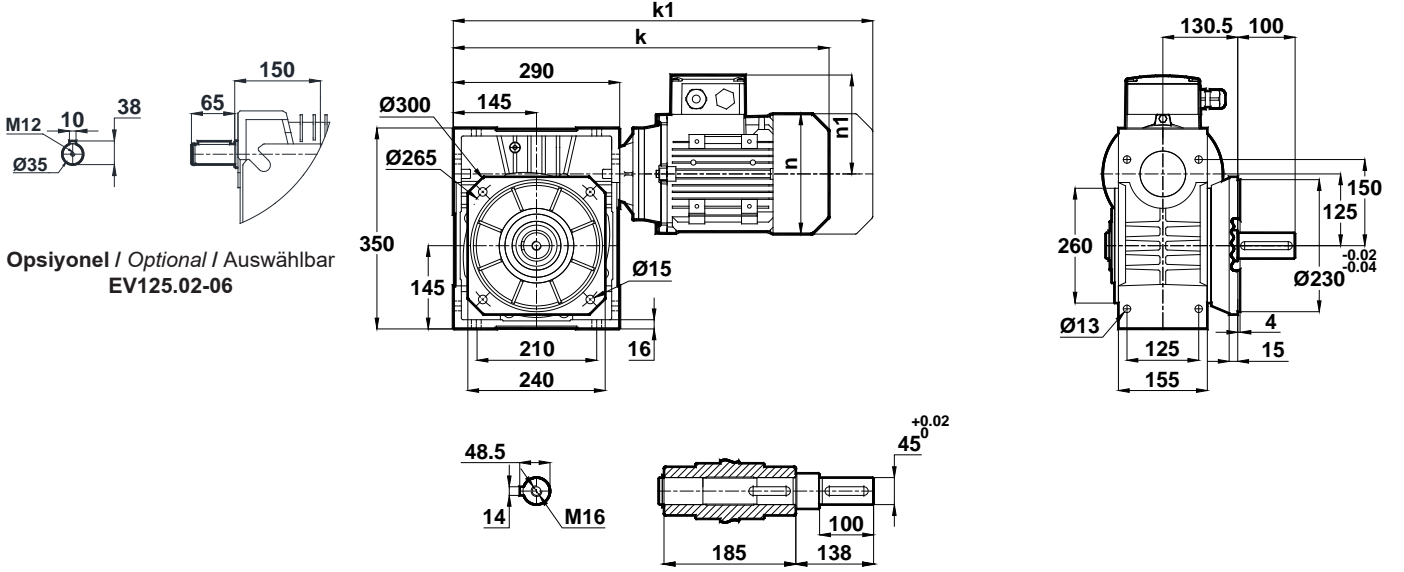

Opsiyonel / Optional / Auswählbar  
EV125.02-06

#### EV125.03

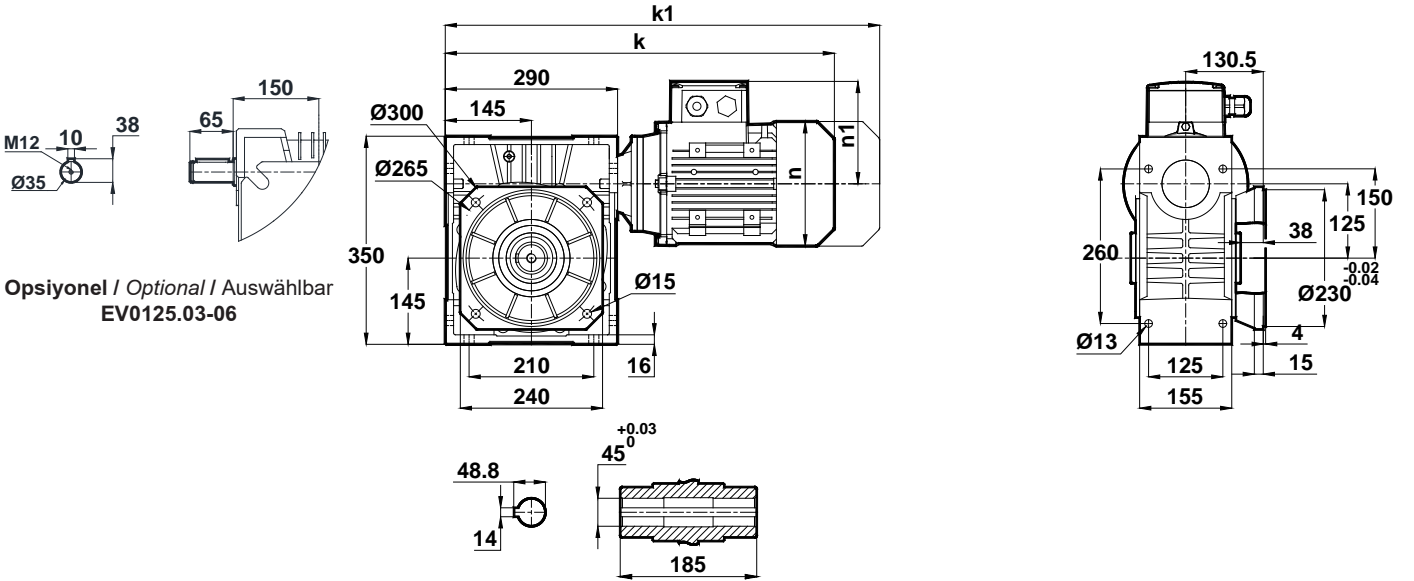

Opsiyonel / Optional / Auswählbar  
EV125.03-06

IEC	90S/B5	90L/B5	100L/B14	112M/B14	132S/B14	132M/B14
k	598	598	633.5	654	738	738
k1	701.5	701.5	742	758.5	868	868
n	176	176	193	215	257	257
n1	133	133	147	158	179	179

Klemens Pozisyonları / Terminal Box Positions / Klemmenkasten

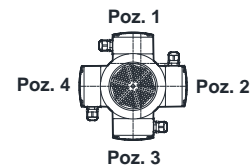

90-100-112-132  
Tip / Type / Typ

Motorlar B14 flanş ile bağlanmıştır. / Motor connections are with IEC B14 Flange / Motorbefestigung mit IEC B14 Flansch.

"k1" Ölçüsü frenli redüktörlere aittir. 56 tip elektrik motorlu redüktörler soğutmasız, diğerleri soğutmalıdır.

Dimensions "k1" is for motors with brake. Gearboxes with 56 type electrical motors are not fan cooled, other types are fan cooled.

Maße "k1" sind für Bremsenmotoren. Getriebe mit 56 Motortypen sind ohne Kühlung, andere Typen sind mit Ventilator gekühlt.

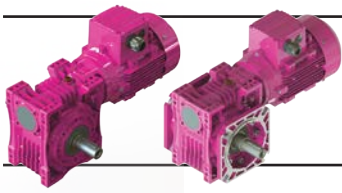

# Ölçü Sayfaları

## Dimension Pages

### Abmessungsseiten

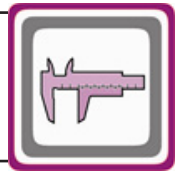

-Mil ucu çekirme deliği DIN 332 sayfa 2 / Tapped center hole to DIN 332, sheet 2 / Zentrierung mit Gewinde DIN 332, Blatt 2

#### EV125.04

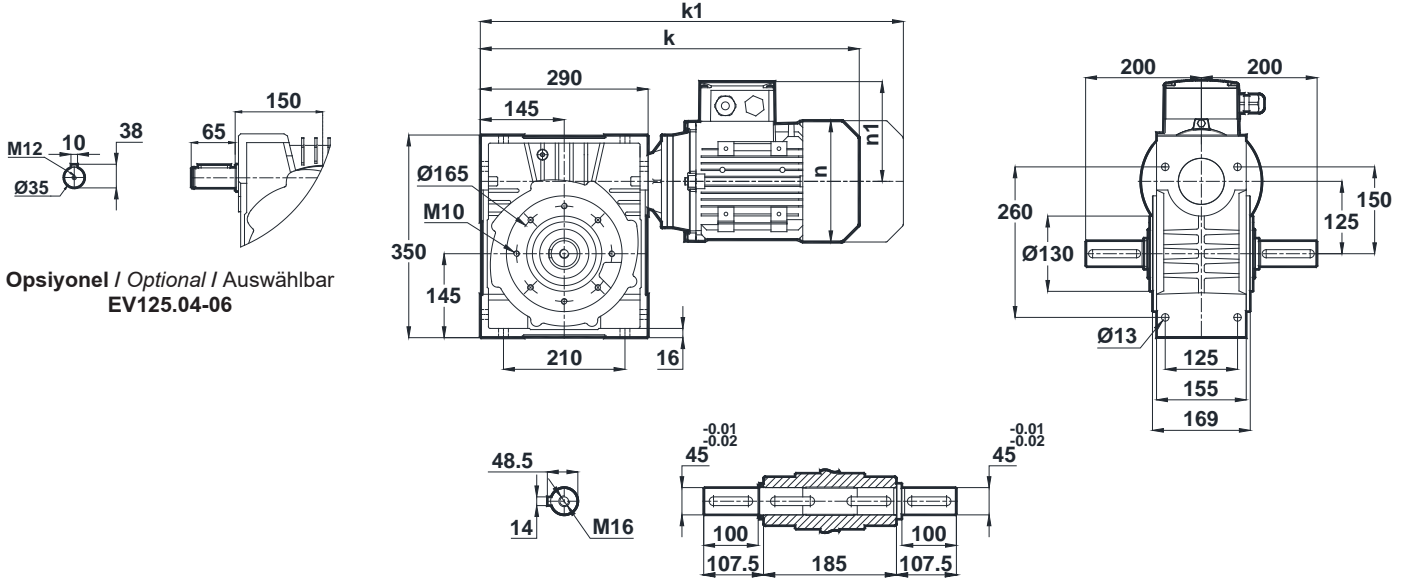

Opsiyonel / Optional / Auswählbar  
EV125.04-06

#### EV125.05

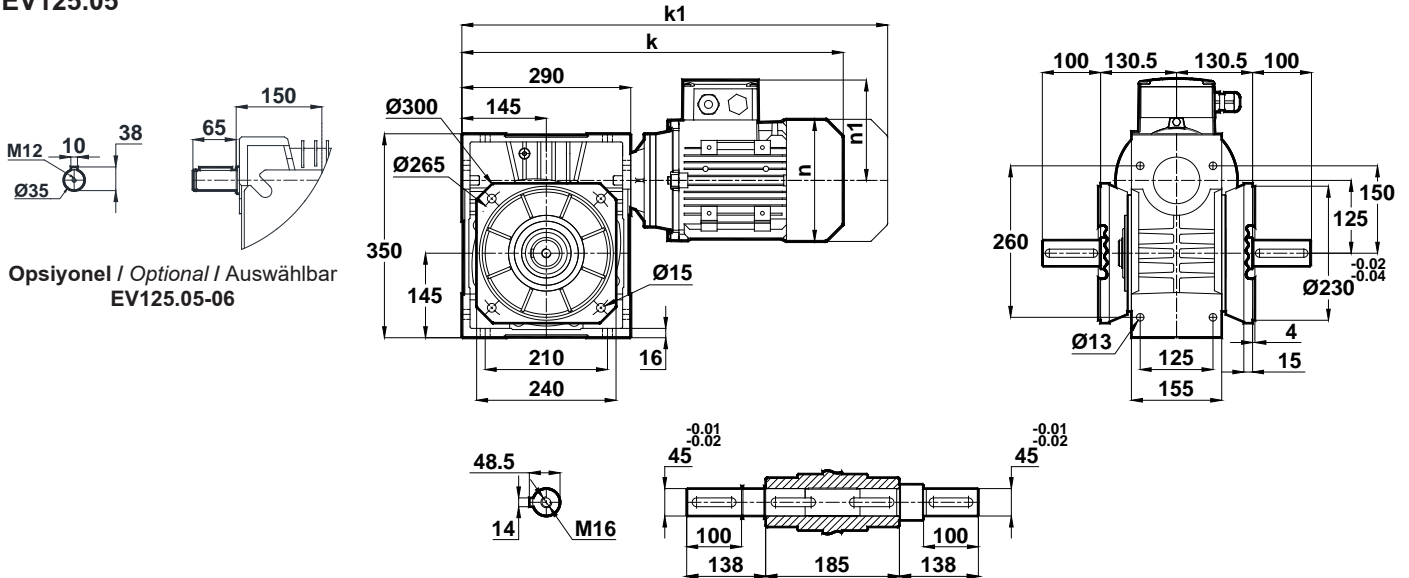

Opsiyonel / Optional / Auswählbar  
EV125.05-06

IEC	90S/B5	90L/B5	100L/B14	112M/B14	132S/B14	132M/B14
k	598	598	633.5	654	738	738
k1	701.5	701.5	742	758.5	868	868
n	176	176	193	215	257	257
n1	133	133	147	158	179	179

Klemens Pozisyonları / Terminal Box Positions / Klemmenkasten

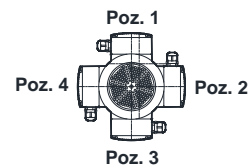

90-100-112-132  
Tip / Type / Typ

Motorlar B14 flanş ile bağlanmıştır. / Motor connections are with IEC B14 Flange / Motorbefestigung mit IEC B14 Flansch.

"k1" Ölçüsü frenli redüktörlere aittir. 56 tip elektrik motorlu redüktörler soğutmasız, diğerleri soğutmalıdır.

Dimensions "k1" is for motors with brake. Gearboxes with 56 type electrical motors are not fan cooled, other types are fan cooled.

Maße "k1" ist für Bremsenmotoren. Getriebe mit 56 Motortypen sind ohne Kühlung, andere Typen sind mit Ventilator gekühlt.

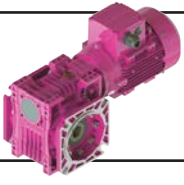

# Ölçü Sayfaları Dimension Pages Abmessungsseiten



-Mil ucu çekirme deliği DIN 332 sayfa 2 / Tapped center hole to DIN 332, sheet 2 / Zentrierung mit Gewinde DIN 332, Blatt 2

## EV125.08

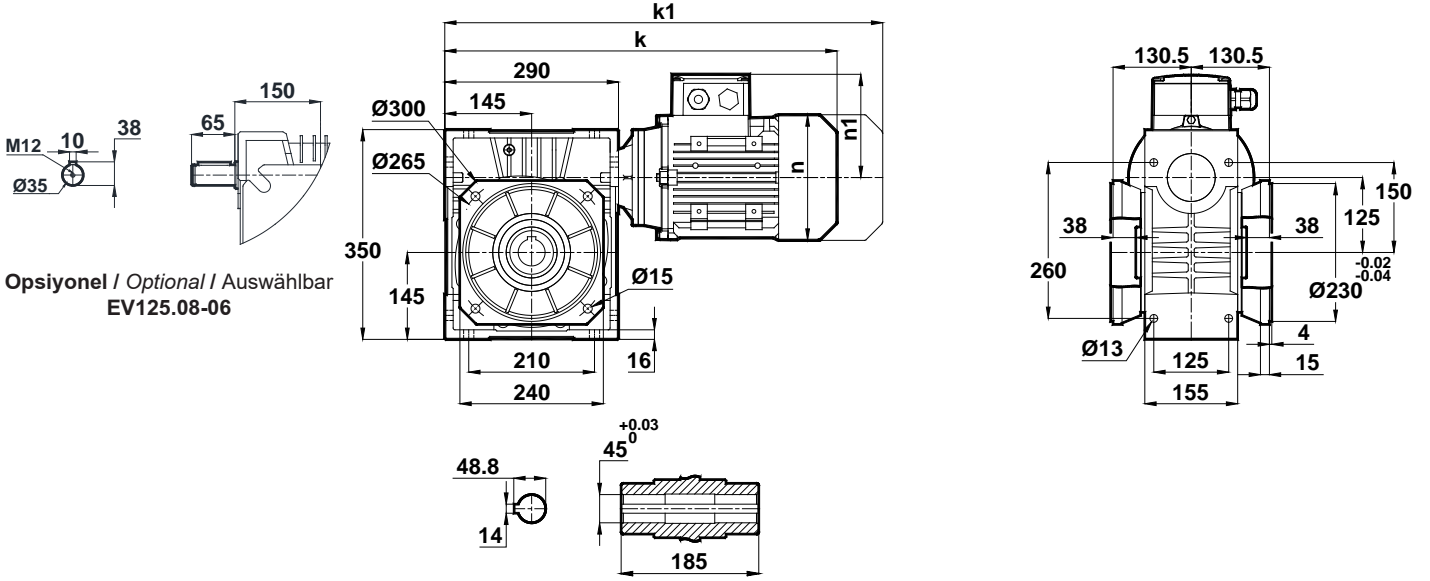

IEC	90S/B5	90L/B5	100L/B14	112M/B14	132S/B14	132M/B14
k	598	598	633.5	654	738	738
k1	701.5	701.5	742	758.5	868	868
n	176	176	193	215	257	257
n1	133	133	147	158	179	179

Klemens Pozisyonları / Terminal Box Positions / Klemmenkasten

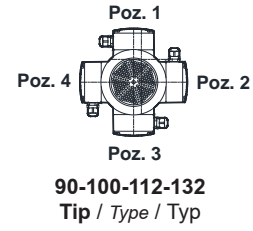

Motorlar B14 flanş ile bağlanmıştır. / Motor connections are with IEC B14 Flange / Motorbefestigung mit IEC B14 Flansch.

"k1" Ölçüsü frenli redüktörlere aittir. 56 tip elektrik motorlu redüktörler soğutmasız, diğerleri soğutmalıdır.

Dimensions "k1" is for motors with brake. Gearboxes with 56 type electrical motors are not fan cooled, other types are fan cooled.

Maße "k1" sind für Bremsenmotoren. Getriebe mit 56 Motortypen sind ohne Kühlung, andere Typen sind mit Ventilator gekühlt.

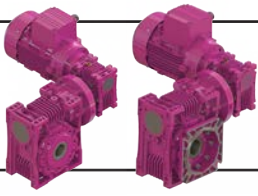

# Ölçü Sayfaları

## Dimension Pages

### Abmessungsseiten



-Mil ucu çekirme deliği DIN 332 sayfa 2 / Tapped center hole to DIN 332, sheet 2 / Zentrierung mit Gewinde DIN 332, Blatt 2

EV040.□ - 030

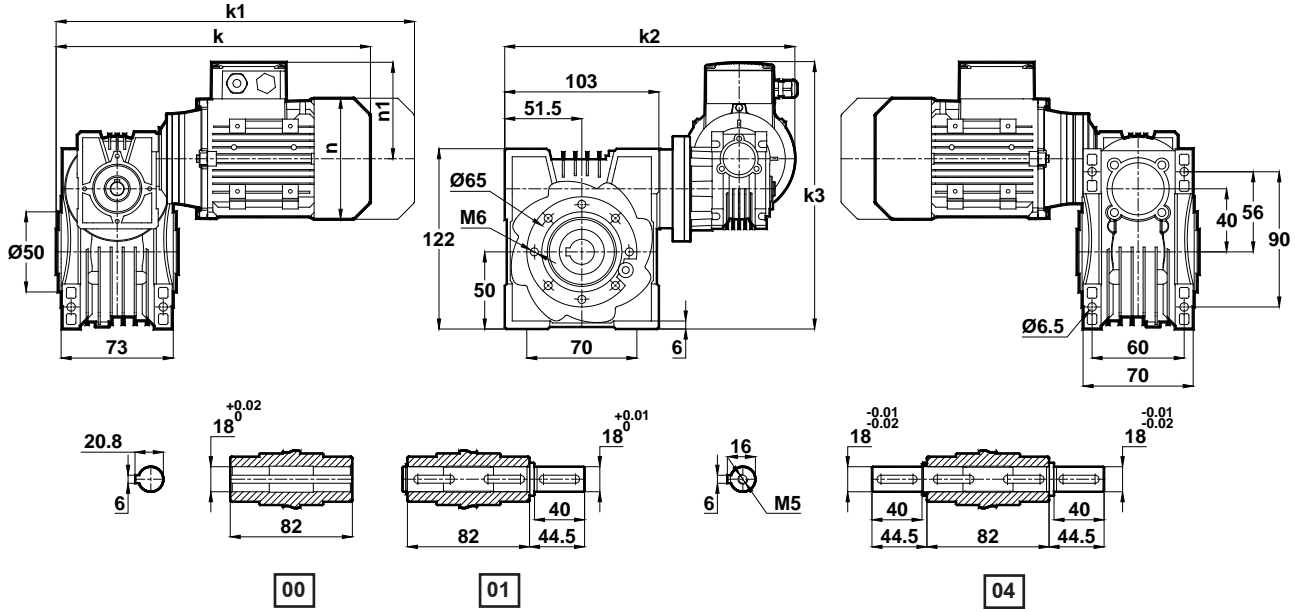

IEC B14	k	k1	k2	k3	n	n1
56	247	-	235.5	216	105	96
63	299	352	243.5	217	121	97

EV040.□ - 030

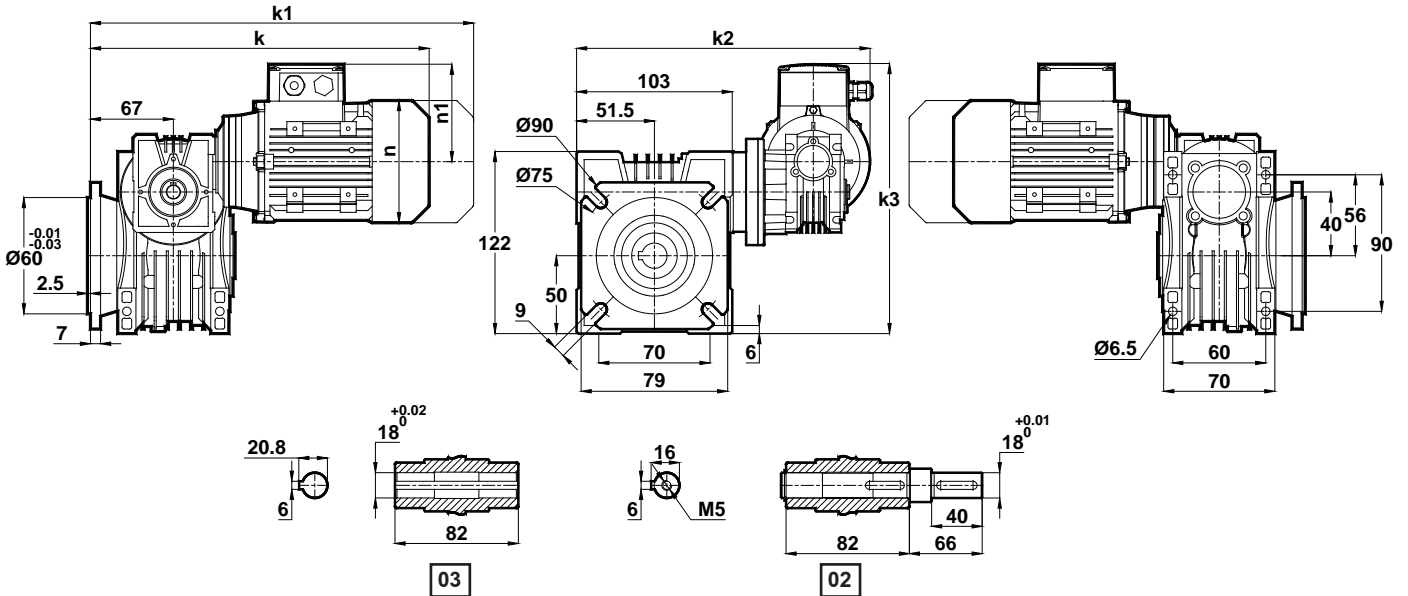

IEC B14	k	k1	k2	k3	n	n1
56	261.5	-	235.5	216	105	96
63	313.5	366.5	243.5	217	121	97

Motorlar B14 flanş ile bağlanmıştır. / Motor connections are with IEC B14 Flange / Motor Befestigung mit IEC B14 Flansch.

"k1" Ölçüsü frenli redüktörlere aittir. 56 tip elektrik motorlu redüktörler soğutmasız, diğerleri soğutmalıdır.

Dimensions "k1" is for motors with brake. Gearboxes with 56 type electrical motors are not fan cooled, other types are fan cooled.

Maße "k1" ist für Bremsenmotoren. Getriebe mit 56 Motortypen sind ohne Kühlung, andere Typen sind mit Ventilator gekühlt.

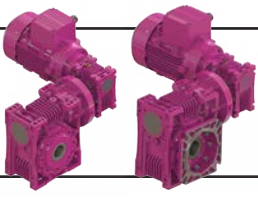

# Ölçü Sayfaları

## Dimension Pages

### Abmessungsseiten

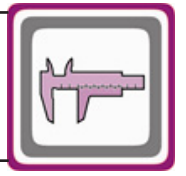

-Mil ucu çektirme deliği DIN 332 sayfa 2 / Tapped center hole to DIN 332, sheet 2 / Zentrierung mit Gewinde DIN 332, Blatt 2

EV050.□ - 030

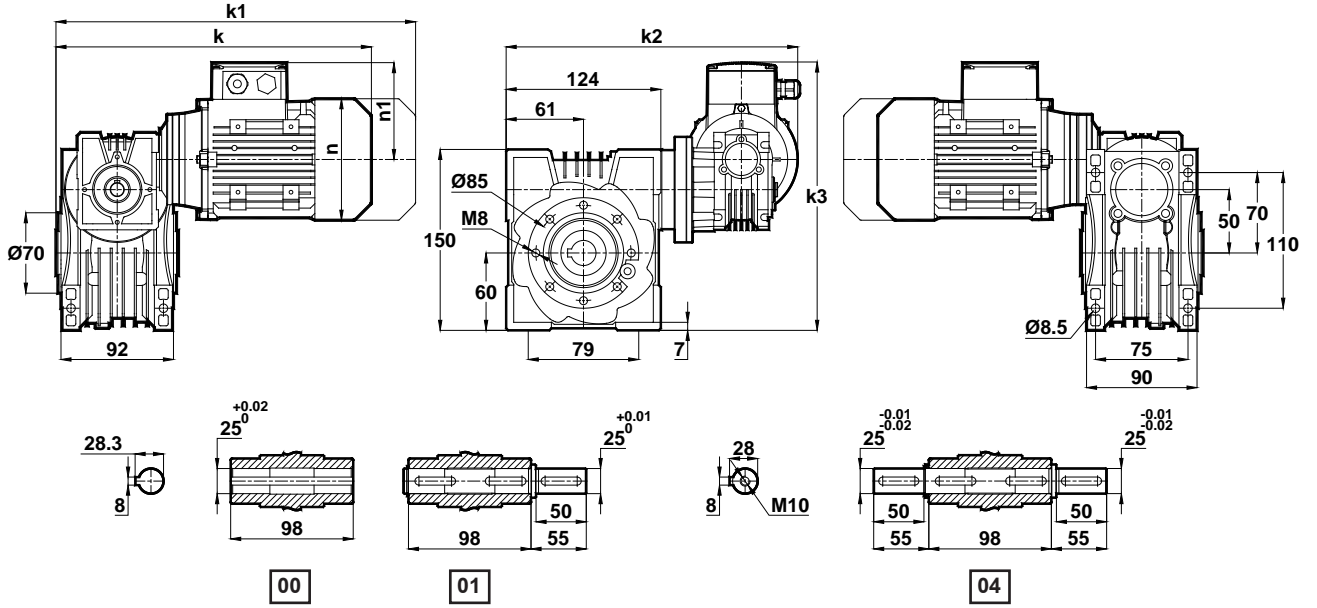

IEC B14	k	k1	k2	k3	n	n1
56	247	-	256.5	236	105	96
63	299	352	264.5	237	121	97

EV050.□ - 030

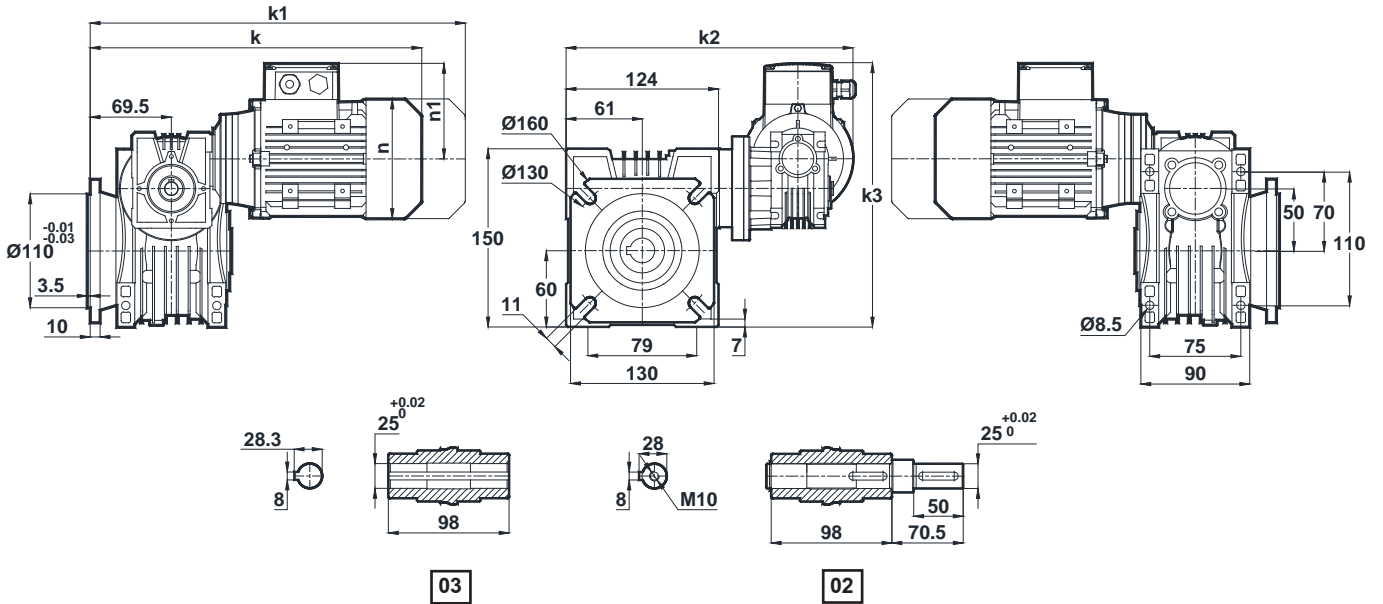

IEC B14	k	k1	k2	k3	n	n1
56	265.5	-	256.5	236	105	96
63	317.5	370.5	264.5	237	121	97

Motorlar B14 flanş ile bağlanmıştır. / Motor connections are with IEC B14 Flange / Motor Befestigung mit IEC B14 Flansch.  
 "k1" Ölçüsü frenli redüktörlere aittir. 56 tip elektrik motorlu redüktörler soğutmasız, diğerleri soğutmalıdır.  
 Dimensions "k1" is for motors with brake. Gearboxes with 56 type electrical motors are not fan cooled, other types are fan cooled.  
 Maße "k1" ist für Bremsenmotoren. Getriebe mit 56 Motortypen sind ohne Kühlung, andere Typen sind mit Ventilator gekühlt.

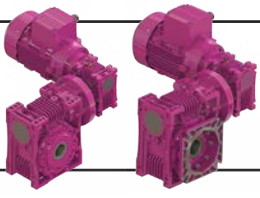

# Ölçü Sayfaları

## Dimension Pages

### Abmessungsseiten



-Mil ucu çektirme deliği DIN 332 sayfa 2 / Tapped center hole to DIN 332, sheet 2 / Zentrierung mit Gewinde DIN 332, Blatt 2

EV063.□ - 030

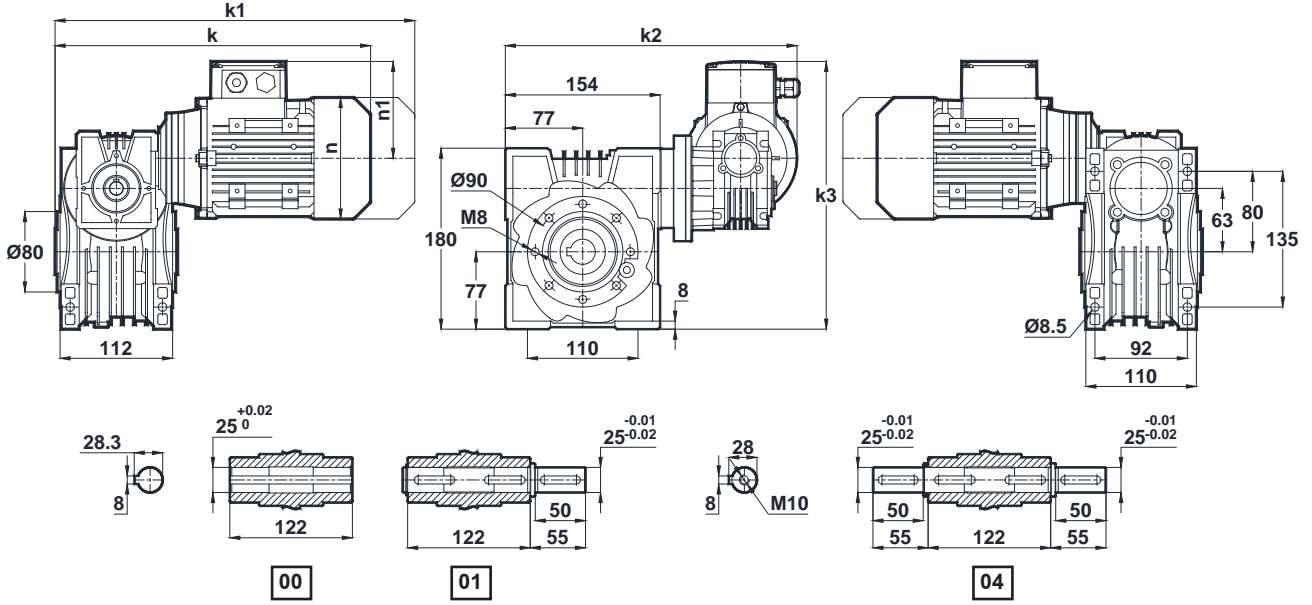

IEC B14	k	k1	k2	k3	n	n1
56	255.5	-	286.5	266	105	96
63	307.5	360.5	294.5	267	121	97

EV063.□ - 030

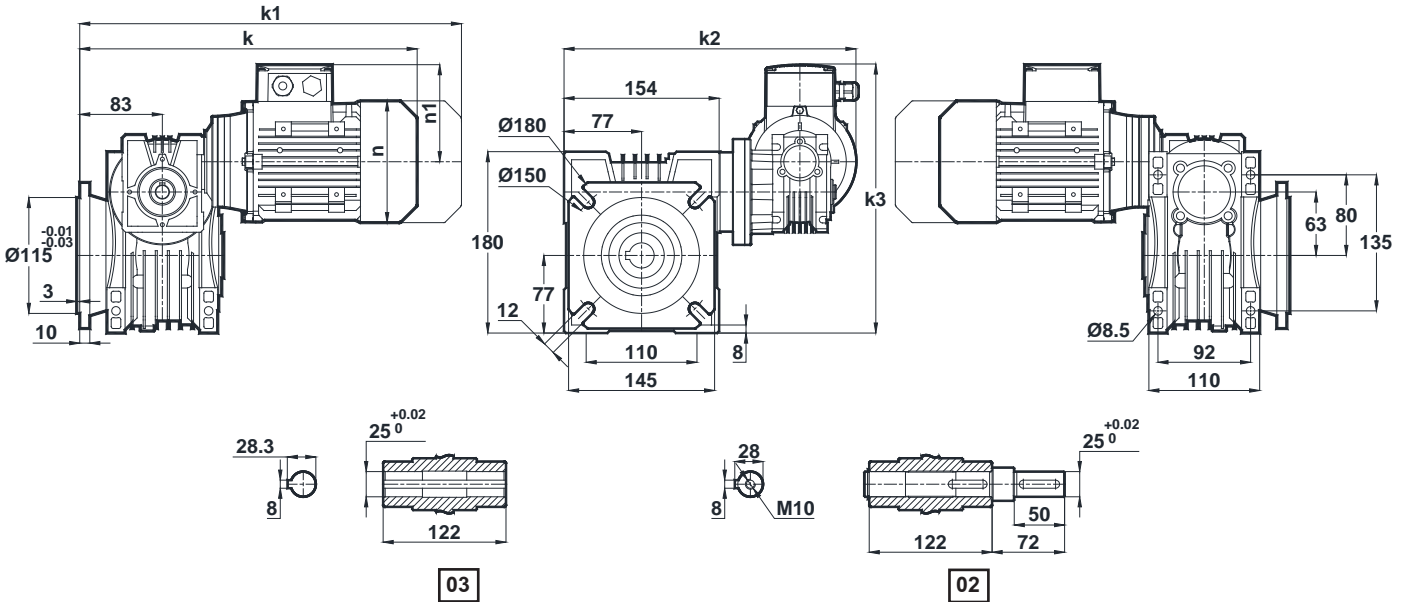

IEC B14	k	k1	k2	k3	n	n1
56	277.5	-	286.5	266	105	96
63	329.5	382.5	294.5	267	121	97

Motorlar B14 flanş ile bağlanmıştır. / Motor connections are with IEC B14 Flange / Motor Befestigung mit IEC B14 Flansch.

"k1" Ölçüsü frenli redüktörlere aittir. 56 tip elektrik motorlu redüktörler soğutmasız, diğerleri soğutmalıdır.

Dimensions "k1" is for motors with brake. Gearboxes with 56 type electrical motors are not fan cooled, other types are fan cooled.

Maße "k1" ist für Bremsenmotoren. Getrieben mit 56 Motortypen sind ohne Kühlung, andere Typen sind mit Ventilator gekühlt.

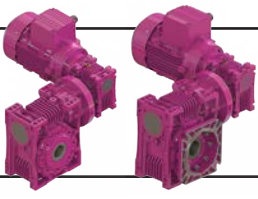

# Ölçü Sayfaları

## Dimension Pages

### Abmessungsseiten

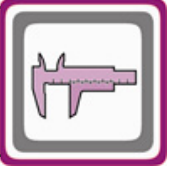

-Mil ucu çektirme deliği DIN 332 sayfa 2 / Tapped center hole to DIN 332, sheet 2 / Zentrierung mit Gewinde DIN 332, Blatt 2

EV075.□ - 040

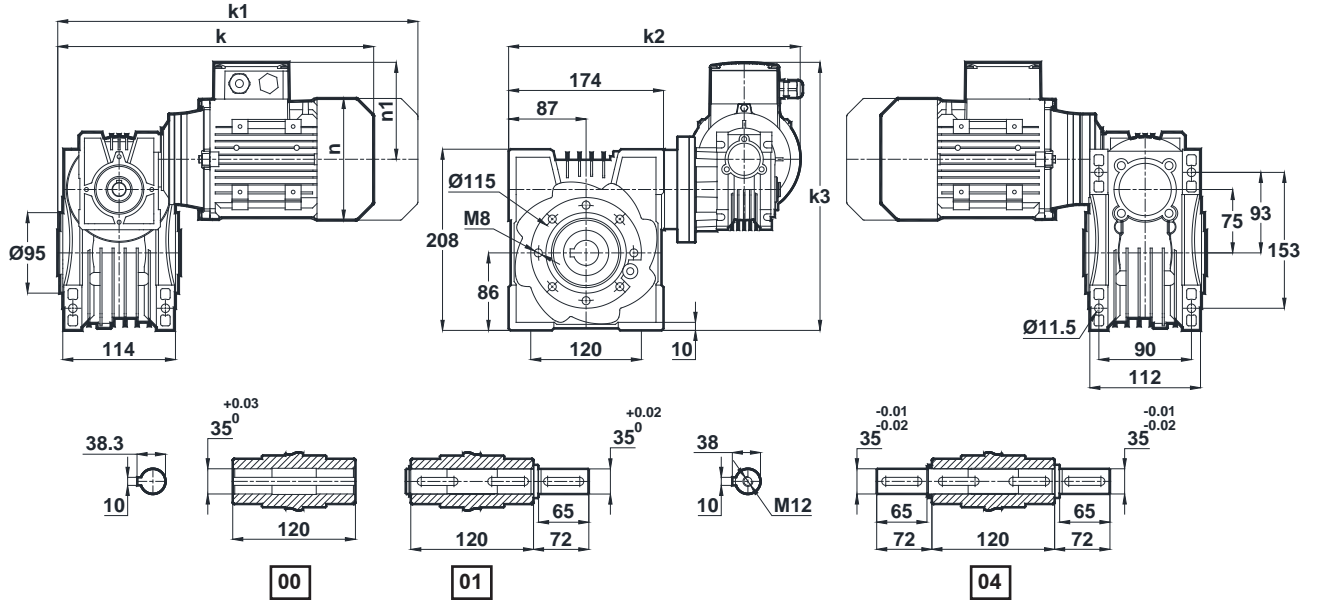

IEC B14	k	k1	k2	k3	n	n1
63	339.5	392.5	333.5	298	121	97
71	347.5	438.5	341.5	313	137	112

EV075.□ - 040

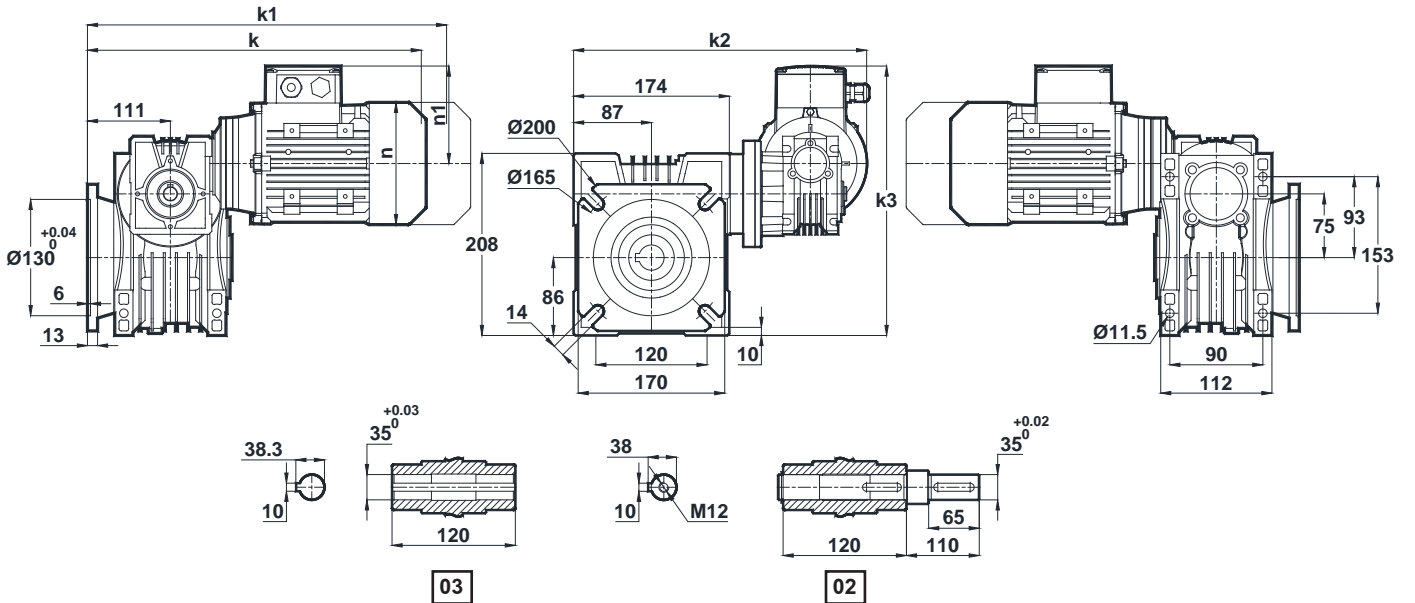

IEC B14	k	k1	k2	k3	n	n1
63	380.5	433.5	333.5	298	121	97
71	398.5	489.5	341.5	313	137	112

Motorlar B14 flanş ile bağlanmıştır. / Motor connections are with IEC B14 Flange / Motor Befestigung mit IEC B14 Flansch.  
 "k1" Ölçüsü frenli redüktörlere aittir. 56 tip elektrik motorlu redüktörler soğutmasız, diğerleri soğutmalıdır.  
 Dimensions "k1" is for motors with brake. Gearboxes with 56 type electrical motors are not fan cooled, other types are fan cooled.  
 Maße "k1" ist für Bremsenmotoren. Getrieben mit 56 Motortypen sind ohne Kühlung, andere Typen sind mit Ventilator gekühlt.

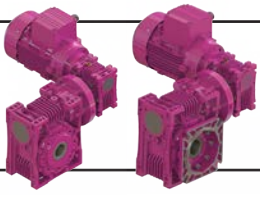

# Ölçü Sayfaları

## Dimension Pages

### Abmessungsseiten

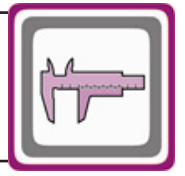

-Mil ucu çektirme deliği DIN 332 sayfa 2 / Tapped center hole to DIN 332, sheet 2 / Zentrierung mit Gewinde DIN 332, Blatt 2

EV080.□ - 040

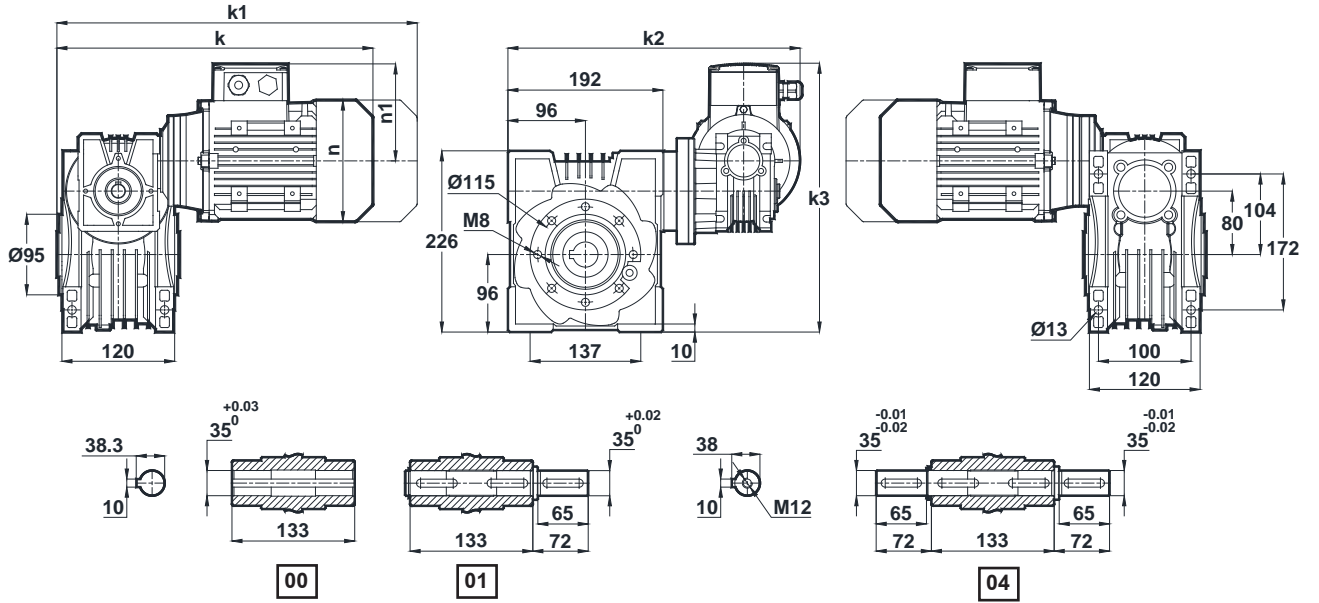

IEC B14	k	k1	k2	k3	n	n1
63	339.5	392.5	333.5	298	121	97
71	354	445	341.5	313	137	112

EV080.□ - 040

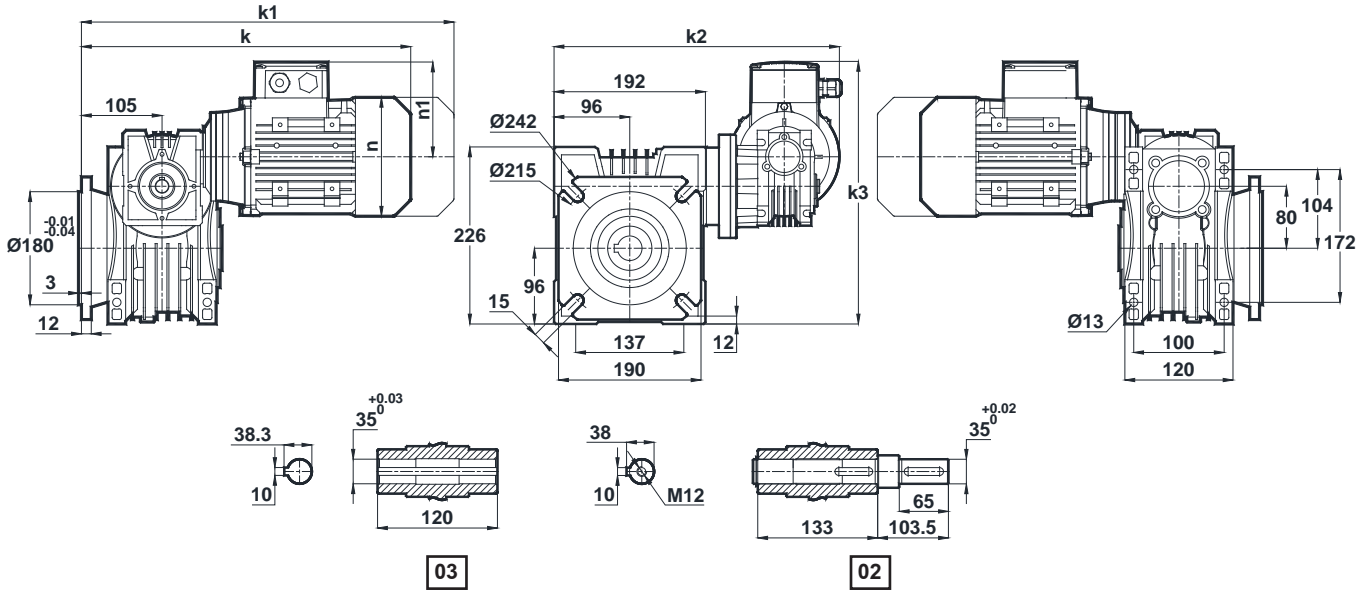

IEC B14	k	k1	k2	k3	n	n1
63	374.5	427.5	351.5	313	121	97
71	392.5	483.5	341.5	313	137	112

Motorlar B14 flanş ile bağlanmıştır. / Motor connections are with IEC B14 Flange / Motor Befestigung mit IEC B14 Flansch.  
 "k1" Ölçüsü frenli redüktörlere aittir. 56 tip elektrik motorlu redüktörler soğutmasız, diğerleri soğutmalıdır.  
 Dimensions "k1" is for motors with brake. Gearboxes with 56 type electrical motors are not fan cooled, other types are fan cooled.  
 Maße "k1" ist für Bremsenmotoren. Getrieben mit 56 Motortypen sind ohne Kühlung, andere Typen sind mit Ventilator gekühlt.



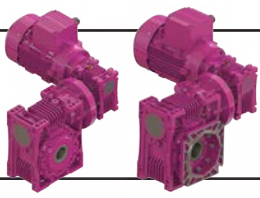

# Ölçü Sayfaları

## Dimension Pages

### Abmessungsseiten



-Mil ucu çekirtilme deliği DIN 332 sayfa 2 / Tapped center hole to DIN 332, sheet 2 / Zentrierung mit Gewinde DIN 332, Blatt 2

EV100.□ - 050

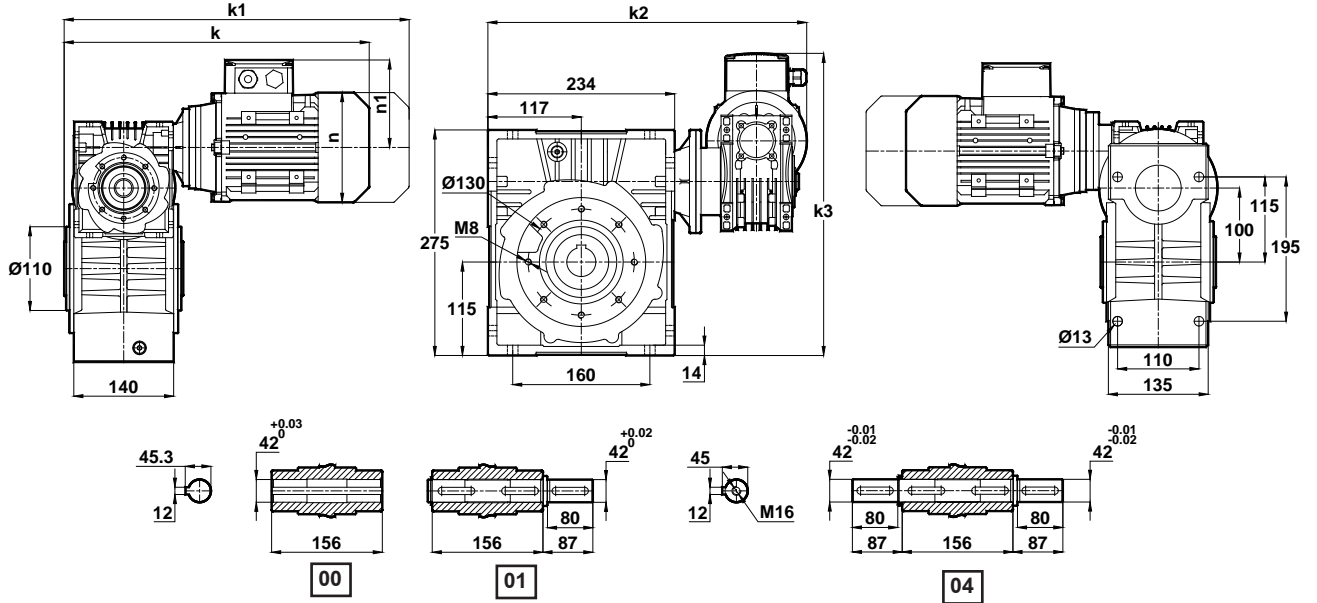

IEC B14	k	k1	k2	k3	n	n1
63	361	414	390.5	362	121	97
71	375.7	466.7	398.5	377	137	112
80	398.7	491.7	407.5	386	155	121
90S	439.7	544.2	418	397	176	132
90L	439.7	544.2	418	397	176	132

EV100.□ - 050

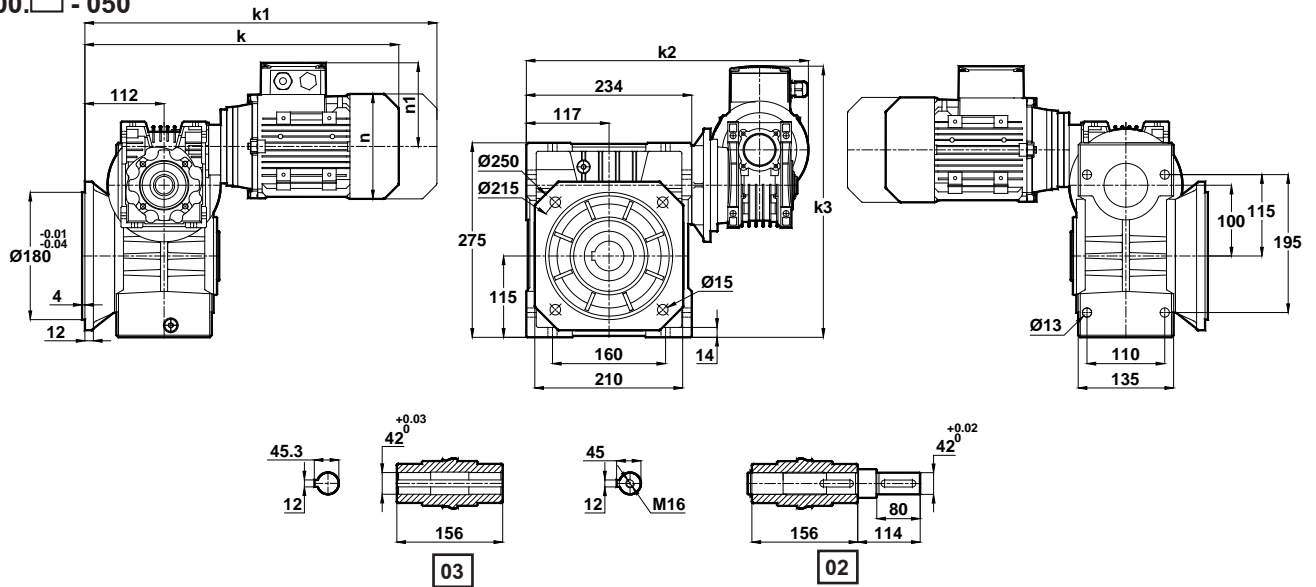

IEC B14	k	k1	k2	k3	n	n1
63	393	446	390.5	362	121	97
71	409.7	500.7	398.5	377	137	112
80	432.7	525.7	407.5	386	155	121
90S	473.7	578.2	418	397	176	133
90L	473.7	578.2	418	397	176	133

Motorlar B14 flanş ile bağlanmıştır. / Motor connections are with IEC B14 Flange / Motor Befestigung mit IEC B14 Flansch.  
"k1" Ölçüsü frenli redüktörlere aittir. 56 tip elektrik motorlu redüktörler soğutmasız, diğerleri soğutmalıdır.  
Dimensions "k1" is for motors with brake. Gearboxes with 56 type electrical motors are not fan cooled, other types are fan cooled.  
Maße "k1" ist für Bremsenmotoren. Getrieben mit 56 Motortypen sind ohne Kühlung, andere Typen sind mit Ventilator gekühlt.

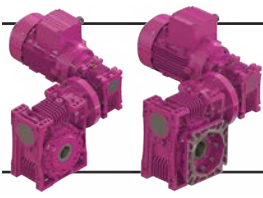

# Ölçü Sayfaları

## Dimension Pages

### Abmessungsseiten

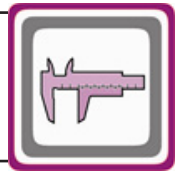

-Mil ucu çektirme deliği DIN 332 sayfa 2 / Tapped center hole to DIN 332, sheet 2 / Zentrierung mit Gewinde DIN 332, Blatt 2

#### EV125.□ - 063

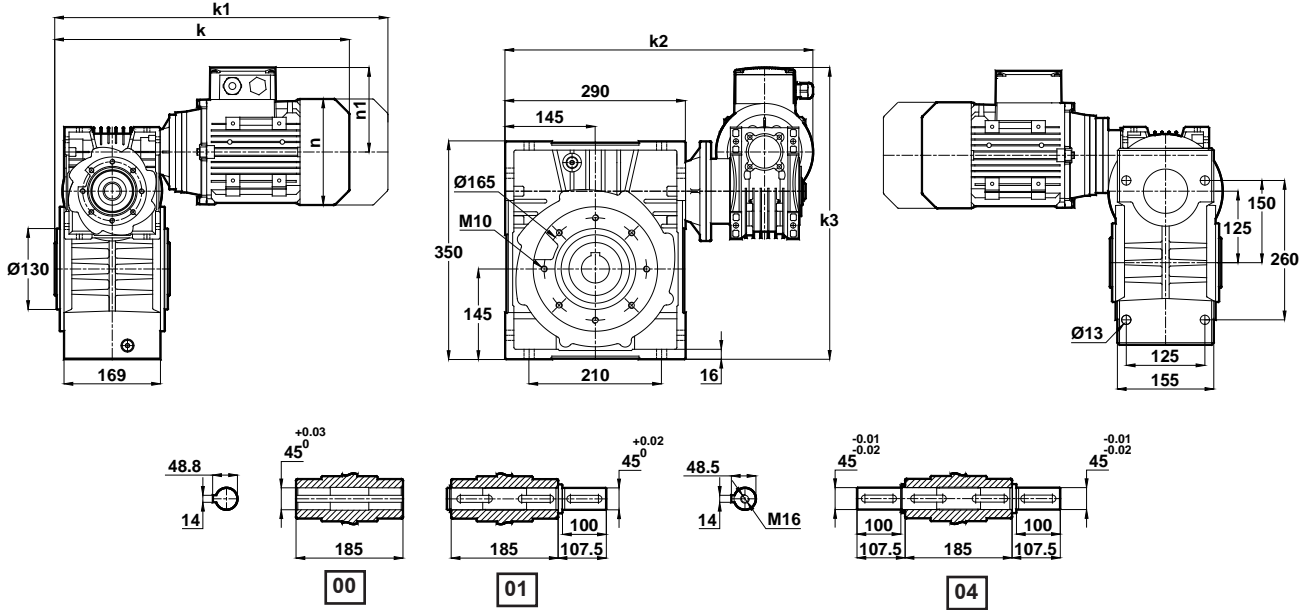

IEC B14	k	k1	k2	k3	n	n1
71	405.2	496.2	485.5	445	137	112
80	428.2	521.2	494.5	454	155	121
90S	469.2	573.7	505	465	176	133
90L	469.2	573.7	505	465	176	133

#### EV125.□ - 063

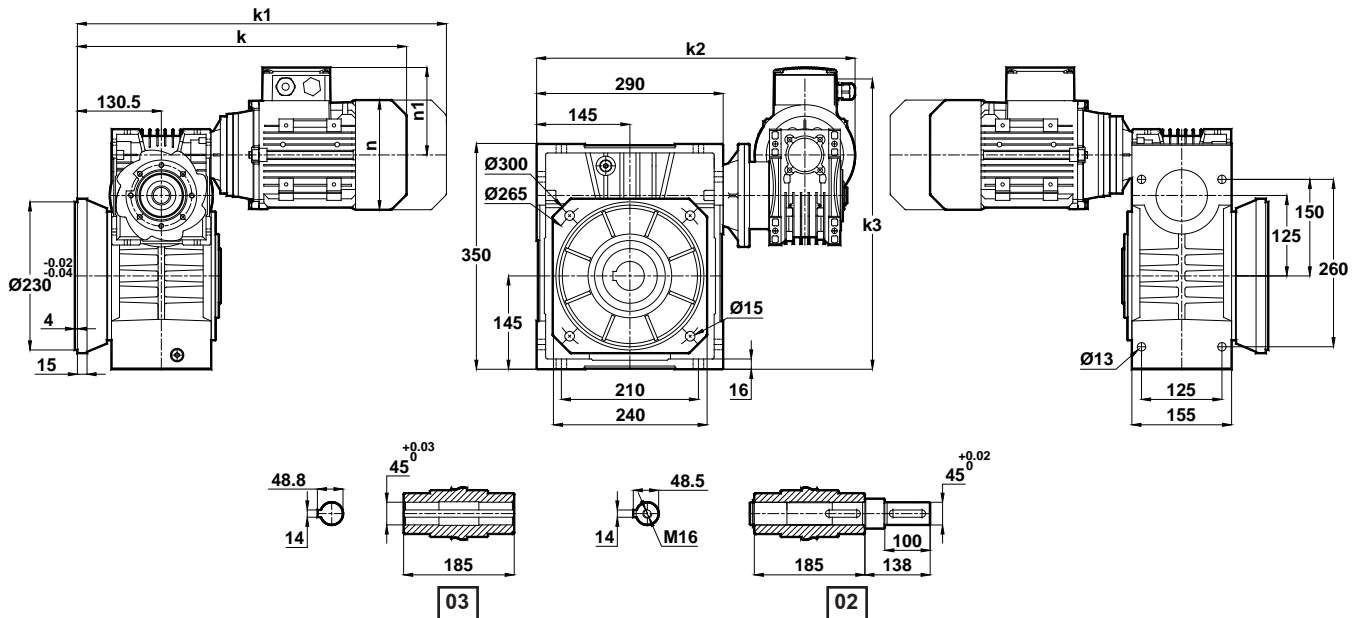

IEC B14	k	k1	k2	k3	n	n1
71	443.2	534.2	485.5	445	137	112
80	466.2	559.2	494.5	454	155	121
90S	507.2	611.7	505	465	176	133
90L	507.2	611.7	505	465	176	133

Motorlar B14 flanş ile bağlanmıştır. / Motor connections are with IEC B14 Flange / Motor Befestigung mit IEC B14 Flansch.  
 "k1" Ölçüsü frenli redüktörlere aittir. 56 tip elektrik motorlu redüktörler soğutmasız, diğerleri soğutmalıdır.  
 Dimensions "k1" is for motors with brake. Gearboxes with 56 type electrical motors are not fan cooled, other types are fan cooled.  
 Maße "k1" ist für Bremsenmotoren. Getrieben mit 56 Motortypen sind ohne Kühlung, andere Typen sind mit Ventilator gekühlt.

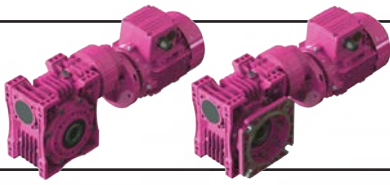

# Ölçü Sayfaları Dimension Pages Abmessungsseiten

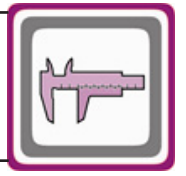

-Mil ucu çekirme deliği DIN 332 sayfa 2 / Tapped center hole to DIN 332, sheet 2 / Zentrierung mit Gewinde DIN 332, Blatt 2

EV050.□ - NR01

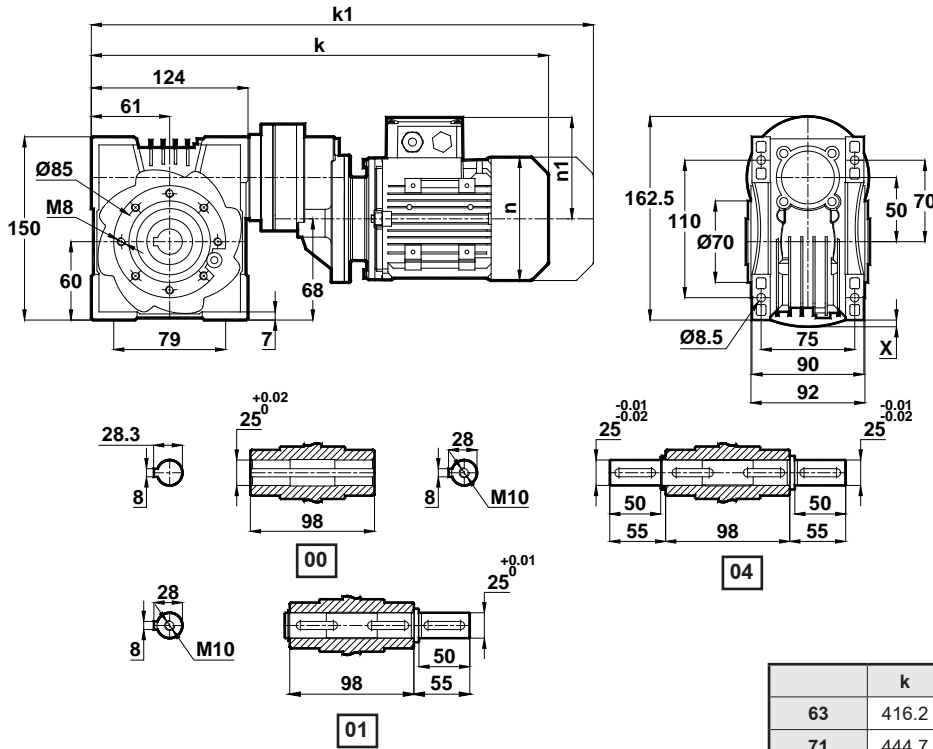

Klemens Pozisyonları  
Terminal Box Positions / Klemmenkasten

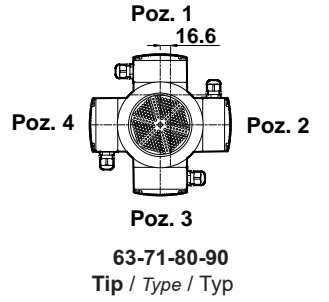

EV050.□ - NR01

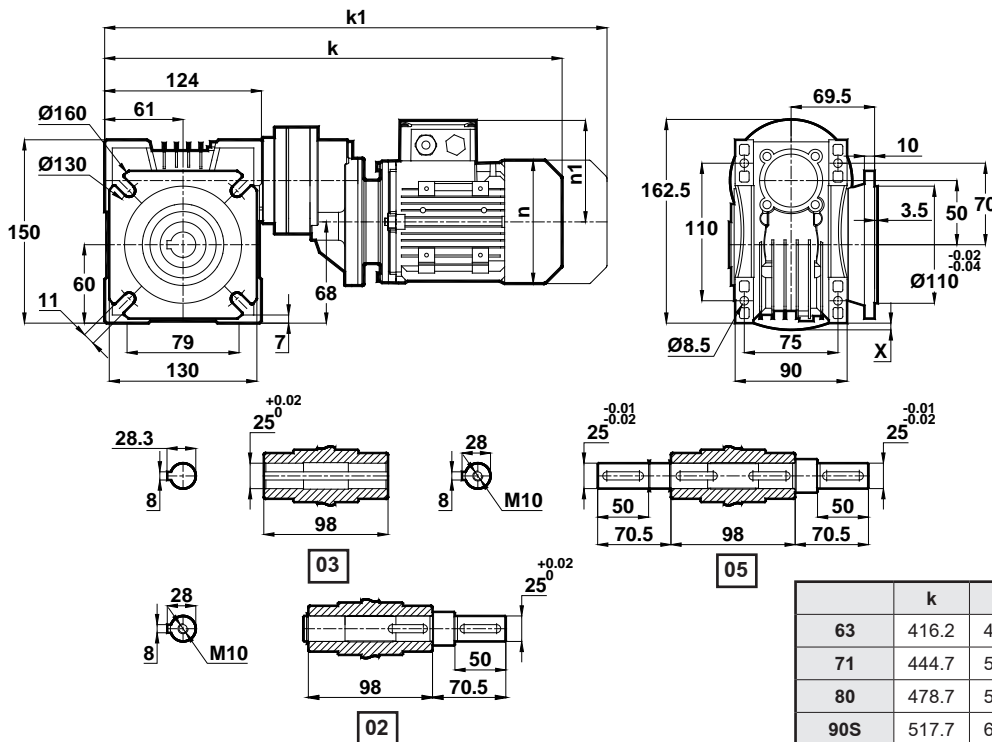

Klemens Pozisyonları  
Terminal Box Positions / Klemmenkasten

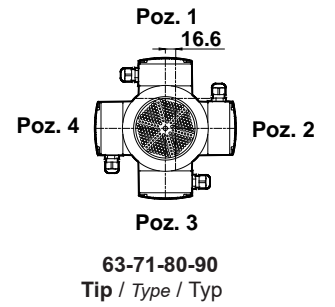

"k1" Ölçüsü frenli redüktörlere aittir. 56 tip elektrik motorlu redüktörler soğutmasız, diğerleri soğutmalıdır.  
Dimensions "k1" is for motors with brake. Gearboxes with 56 type electrical motors are not fan cooled, other types are fan cooled.  
Maße "k1" ist für Bremsenmotoren. Getrieben mit 56 Motortypen sind ohne Kühlung, andere Typen sind mit Ventilator gekühlt.

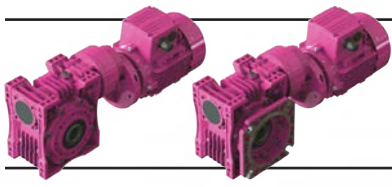

# Ölçü Sayfaları Dimension Pages Abmessungenseiten



-Mil ucu çekirme deliği DIN 332 sayfa 2 / Tapped center hole to DIN 332, sheet 2 / Zentrierung mit Gewinde DIN 332, Blatt 2

EV063.□ - NR01

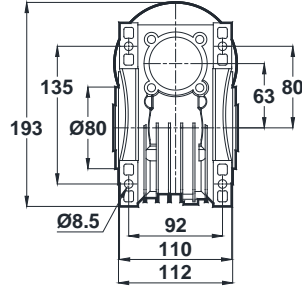
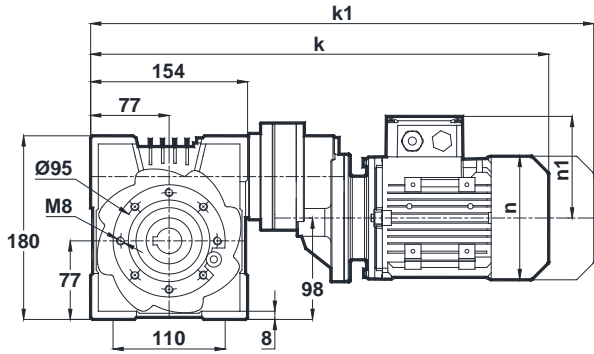

Klemens Pozisyonları  
Terminal Box Positions / Klemmenkasten

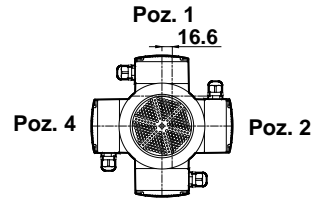

Poz. 1  
16.6  
Poz. 2  
Poz. 3  
63-71-80-90  
Tip / Type / Typ

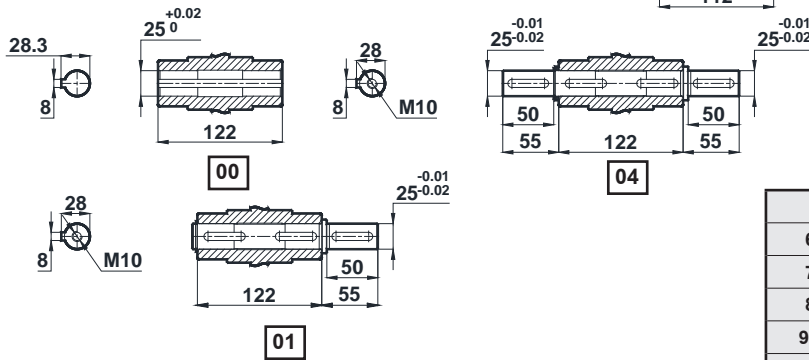

	k	k1	n	n1
63	446.2	507.2	121	97
71	474.7	565.7	137	112
80	508.7	601.7	155	121
90S	547.7	651.2	176	133
90L	547.7	651.2	176	133

EV063.□ - NR01

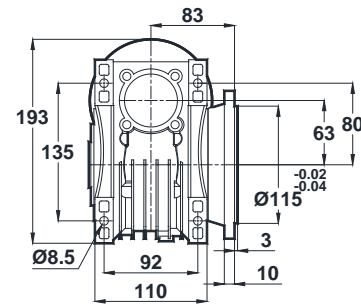
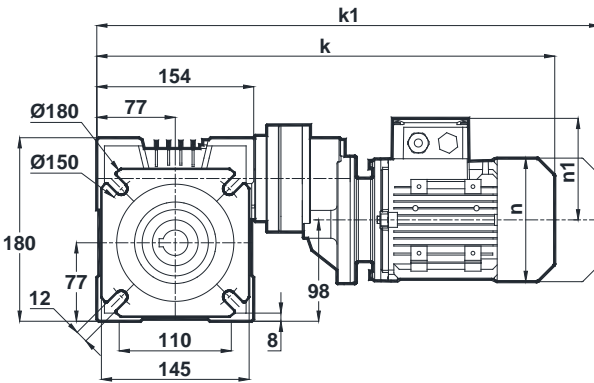

Klemens Pozisyonları  
Terminal Box Positions / Klemmenkasten

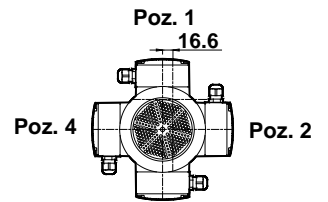

Poz. 1  
16.6  
Poz. 2  
Poz. 3  
63-71-80-90  
Tip / Type / Typ

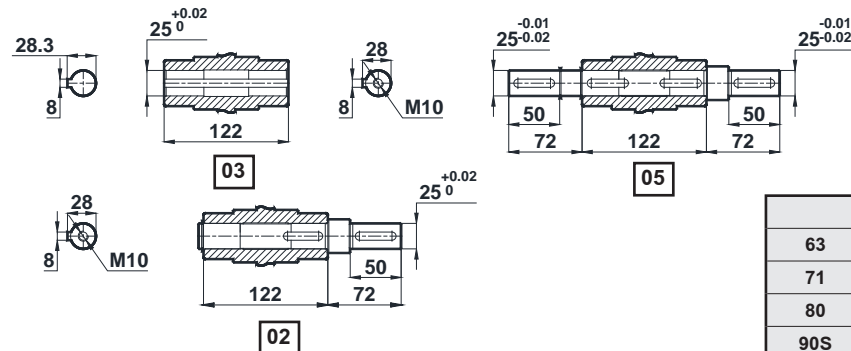

	k	k1	n	n1
63	446.2	507.2	121	97
71	474.7	565.7	137	112
80	508.7	601.7	155	121
90S	547.7	651.2	176	133
90L	547.7	651.2	176	133

"k1" Ölçüsü frenli redüktörlere aittir. 56 tip elektrik motorlu redüktörler soğutmasız, diğerleri soğutmalıdır.  
Dimensions "k1" is for motors with brake. Gearboxes with 56 type electrical motors are not fan cooled, other types are fan cooled.  
Maße "k1" ist für Bremsenmotoren. Getrieben mit 56 Motortypen sind ohne Kühlung, andere Typen sind mit Ventilator gekühlt.

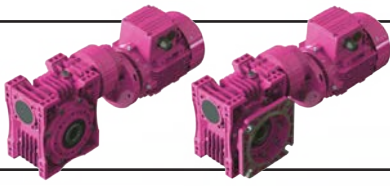

# Ölçü Sayfaları Dimension Pages Abmessungsseiten



-Mil ucu çektirme deliği DIN 332 sayfa 2 / Tapped center hole to DIN 332, sheet 2 / Zentrierung mit Gewinde DIN 332, Blatt 2

EV075.□ - NR11

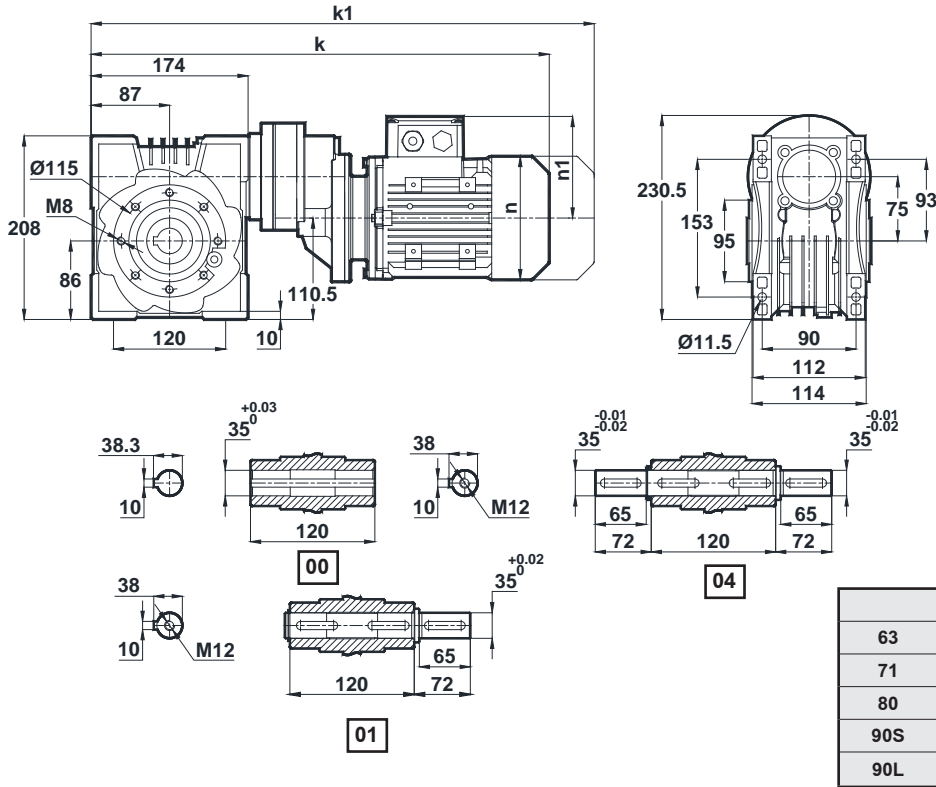

Klemens Pozisyonları  
Terminal Box Positions / Klemmenkasten

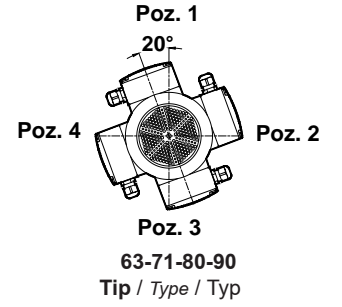

	k	k1	n	n1
63	464	525	121	97
71	492.5	583.5	137	112
80	526.5	619.5	155	121
90S	565.5	669	176	133
90L	565.5	669	176	133

EV075.□ - NR11

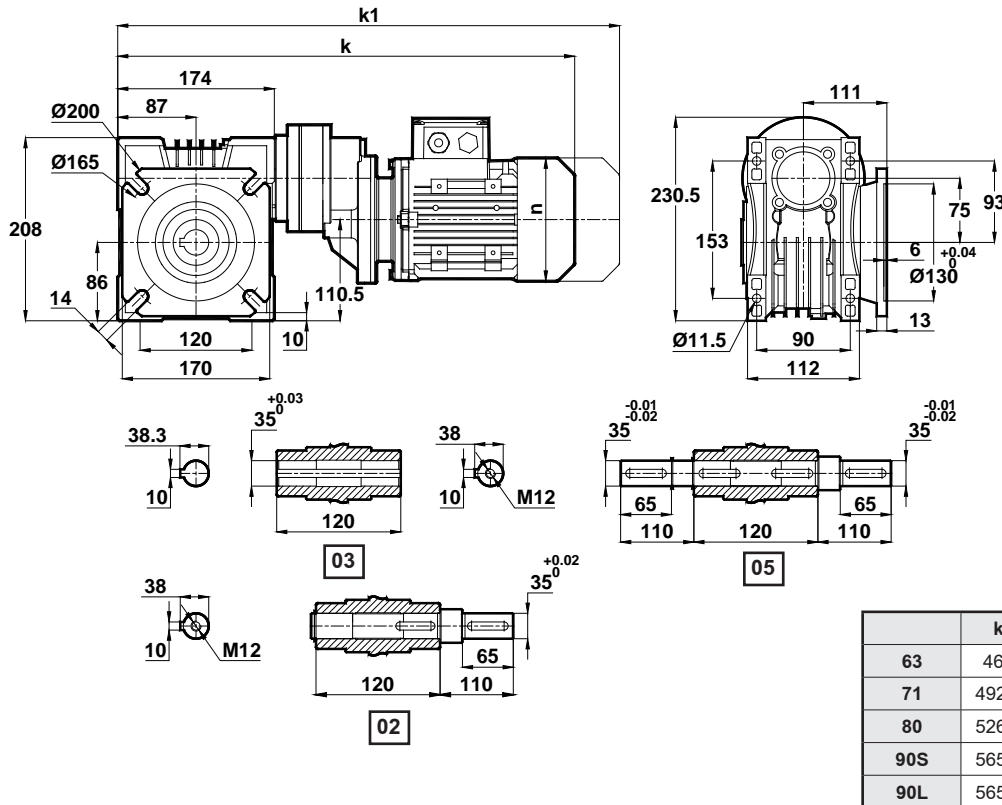

Klemens Pozisyonları  
Terminal Box Positions / Klemmenkasten

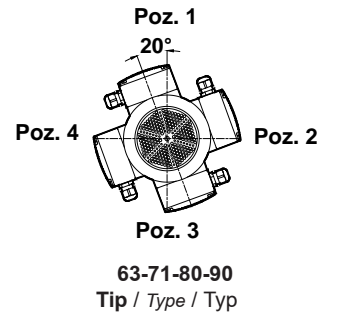

	k	k1	n	n1
63	464	525	121	97
71	492.5	583.5	137	112
80	526.5	619.5	155	121
90S	565.5	669	176	133
90L	565.5	669	176	133

"k1" Ölçüsü frenli redüktörlere aittir. 56 tip elektrik motorlu redüktörler soğutmasız, diğerleri soğutmalıdır.  
Dimensions "k1" is for motors with brake. Gearboxes with 56 type electrical motors are not fan cooled, other types are fan cooled.  
Maße "k1" ist für Bremsenmotoren. Getrieben mit 56 Motortypen sind ohne Kühlung, andere Typen sind mit Ventilator gekühlt.

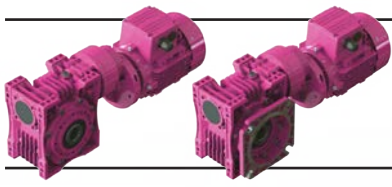

# Ölçü Sayfaları

## Dimension Pages

### Abmessungsseiten



-Mil ucu çektirme deliği DIN 332 sayfa 2 / Tapped center hole to DIN 332, sheet 2 / Zentrierung mit Gewinde DIN 332, Blatt 2

EV080.□ - NR11

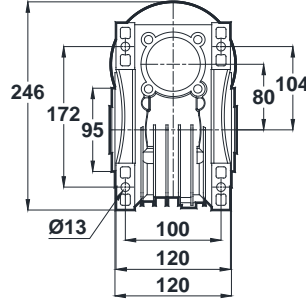
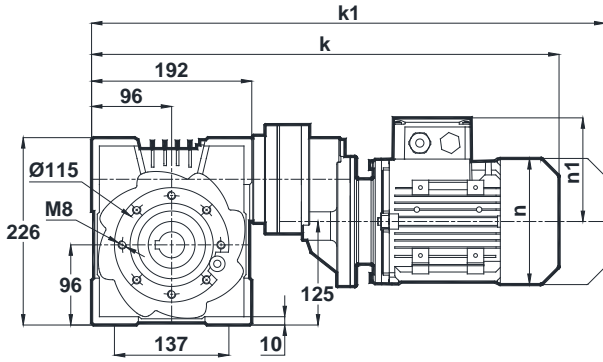

Klemens Pozisyonları  
Terminal Box Positions / Klemmenkasten

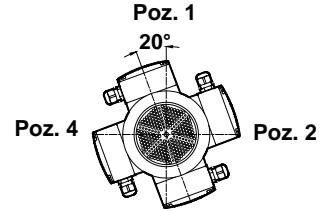

Poz. 1

63-71-80-90  
Tip / Type / Typ

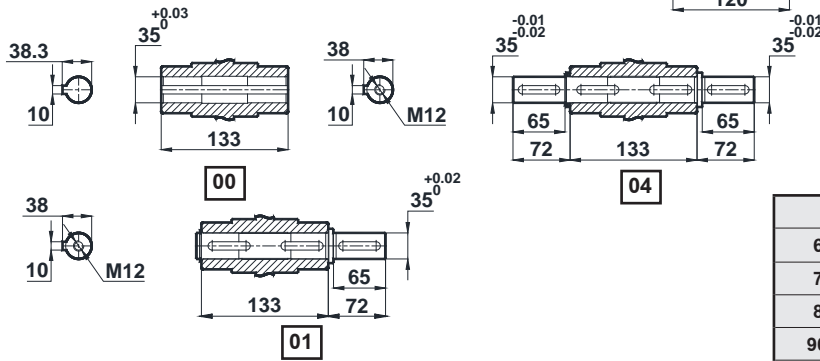

	k	k1	n	n1
63	482	543	121	97
71	510.5	601.5	137	112
80	544.5	637.5	155	121
90S	583.5	687	176	133
90L	583.5	687	176	133

EV080.□ - NR11

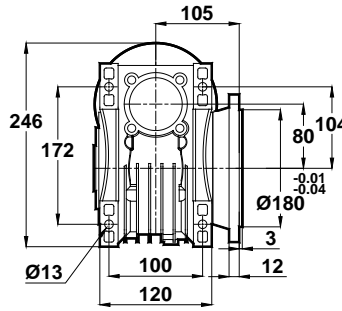
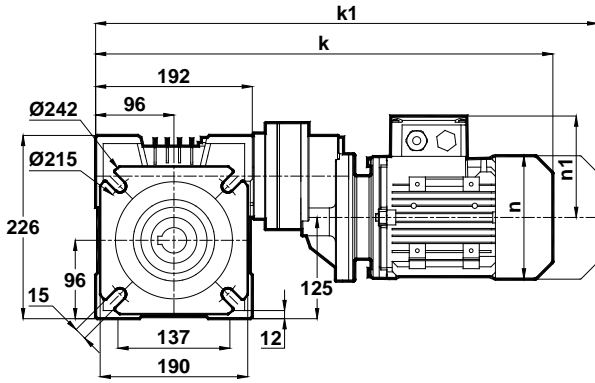

Klemens Pozisyonları  
Terminal Box Positions / Klemmenkasten

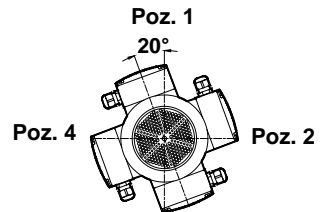

Poz. 1

63-71-80-90  
Tip / Type / Typ

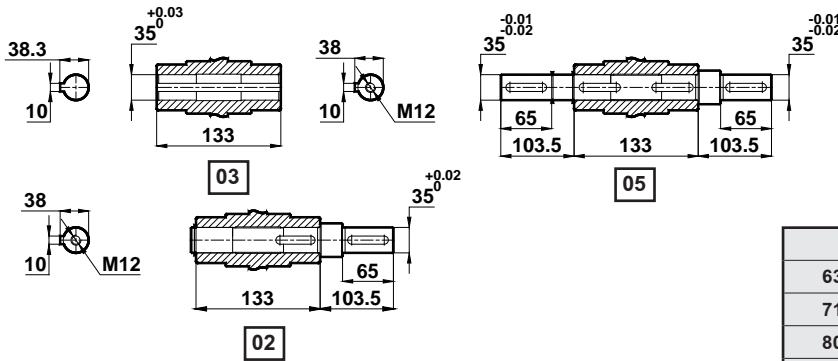

	k	k1	n	n1
63	482	543	121	97
71	510.5	601.5	137	112
80	544.5	637.5	155	121
90S	583.5	687	176	133
90L	583.5	687	176	133

"k1" Ölçüsü frenli redüktörlere aittir. 56 tip elektrik motorlu redüktörler soğutmasız, diğerleri soğutmalıdır.  
Dimensions "k1" is for motors with brake. Gearboxes with 56 type electrical motors are not fan cooled, other types are fan cooled.  
Maße "k1" ist für Bremsenmotoren. Getrieben mit 56 Motortypen sind ohne Kühlung, andere Typen sind mit Ventilator gekühlt.

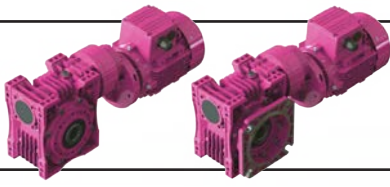

# Ölçü Sayfaları

## Dimension Pages

### Abmessungsseiten



-Mil ucu çekirme deliği DIN 332 sayfa 2 / Tapped center hole to DIN 332, sheet 2 / Zentrierung mit Gewinde DIN 332, Blatt 2

EV100.□ - NR11

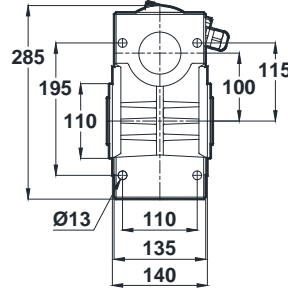
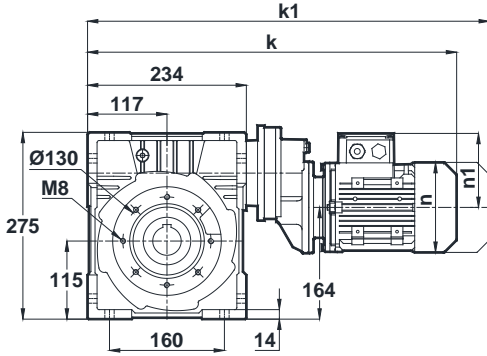

Klemens Pozisyonları  
Terminal Box Positions / Klemmenkasten

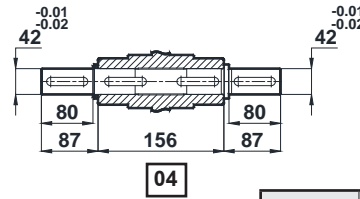
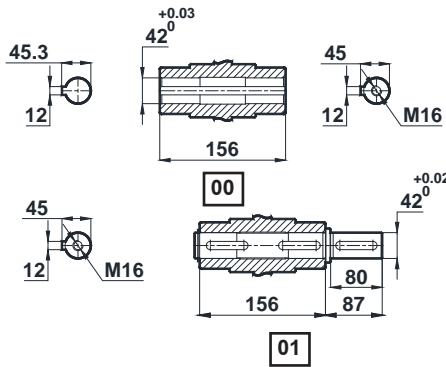
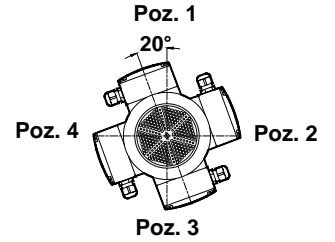

63-71-80-90  
Tip / Type / Typ

	k	k1	n	n1
63	524	585	121	97
71	552.5	643.5	137	112
80	586.5	679.5	155	121
90S	625.5	729	176	133
90L	625.5	729	176	133

EV100.□ - NR11

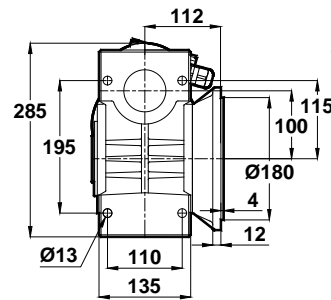
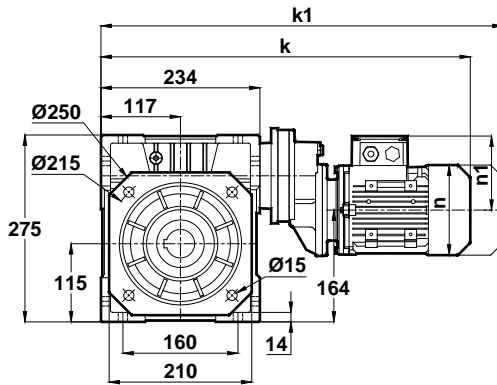

Klemens Pozisyonları  
Terminal Box Positions / Klemmenkasten

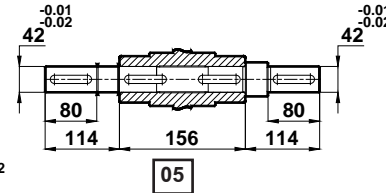
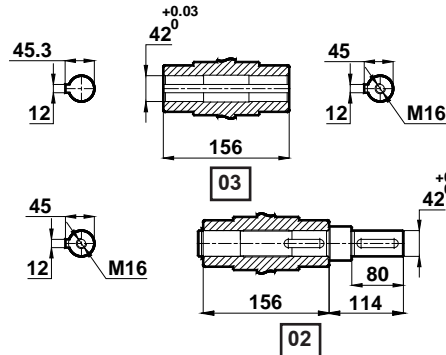
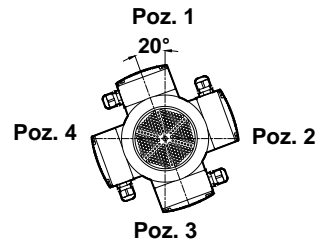

63-71-80-90  
Tip / Type / Typ

	k	k1	n	n1
63	524	585	121	97
71	552.5	643.5	137	112
80	586.5	679.5	155	121
90S	625.5	729	176	133
90L	625.5	729	176	133

"k1" Ölçüsü frenli redüktörlere aittir. 56 tip elektrik motorlu redüktörler soğutmasız, diğerleri soğutmalıdır.  
Dimensions "k1" is for motors with brake. Gearboxes with 56 type electrical motors are not fan cooled, other types are fan cooled.  
Maße "k1" ist für Bremsenmotoren. Getrieben mit 56 Motortypen sind ohne Kühlung, andere Typen sind mit Ventilator gekühlt.

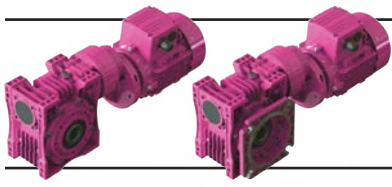

# Ölçü Sayfaları

## Dimension Pages

### Abmessungsseiten

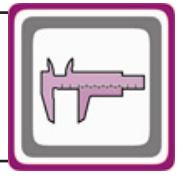

-Mil ucu çekirme deliği DIN 332 sayfa 2 / Tapped center hole to DIN 332, sheet 2 / Zentrierung mit Gewinde DIN 332, Blatt 2

EV125.□ - NR21

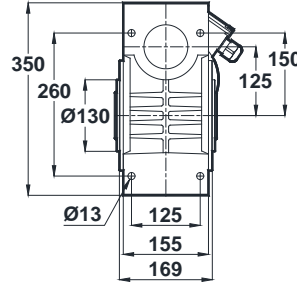
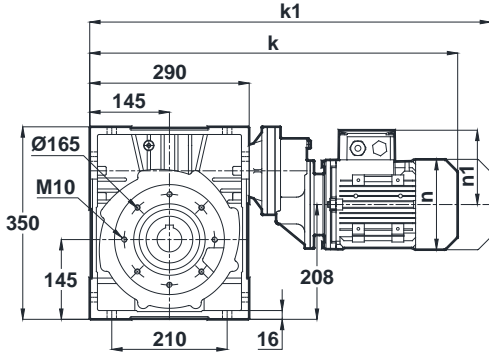

**Klemens Pozisyonları**  
Terminal Box Positions / Klemmenkasten

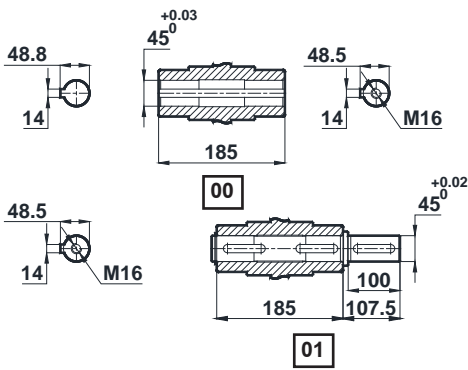
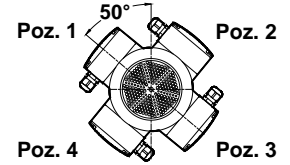

63-71-80-90-100-112  
Tip / Type / Typ

	k	k1	n	n1
63	595	656	121	97
71	622	713	137	112
80	656	749	155	121
90S	695	798.5	176	133
90L	695	798.5	176	133
100L	743	851.5	193	147
112M	767	871.5	215	158

EV125.□ - NR21

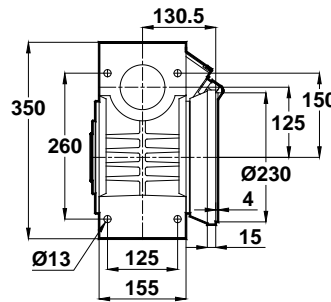
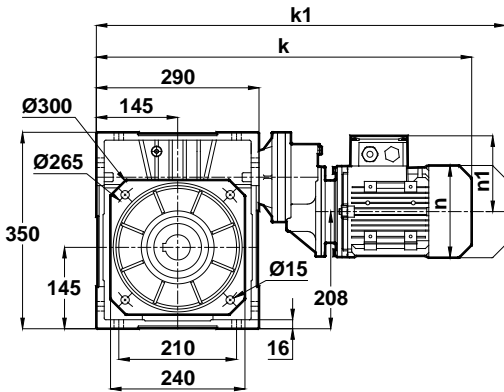

**Klemens Pozisyonları**  
Terminal Box Positions / Klemmenkasten

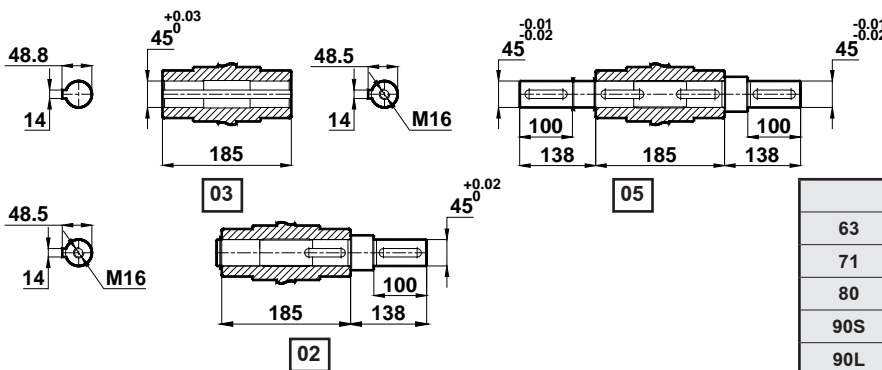
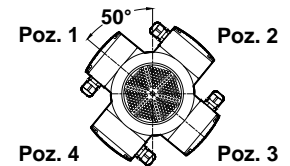

63-71-80-90-100-112  
Tip / Type / Typ

	k	k1	n	n1
63	595	656	121	97
71	622	713	138	112
80	656	749	156	121
90S	695	798.5	176	133
90L	695	798.5	176	133
100L	743	851.5	193	147
112M	767	871.5	215	158

"k1" Ölçüsü frenli redüktörlere aittir. 56 tip elektrik motorlu redüktörler soğutmasız, diğerleri soğutmalıdır.  
Dimensions "k1" is for motors with brake. Gearboxes with 56 type electrical motors are not fan cooled, other types are fan cooled.  
Maße "k1" ist für Bremsenmotoren. Getrieben mit 56 Motortypen sind ohne Kühlung, andere Typen sind mit Ventilator gekühlt.



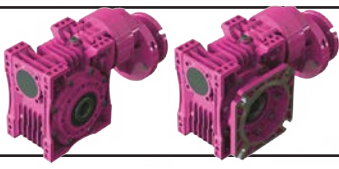

# Ölçü Sayfaları

## Dimension Pages

### Abmessungsseiten



-Mil ucu çekirtme deliği DIN 332 sayfa 2 / Tapped center hole to DIN 332, sheet 2 / Zentrierung mit Gewinde DIN 332, Blatt 2

#### EV050.□ - NN01

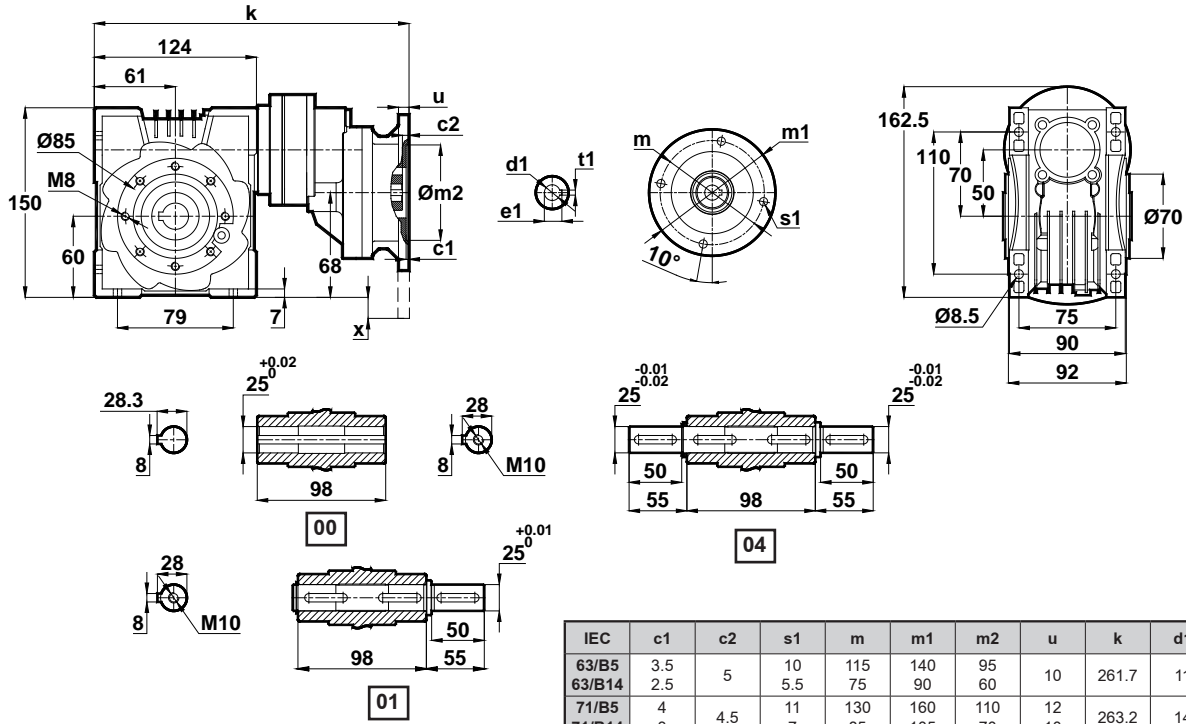

IEC	c1	c2	s1	m	m1	m2	u	k	d1	t1	e1	x
63/B5	3.5		10	115	140	95	10	261.7	11	4	12.8	2
63/B14	2.5	5	5.5	75	90	60	10	261.7	11	4	12.8	-
71/B5	4		11	130	160	110	12	263.2	14	5	16.3	12
71/B14	3	4.5	7	85	105	70	10	263.2	14	5	16.3	-
80/B5	4	5	12	165	200	130	12	278.2	19	6	21.8	32
80/B14	4	5	7	100	120	80	12	278.2	19	6	21.8	-
90/B5	4	5	12	165	200	130	12	278.2	24	8	27.3	32
90/B14	4	5	9	115	140	95	12	278.2	24	8	27.3	-

#### EV050.□ - NN01

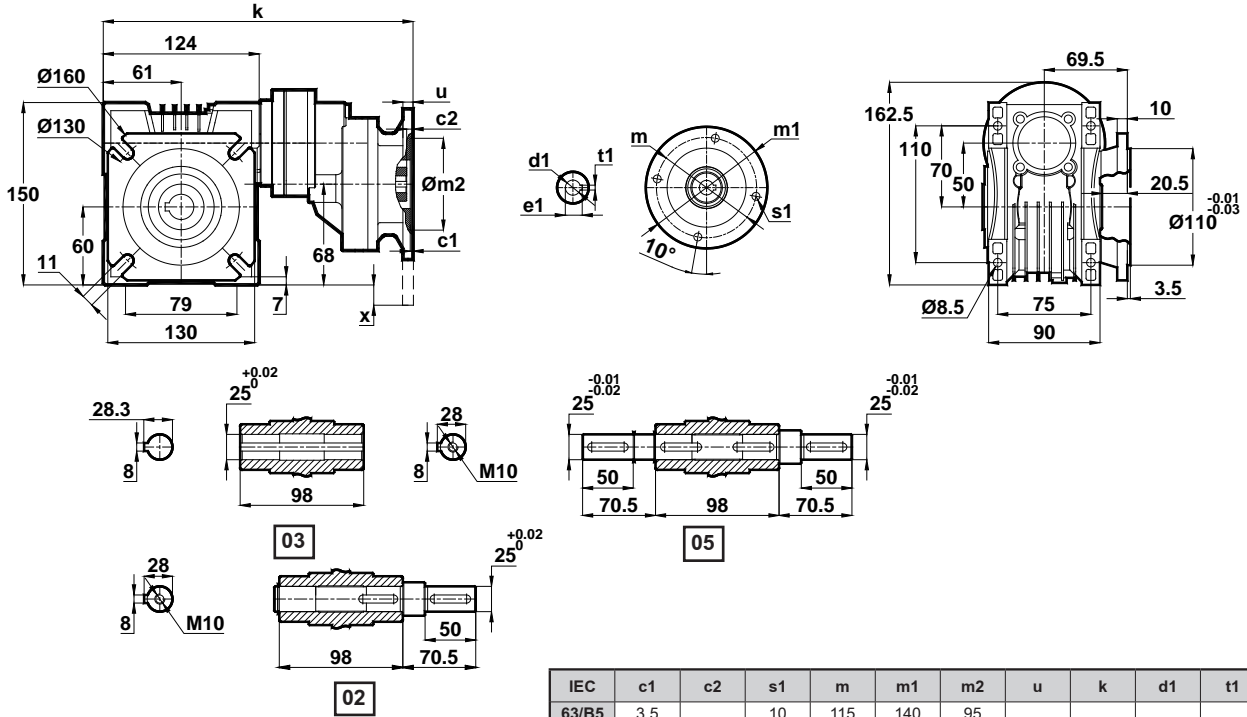

IEC	c1	c2	s1	m	m1	m2	u	k	d1	t1	e1	x
63/B5	3.5		10	115	140	95	10	261.7	11	4	12.8	2
63/B14	2.5	5	5.5	75	90	60	10	261.7	11	4	12.8	-
71/B5	4		11	130	160	110	12	263.2	14	5	16.3	12
71/B14	3	4.5	7	85	105	70	10	263.2	14	5	16.3	-
80/B5	4	5	12	165	200	130	12	278.2	19	6	21.8	32
80/B14	4	5	7	100	120	80	12	278.2	19	6	21.8	-
90/B5	4	5	12	165	200	130	12	278.2	24	8	27.3	32
90/B14	4	5	9	115	140	95	12	278.2	24	8	27.3	-

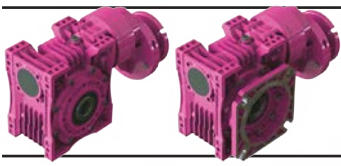

# Ölçü Sayfaları

## Dimension Pages

### Abmessungsseiten

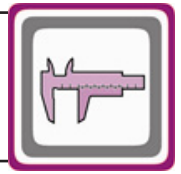

-Mil ucu çekirme deliği DIN 332 sayfa 2 / Tapped center hole to DIN 332, sheet 2 / Zentrierung mit Gewinde DIN 332, Blatt 2

EV063.□ - NN01

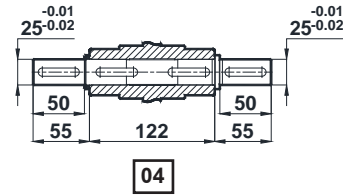
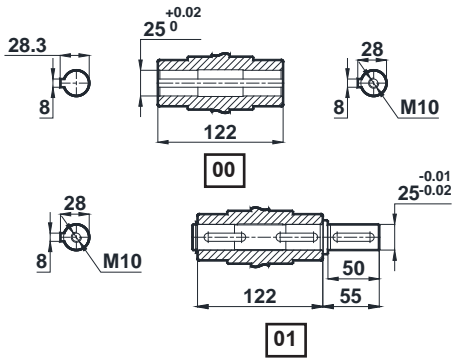
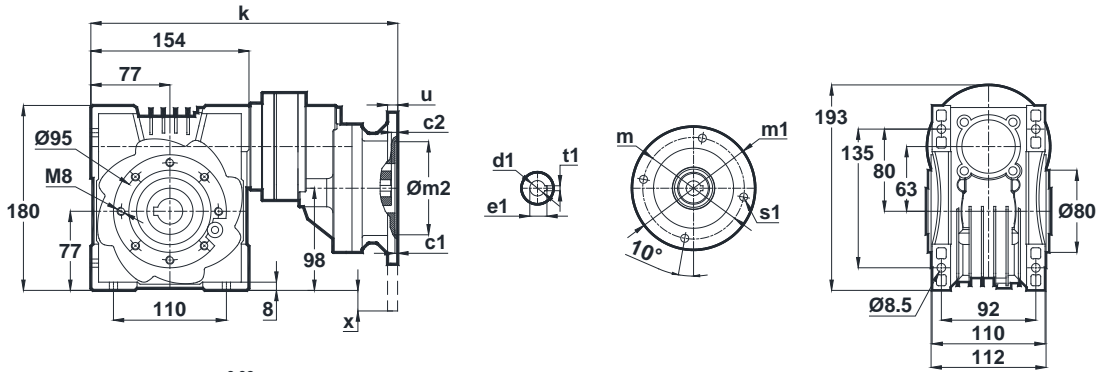

IEC	c1	c2	s1	m	m1	m2	u	k	d1	t1	e1	x
63/B5	3.5	5	10	115	140	95	10	291.7	11	4	12.8	-
63/B14	2.5	5	5.5	75	90	60	10	291.7	11	4	12.8	-
71/B5	4	4.5	11	130	160	110	12	293.2	14	5	16.3	-
71/B14	3	4.5	7	85	105	70	10	293.2	14	5	16.3	-
80/B5	4	5	12	165	200	130	12	308.2	19	6	21.8	2
80/B14	4	5	7	100	120	80	12	308.2	19	6	21.8	-
90/B5	4	5	12	165	200	130	12	308.2	24	8	27.3	2
90/B14	4	5	9	115	140	95	12	308.2	24	8	27.3	-

EV063.□ - NN01

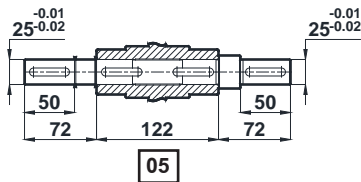
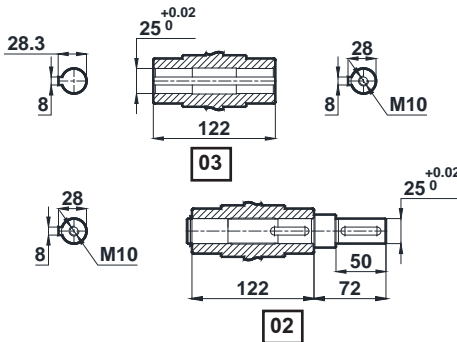
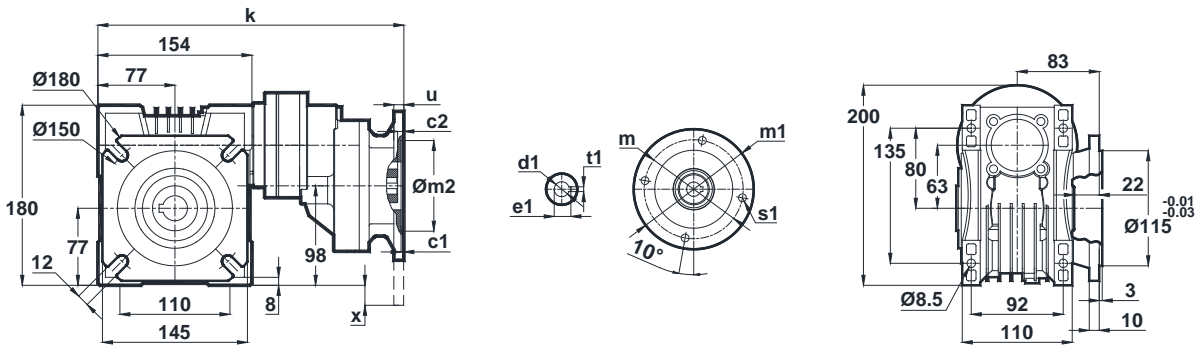

IEC	c1	c2	s1	m	m1	m2	u	k	d1	t1	e1	x
63/B5	3.5	5	10	115	140	95	10	291.7	11	4	12.8	-
63/B14	2.5	5	5.5	75	90	60	10	291.7	11	4	12.8	-
71/B5	4	4.5	11	130	160	110	12	293.2	14	5	16.3	-
71/B14	3	4.5	7	85	105	70	10	293.2	14	5	16.3	-
80/B5	4	5	12	165	200	130	12	308.2	19	6	21.8	2
80/B14	4	5	7	100	120	80	12	308.2	19	6	21.8	-
90/B5	4	5	12	165	200	130	12	308.2	24	8	27.3	2
90/B14	4	5	9	115	140	95	12	308.2	24	8	27.3	-

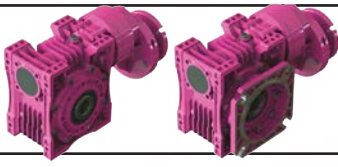

# Ölçü Sayfaları

## Dimension Pages

### Abmessungsseiten

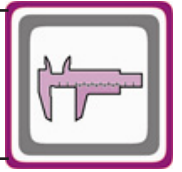

-Mil ucu çekirme deliği DIN 332 sayfa 2 / Tapped center hole to DIN 332, sheet 2 / Zentrierung mit Gewinde DIN 332, Blatt 2

EV075.□ - NN11

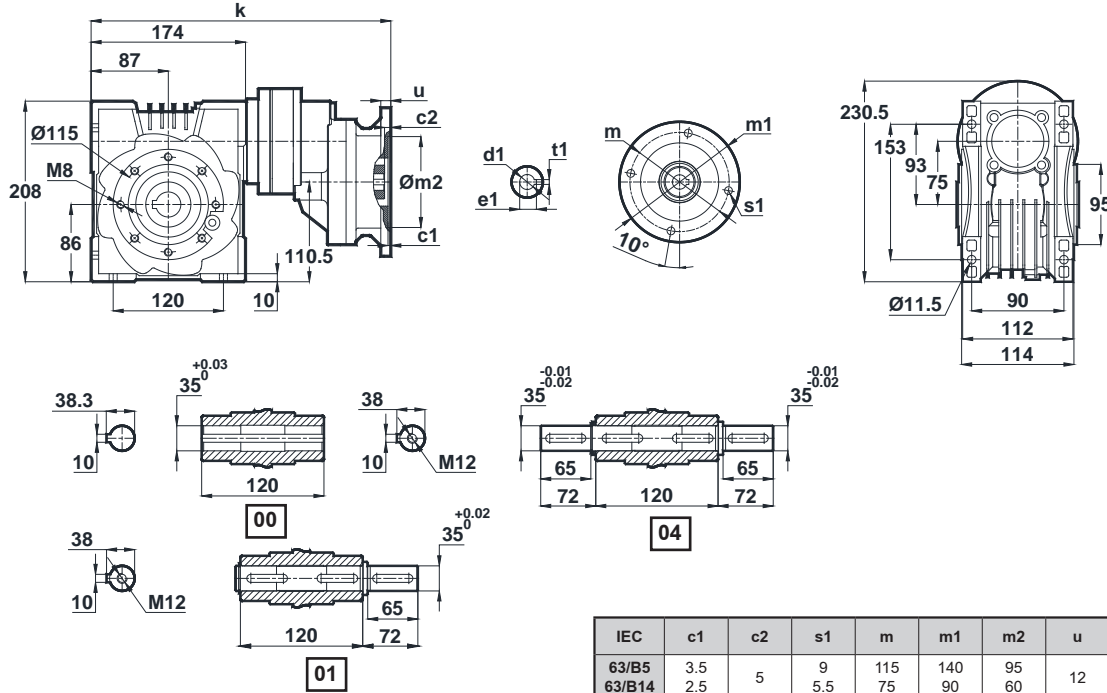

EV075.□ - NN11

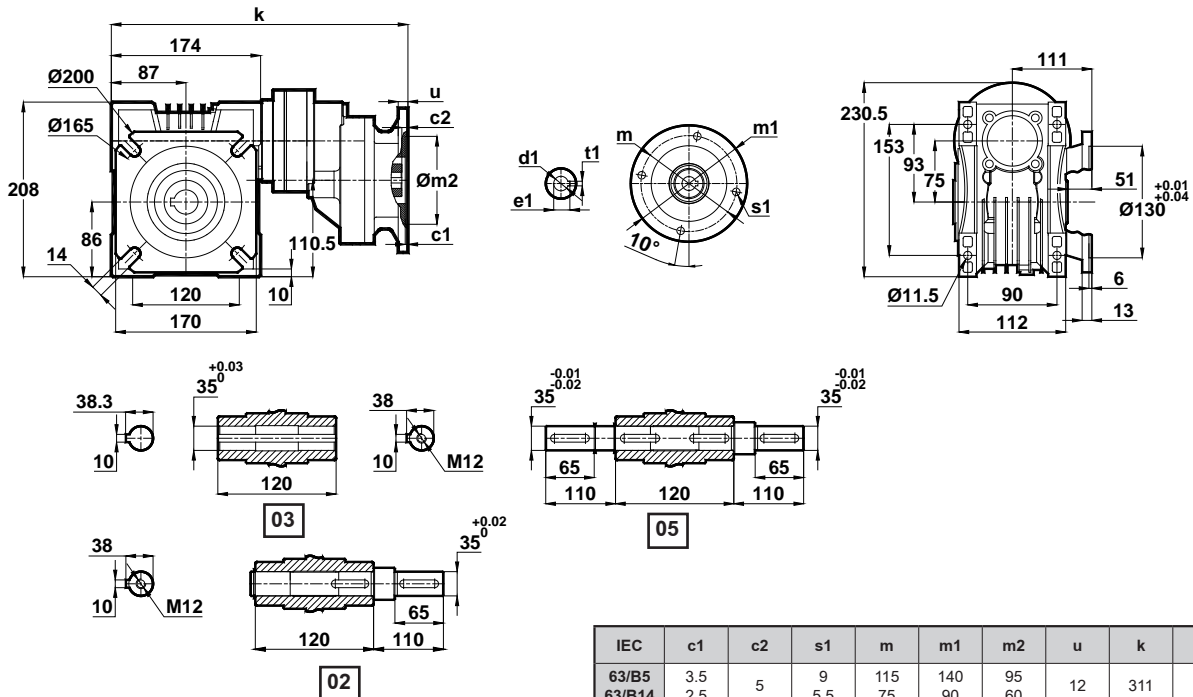

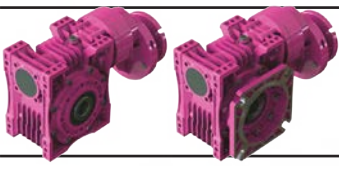

# Ölçü Sayfaları

## Dimension Pages

### Abmessungsseiten

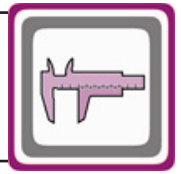

-Mil ucu çekirme deliği DIN 332 sayfa 2 / Tapped center hole to DIN 332, sheet 2 / Zentrierung mit Gewinde DIN 332, Blatt 2

EV080.□ - NN11

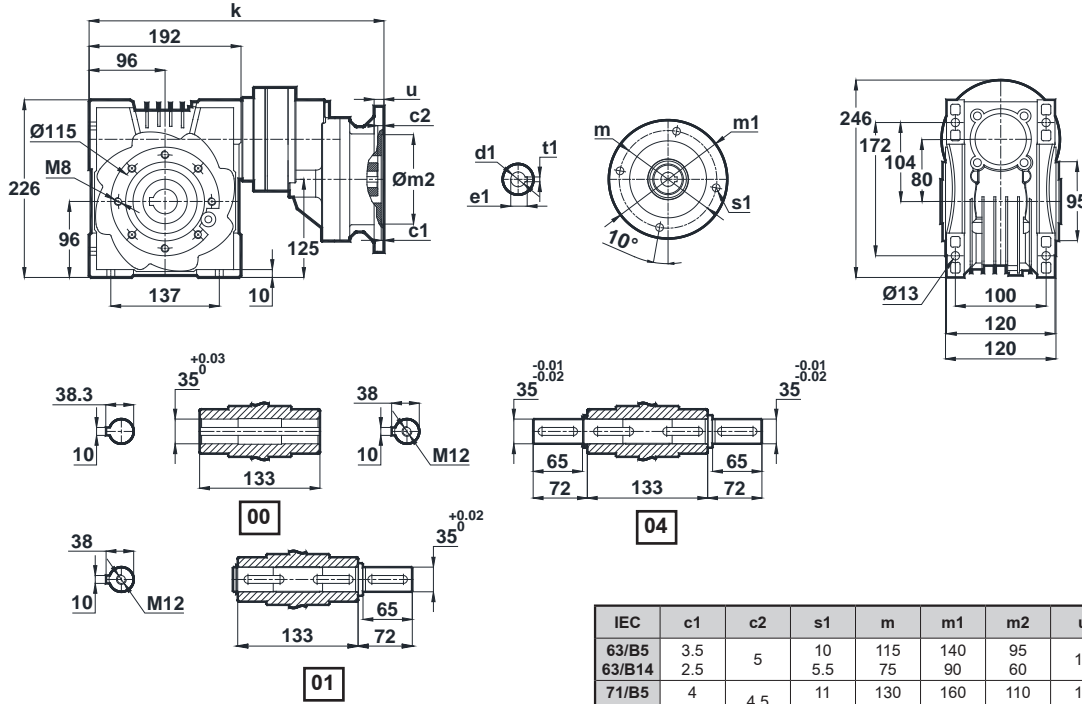

IEC	c1	c2	s1	m	m1	m2	u	k	d1	t1	e1
63/B5	3.5	5	10	115	140	95	10	329	11	4	12.8
63/B14	2.5	5	5.5	75	90	60	10	329	11	4	12.8
71/B5	4	4.5	11	130	160	110	12	329	14	5	16.3
71/B14	3	4.5	7	85	105	70	10	329	14	5	16.3
80/B5	4	5	12	165	200	130	12	344	19	6	21.8
80/B14	4	5	7	100	120	80	12	344	19	6	21.8
90/B5	4	5	12	165	200	130	12	344	24	8	27.3
90/B14	4	5	9	115	140	95	12	344	24	8	27.3

EV080.□ - NN11

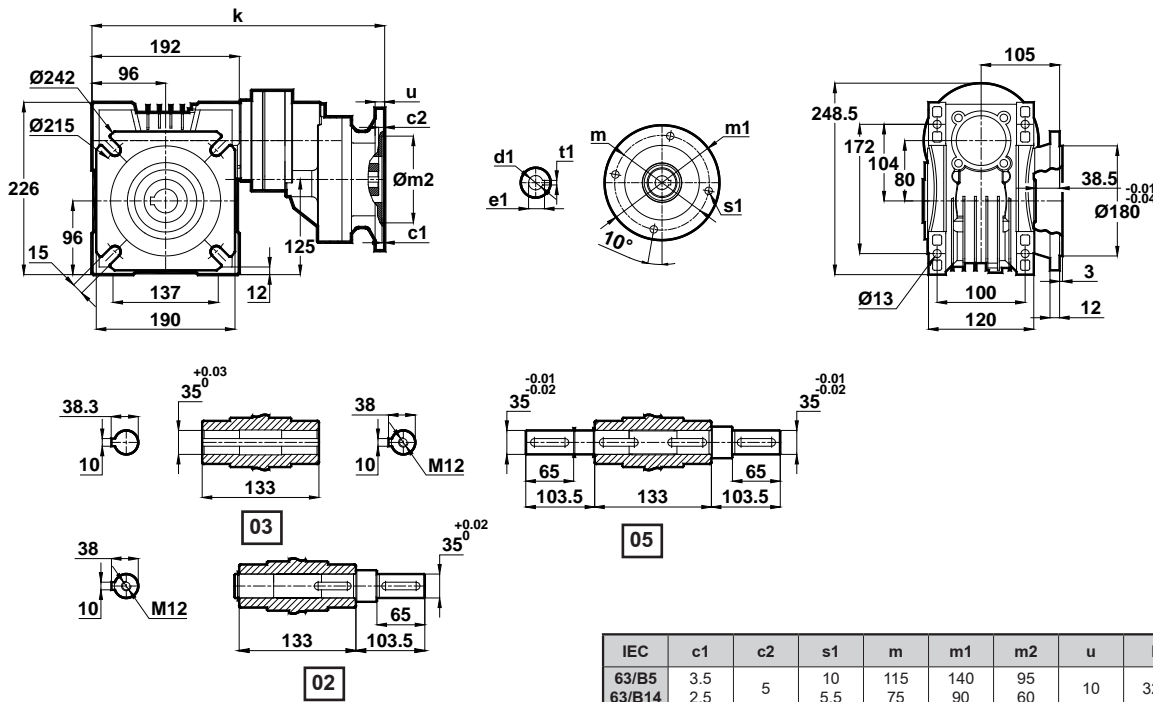

IEC	c1	c2	s1	m	m1	m2	u	k	d1	t1	e1
63/B5	3.5	5	10	115	140	95	10	329	11	4	12.8
63/B14	2.5	5	5.5	75	90	60	10	329	11	4	12.8
71/B5	4	4.5	11	130	160	110	12	329	14	5	16.3
71/B14	3	4.5	7	85	105	70	10	329	14	5	16.3
80/B5	4	5	12	165	200	130	12	344	19	6	21.8
80/B14	4	5	7	100	120	80	12	344	19	6	21.8
90/B5	4	5	12	165	200	130	12	344	24	8	27.3
90/B14	4	5	9	115	140	95	12	344	24	8	27.3

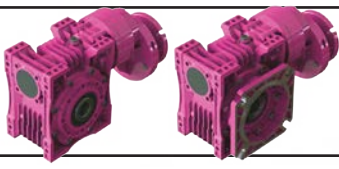

# Ölçü Sayfaları

## Dimension Pages

### Abmessungsseiten



-Mil ucu çekirme deliği DIN 332 sayfa 2 / Tapped center hole to DIN 332, sheet 2 / Zentrierung mit Gewinde DIN 332, Blatt 2

#### EV100.□ - NN11

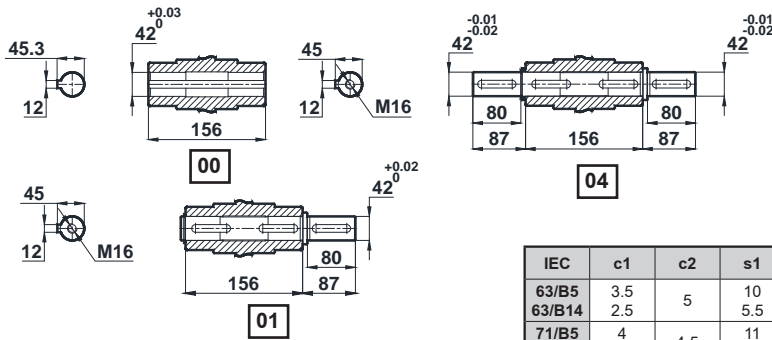
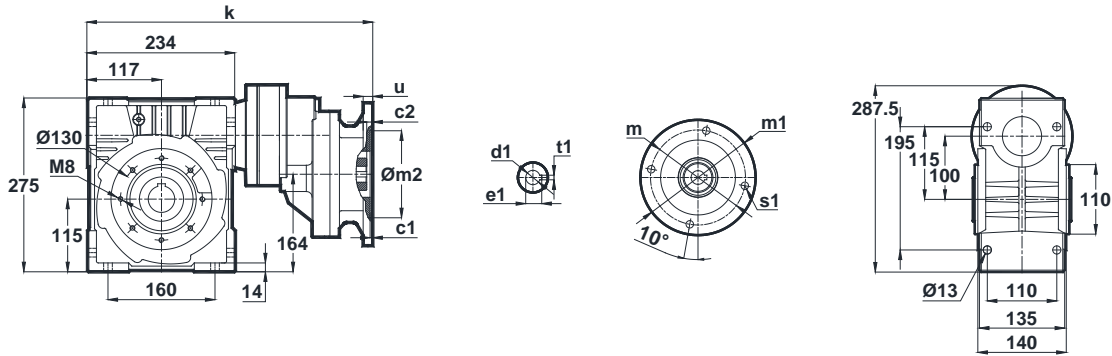

IEC	c1	c2	s1	m	m1	m2	u	k	d1	t1	e1
63/B5	3.5	5	10	115	140	95	10	371	11	4	12.8
63/B14	2.5	5	5.5	75	90	60	10	371	11	4	12.8
71/B5	4	4.5	11	130	160	110	12	371	14	5	16.3
71/B14	3	4.5	7	85	105	70	10	371	14	5	16.3
80/B5	4	5	12	165	200	130	12	386	19	6	21.8
80/B14	4	5	7	100	120	80	12	386	19	6	21.8
90/B5	4	5	12	165	200	130	12	386	24	8	27.3
90/B14	4	5	9	115	140	95	12	386	24	8	27.3

#### EV100.□ - NN11

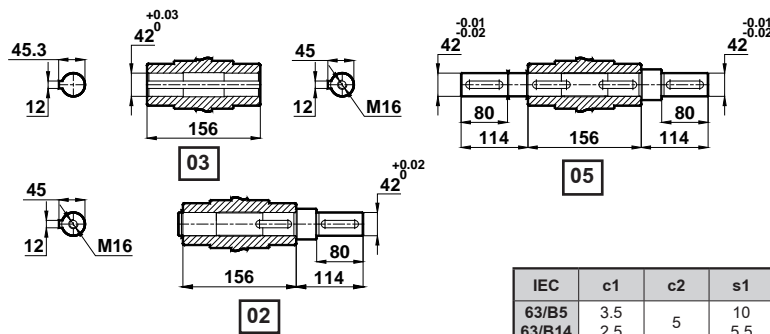
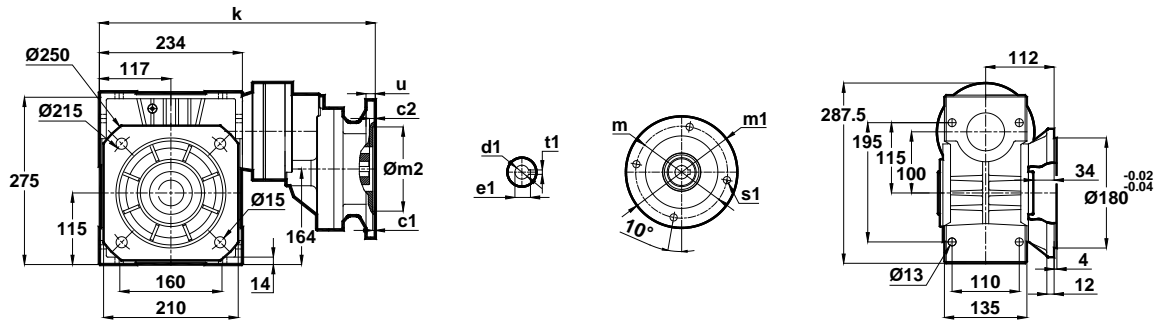

IEC	c1	c2	s1	m	m1	m2	u	k	d1	t1	e1
63/B5	3.5	5	10	115	140	95	10	371	11	4	12.8
63/B14	2.5	5	5.5	75	90	60	10	371	11	4	12.8
71/B5	4	4.5	11	130	160	110	12	371	14	5	16.3
71/B14	3	4.5	7	85	105	70	10	371	14	5	16.3
80/B5	4	5	12	165	200	130	12	386	19	6	21.8
80/B14	4	5	7	100	120	80	12	386	19	6	21.8
90/B5	4	5	12	165	200	130	12	386	24	8	27.3
90/B14	4	5	9	115	140	95	12	386	24	8	27.3

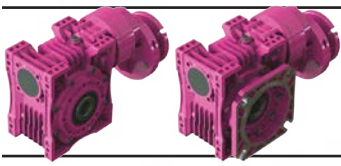

# Ölçü Sayfaları

## Dimension Pages

## Abmessungsseiten

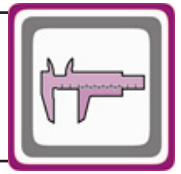

-Mil ucu çektirme deliği DIN 332 sayfa 2 / Tapped center hole to DIN 332, sheet 2 / Zentrierung mit Gewinde DIN 332, Blatt 2

EV125.□ - NN21

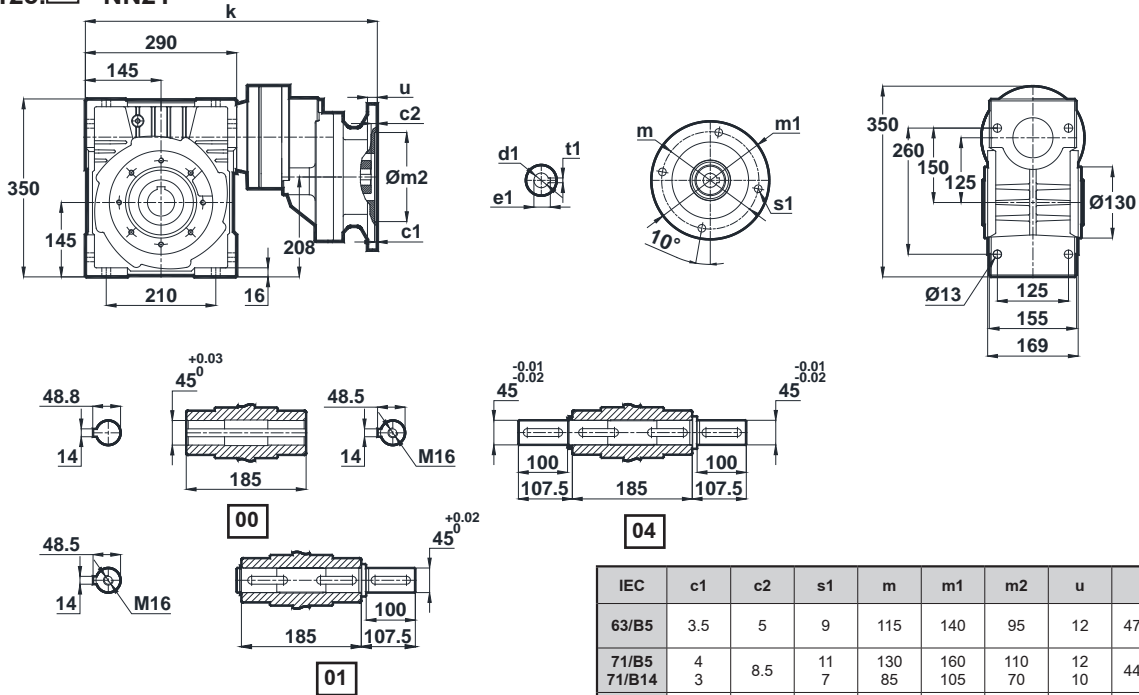

IEC	c1	c2	s1	m	m1	m2	u	k	d1	t1	e1
63/B5	3.5	5	9	115	140	95	12	474.5	11	4	12.8
71/B5	4	8.5	11	130	160	110	12	445.5	14	5	16.3
71/B14	3		7	85	105	70	10				
80/B5	4	5	12	165	200	130	12	474.5	19	6	21.8
80/B14	4	7	100	120	80						
90/B5	4	5	12	165	200	130	12	474.5	24	8	27.3
90/B14	4	9	115	140	95						
100/B5	4.5	5.5	15	215	250	180	12	467.5	28	8	31.3
100/B14	3.5		9	130	160	110					
112/B5	4.5	5.5	15	215	250	180	12	467.5	28	8	31.3
112/B14	3.5		9	130	160	110					

EV125.□ - NN21

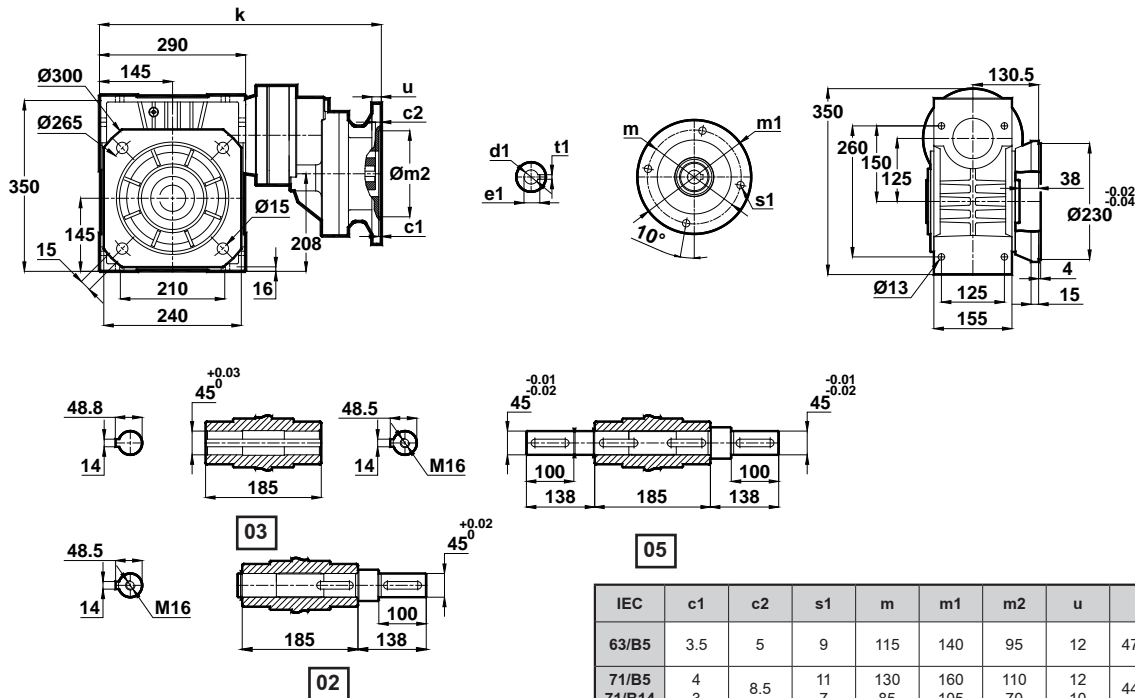

IEC	c1	c2	s1	m	m1	m2	u	k	d1	t1	e1
63/B5	3.5	5	9	115	140	95	12	474.5	11	4	12.8
71/B5	4	8.5	11	130	160	110	12	445.5	14	5	16.3
71/B14	3		7	85	105	70	10				
80/B5	4	5	12	165	200	130	12	474.5	19	6	21.8
80/B14	4	7	100	120	80						
90/B5	4	5	12	165	200	130	12	474.5	24	8	27.3
90/B14	4	9	115	140	95						
100/B5	4.5	5.5	15	215	250	180	12	467.5	28	8	31.3
100/B14	3.5		9	130	160	110					
112/B5	4.5	5.5	15	215	250	180	12	467.5	28	8	31.3
112/B14	3.5		9	130	160	110					

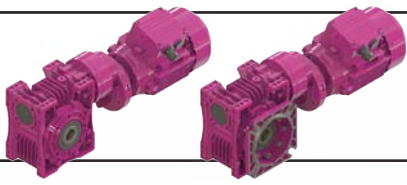

# Ölçü Sayfaları

## Dimension Pages

### Abmessungsseiten

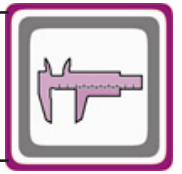

-Mil ucu çektirme deliği DIN 332 sayfa 2 / Tapped center hole to DIN 332, sheet 2 / Zentrierung mit Gewinde DIN 332, Blatt 2

EV050.□ - NV01

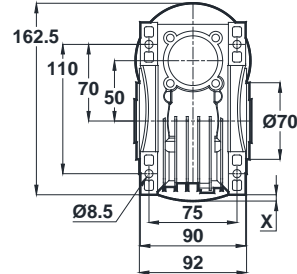
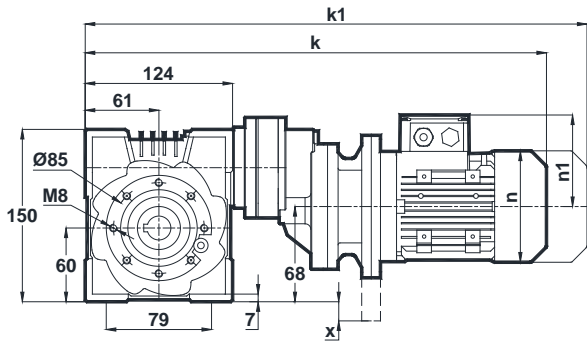

Klemens Pozisyonları  
Terminal Box Positions / Klemmenkasten

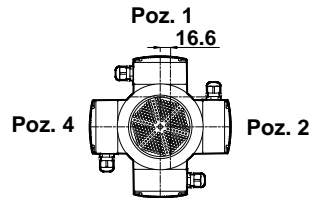

Poz. 1  
16.6

63-71-80-90  
Tip / Type / Typ

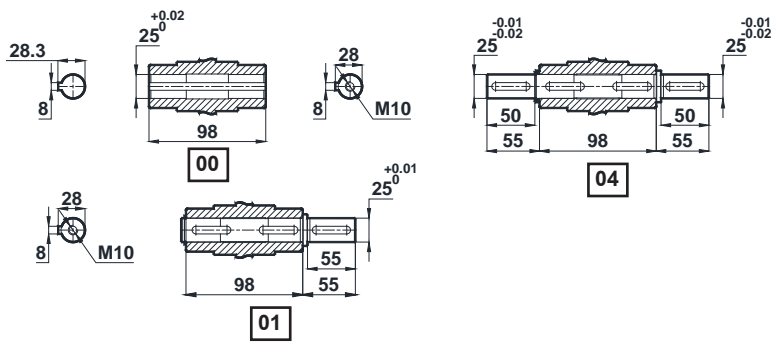

	k	k1	n	n1	x
63	416.2	477.2	121	97	-
71	444.7	535.7	137	112	0.5
80	478.7	571.7	155	121	9.5
90S	517.7	621.2	176	133	20
90L	517.7	621.2	176	133	20

EV050.□ - NV01

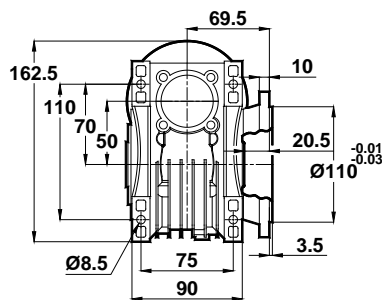
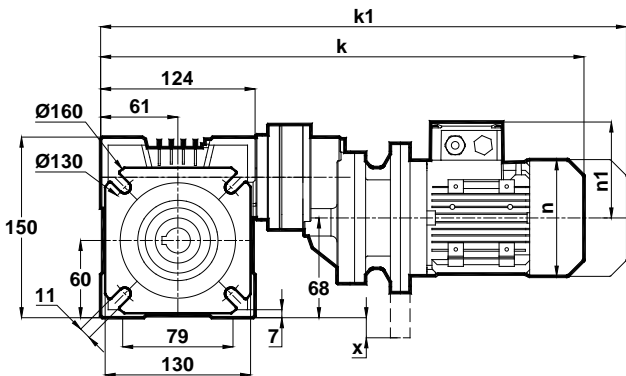

Klemens Pozisyonları  
Terminal Box Positions / Klemmenkasten

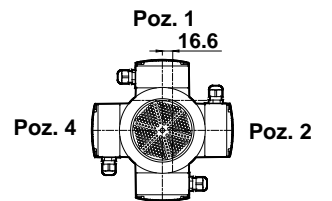

Poz. 1  
16.6

63-71-80-90  
Tip / Type / Typ

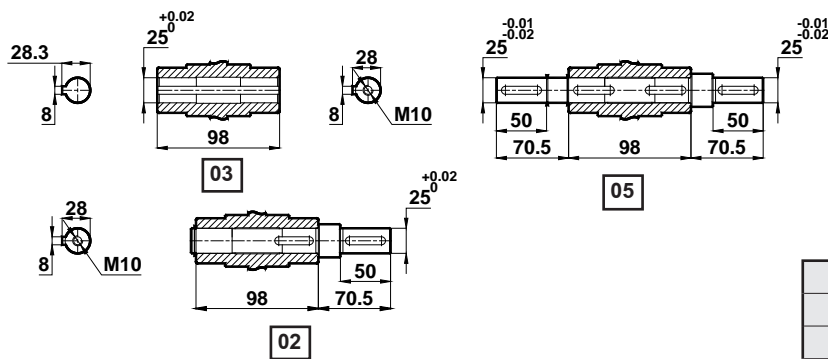

	k	k1	n	n1	x
63	416.2	477.2	121	97	-
71	444.7	535.7	137	112	0.5
80	478.7	571.7	155	121	9.5
90S	517.7	621.2	176	133	20
90L	517.7	621.2	176	133	20

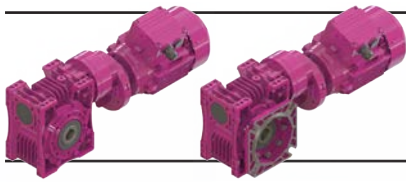

# Ölçü Sayfaları

## Dimension Pages

### Abmessungsseiten

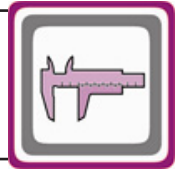

-Mil ucu çekirme deliği DIN 332 sayfa 2 / Tapped center hole to DIN 332, sheet 2 / Zentrierung mit Gewinde DIN 332, Blatt 2

EV063.□ - NV01

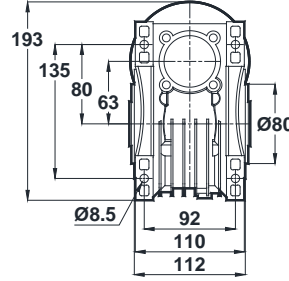
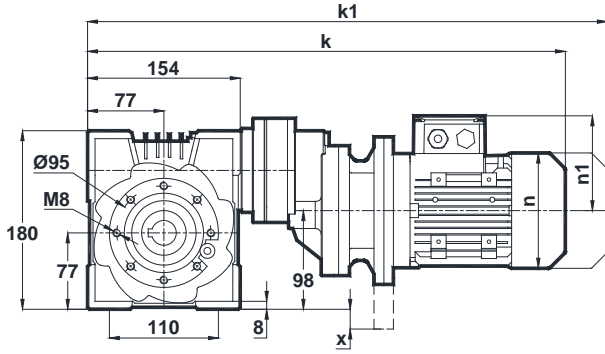

Klemens Pozisyonları  
Terminal Box Positions / Klemmenkasten

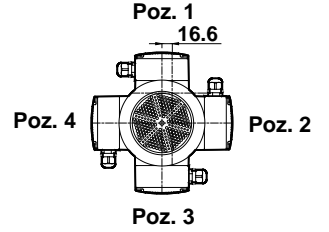

63-71-80-90  
Tip / Type / Typ

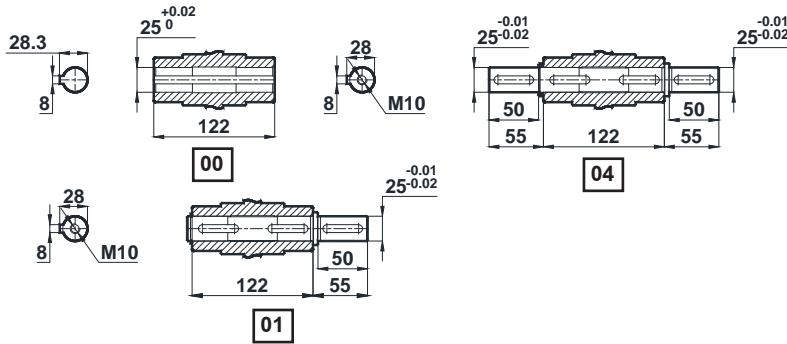

	k	k1	n	n1
63	446.2	507.2	121	97
71	474.7	565.7	137	112
80	508.7	601.7	155	121
90S	547.7	651.2	176	133
90L	547.7	651.2	176	133

EV063.□ - NV01

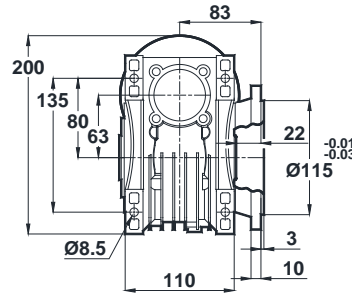
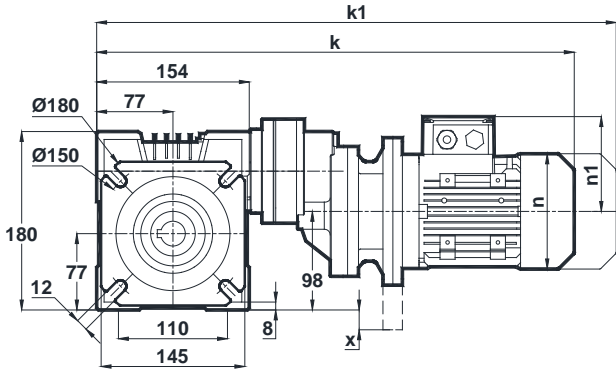

Klemens Pozisyonları  
Terminal Box Positions / Klemmenkasten

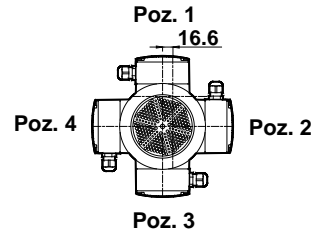

63-71-80-90  
Tip / Type / Typ

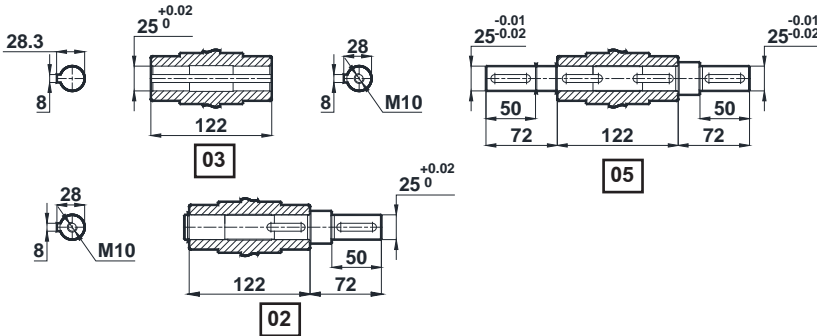

	k	k1	n	n1
63	446.2	507.2	121	97
71	474.7	565.7	137	112
80	508.7	601.7	155	121
90S	547.7	651.2	176	133
90L	547.7	651.2	176	133



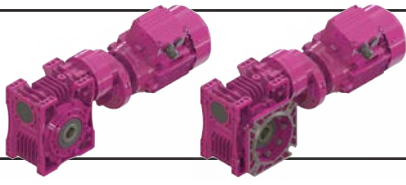

# Ölçü Sayfaları

## Dimension Pages

### Abmessungsseiten



-Mil ucu çekirme deliği DIN 332 sayfa 2 / Tapped center hole to DIN 332, sheet 2 / Zentrierung mit Gewinde DIN 332, Blatt 2

EV075.□ - NV11

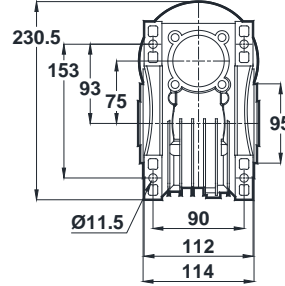
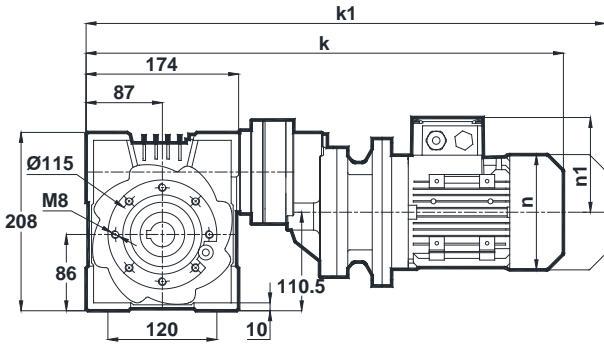

Klemens Pozisyonları  
Terminal Box Positions / Klemmenkasten

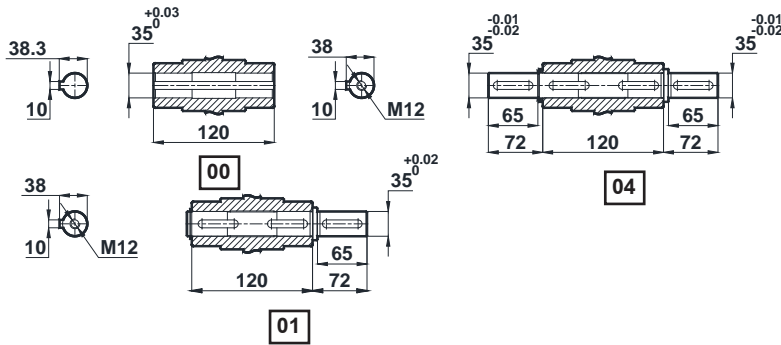
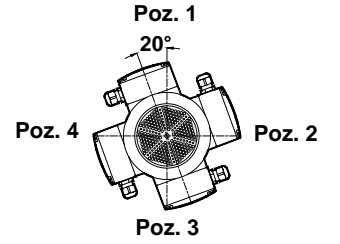

	k	k1	n	n1
63	464	525	121	97
71	492.5	583.5	137	112
80	526.5	619.5	155	121
90S	565.5	669	176	133
90L	565.5	669	176	133

EV075.□ - NV11

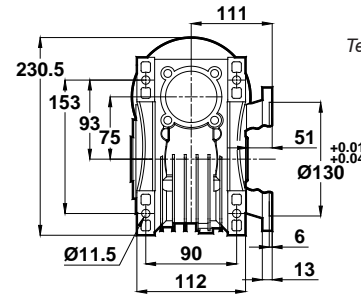
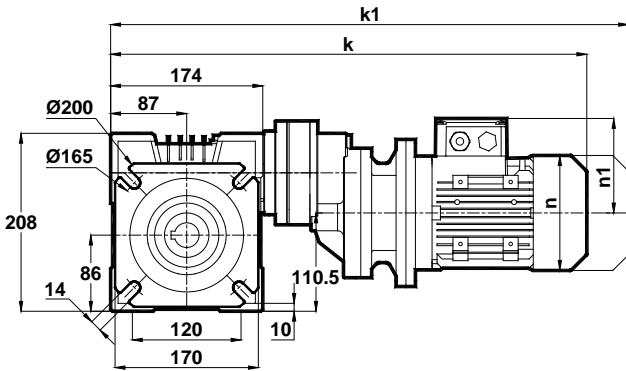

Klemens Pozisyonları  
Terminal Box Positions / Klemmenkasten

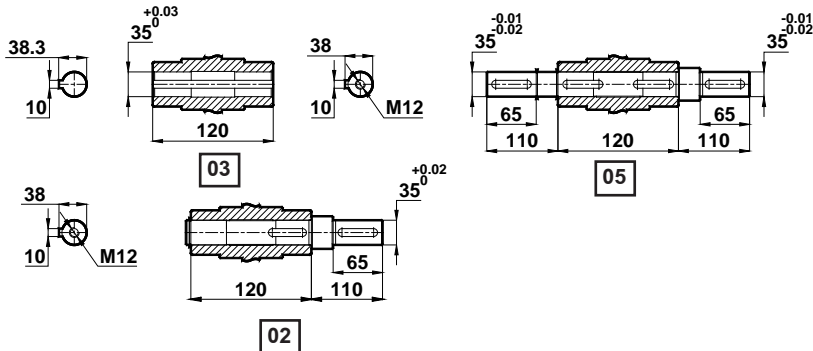
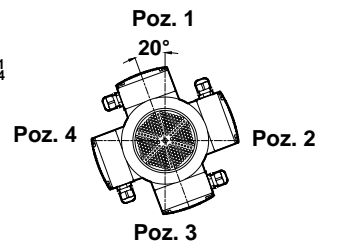

	k	k1	n	n1
63	464	525	121	97
71	492.5	583.5	137	112
80	526.5	619.5	155	121
90S	565.5	669	176	133
90L	565.5	669	176	133

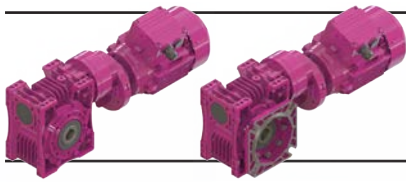

# Ölçü Sayfaları

## Dimension Pages

## Abmessungsseiten

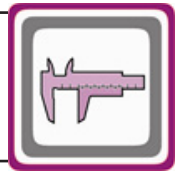

-Mil ucu çekirme deliği DIN 332 sayfa 2 / Tapped center hole to DIN 332, sheet 2 / Zentrierung mit Gewinde DIN 332, Blatt 2

EV080.□ - NV11

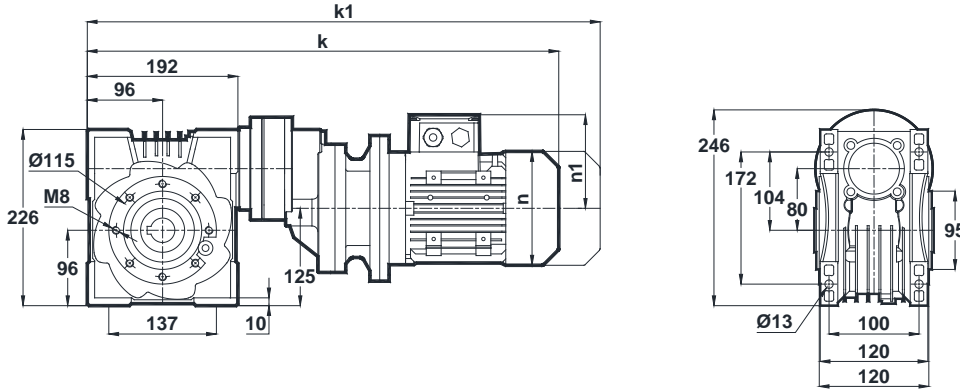

**Klemens Pozisyonları**  
Terminal Box Positions / Klemmenkasten

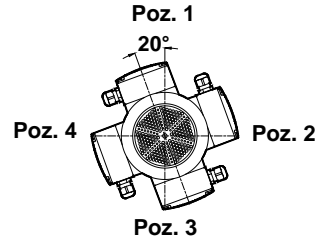

**63-71-80-90**  
Tip / Type / Typ

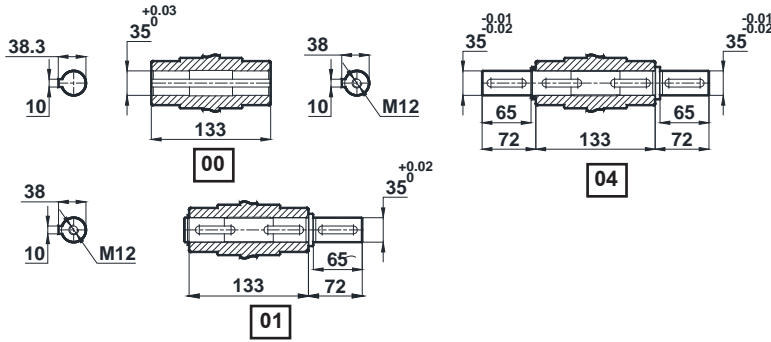

	k	k1	n	n1
63	482	543	121	97
71	510.5	601.5	137	112
80	544.5	637.5	155	121
90S	583.5	687	176	133
90L	583.5	687	176	133

EV080.□ - NV11

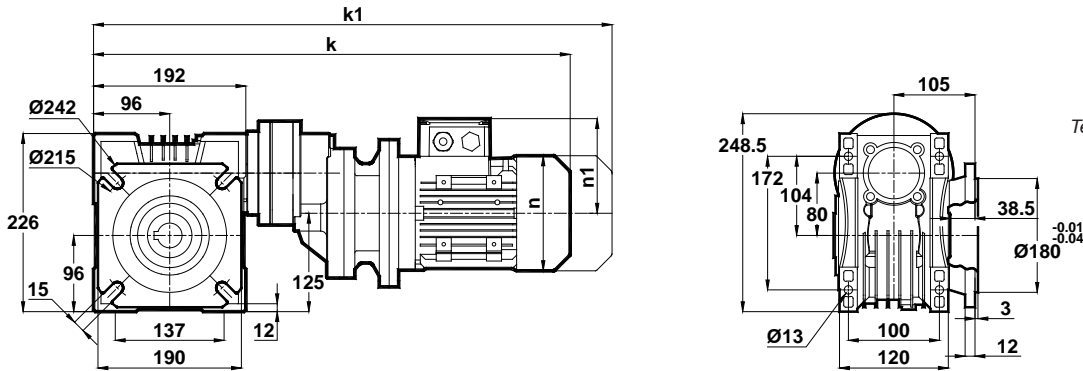

**Klemens Pozisyonları**  
Terminal Box Positions / Klemmenkasten

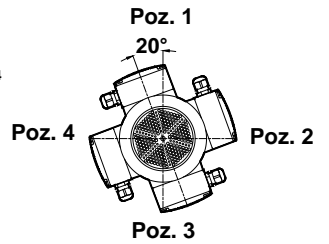

**63-71-80-90**  
Tip / Type / Typ

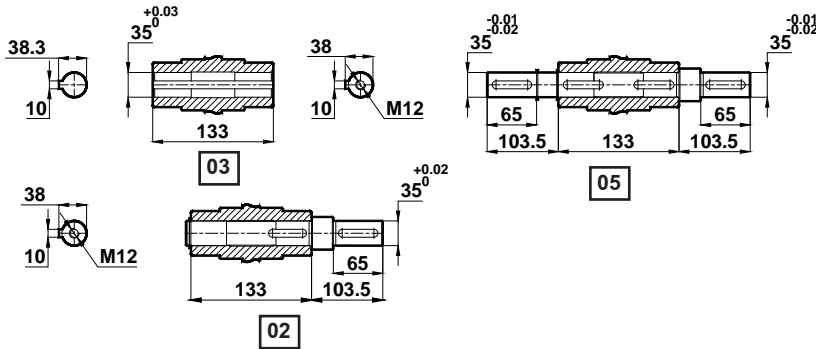

	k	k1	n	n1
63	482	543	121	97
71	510.5	601.5	137	112
80	544.5	637.5	155	121
90S	583.5	687	176	133
90L	583.5	687	176	133

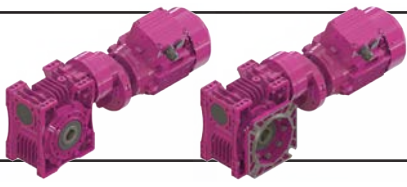

# Ölçü Sayfaları

## Dimension Pages

### Abmessungsseiten

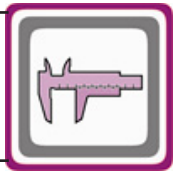

-Mil ucu çekirme deliği DIN 332 sayfa 2 / Tapped center hole to DIN 332, sheet 2 / Zentrierung mit Gewinde DIN 332, Blatt 2

EV100.□ - NV11

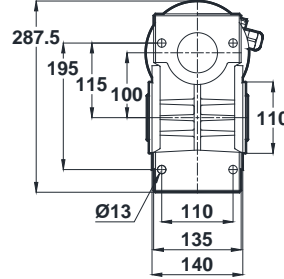
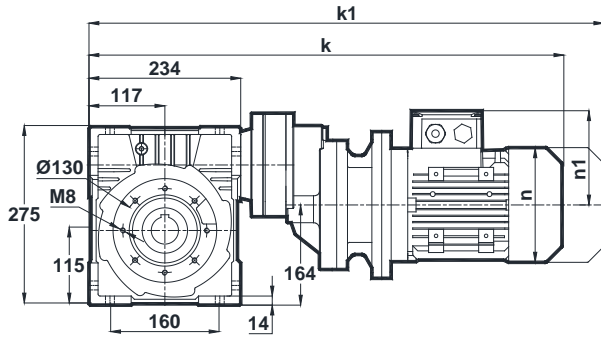

Klemens Pozisyonları  
Terminal Box Positions / Klemmenkasten

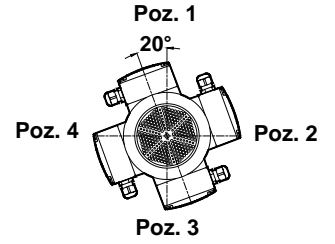

63-71-80-90  
Tip / Type / Typ

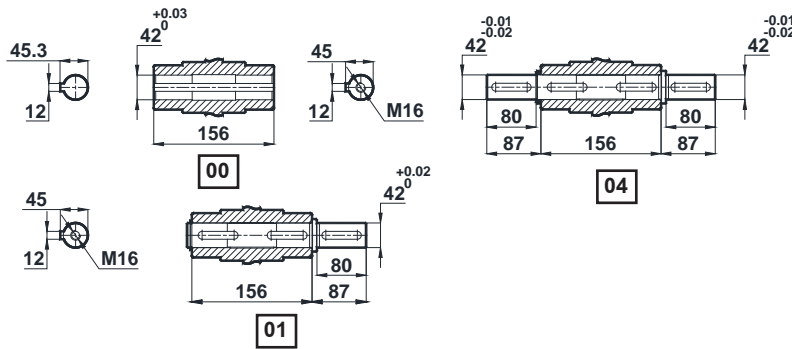

	k	k1	n	n1
63	524	585	121	97
71	552.5	643.5	137	112
80	586.5	679.5	155	121
90S	625.5	729	176	133
90L	625.5	729	176	133

EV100.□ - NV11

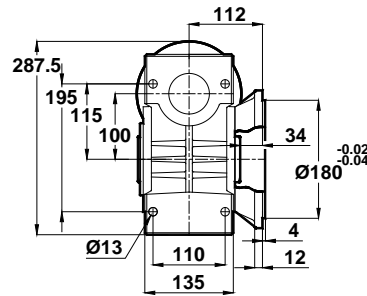
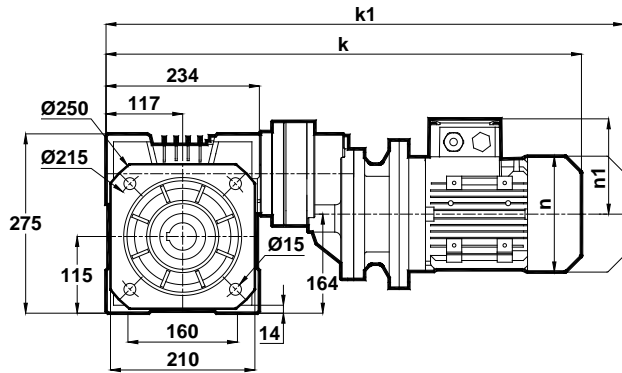

Klemens Pozisyonları  
Terminal Box Positions / Klemmenkasten

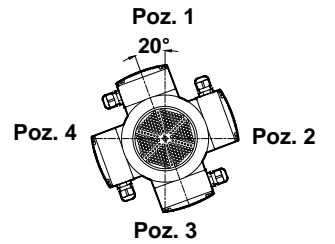

63-71-80-90  
Tip / Type / Typ

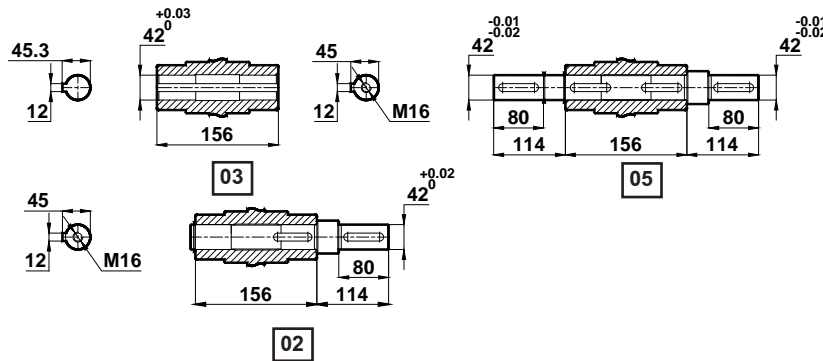

	k	k1	n	n1
63	524	585	121	97
71	552.5	643.5	137	112
80	586.5	679.5	155	121
90S	625.5	729	176	133
90L	625.5	729	176	133

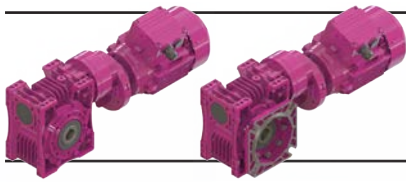

# Ölçü Sayfaları

## Dimension Pages

### Abmessungsseiten

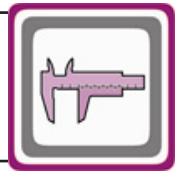

-Mil ucu çekirme deliği DIN 332 sayfa 2 / Tapped center hole to DIN 332, sheet 2 / Zentrierung mit Gewinde DIN 332, Blatt 2

EV125.□ - NV21

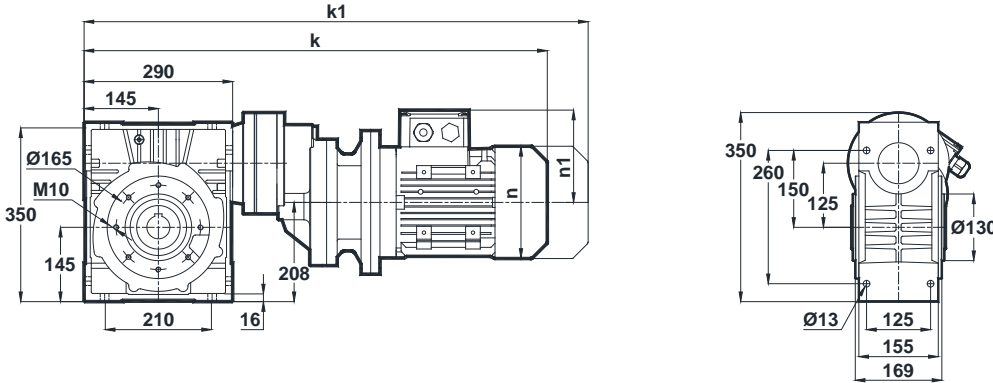

**Klemens Pozisyonları**  
Terminal Box Positions / Klemmenkasten

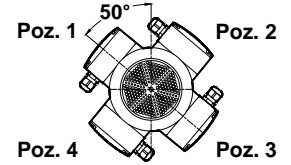

63-71-80-90-100-112  
Tip / Type / Typ

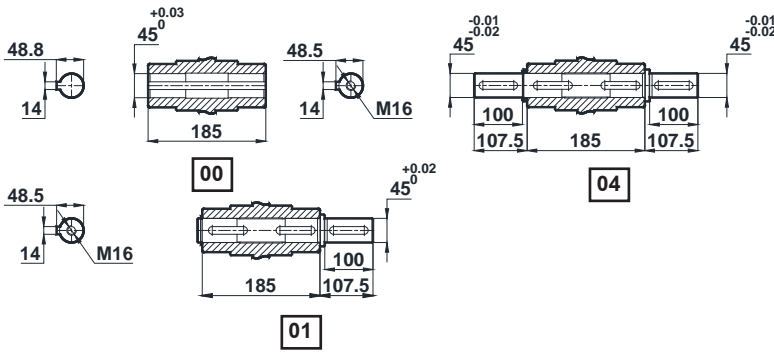

	k	k1	n	n1
63	595	656	121	97
71	622	713	137	112
80	656	749	155	121
90S	695	798.5	176	133
90L	695	798.5	176	133
100L	743	851.5	193	147
112M	767	871.5	215	158

EV125.□ - NV21

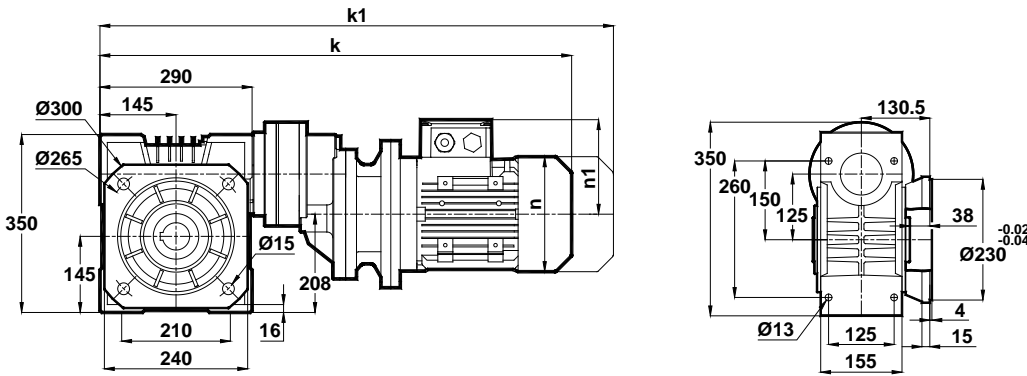

**Klemens Pozisyonları**  
Terminal Box Positions / Klemmenkasten

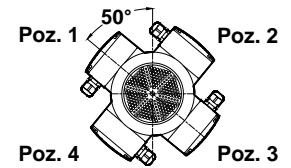

63-71-80-90-100-112  
Tip / Type / Typ

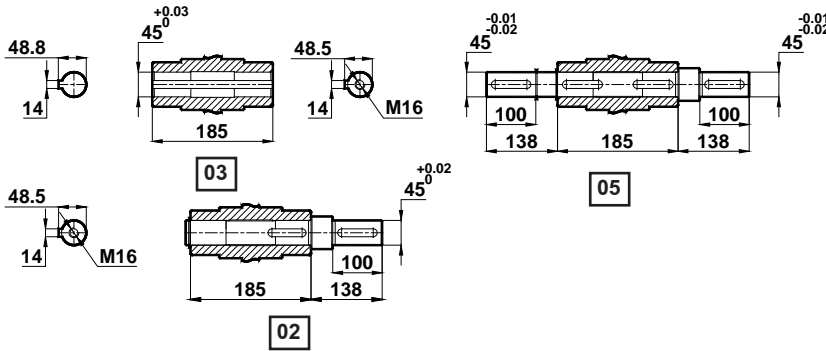

	k	k1	n	n1
63	595	656	121	97
71	622	713	138	112
80	656	749	156	121
90S	695	798.5	176	133
90L	695	798.5	176	133
100L	743	851.5	194	147
112M	767	871.5	218	158



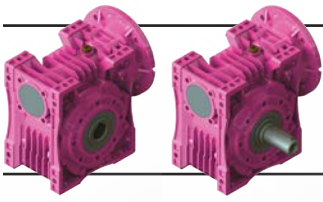

# Ölçü Sayfaları

## Dimension Pages

### Abmessungsseiten

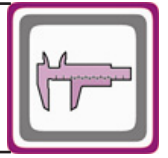

-Mil ucu çekirme deliği DIN 332 sayfa 2 / Tapped center hole to DIN 332, sheet 2 / Zentrierung mit Gewinde DIN 332, Blatt 2

#### EN030.00

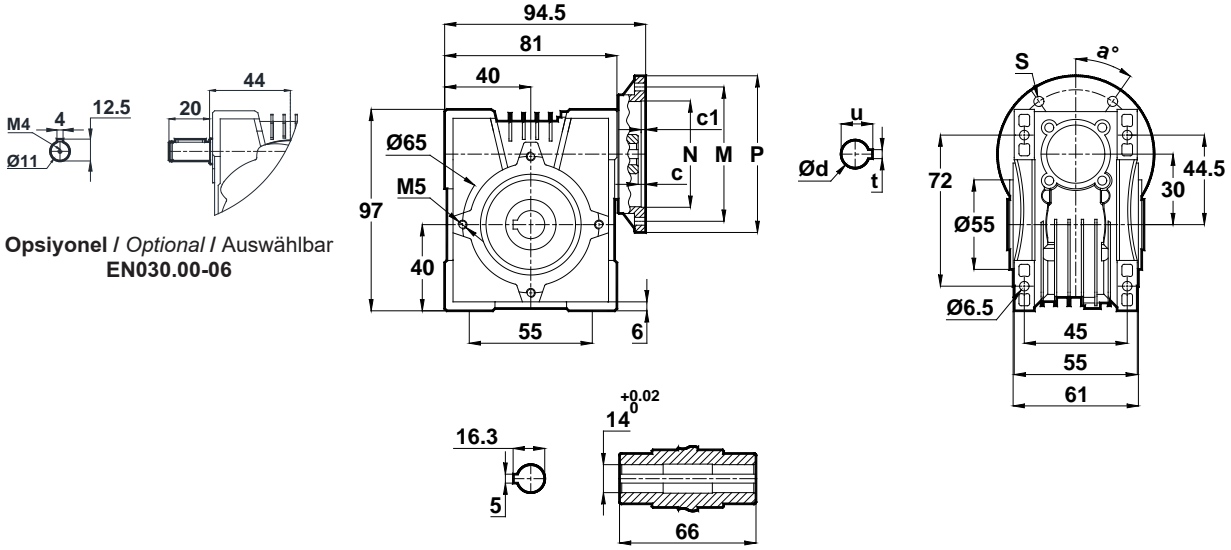

#### EN030.01

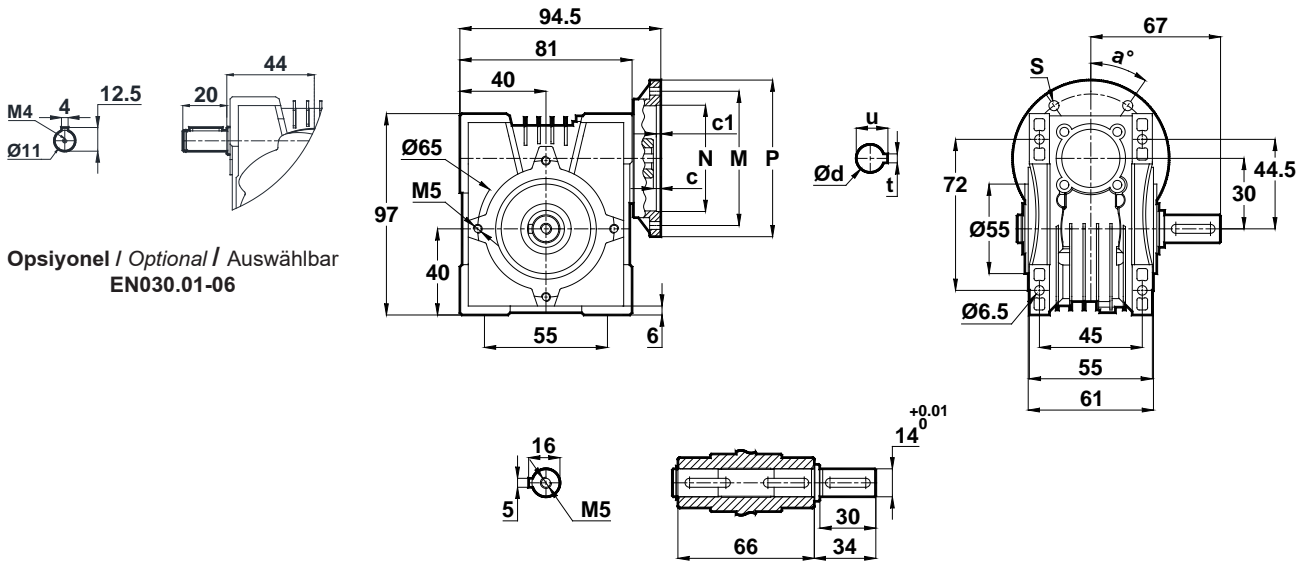

EN030	c	c1	N	M	P	d	u	t	a	s
56/B14	4.2	3	50	65	80	9	10.4	3	45°	5.5
63/B14	4.2	2.5	60	75	90	11	12.8	4	45°	5.5
63/B5	4.2	3.5	95	115	140	11	12.8	4	45°	10

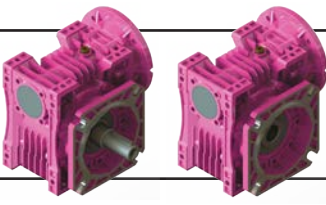

# Ölçü Sayfaları

## Dimension Pages

### Abmessungsseiten

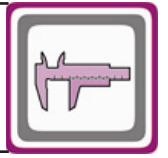

-Mil ucu çekirme deliği DIN 332 sayfa 2 / Tapped center hole to DIN 332, sheet 2 / Zentrierung mit Gewinde DIN 332, Blatt 2

#### EN030.02

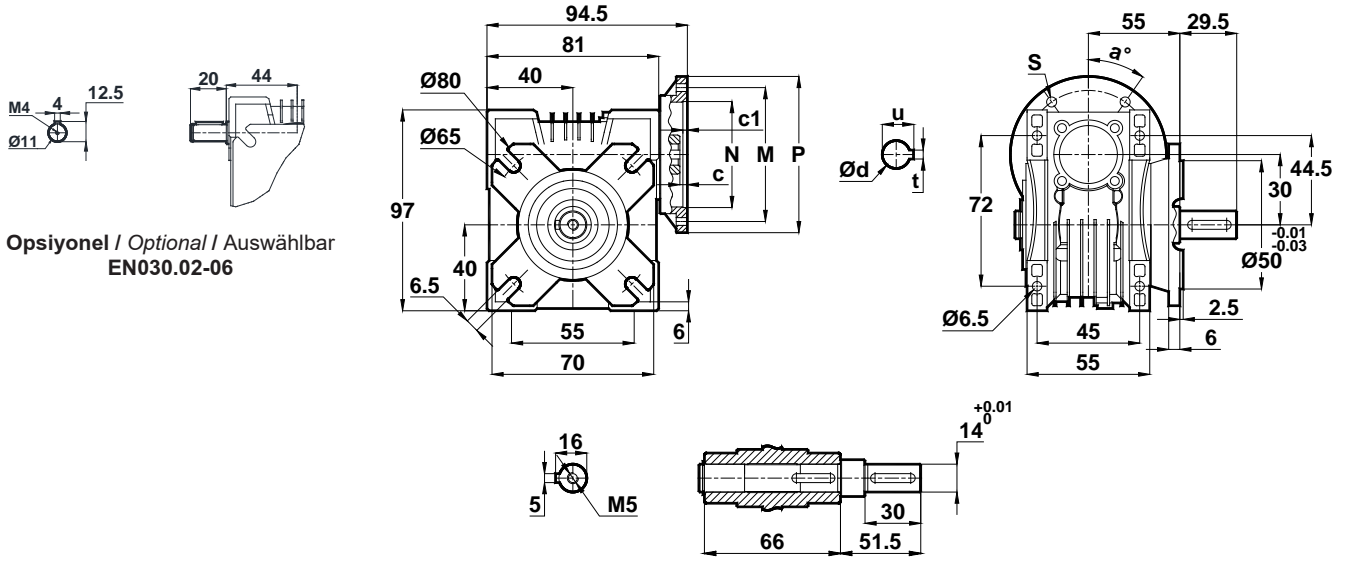

#### EN030.03

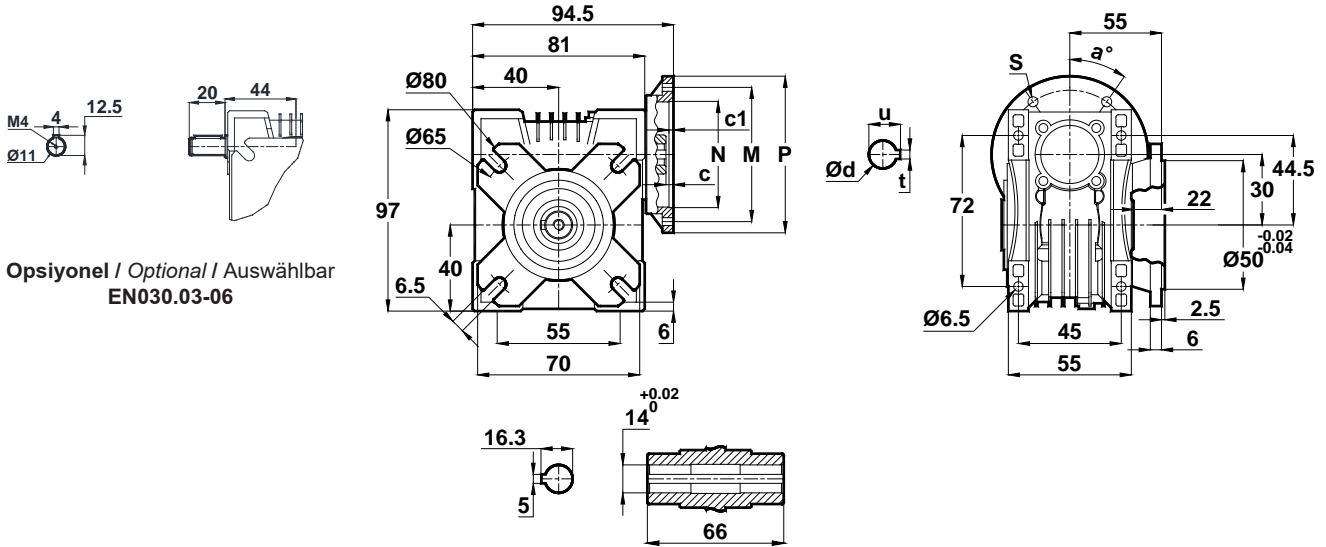

EN030	c	c1	N	M	P	d	u	t	a	s
56/B14	4.2	3	50	65	80	9	10.4	3	45°	5.5
63/B14	4.2	2.5	60	75	90	11	12.8	4	45°	5.5
63/B5	4.2	3.5	95	115	140	11	12.8	4	45°	10

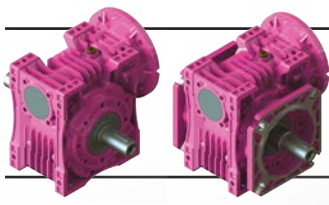

# Ölçü Sayfaları

## Dimension Pages

### Abmessungsseiten

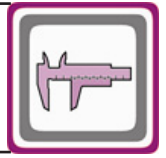

-Mil ucu çekirme deliği DIN 332 sayfa 2 / Tapped center hole to DIN 332, sheet 2 / Zentrierung mit Gewinde DIN 332, Blatt 2

#### EN030.04

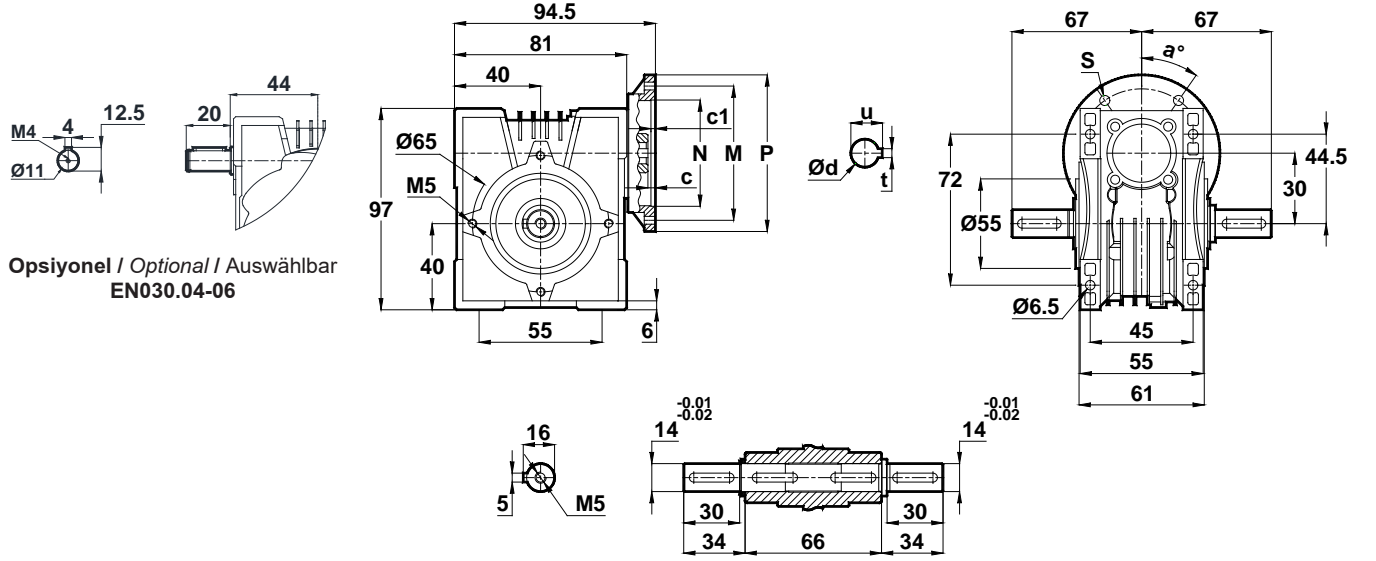

#### EN030.05

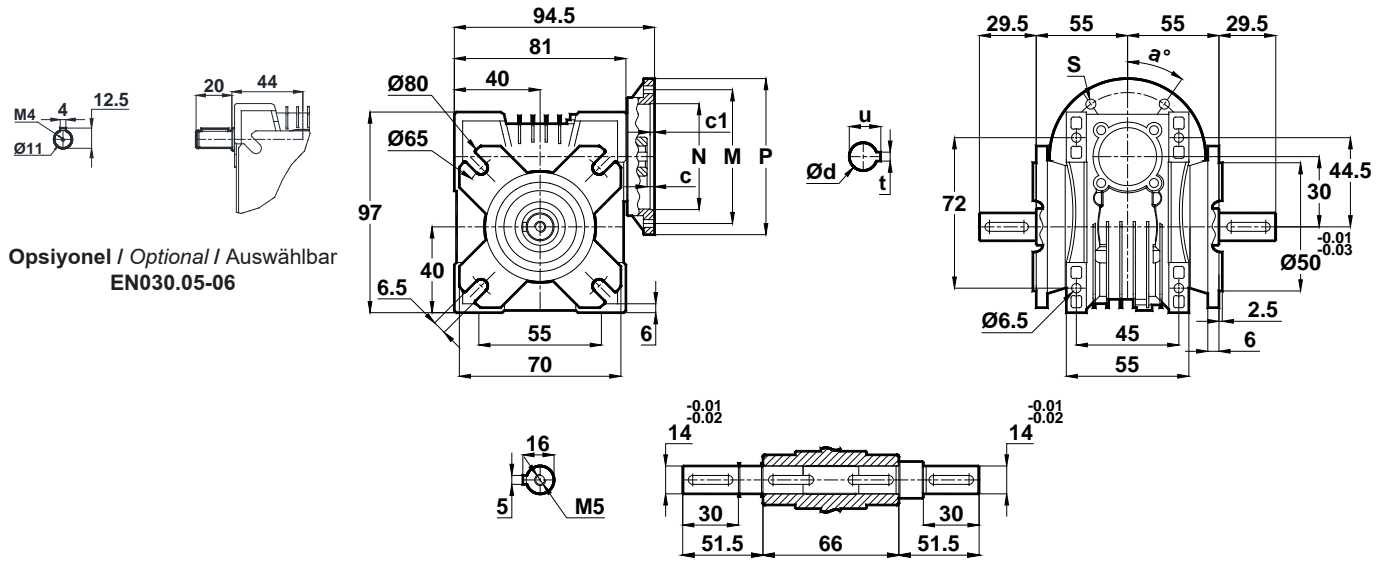

EN030	c	c1	N	M	P	d	u	t	a	s
56/B14	4.2	3	50	65	80	9	10.4	3	45°	5.5
63/B14	4.2	2.5	60	75	90	11	12.8	4	45°	5.5
63/B5	4.2	3.5	95	115	140	11	12.8	4	45°	10





# Ölçü Sayfaları

## Dimension Pages

### Abmessungsseiten

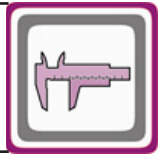

-Mil ucu çekirme deliği DIN 332 sayfa 2 / Tapped center hole to DIN 332, sheet 2 / Zentrierung mit Gewinde DIN 332, Blatt 2

EN030.08

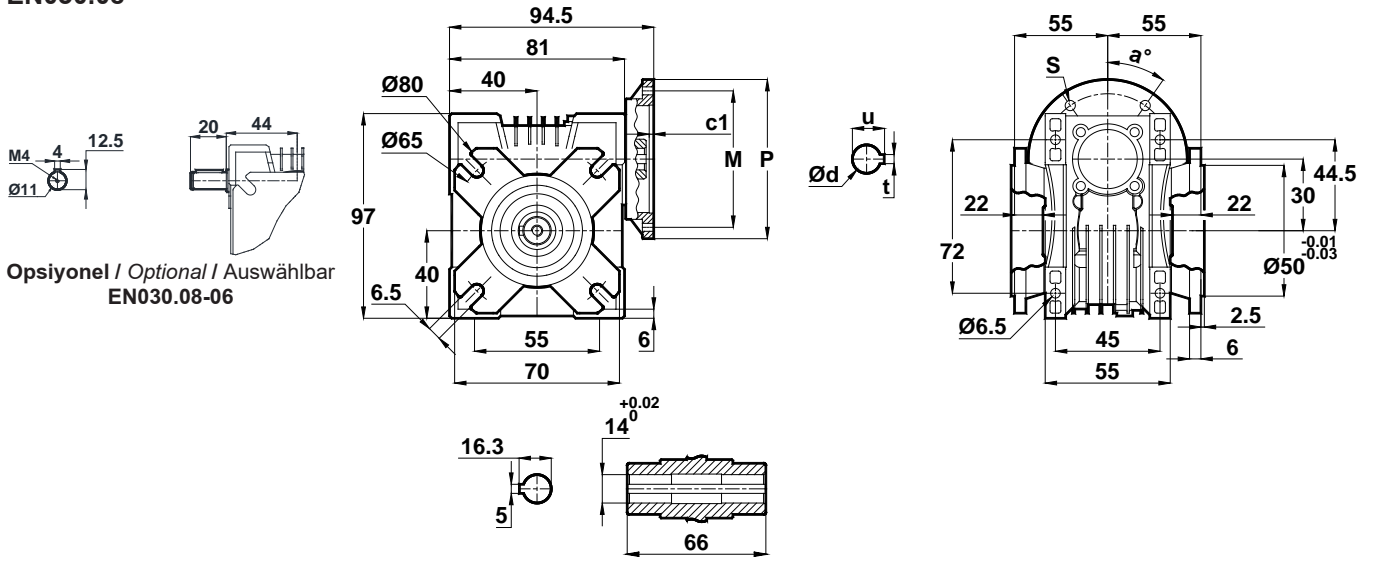

EN030	c	c1	N	M	P	d	u	t	a	s
56/B14	4.2	3	50	65	80	9	10.4	3	45°	5.5
63/B14	4.2	2.5	60	75	90	11	12.8	4	45°	5.5
63/B5	4.2	3.5	95	115	140	11	12.8	4	45°	10

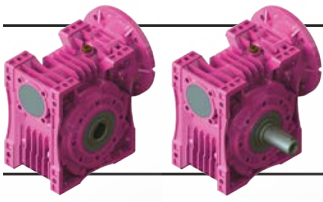

# Ölçü Sayfaları

## Dimension Pages

### Abmessungsseiten

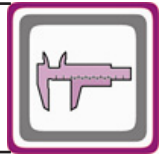

-Mil ucu çekirme deliği DIN 332 sayfa 2 / Tapped center hole to DIN 332, sheet 2 / Zentrierung mit Gewinde DIN 332, Blatt 2

#### EN040.00

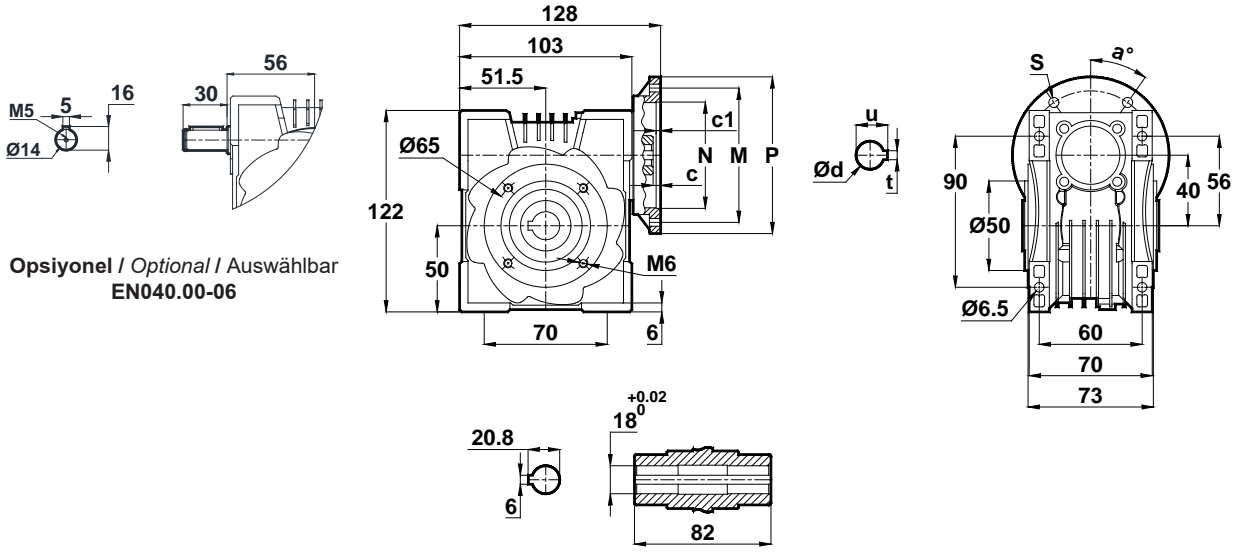

#### EN040.01

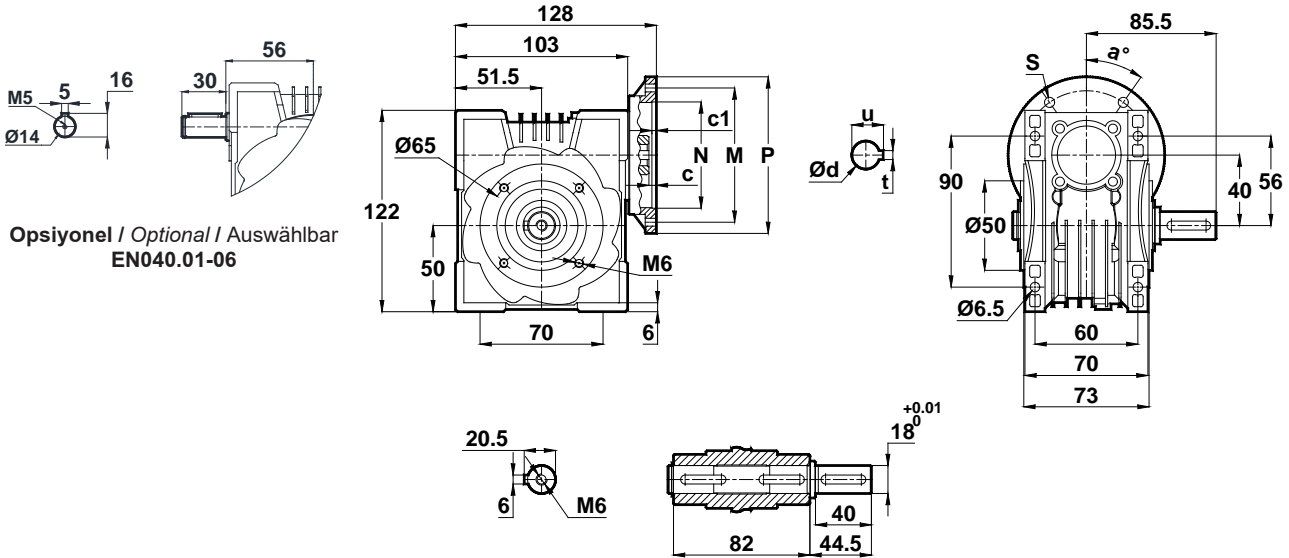

EN040	c	c1	N	M	P	d	u	t	a	s
63/B14	4	2.5	60	75	90	11	12.8	4	45°	5.5
71/B14	4	3	70	85	105	14	16.3	5	45°	10
63/B5	4	3.5	95	115	140	11	12.8	4	45°	10
71/B5	4	4	110	130	160	14	16.3	5	45°	10

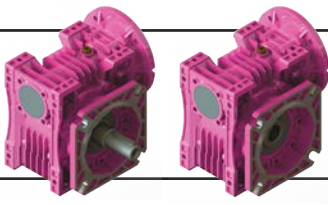

# Ölçü Sayfaları

## Dimension Pages

### Abmessungsseiten

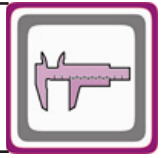

-Mil ucu çekirme deliği DIN 332 sayfa 2 / Tapped center hole to DIN 332, sheet 2 / Zentrierung mit Gewinde DIN 332, Blatt 2

#### EN040.02

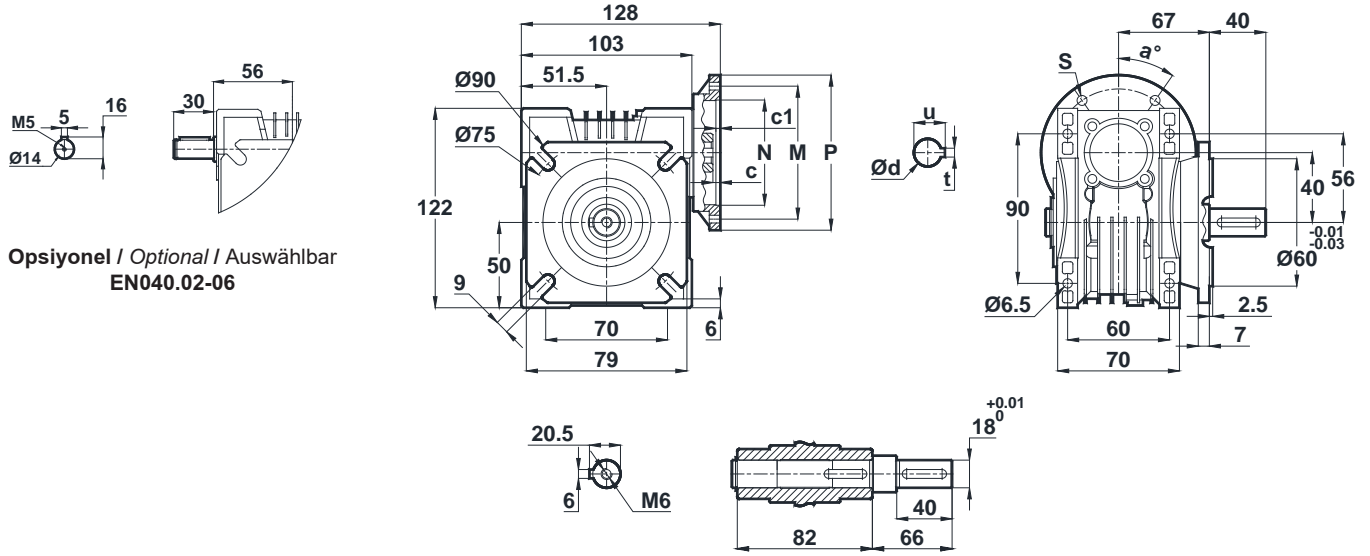

#### EN040.03

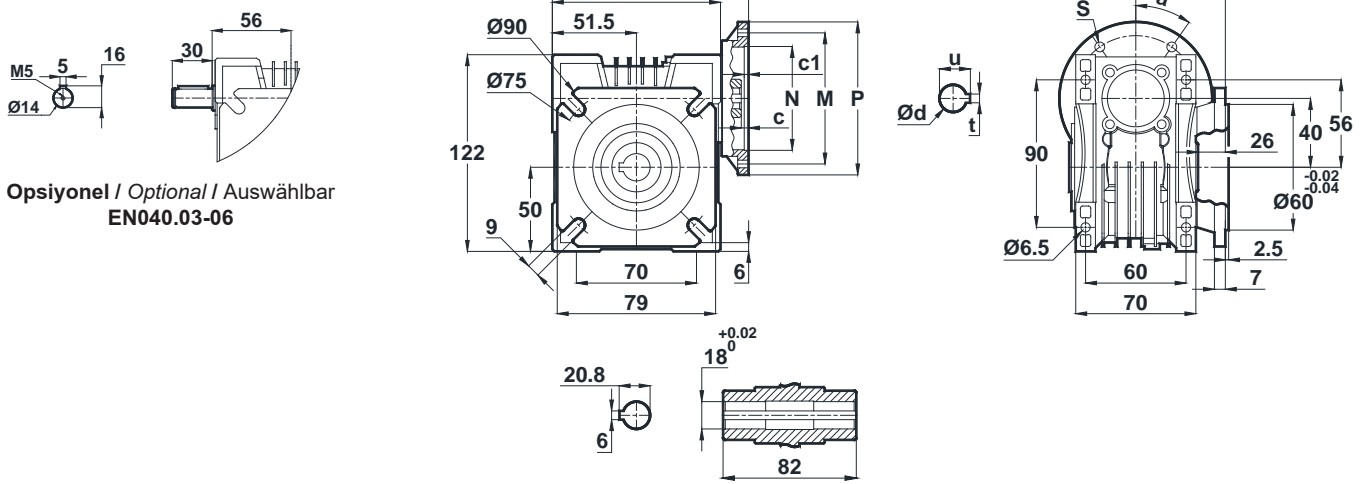

EN040	c	c1	N	M	P	d	u	t	a	s
63/B14	4	2.5	60	75	90	11	12.8	4	45°	5.5
71/B14	4	3	70	85	105	14	16.3	5	45°	10
63/B5	4	3.5	95	115	140	11	12.8	4	45°	10
71/B5	4	4	110	130	160	14	16.3	5	45°	10

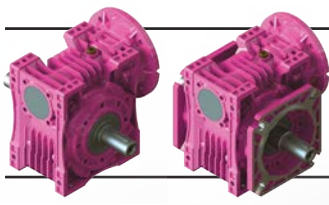

# Ölçü Sayfaları

## Dimension Pages

### Abmessungsseiten

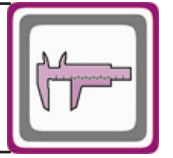

-Mil ucu çekirme deliği DIN 332 sayfa 2 / Tapped center hole to DIN 332, sheet 2 / Zentrierung mit Gewinde DIN 332, Blatt 2

#### EN040.04

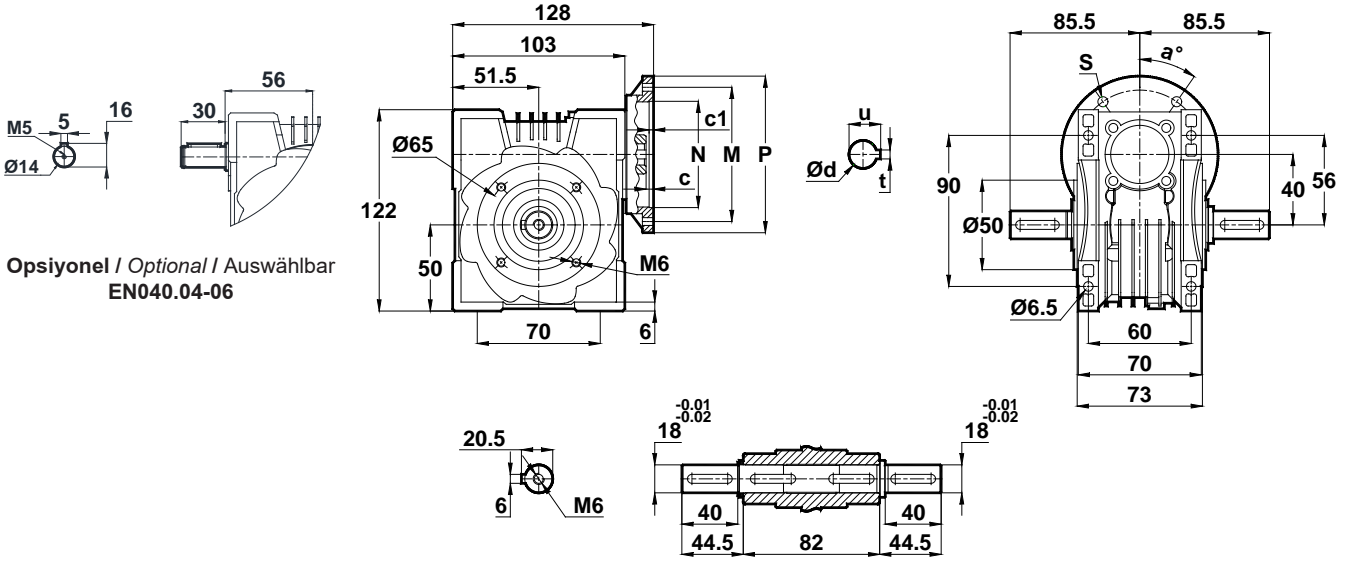

Opsiyonel / Optional / Auswählbar  
EN040.04-06

#### EN040.05

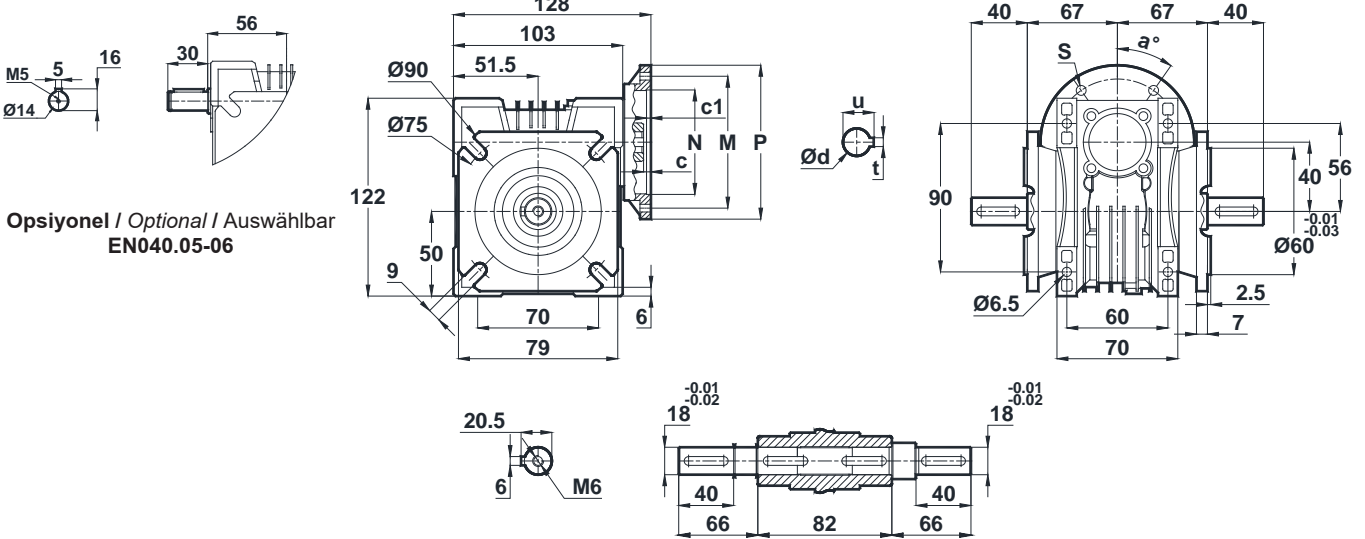

Opsiyonel / Optional / Auswählbar  
EN040.05-06

EN040	c	c1	N	M	P	d	u	t	a	s
63/B14	4	2.5	60	75	90	11	12.8	4	45°	5.5
71/B14	4	3	70	85	105	14	16.3	5	45°	10
63/B5	4	3.5	95	115	140	11	12.8	4	45°	10
71/B5	4	4	110	130	160	14	16.3	5	45°	10



# Ölçü Sayfaları

## Dimension Pages

### Abmessungsseiten



-Mil ucu çekirme deliği DIN 332 sayfa 2 / Tapped center hole to DIN 332, sheet 2 / Zentrierung mit Gewinde DIN 332, Blatt 2

#### EN040.08

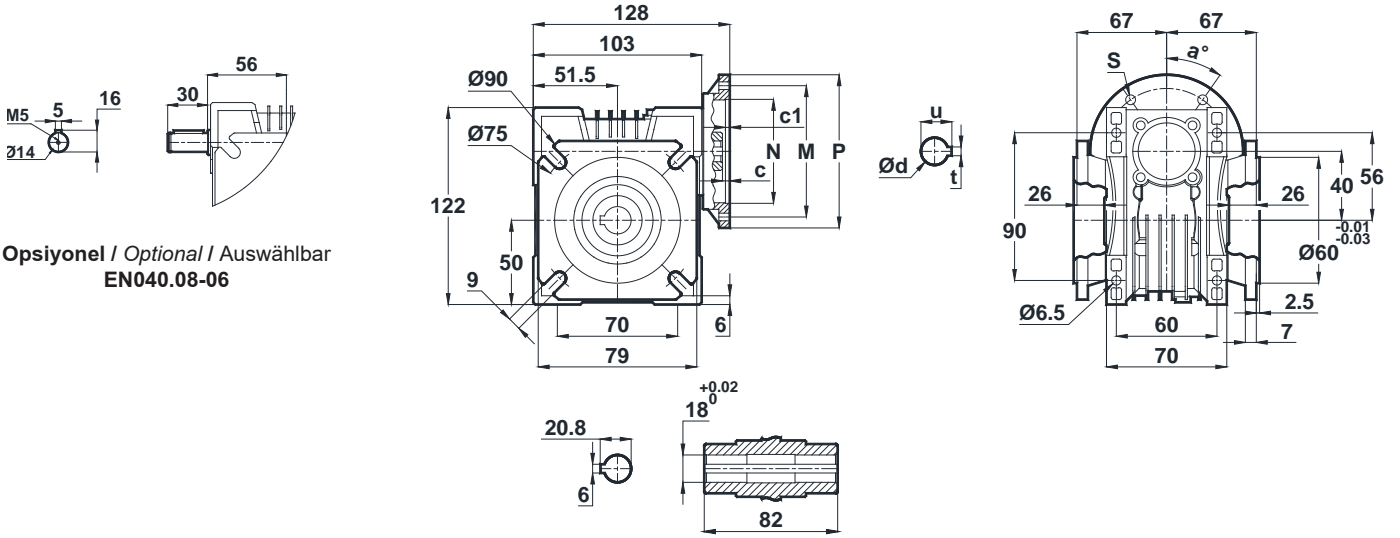

Opsiyonel / Optional / Auswählbar  
EN040.08-06

EN040	c	c1	N	M	P	d	u	t	a	s
63/B14	4	2.5	60	75	90	11	12.8	4	45°	5.5
71/B14	4	3	70	85	105	14	16.3	5	45°	10
63/B5	4	3.5	95	115	140	11	12.8	4	45°	10
71/B5	4	4	110	130	160	14	16.3	5	45°	10

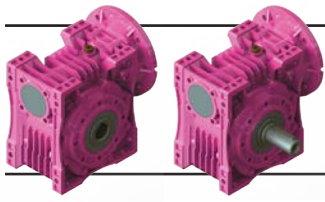

# Ölçü Sayfaları

## Dimension Pages

### Abmessungsseiten

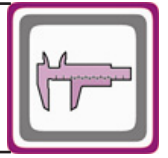

-Mil ucu çekirme deliği DIN 332 sayfa 2 / Tapped center hole to DIN 332, sheet 2 / Zentrierung mit Gewinde DIN 332, Blatt 2

#### EN050.00

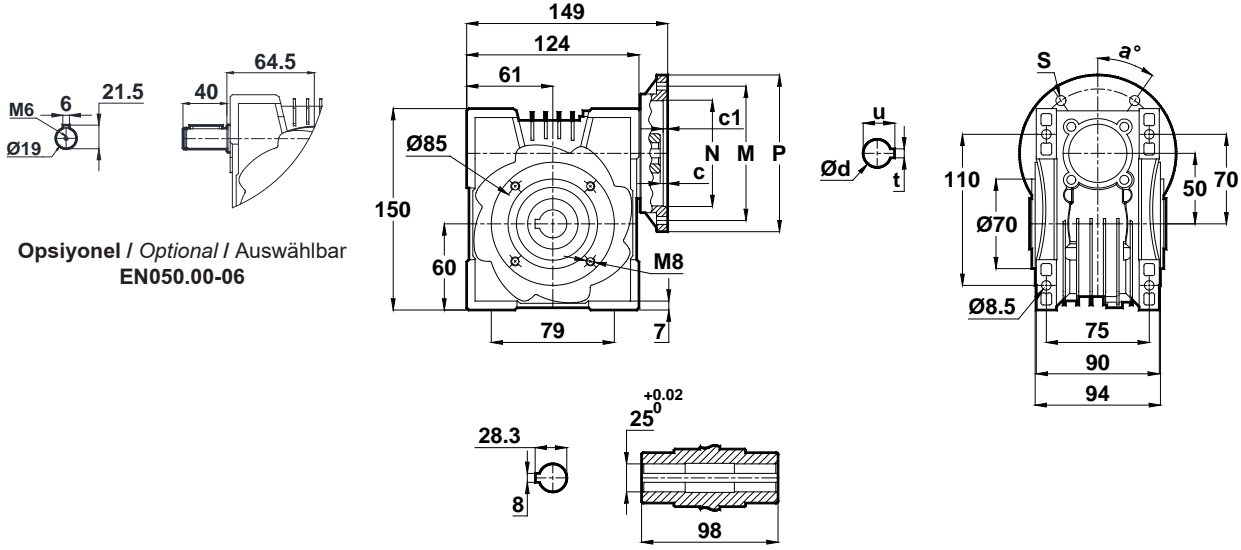

Opsiyonel / Optional / Auswählbar  
EN050.00-06

#### EN050.01

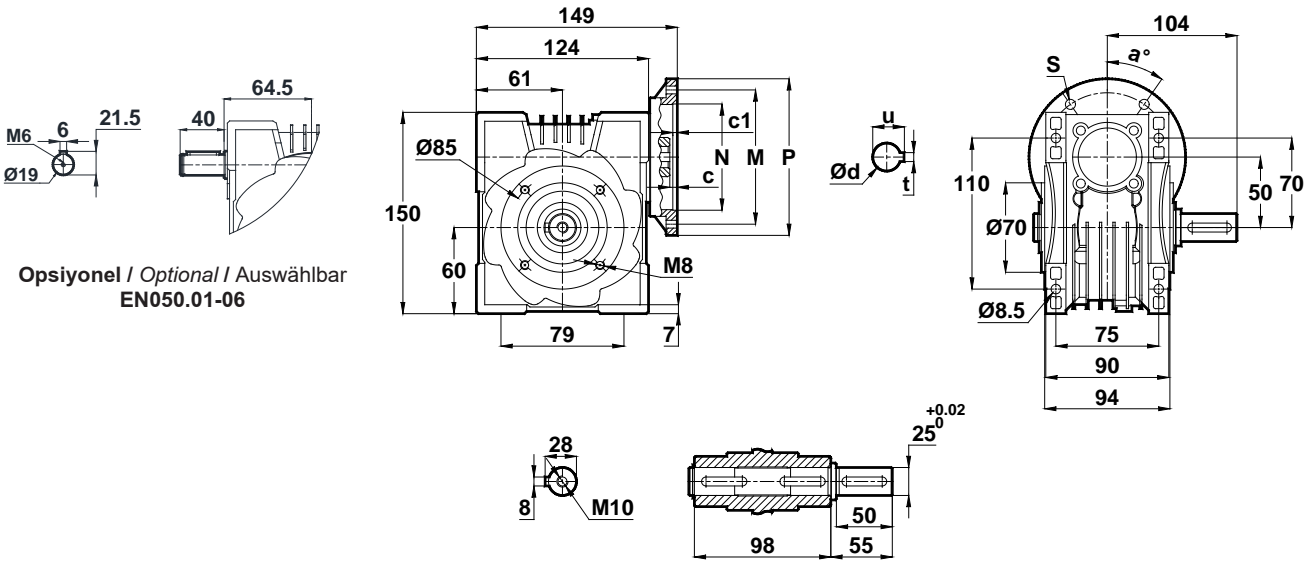

Opsiyonel / Optional / Auswählbar  
EN050.01-06

EN050	c	c1	N	M	P	d	u	t	a	s
71/B14	10.7	3	70	85	105	14	16.3	5	45°	7
80/B14	10.7	4	80	100	120	19	21.8	6	45°	7
90/B14	10.7	4	95	115	140	24	27.3	8	45°	9
63/B5	10.7	3.5	95	115	140	11	12.8	4	45°	10
71/B5	10.7	4	110	130	160	14	16.3	5	45°	10
80/B5	10.7	4	130	165	200	19	21.8	6	45°	12
90/B5	10.7	4	130	165	200	24	27.3	8	45°	12

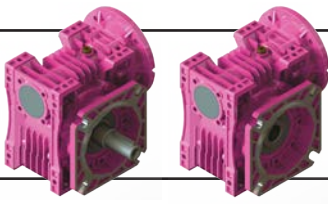

# Ölçü Sayfaları

## Dimension Pages

### Abmessungsseiten

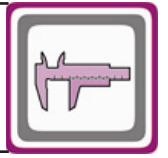

-Mil ucu çekirme deliği DIN 332 sayfa 2 / Tapped center hole to DIN 332, sheet 2 / Zentrierung mit Gewinde DIN 332, Blatt 2

#### EN050.02

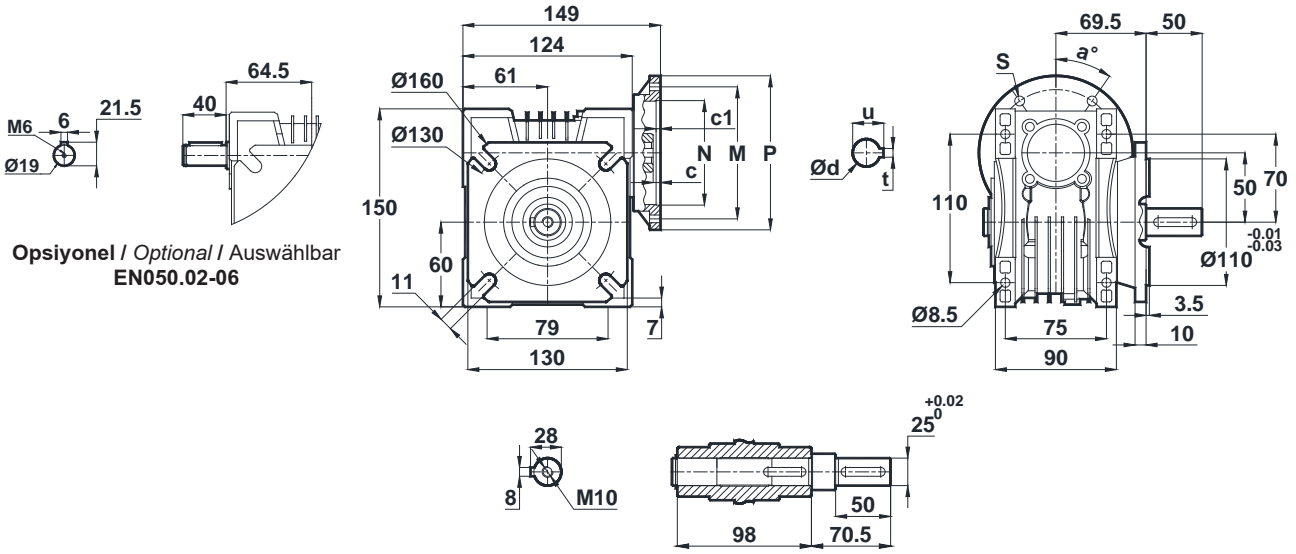

#### EN050.03

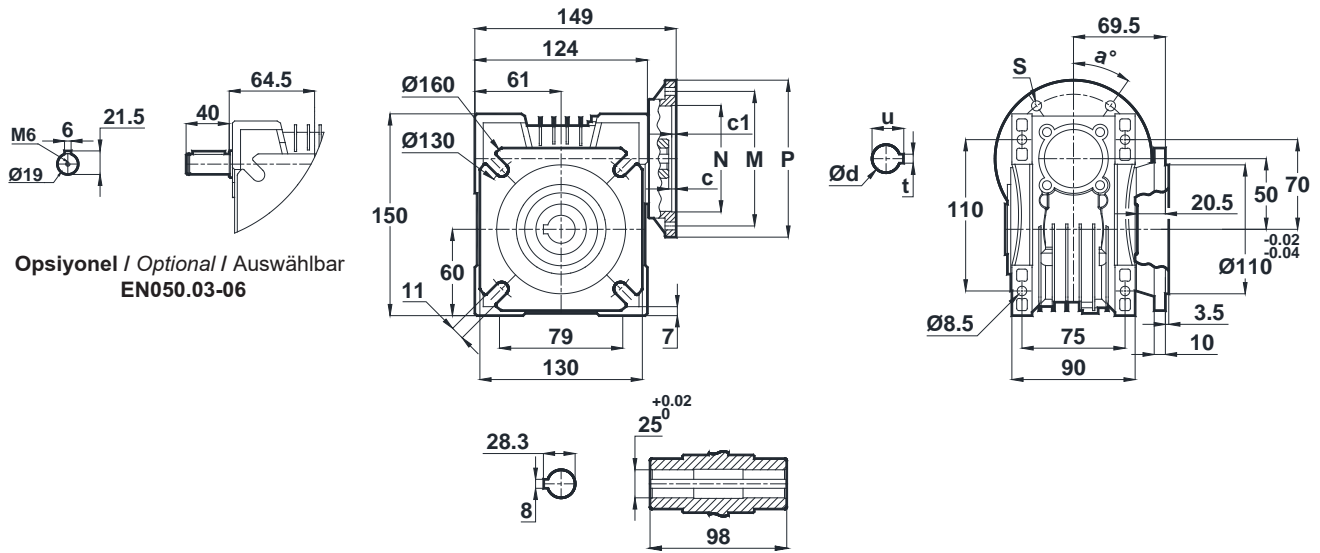

EN050	c	c1	N	M	P	d	u	t	a	s
71/B14	10.7	3	70	85	105	14	16.3	5	45°	7
80/B14	10.7	4	80	100	120	19	21.8	6	45°	7
90/B14	10.7	4	95	115	140	24	27.3	8	45°	9
63/B5	10.7	3.5	95	115	140	11	12.8	4	45°	10
71/B5	10.7	4	110	130	160	14	16.3	5	45°	10
80/B5	10.7	4	130	165	200	19	21.8	6	45°	12
90/B5	10.7	4	130	165	200	24	27.3	8	45°	12

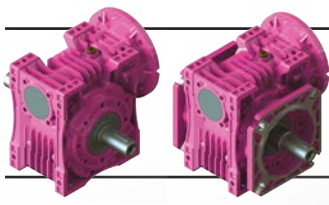

# Ölçü Sayfaları

## Dimension Pages

### Abmessungsseiten

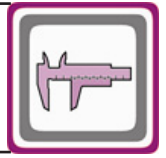

-Mil ucu çekirme deliği DIN 332 sayfa 2 / Tapped center hole to DIN 332, sheet 2 / Zentrierung mit Gewinde DIN 332, Blatt 2

#### EN050.04

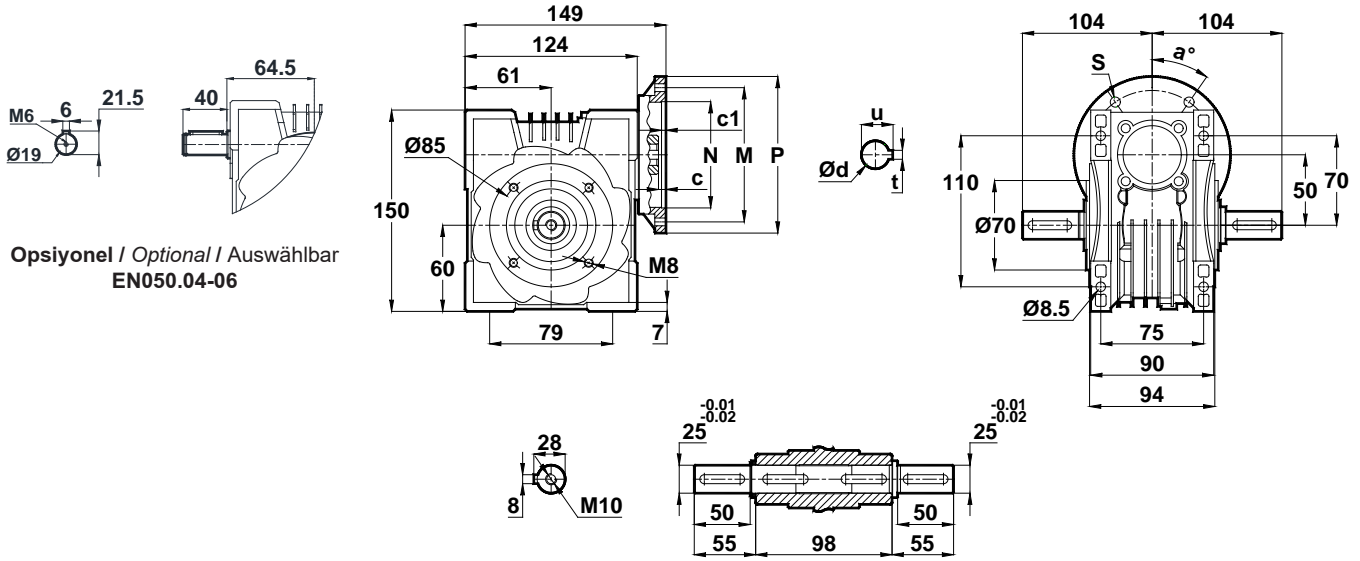

#### EN050.05

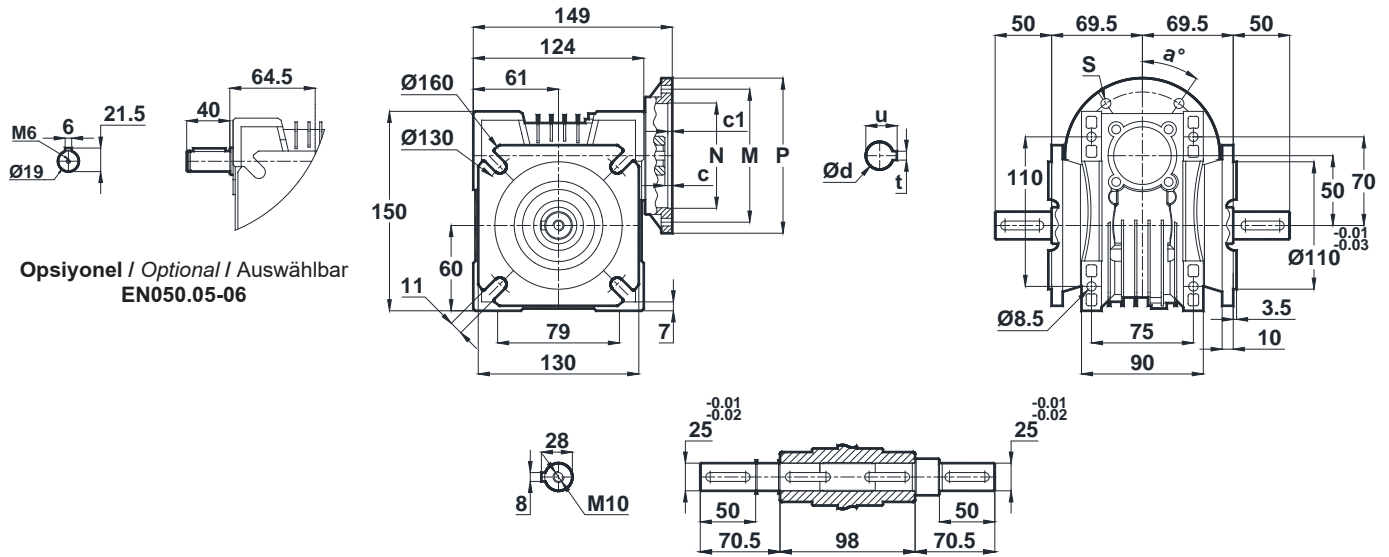

EN050	c	c1	N	M	P	d	u	t	a	s
71/B14	10.7	3	70	85	105	14	16.3	5	45°	7
80/B14	10.7	4	80	100	120	19	21.8	6	45°	7
90/B14	10.7	4	95	115	140	24	27.3	8	45°	9
63/B5	10.7	3.5	95	115	140	11	12.8	4	45°	10
71/B5	10.7	4	110	130	160	14	16.3	5	45°	10
80/B5	10.7	4	130	165	200	19	21.8	6	45°	12
90/B5	10.7	4	130	165	200	24	27.3	8	45°	12





# Ölçü Sayfaları

## Dimension Pages

### Abmessungsseiten

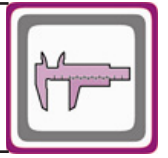

-Mil ucu çekirme deliği DIN 332 sayfa 2 / Tapped center hole to DIN 332, sheet 2 / Zentrierung mit Gewinde DIN 332, Blatt 2

#### EN050.08

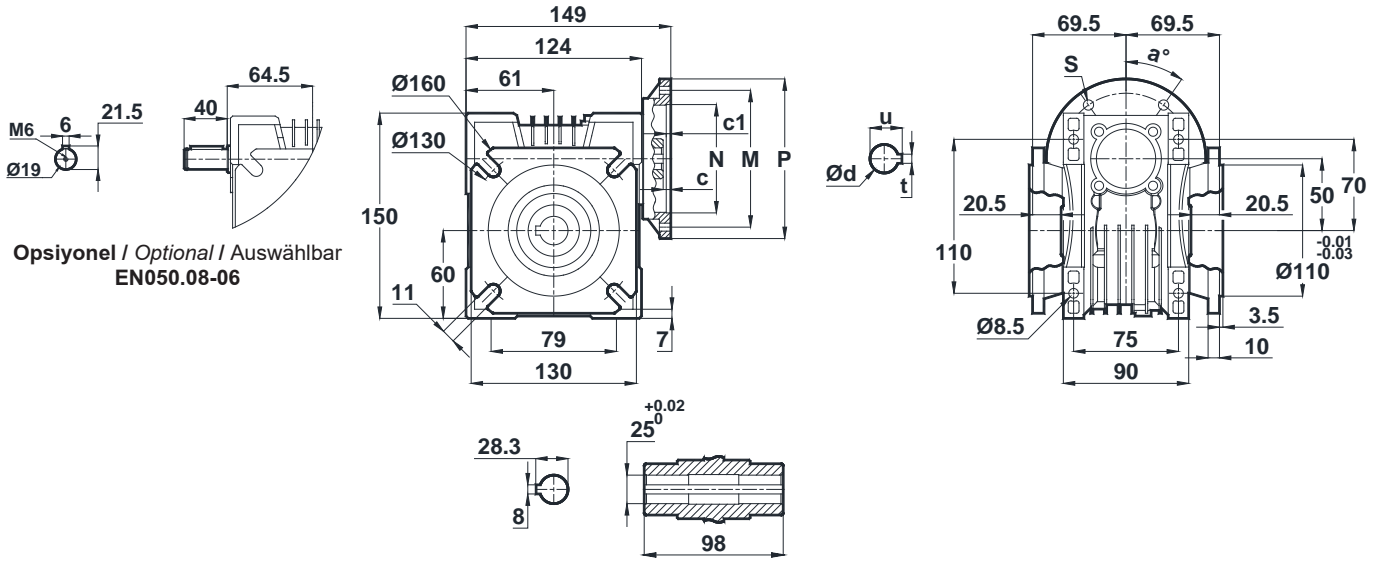

EN050	c	c1	N	M	P	d	u	t	a	s
71/B14	10.7	3	70	85	105	14	16.3	5	45°	7
80/B14	10.7	4	80	100	120	19	21.8	6	45°	7
90/B14	10.7	4	95	115	140	24	27.3	8	45°	9
63/B5	10.7	3.5	95	115	140	11	12.8	4	45°	10
71/B5	10.7	4	110	130	160	14	16.3	5	45°	10
80/B5	10.7	4	130	165	200	19	21.8	6	45°	12
90/B5	10.7	4	130	165	200	24	27.3	8	45°	12

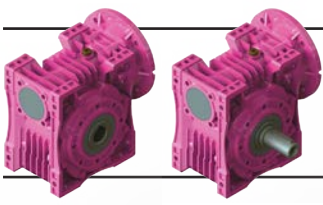

# Ölçü Sayfaları

## Dimension Pages

### Abmessungsseiten

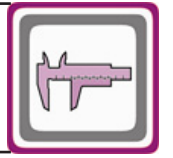

-Mil ucu çekirme deliği DIN 332 sayfa 2 / Tapped center hole to DIN 332, sheet 2 / Zentrierung mit Gewinde DIN 332, Blatt 2

#### EN063.00

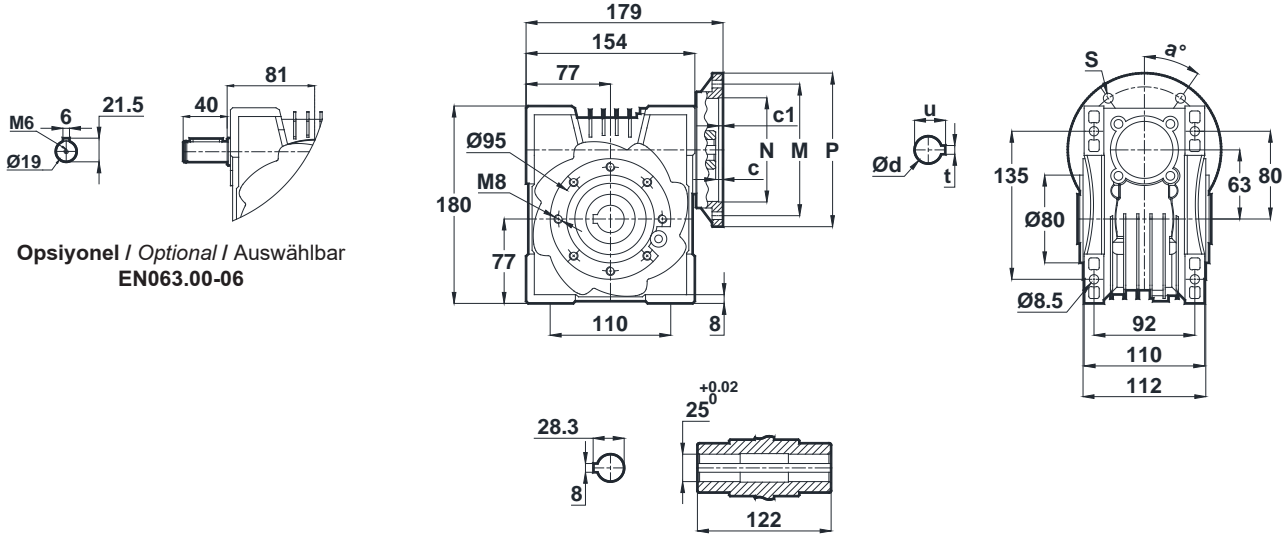

Opsiyonel / Optional / Auswählbar  
EN063.00-06

#### EN063.01

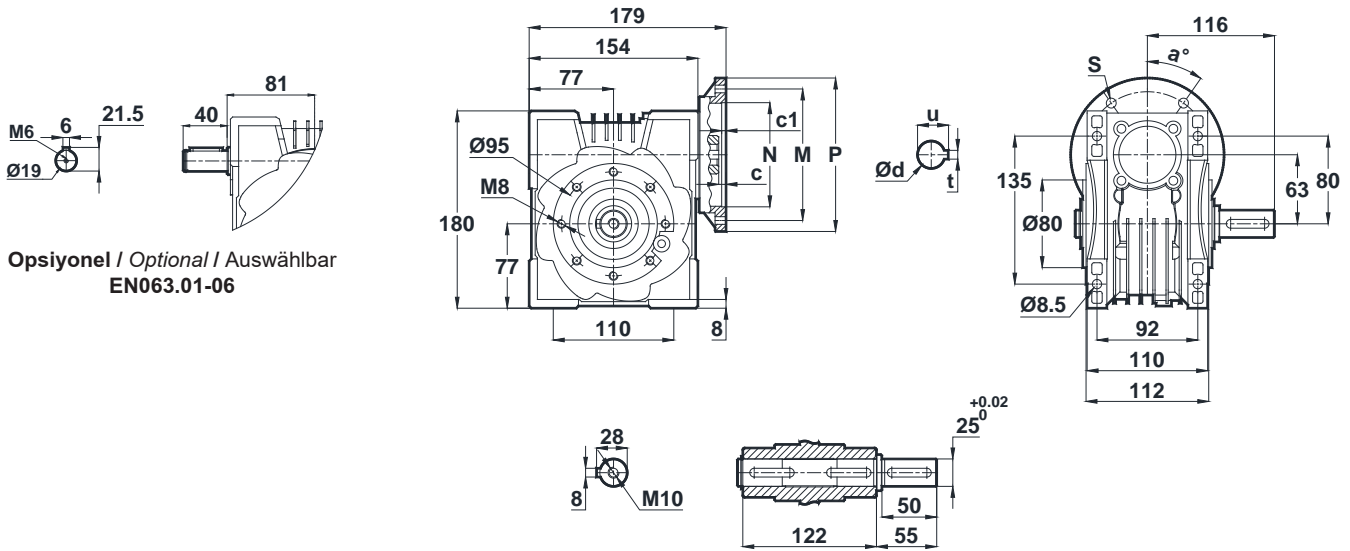

Opsiyonel / Optional / Auswählbar  
EN063.01-06

EN063	c	c1	N	M	P	d	u	t	a	s
71/B14	5.7	3	70	85	105	14	16.3	5	45°	7
80/B14	5.7	4	80	100	120	19	21.8	6	45°	7
90/B14	5.7	4	95	115	140	24	27.3	8	45°	9
71/B5	5.7	4	110	130	160	14	16.3	5	45°	10
80/B5	5.7	4	130	165	200	19	21.8	6	45°	12
90/B5	5.7	4	130	165	200	24	27.3	8	45°	12

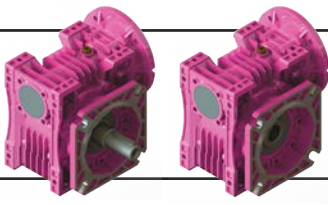

# Ölçü Sayfaları

## Dimension Pages

### Abmessungsseiten

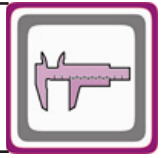

-Mil ucu çekirme deliği DIN 332 sayfa 2 / Tapped center hole to DIN 332, sheet 2 / Zentrierung mit Gewinde DIN 332, Blatt 2

#### EN063.02

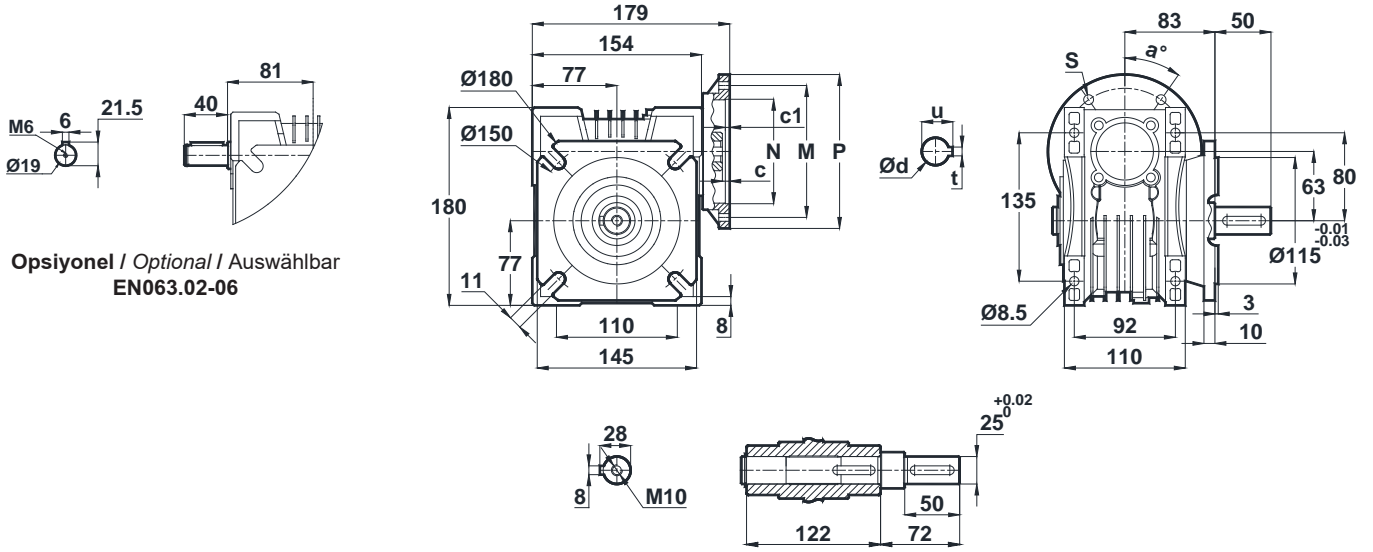

#### EN063.03

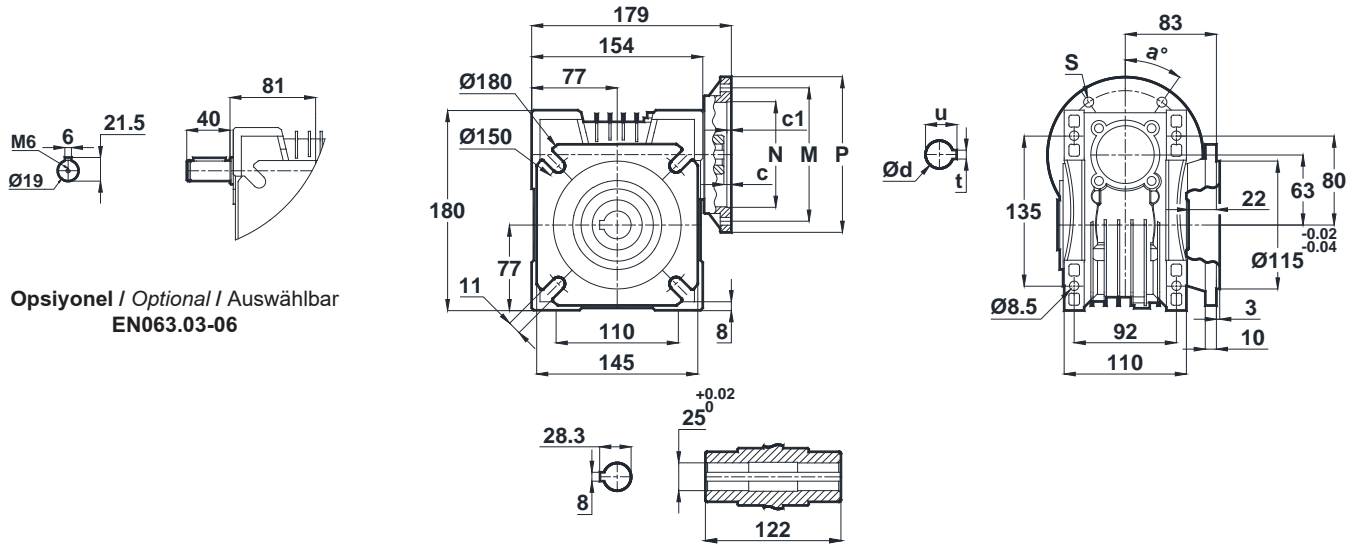

EN063	c	c1	N	M	P	d	u	t	a	s
71/B14	5.7	3	70	85	105	14	16.3	5	45°	7
80/B14	5.7	4	80	100	120	19	21.8	6	45°	7
90/B14	5.7	4	95	115	140	24	27.3	8	45°	9
71/B5	5.7	4	110	130	160	14	16.3	5	45°	10
80/B5	5.7	4	130	165	200	19	21.8	6	45°	12
90/B5	5.7	4	130	165	200	24	27.3	8	45°	12

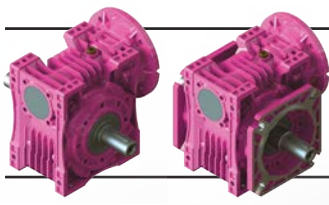

# Ölçü Sayfaları

## Dimension Pages

### Abmessungsseiten

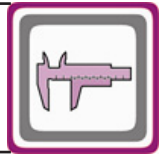

-Mil ucu çekirme deliği DIN 332 sayfa 2 / Tapped center hole to DIN 332, sheet 2 / Zentrierung mit Gewinde DIN 332, Blatt 2

#### EN063.04

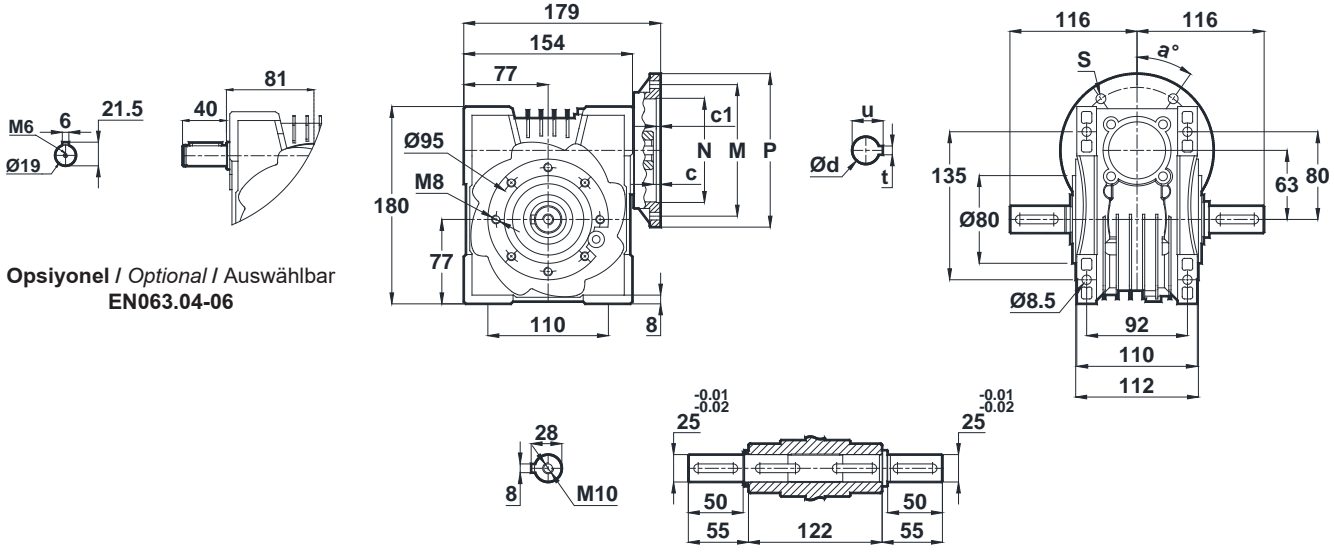

#### EN063.05

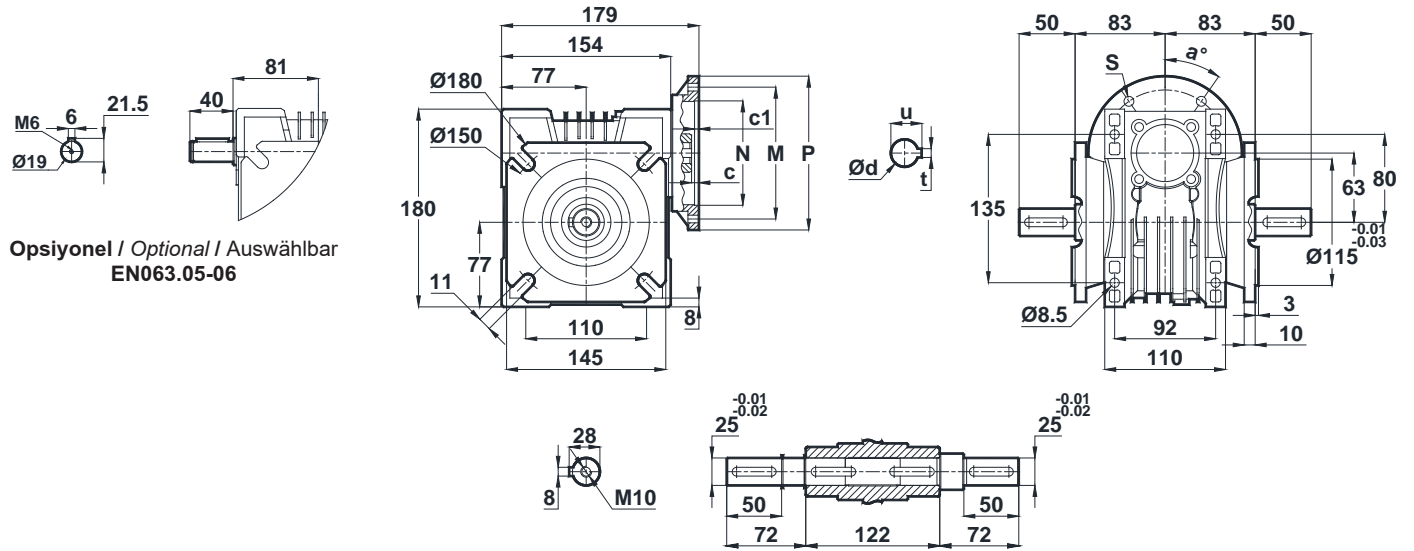

EN063	c	c1	N	M	P	d	u	t	a	s
71/B14	5.7	3	70	85	105	14	16.3	5	45°	7
80/B14	5.7	4	80	100	120	19	21.8	6	45°	7
90/B14	5.7	4	95	115	140	24	27.3	8	45°	9
71/B5	5.7	4	110	130	160	14	16.3	5	45°	10
80/B5	5.7	4	130	165	200	19	21.8	6	45°	12
90/B5	5.7	4	130	165	200	24	27.3	8	45°	12



# Ölçü Sayfaları

## Dimension Pages

### Abmessungsseiten



-Mil ucu çekirme deliği DIN 332 sayfa 2 / Tapped center hole to DIN 332, sheet 2 / Zentrierung mit Gewinde DIN 332, Blatt 2

#### EN063.08

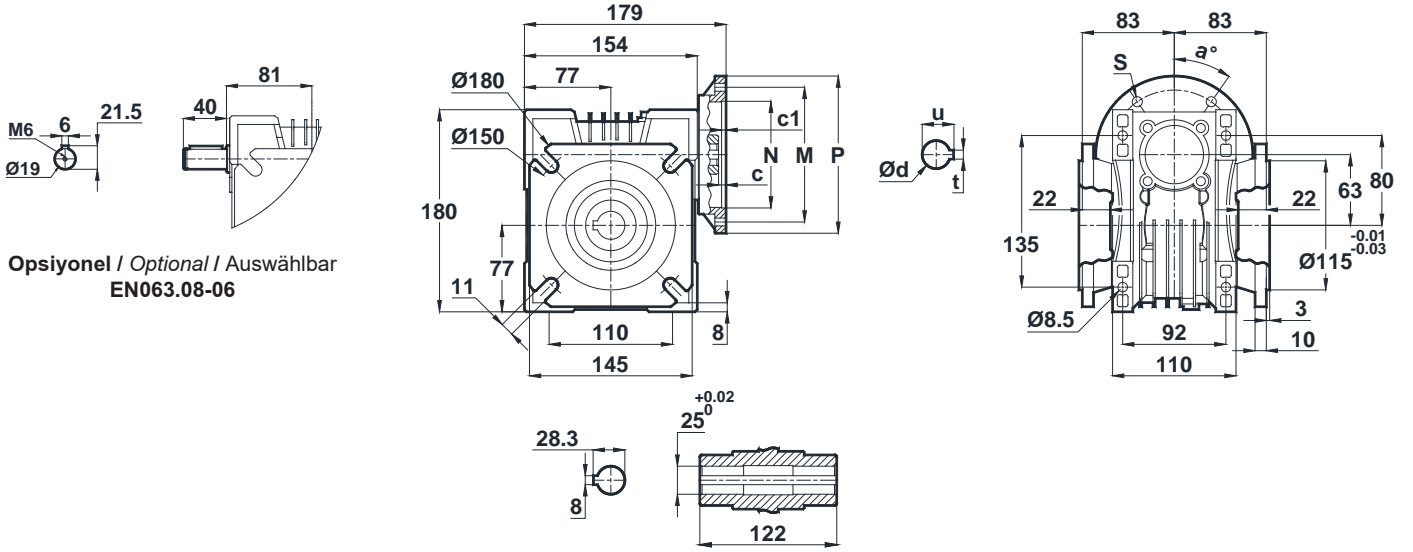

Opsiyonel / Optional / Auswählbar  
EN063.08-06

EN063	c	c1	N	M	P	d	u	t	a	s
71/B14	5.7	3	70	85	105	14	16.3	5	45°	7
80/B14	5.7	4	80	100	120	19	21.8	6	45°	7
90/B14	5.7	4	95	115	140	24	27.3	8	45°	9
71/B5	5.7	4	110	130	160	14	16.3	5	45°	10
80/B5	5.7	4	130	165	200	19	21.8	6	45°	12
90/B5	5.7	4	130	165	200	24	27.3	8	45°	12

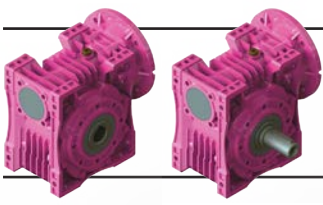

# Ölçü Sayfaları

## Dimension Pages

### Abmessungsseiten

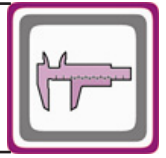

-Mil ucu çekirme deliği DIN 332 sayfa 2 / Tapped center hole to DIN 332, sheet 2 / Zentrierung mit Gewinde DIN 332, Blatt 2

#### EN075.00

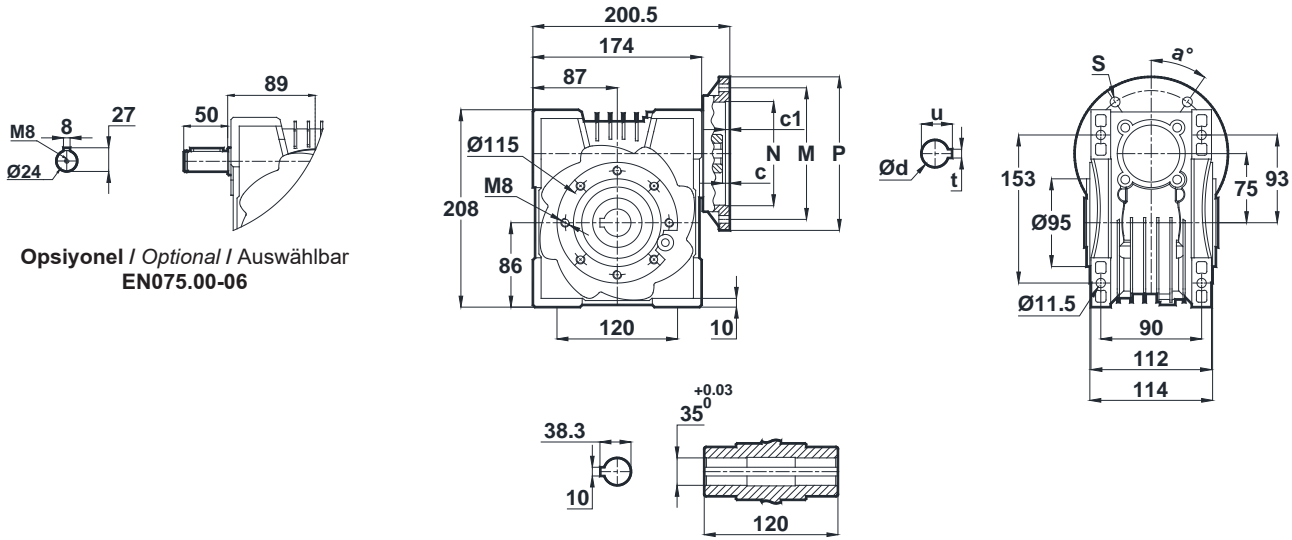

Opsiyonel / Optional / Auswählbar  
EN075.00-06

#### EN075.01

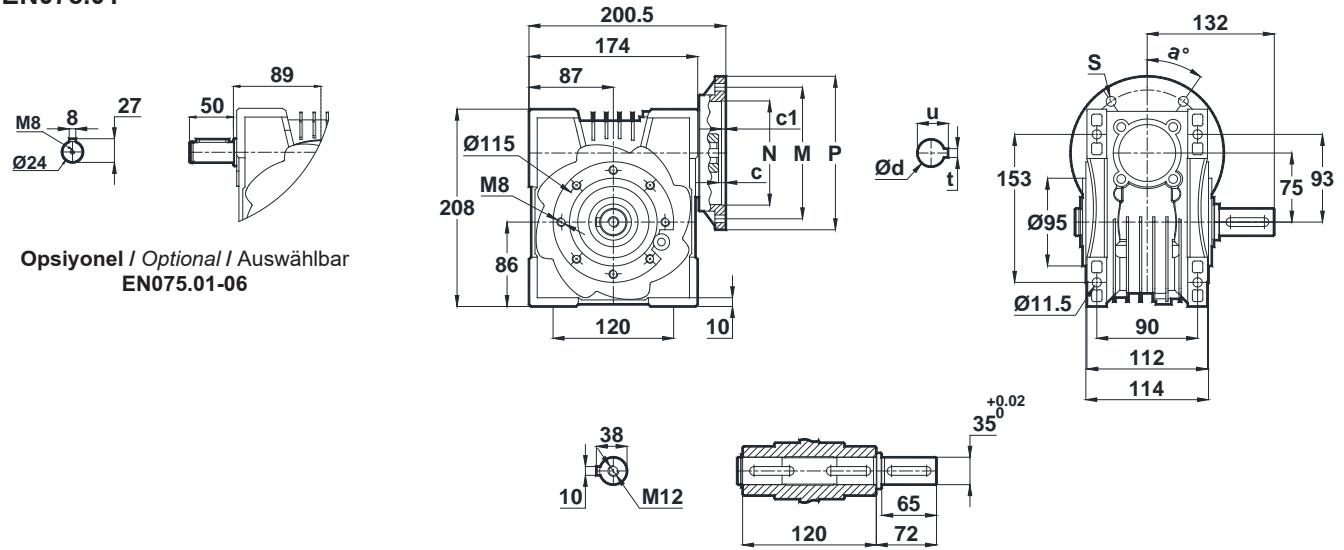

Opsiyonel / Optional / Auswählbar  
EN075.01-06

EN075	c	c1	N	M	P	d	u	t	a	s
80/B14	10.5	4	80	100	120	19	21.8	6	45°	7
90/B14	10.5	4	95	115	140	24	27.3	8	45°	9
100-112/B14	10.5	3.5	110	130	160	28	31.3	8	45°	9
80/B5	10.5	4	130	165	200	19	21.8	6	45°	12
90/B5	10.5	4	130	165	200	24	27.3	8	45°	12
100-112/B5	10.5	4.5	180	215	250	28	31.3	8	45°	13

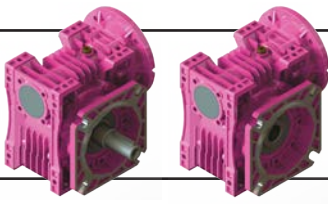

# Ölçü Sayfaları

## Dimension Pages

### Abmessungsseiten

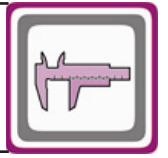

-Mil ucu çekirme deliği DIN 332 sayfa 2 / Tapped center hole to DIN 332, sheet 2 / Zentrierung mit Gewinde DIN 332, Blatt 2

#### EN075.02

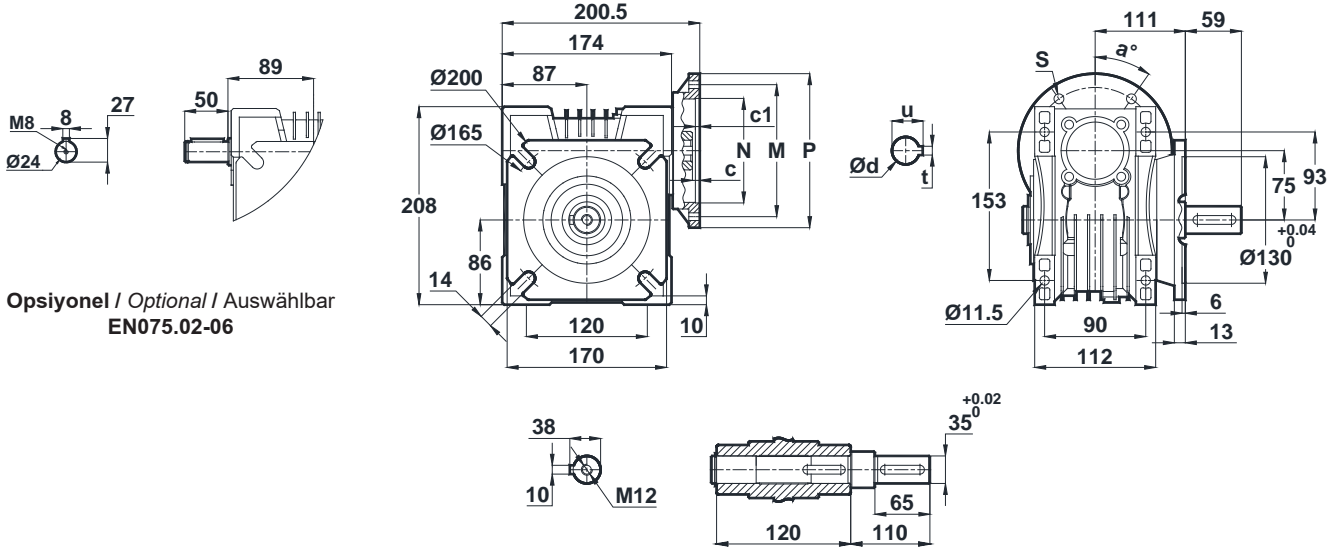

#### EN075.03

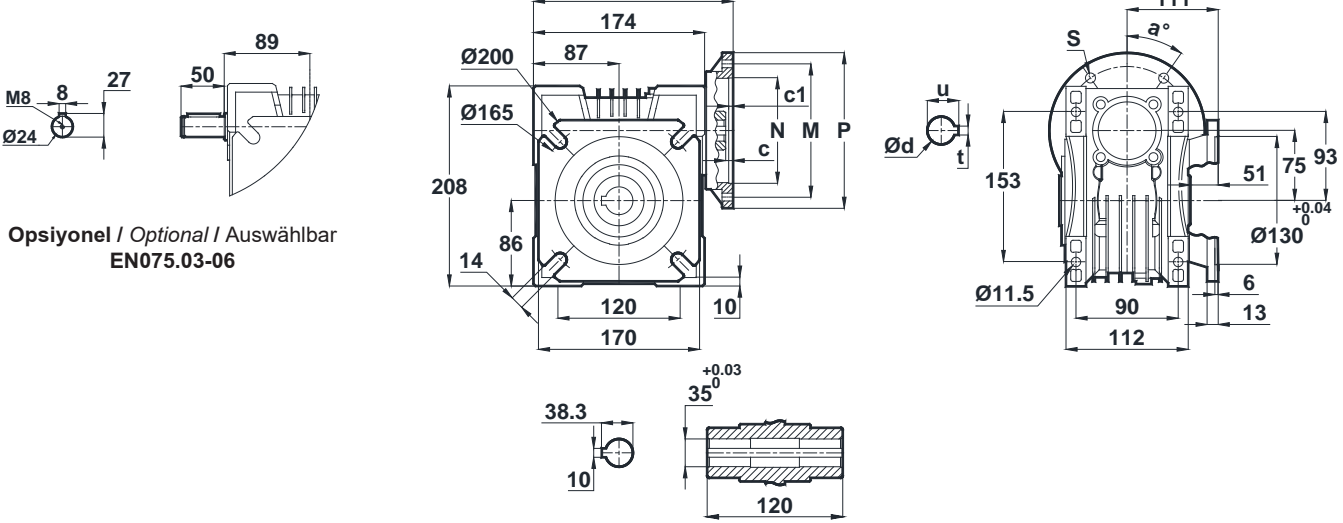

EN075	c	c1	N	M	P	d	u	t	a	s
80/B14	10.5	4	80	100	120	19	21.8	6	45°	7
90/B14	10.5	4	95	115	140	24	27.3	8	45°	9
100-112/B14	10.5	3.5	110	130	160	28	31.3	8	45°	9
80/B5	10.5	4	130	165	200	19	21.8	6	45°	12
90/B5	10.5	4	130	165	200	24	27.3	8	45°	12
100-112/B5	10.5	4.5	180	215	250	28	31.3	8	45°	13

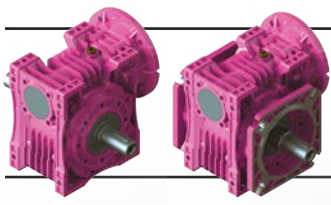

# Ölçü Sayfaları

## Dimension Pages

### Abmessungsseiten

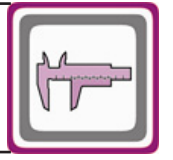

-Mil ucu çekirme deliği DIN 332 sayfa 2 / Tapped center hole to DIN 332, sheet 2 / Zentrierung mit Gewinde DIN 332, Blatt 2

#### EN075.04

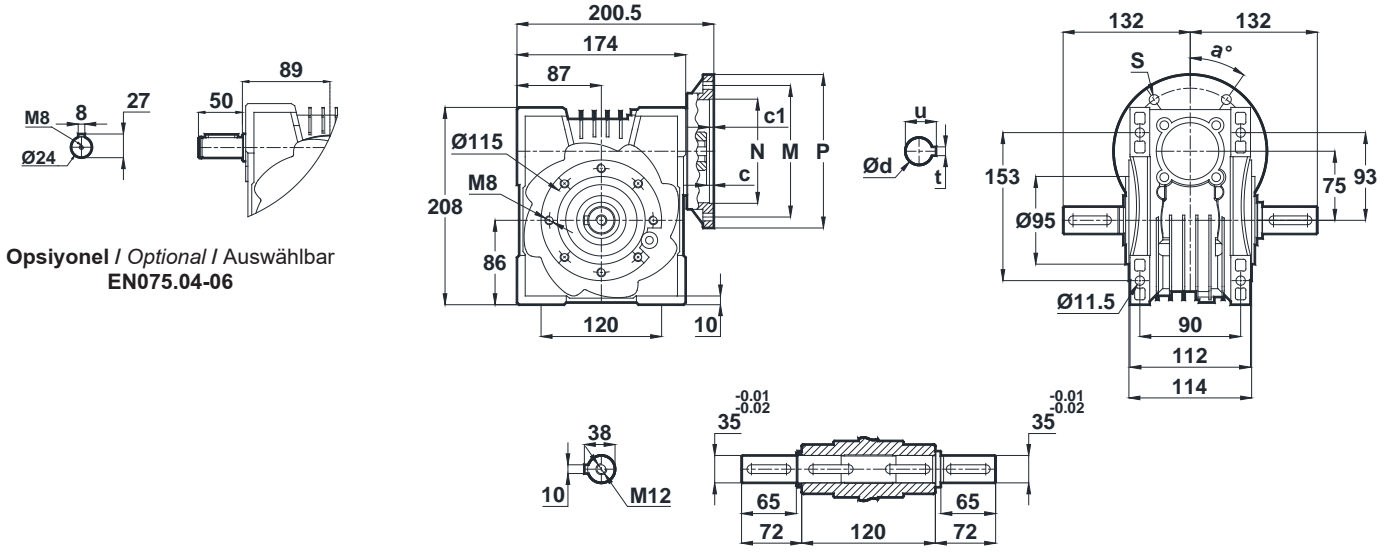

Opsiyonel / Optional / Auswählbar  
EN075.04-06

#### EN075.05

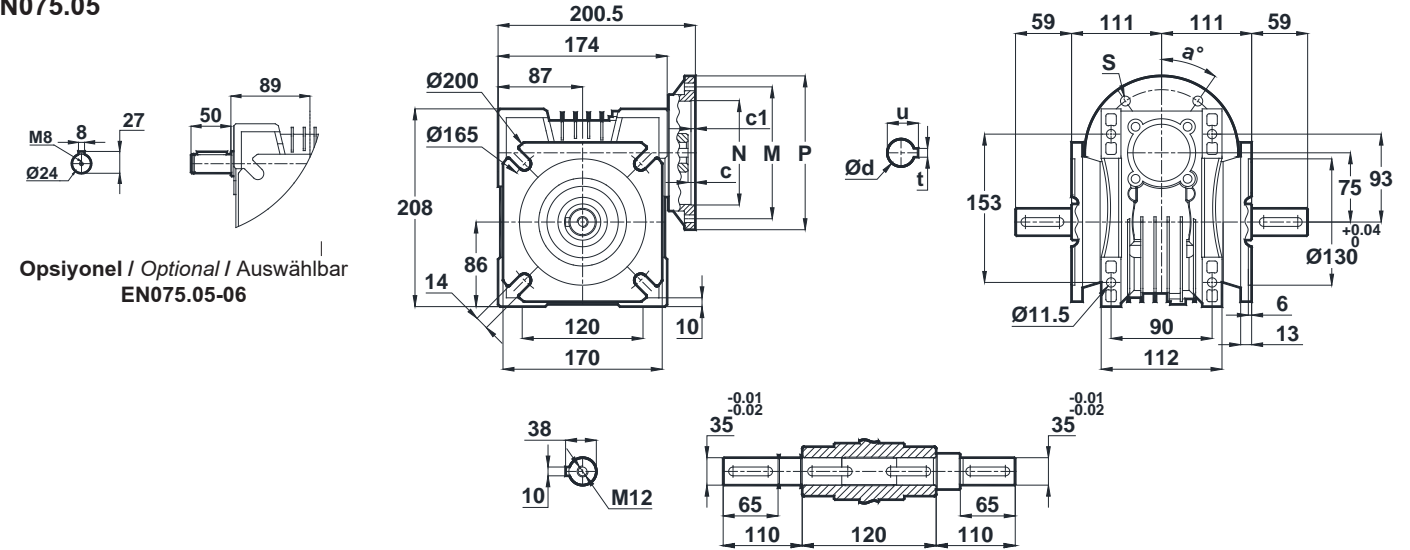

Opsiyonel / Optional / Auswählbar  
EN075.05-06

EN075	c	c1	N	M	P	d	u	t	a	s
80/B14	10.5	4	80	100	120	19	21.8	6	45°	7
90/B14	10.5	4	95	115	140	24	27.3	8	45°	9
100-112/B14	10.5	3.5	110	130	160	28	31.3	8	45°	9
80/B5	10.5	4	130	165	200	19	21.8	6	45°	12
90/B5	10.5	4	130	165	200	24	27.3	8	45°	12
100-112/B5	10.5	4.5	180	215	250	28	31.3	8	45°	13





# Ölçü Sayfaları Dimension Pages Abmessungsseiten

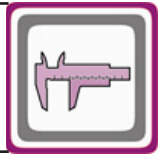

-Mil ucu çekirme deliği DIN 332 sayfa 2 / Tapped center hole to DIN 332, sheet 2 / Zentrierung mit Gewinde DIN 332, Blatt 2

## EN075.08

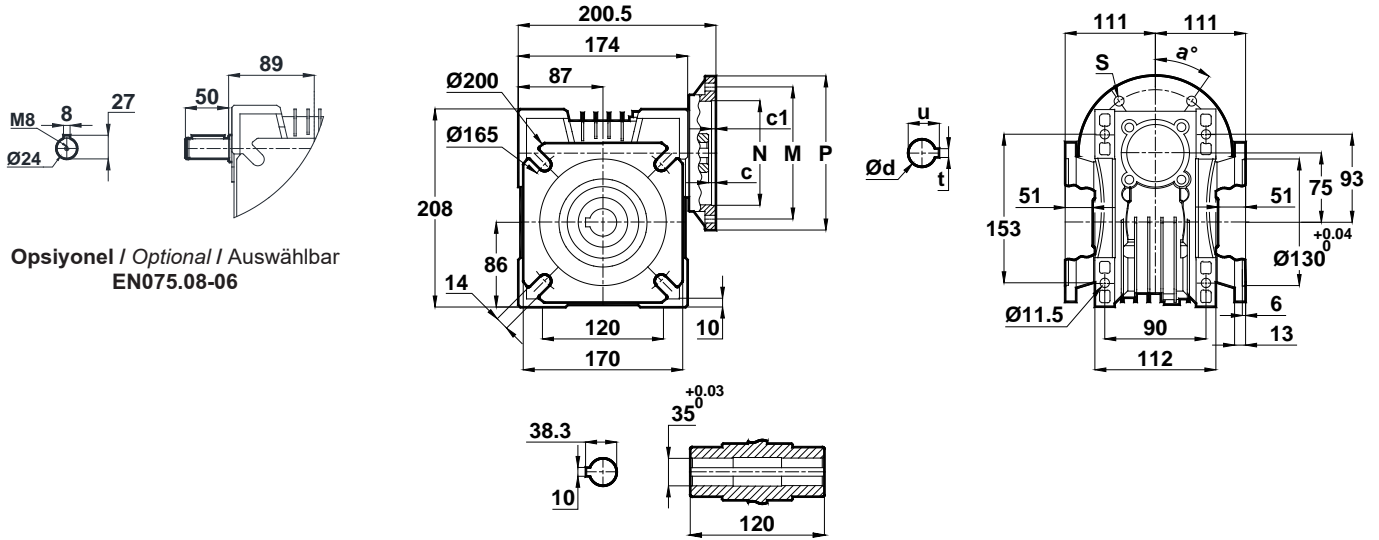

Opsiyonel / Optional / Auswählbar  
EN075.08-06

EN075	c	c1	N	M	P	d	u	t	a	s
80/B14	10.5	4	80	100	120	19	21.8	6	45°	7
90/B14	10.5	4	95	115	140	24	27.3	8	45°	9
100-112/B14	10.5	3.5	110	130	160	28	31.3	8	45°	9
80/B5	10.5	4	130	165	200	19	21.8	6	45°	12
90/B5	10.5	4	130	165	200	24	27.3	8	45°	12
100-112/B5	10.5	4.5	180	215	250	28	31.3	8	45°	13

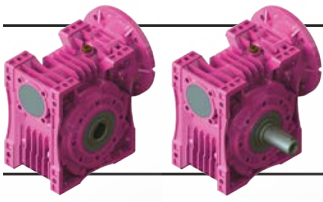

# Ölçü Sayfaları

## Dimension Pages

### Abmessungsseiten

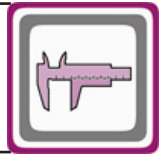

-Mil ucu çekirme deliği DIN 332 sayfa 2 / Tapped center hole to DIN 332, sheet 2 / Zentrierung mit Gewinde DIN 332, Blatt 2

#### EN080.00

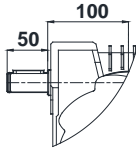
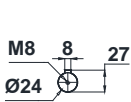

Opsiyonel / Optional / Auswählbar  
EN080.00-06

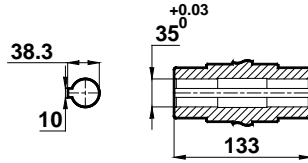
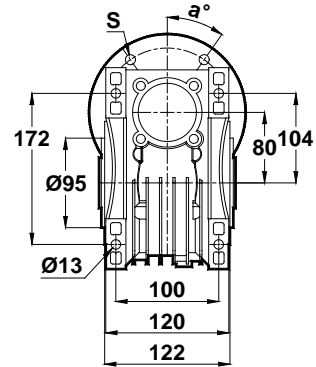
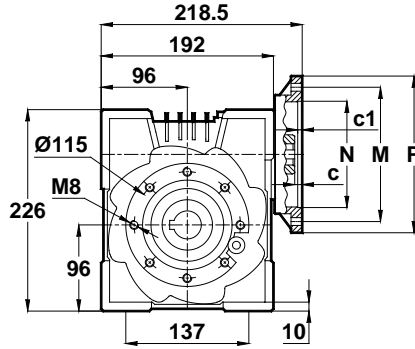

#### EN080.01

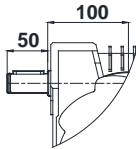
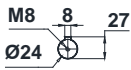

Opsiyonel / Optional / Auswählbar  
EN080.01-06

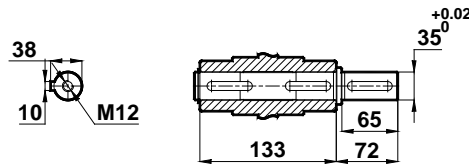
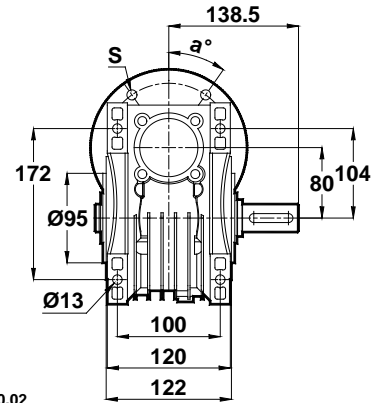
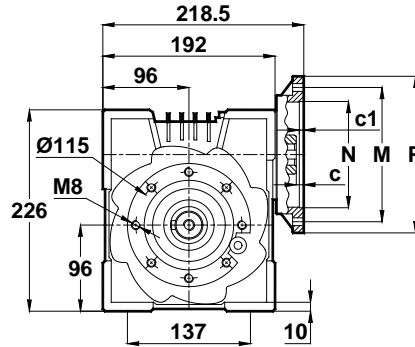

EN080	c	c1	N	M	P	d	u	t	a	s
80/B14	5.5	4	80	100	120	19	21.8	6	45°	7
90/B14	5.5	4	95	115	140	24	27.3	8	45°	9
100-112/B14	5.5	3.5	110	130	160	28	31.3	8	45°	9
80/B5	5.5	4	130	165	200	19	21.8	6	45°	13
90/B5	5.5	4	130	165	200	24	27.3	8	45°	13
100-112/B5	5.5	4.5	180	215	250	28	31.3	8	45°	13

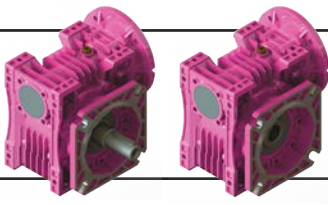

# Ölçü Sayfaları

## Dimension Pages

### Abmessungsseiten

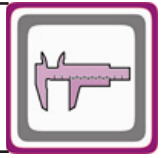

-Mil ucu çekirme deliği DIN 332 sayfa 2 / Tapped center hole to DIN 332, sheet 2 / Zentrierung mit Gewinde DIN 332, Blatt 2

#### EN080.02

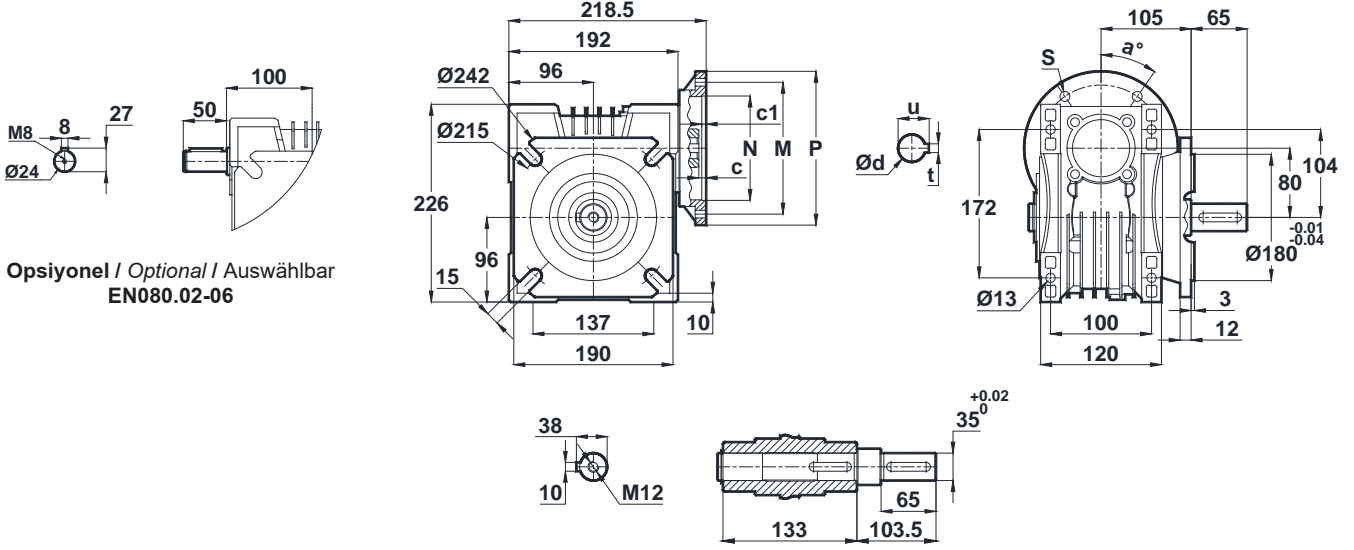

Opsiyonel / Optional / Auswählbar  
EN080.02-06

#### EN080.03

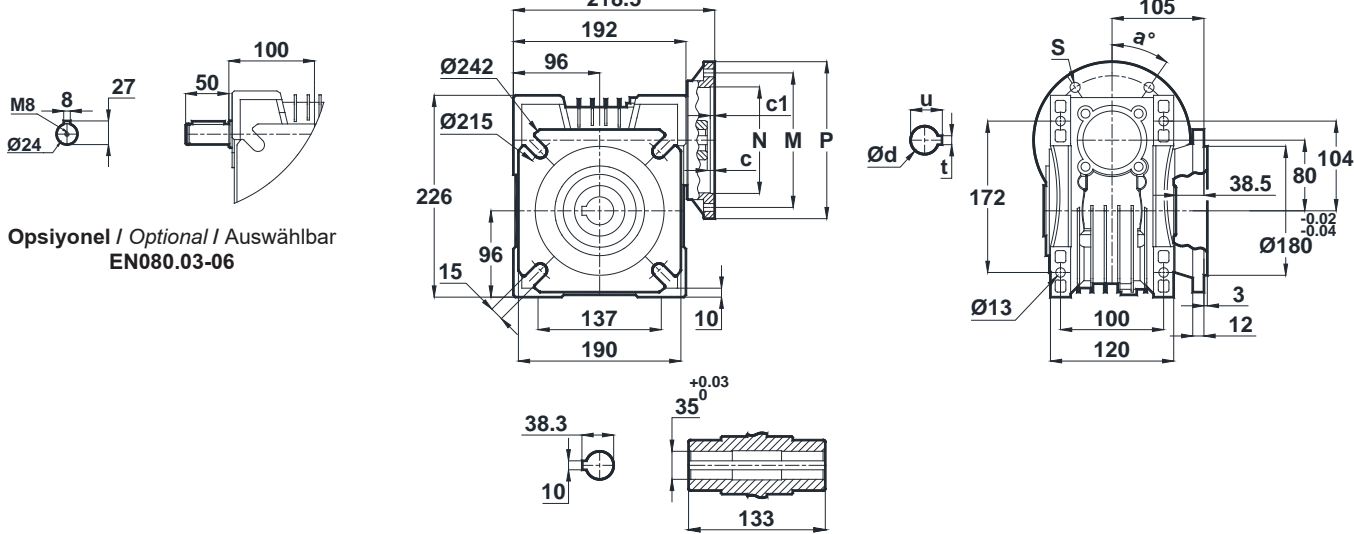

Opsiyonel / Optional / Auswählbar  
EN080.03-06

EN080	c	c1	N	M	P	d	u	t	a	s
80/B14	5.5	4	80	100	120	19	21.8	6	45°	7
90/B14	5.5	4	95	115	140	24	27.3	8	45°	9
100-112/B14	5.5	3.5	110	130	160	28	31.3	8	45°	9
80/B5	5.5	4	130	165	200	19	21.8	6	45°	13
90/B5	5.5	4	130	165	200	24	27.3	8	45°	13
100-112/B5	5.5	4.5	180	215	250	28	31.3	8	45°	13

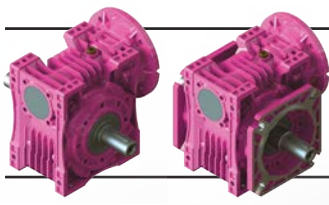

# Ölçü Sayfaları

## Dimension Pages

### Abmessungsseiten

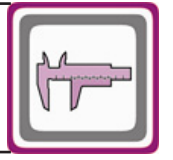

-Mil ucu çekirme deliği DIN 332 sayfa 2 / Tapped center hole to DIN 332, sheet 2 / Zentrierung mit Gewinde DIN 332, Blatt 2

#### EN080.04

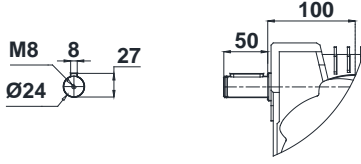

Opsiyonel / Optional / Auswählbar  
EN080.04-06

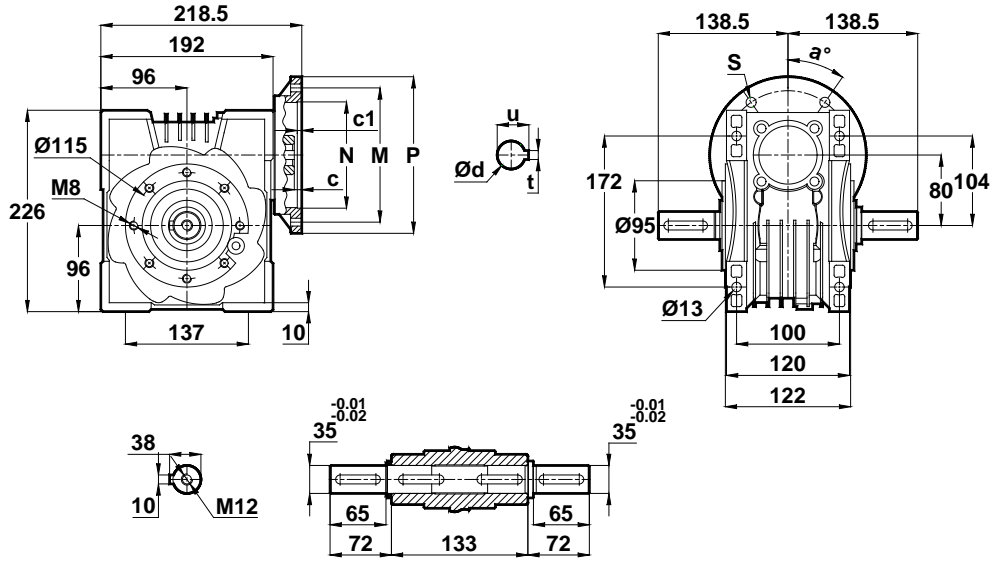

#### EN080.05

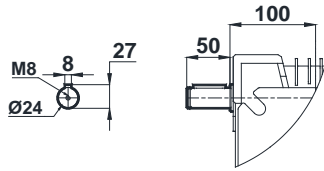

Opsiyonel / Optional / Auswählbar  
EN080.05-06

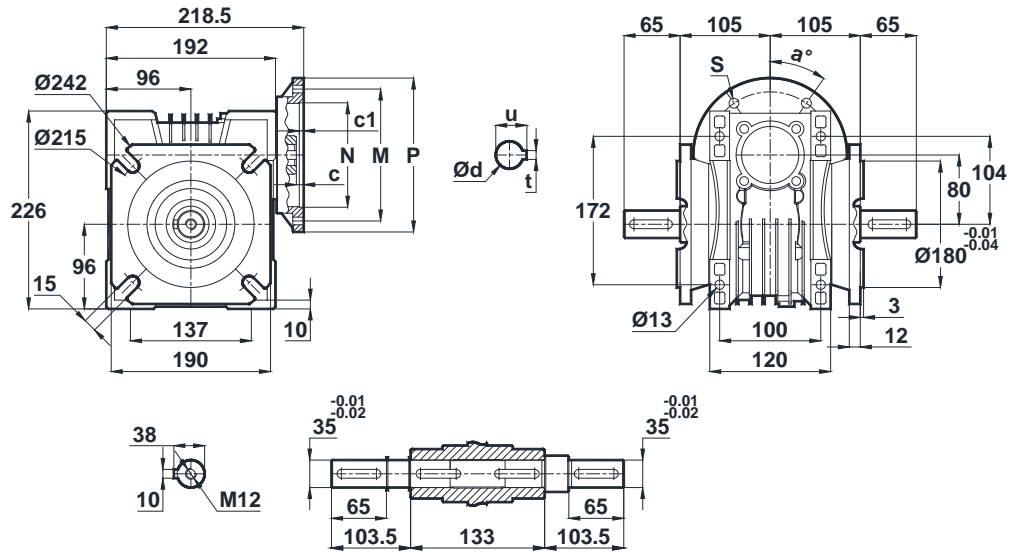

EN080	c	c1	N	M	P	d	u	t	a	s
80/B14	5.5	4	80	100	120	19	21.8	6	45°	7
90/B14	5.5	4	95	115	140	24	27.3	8	45°	9
100-112/B14	5.5	3.5	110	130	160	28	31.3	8	45°	9
80/B5	5.5	4	130	165	200	19	21.8	6	45°	12
90/B5	5.5	4	130	165	200	24	27.3	8	45°	12
100-112/B5	5.5	4.5	180	215	250	28	31.3	8	45°	13



# Ölçü Sayfaları Dimension Pages Abmessungsseiten



-Mil ucu çekirme deliği DIN 332 sayfa 2 / Tapped center hole to DIN 332, sheet 2 / Zentrierung mit Gewinde DIN 332, Blatt 2

## EN080.08

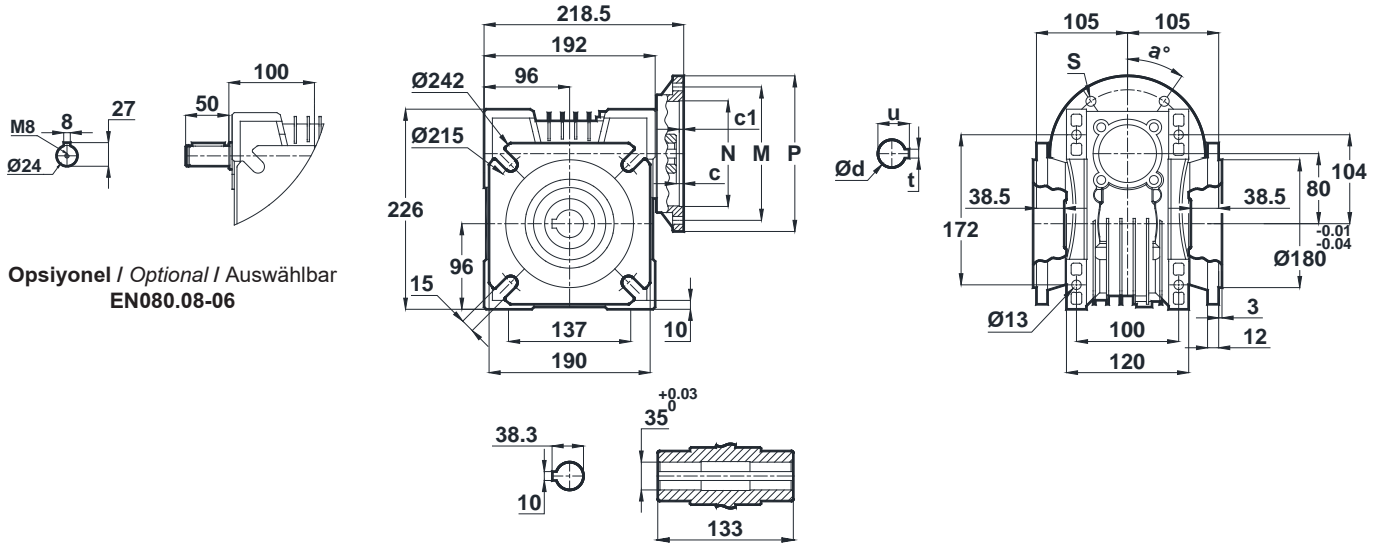

Opsiyonel / Optional / Auswählbar  
EN080.08-06

EN080	c	c1	N	M	P	d	u	t	a	s
80/B14	5.5	4	80	100	120	19	21.8	6	45°	7
90/B14	5.5	4	95	115	140	24	27.3	8	45°	9
100-112/B14	5.5	3.5	110	130	160	28	31.3	8	45°	9
80/B5	5.5	4	130	165	200	19	21.8	6	45°	12
90/B5	5.5	4	130	165	200	24	27.3	8	45°	12
100-112/B5	5.5	4.5	180	215	250	28	31.3	8	45°	13

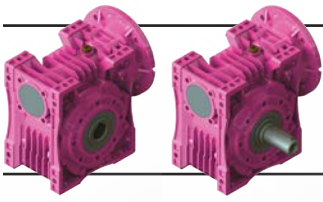

# Ölçü Sayfaları

## Dimension Pages

### Abmessungsseiten

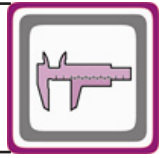

-Mil ucu çekirme deliği DIN 332 sayfa 2 / Tapped center hole to DIN 332, sheet 2 / Zentrierung mit Gewinde DIN 332, Blatt 2

#### EN100.00

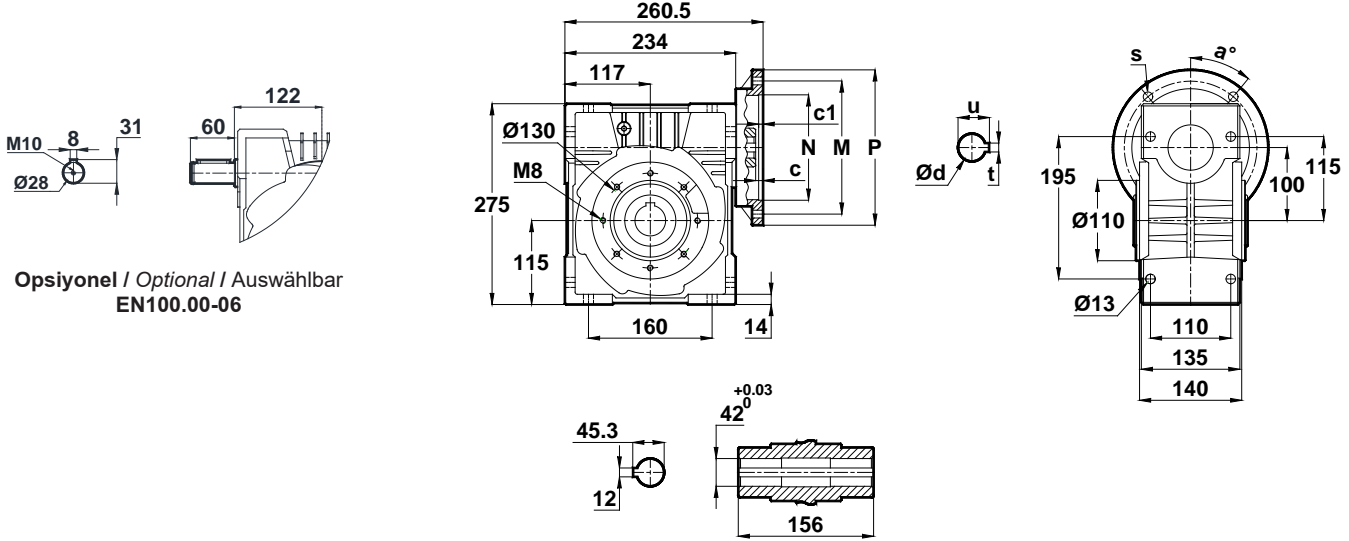

Opsiyonel / Optional / Auswählbar  
EN100.00-06

#### EN100.01

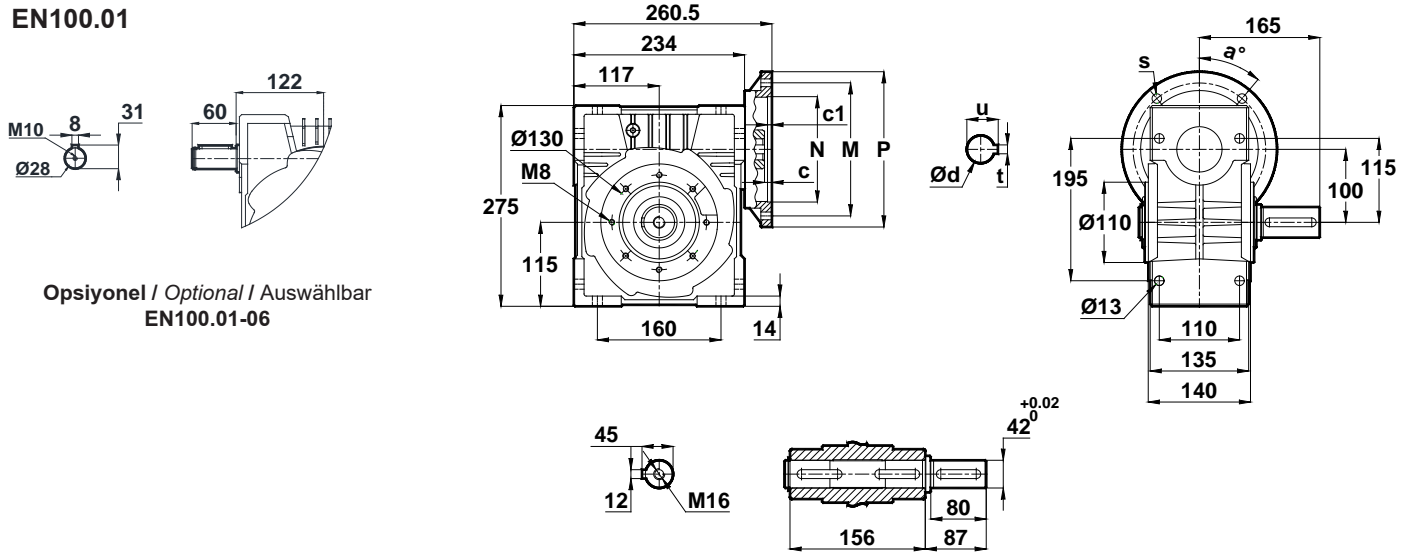

Opsiyonel / Optional / Auswählbar  
EN100.01-06

EN100	c	c1	N	M	P	d	u	t	a	s
80/B14	5.5	4	80	100	120	19	21.8	6	45°	7
90/B14	5.5	4	95	115	140	24	27.3	8	45°	9
100-112/B14	5.5	3.5	110	130	160	28	31.3	8	45°	9
80/B5	5.5	4	130	165	200	19	21.8	6	45°	12
90/B5	5.5	4	130	165	200	24	27.3	8	45°	12
100-112/B5	5.5	4.5	180	215	250	28	31.3	8	45°	13

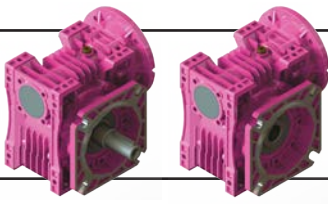

# Ölçü Sayfaları

## Dimension Pages

### Abmessungsseiten

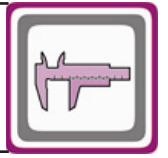

-Mil ucu çekirme deliği DIN 332 sayfa 2 / Tapped center hole to DIN 332, sheet 2 / Zentrierung mit Gewinde DIN 332, Blatt 2

#### EN100.02

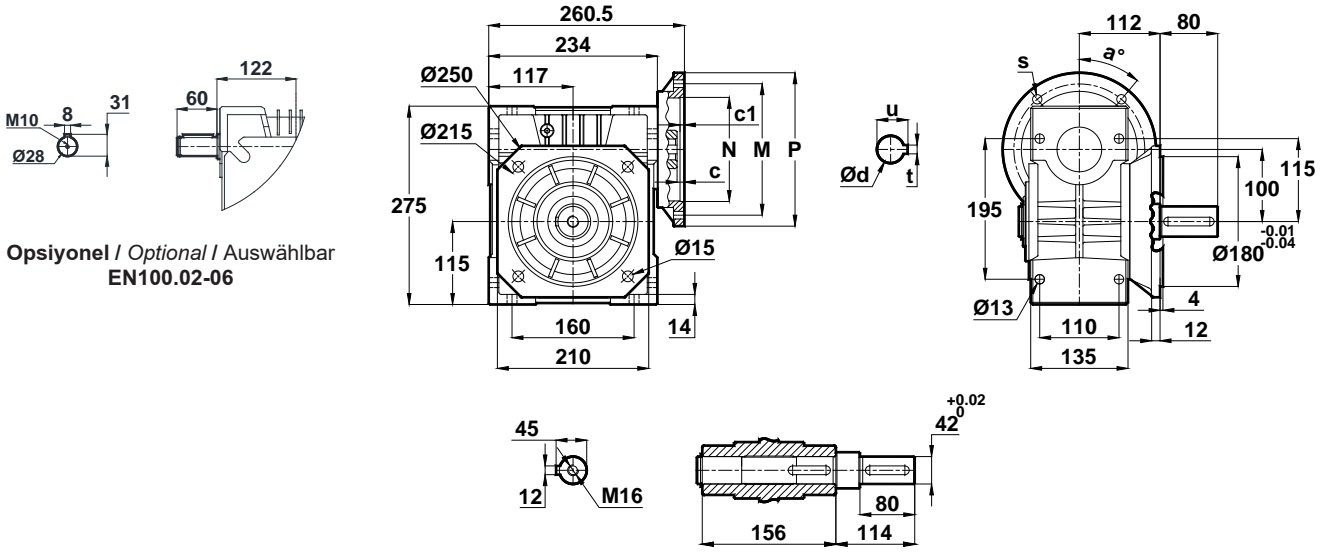

#### EN100.03

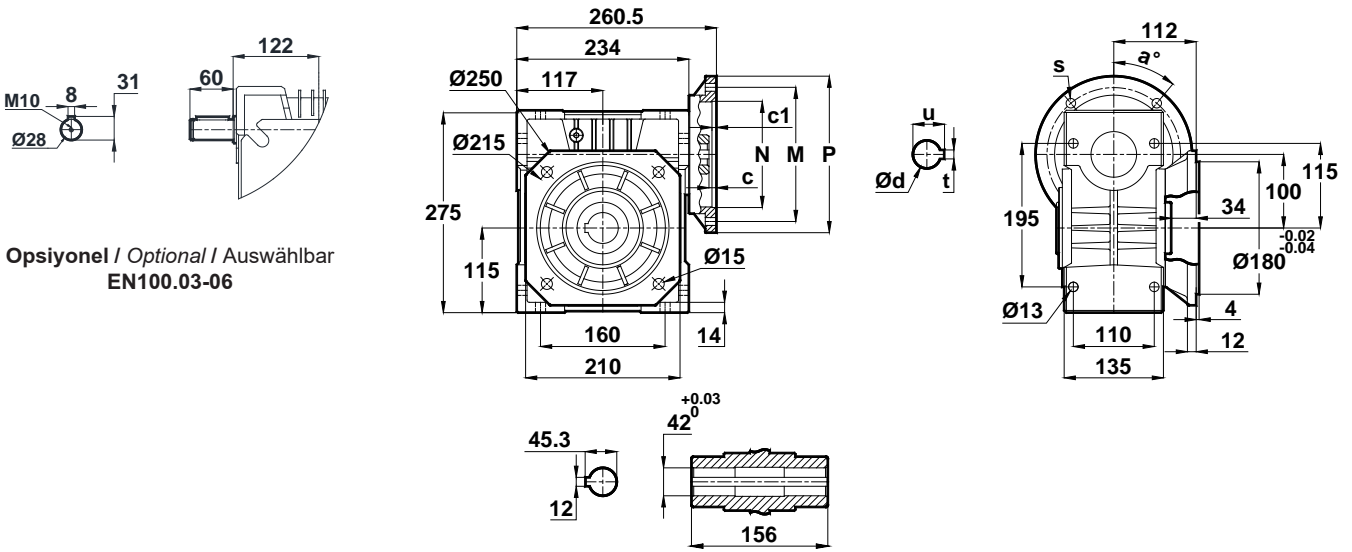

EN100	c	c1	N	M	P	d	u	t	a	s
80/B14	5.5	4	80	100	120	19	21.8	6	45°	7
90/B14	5.5	4	95	115	140	24	27.3	8	45°	9
100-112/B14	5.5	3.5	110	130	160	28	31.3	8	45°	9
80/B5	5.5	4	130	165	200	19	21.8	6	45°	12
90/B5	5.5	4	130	165	200	24	27.3	8	45°	12
100-112/B5	5.5	4.5	180	215	250	28	31.3	8	45°	13

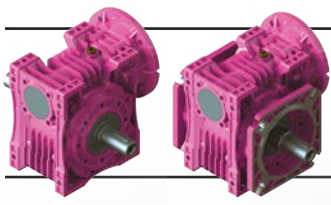

# Ölçü Sayfaları

## Dimension Pages

### Abmessungsseiten

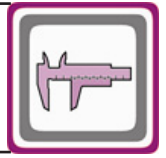

-Mil ucu çekirme deliği DIN 332 sayfa 2 / Tapped center hole to DIN 332, sheet 2 / Zentrierung mit Gewinde DIN 332, Blatt 2

#### EN100.04

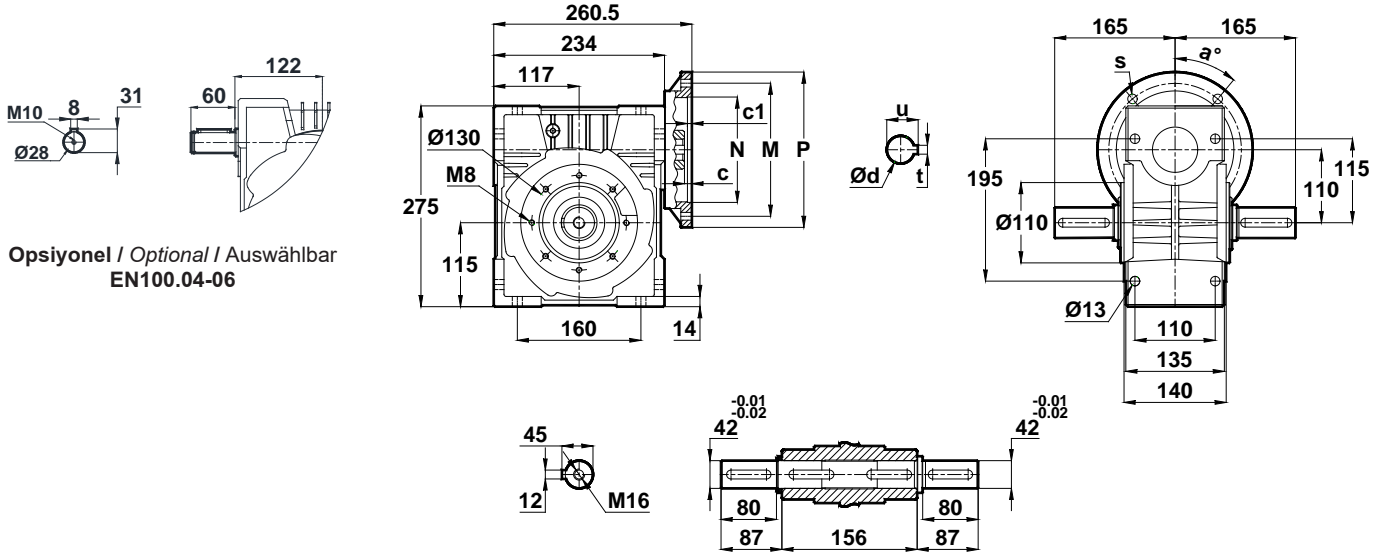

#### EN100.05

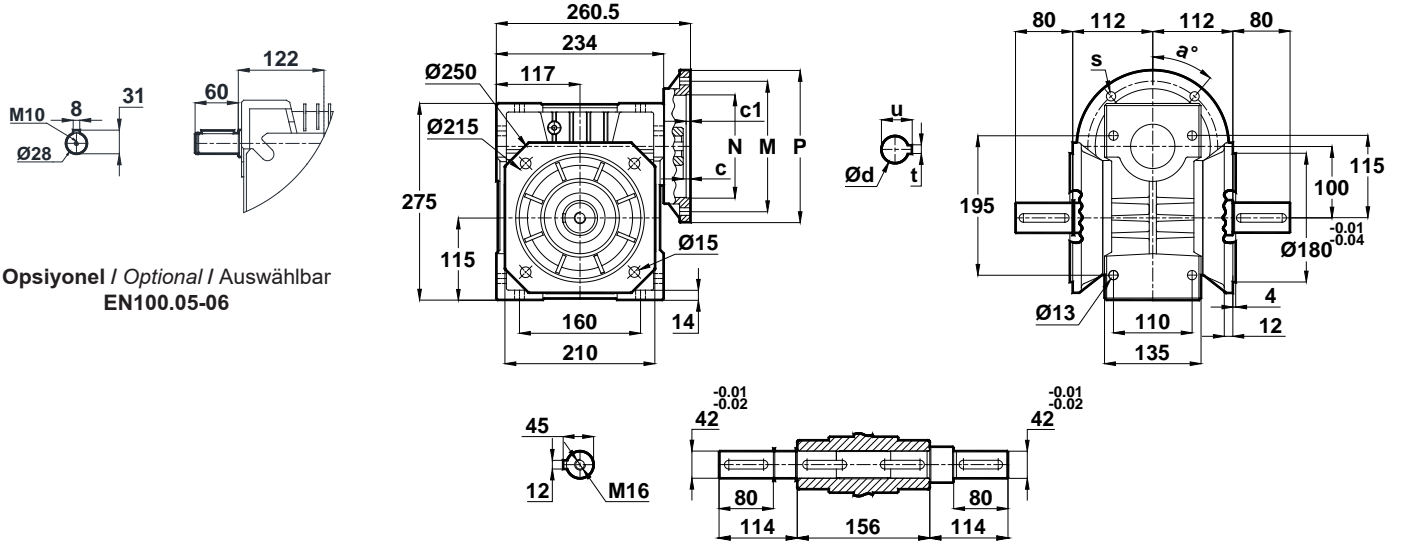

EN100	c	c1	N	M	P	d	u	t	a	s
80/B14	5.5	4	80	100	120	19	21.8	6	45°	7
90/B14	5.5	4	95	115	140	24	27.3	8	45°	9
100-112/B14	5.5	3.5	110	130	160	28	31.3	8	45°	9
80/B5	5.5	4	130	165	200	19	21.8	6	45°	12
90/B5	5.5	4	130	165	200	24	27.3	8	45°	12
100-112/B5	5.5	4.5	180	215	250	28	31.3	8	45°	13





# Ölçü Sayfaları Dimension Pages Abmessungsseiten

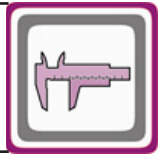

-Mil ucu çekirme deliği DIN 332 sayfa 2 / Tapped center hole to DIN 332, sheet 2 / Zentrierung mit Gewinde DIN 332, Blatt 2

## EN100.08

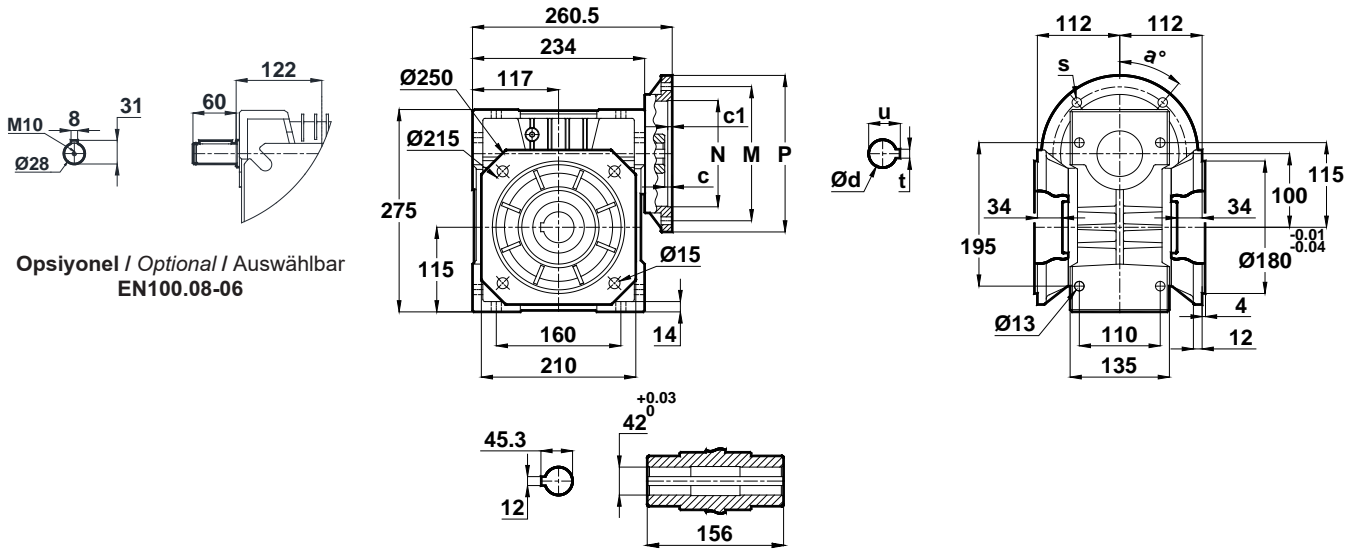

EN100	c	c1	N	M	P	d	u	t	a	s
80/B14	5.5	4	80	100	120	19	21.8	6	45°	7
90/B14	5.5	4	95	115	140	24	27.3	8	45°	9
100-112/B14	5.5	3.5	110	130	160	28	31.3	8	45°	9
80/B5	5.5	4	130	165	200	19	21.8	6	45°	12
90/B5	5.5	4	130	165	200	24	27.3	8	45°	12
100-112/B5	5.5	4.5	180	215	250	28	31.3	8	45°	13

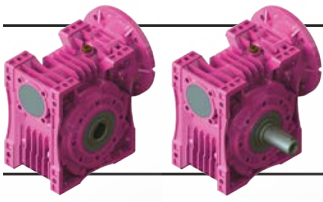

# Ölçü Sayfaları

## Dimension Pages

### Abmessungsseiten

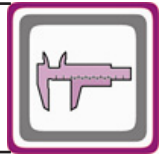

-Mil ucu çekirme deliği DIN 332 sayfa 2 / Tapped center hole to DIN 332, sheet 2 / Zentrierung mit Gewinde DIN 332, Blatt 2

#### EN125.00

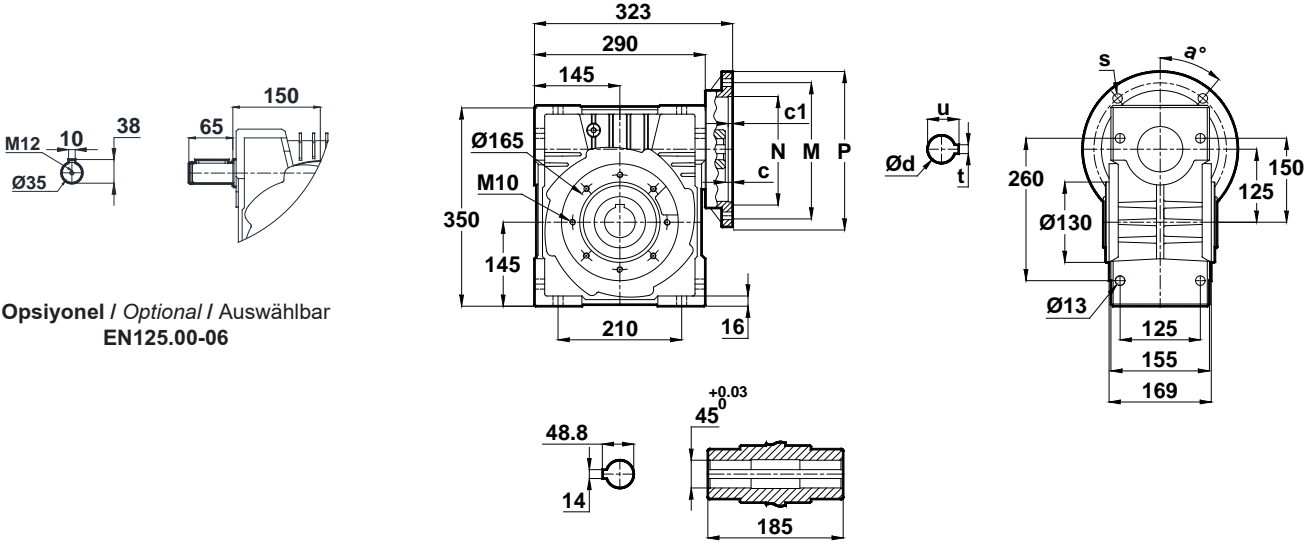

Opsiyonel / Optional / Auswählbar  
EN125.00-06

#### EN125.01

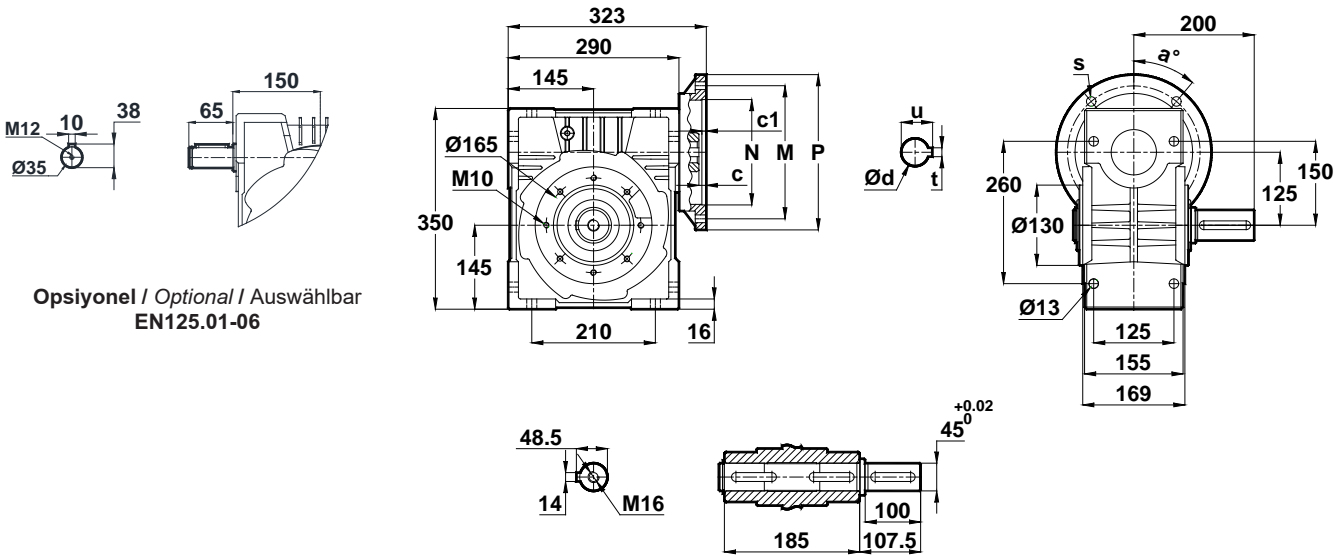

Opsiyonel / Optional / Auswählbar  
EN125.01-06

EN125	c	c1	N	M	P	d	u	t	a	s
100-112/B14	12.8	3.5	110	130	160	28	31.3	8	45°	9
132/B14	12.8	4.5	130	165	200	38	41.3	10	45°	11
90/B5	13.5	4	130	165	200	24	27.3	8	45°	12
100-112/B5	15.8	4.5	180	215	250	28	31.3	8	45°	15
132/B5	15.8	4.5	230	265	300	38	41.3	10	45°	15

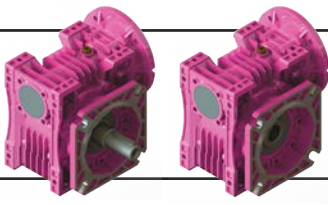

# Ölçü Sayfaları

## Dimension Pages

### Abmessungsseiten

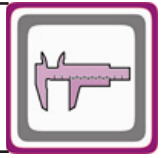

-Mil ucu çekirme deliği DIN 332 sayfa 2 / Tapped center hole to DIN 332, sheet 2 / Zentrierung mit Gewinde DIN 332, Blatt 2

#### EN125.02

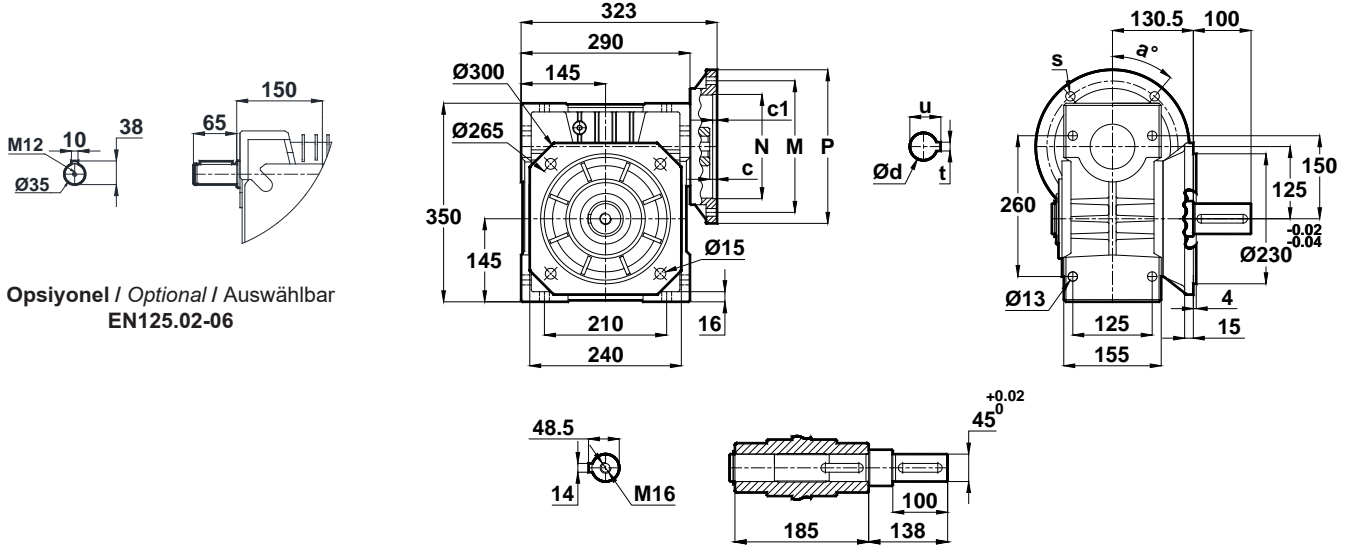

Opsiyonel / Optional / Auswählbar  
EN125.02-06

#### EN125.03

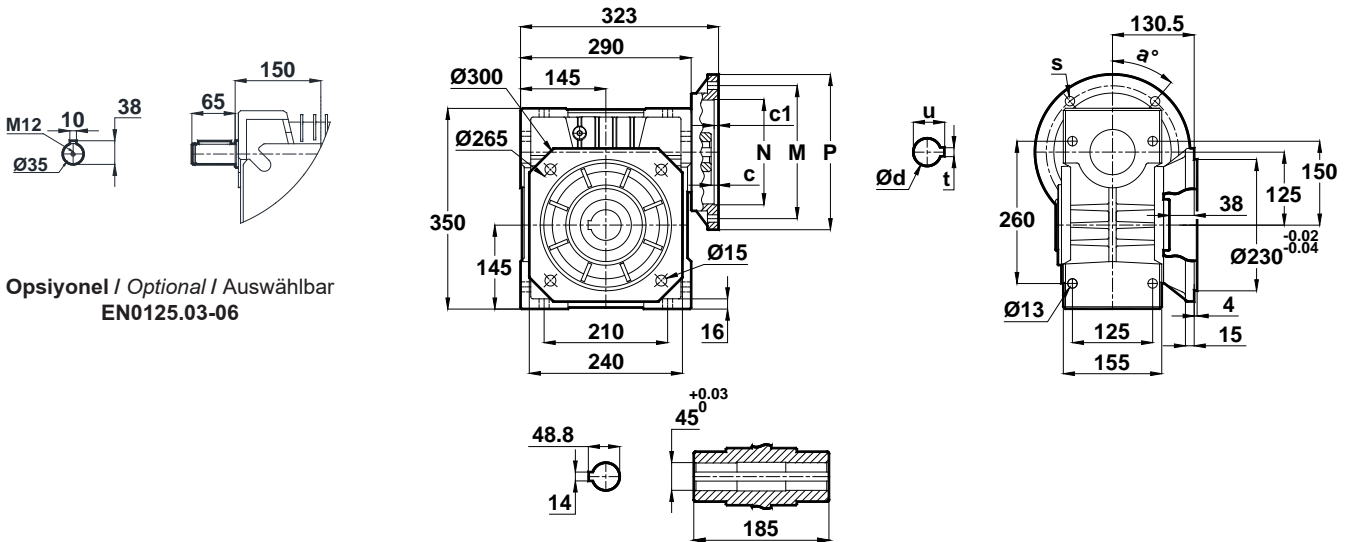

Opsiyonel / Optional / Auswählbar  
EN0125.03-06

EN125	c	c1	N	M	P	d	u	t	a	s
100-112/B14	12.8	3.5	110	130	160	28	31.3	8	45°	9
132/B14	12.8	4.5	130	165	200	38	41.3	10	45°	11
90/B5	13.5	4	130	165	200	24	27.3	8	45°	12
100-112/B5	15.8	4.5	180	215	250	28	31.3	8	45°	15
132/B5	15.8	4.5	230	265	300	38	41.3	10	45°	15

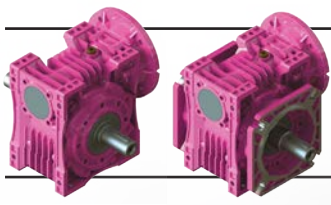

# Ölçü Sayfaları

## Dimension Pages

### Abmessungsseiten

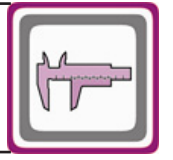

-Mil ucu çekirme deliği DIN 332 sayfa 2 / Tapped center hole to DIN 332, sheet 2 / Zentrierung mit Gewinde DIN 332, Blatt 2

#### EN125.04

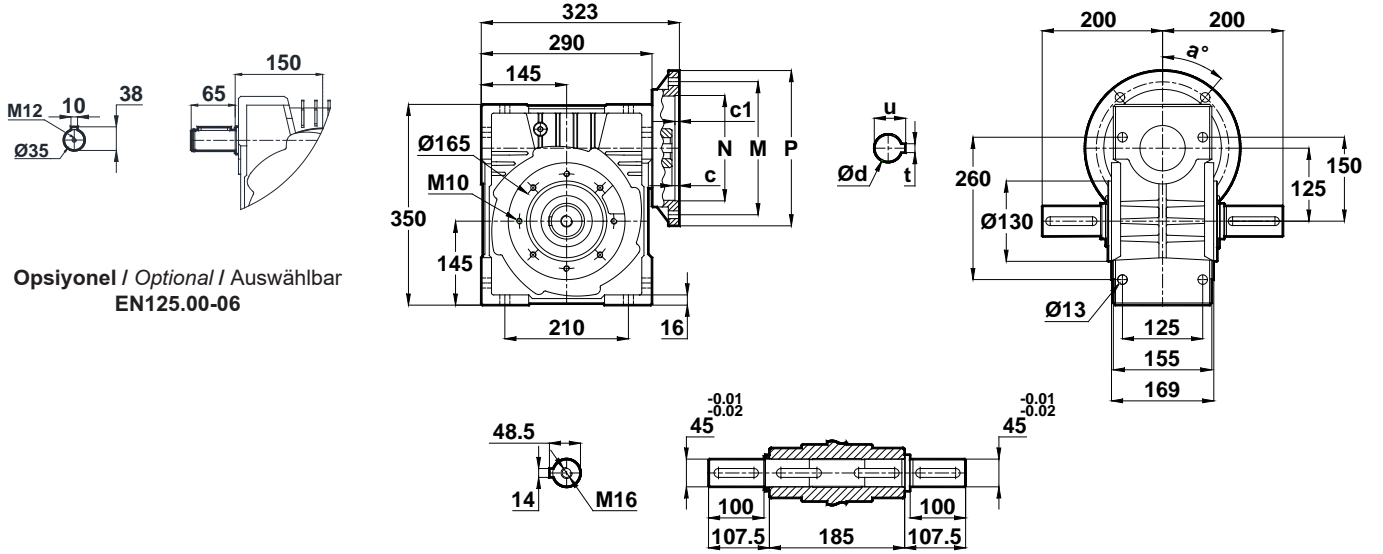

#### EN125.05

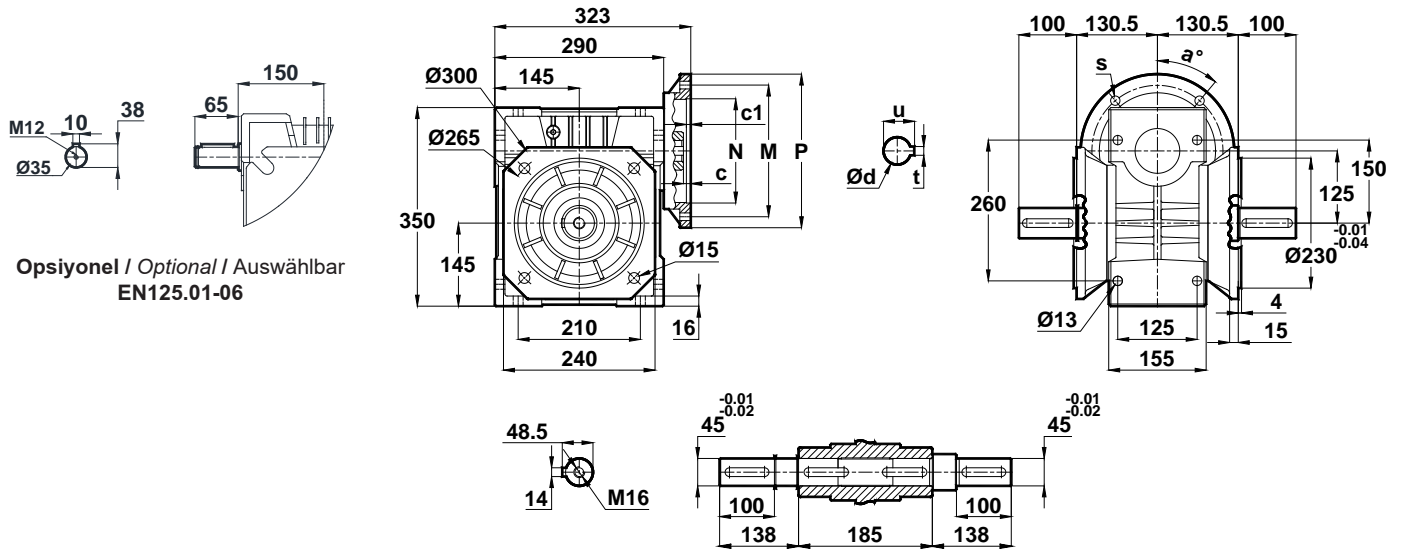

EN125	c	c1	N	M	P	d	u	t	a	s
100-112/B14	12.8	3.5	110	130	160	28	31.3	8	45°	9
132/B14	12.8	4.5	130	165	200	38	41.3	10	45°	11
90/B5	13.5	4	130	165	200	24	27.3	8	45°	12
100-112/B5	15.8	4.5	180	215	250	28	31.3	8	45°	15
132/B5	15.8	4.5	230	265	300	38	41.3	10	45°	15



# Ölçü Sayfaları

## Dimension Pages

### Abmessungsseiten

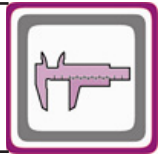

-Mil ucu çekirme deliği DIN 332 sayfa 2 / Tapped center hole to DIN 332, sheet 2 / Zentrierung mit Gewinde DIN 332, Blatt 2

#### EN125.08

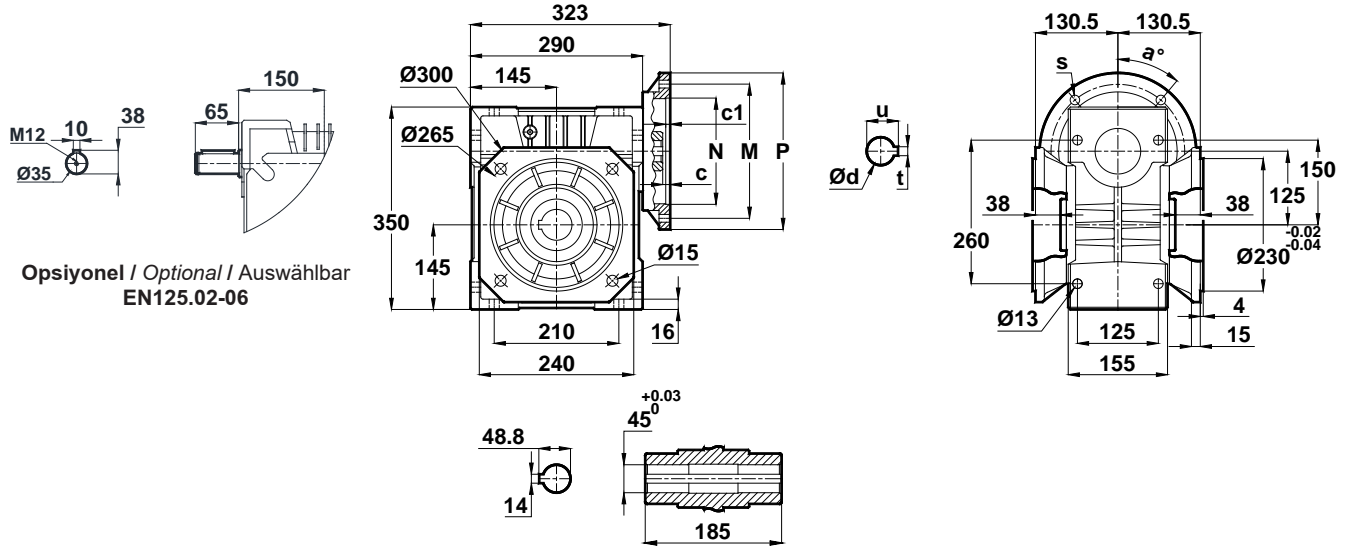

EN125	c	c1	N	M	P	d	u	t	a	s
100-112/B14	12.8	3.5	110	130	160	28	31.3	8	45°	9
132/B14	12.8	4.5	130	165	200	38	41.3	10	45°	11
90/B5	13.5	4	130	165	200	24	27.3	8	45°	12
100-112/B5	15.8	4.5	180	215	250	28	31.3	8	45°	15
132/B5	15.8	4.5	230	265	300	38	41.3	10	45°	15

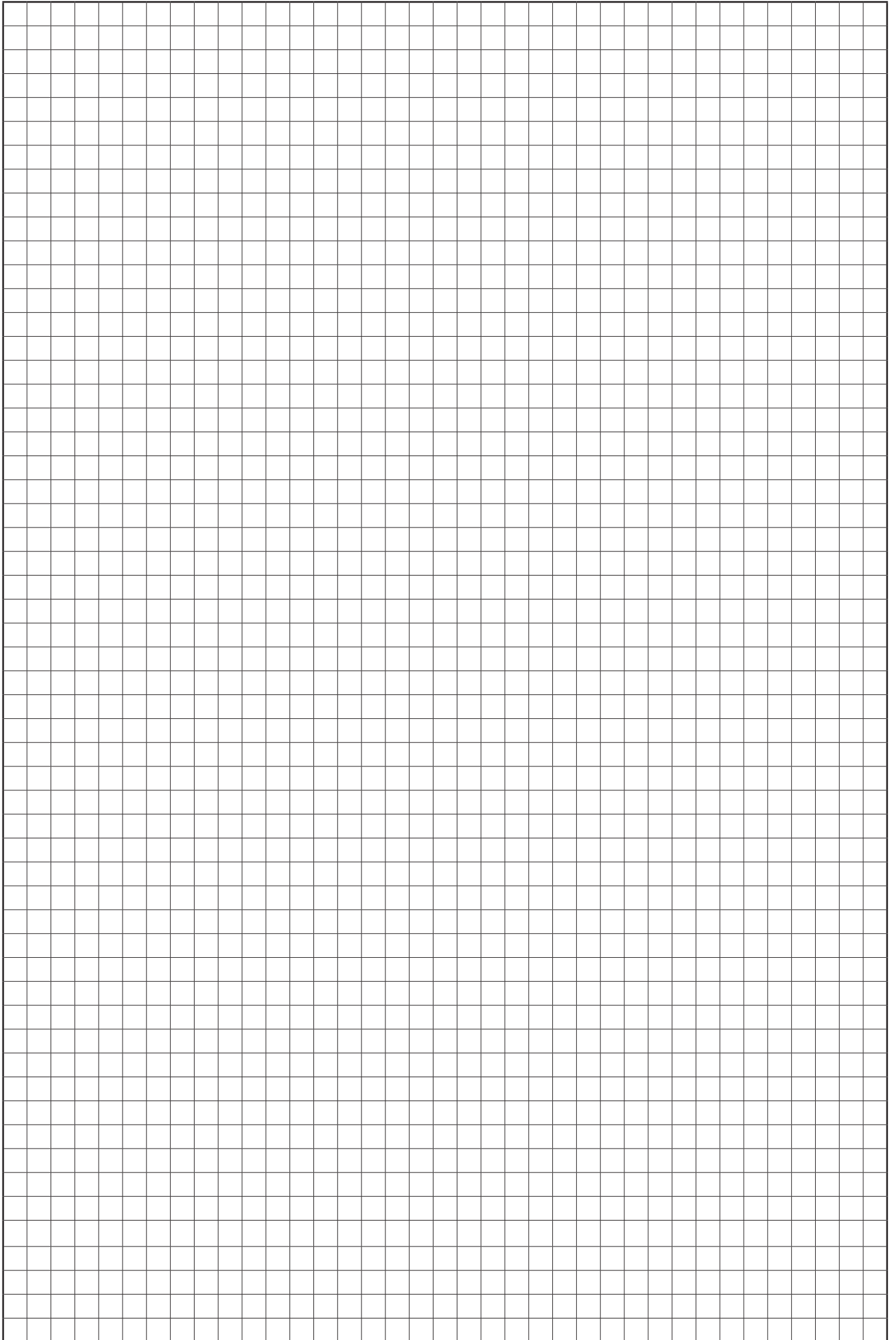



# Güç ve Devir Tabloları

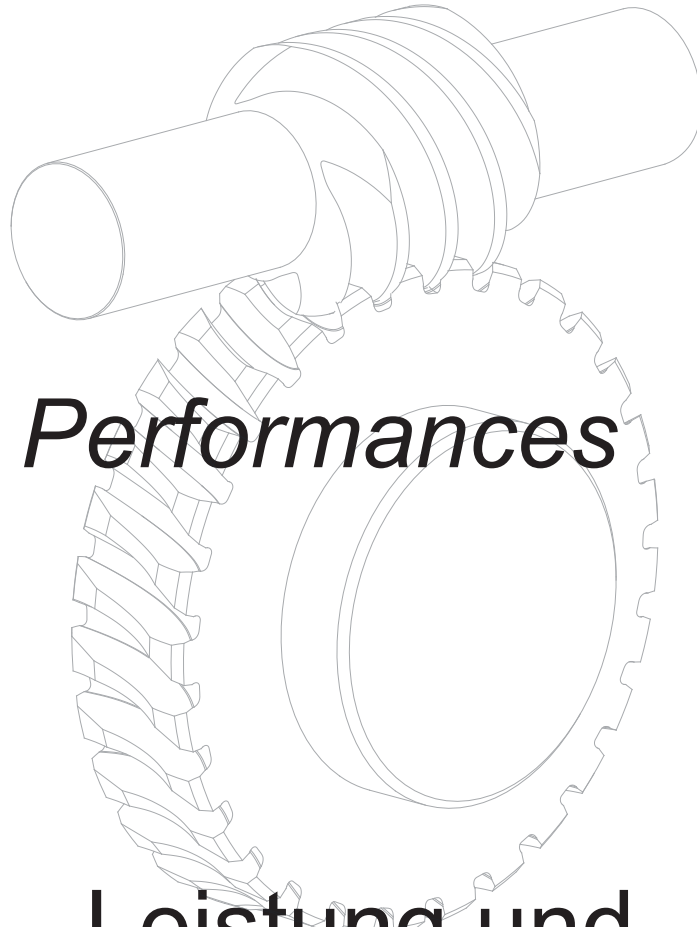

*Performances*

**Leistung und  
Drehzahlübersicht**



# E Serisi Motorsuz Güç Devir Sayfaları

## E Series Gear Units Performance Tables

### E Serien Getriebe Leistung und Drehzahlübersicht

**360**



Tipi Type Typ	Anma Momenti Nominal Torques Nenn-drehmomente	Çevrim Oranı Ratio Übersetzung	Çıkış Devri Output speeds Abtriebs-drehzahl	Giriş Devri Input Speeds Antriebs-drehzahl	Güç Pe/Pt [kW] (Servis Faktörü fs=1,0 için)Pe=Mekanik Güç / Pt=Termik Güç Power Pe/Pt [kW] (For Service Factor fs=1,0) Pe=Mechanical Power / Pt=Thermal Power Leistung Pe/Pt [kW] (Bei Betriebsfaktor fs=1,0) Pe=Mechanische Leistung / Pt=Thermische Leistung				Güv. Rad.Yük Çıkış Per.O.Loads (Output) Zul.Querkräfte (Abtrieb)	Güv.Rad.Yük Giriş Per.O.Loads (Input) Zul.Querkräfte (Antrieb)	Ağırlık Weight Gewicht	Ölçü Sayfası Dim. Page Maß Seite	
	Ma [Nm]	i	n2 [rpm]	n1 [rpm]	Pe [kW]	Pt [kW]	γ	η	Fqam [N]	Fqem [N]	[kg]		
	<b>ET030</b>	24	5,25	69	<b>360</b>	0,21	0,51	26°33'	0,83	1028	205	1,2	178
		21	7,25	50		0,14	0,42	19°26'	0,79	1407	205		
21		10,5	34		0,10	0,34	14°02'	0,74	1703	205			
21		14,5	25		0,08	0,27	10°00'	0,68	1830	205			
21		17	21		0,07	0,24	8°07'	0,63	1830	205			
19		21	17		0,06	0,22	7°07'	0,60	1830	205			
19		25	14		0,05	0,19	5°35'	0,54	1830	205			
18		29	12		0,05	0,18	5°02'	0,51	1830	205			
17		34	11		0,04	0,16	4°05'	0,46	1830	205			
14		42	8,6		0,03	0,15	3°22'	0,42	1830	205			
11		50	7,2		0,02	0,15	3°12'	0,41	1830	205			
7		60	6,0		0,01	0,14	2°45'	0,37	1830	205			
6	80	4,5		0,01	0,12	2°07'	0,32	1830	205				
<b>ET040</b>	54	8,0	45	<b>360</b>	0,31	0,86	26°33'	0,83	1434	358	2,4	182	
	51	10,5	34		0,23	0,71	19°26'	0,79	1823	360			
	54	12	30		0,23	0,59	14°22'	0,75	1863	360			
	49	16	23		0,16	0,57	14°02'	0,74	2328	360			
	46	21	17		0,12	0,46	10°00'	0,68	2669	360			
	43	25	14		0,10	0,41	8°07'	0,64	2919	360			
	42	32	11		0,08	0,38	7°07'	0,61	3260	360			
	39	42	8,6		0,07	0,31	5°02'	0,53	3400	360			
	37	50	7,2		0,06	0,28	4°05'	0,47	3400	360			
	28	62	5,8		0,05	0,24	3°22'	0,37	3400	360			
	23	80	4,5		0,03	0,23	2°51'	0,37	3400	360			
	22	100	3,6		0,02	0,22	2°25'	0,36	3400	360			
<b>ET050</b>	85	7,25	50	<b>360</b>	0,53	1,3	20°40'	0,83	2046	500	4,1	186	
	77	9,5	38		0,39	1,1	19°39'	0,79	2590	500			
	85	12	30		0,35	0,84	13°14'	0,76	2801	500			
	86	14,5	25		0,31	0,84	10°41'	0,73	3073	500			
	76	19	19		0,22	0,71	10°07'	0,68	3697	500			
	77	25	14		0,18	0,65	8°44'	0,65	4199	500			
	78	29	12		0,17	0,54	5°06'	0,58	4241	500			
	65	38	9,5		0,12	0,47	5°23'	0,52	4800	500			
	59	50	7,2		0,09	0,44	4°23'	0,48	4800	500			
	53	62	5,8		0,08	0,38	3°11'	0,41	4800	500			
	46	83	4,3		0,05	0,39	3°22'	0,42	4800	500			
	44	100	3,6		0,04	0,36	2°21'	0,38	4800	500			
<b>ET063</b>	161	7,25	50	<b>360</b>	0,99	2,2	20°36'	0,85	2373	593	6,4	190	
	144	9,75	37		0,68	2,0	20°40'	0,82	3312	700			
	130	12,75	28		0,49	1,7	19°39'	0,79	4121	700			
	164	14,5	25		0,57	1,4	10°39'	0,75	3842	700			
	145	19,5	18		0,38	1,3	10°41'	0,73	4937	700			
	126	25,5	14		0,28	1,1	10°07'	0,67	5818	700			
	148	29	12		0,32	0,86	5°22'	0,59	5448	700			
	129	39	9,2		0,22	0,82	5°23'	0,58	6200	700			
	107	51	7,1		0,15	0,73	5°06'	0,52	6200	700			
	111	61	5,9		0,15	0,64	3°16'	0,45	6200	700			
	86	82	4,4		0,10	0,58	3°11'	0,40	6200	700			
	53	100	3,6		0,06	0,52	2°12'	0,32	6200	700			





# E Serisi Motorsuz Güç Devir Sayfaları

## E Series Gear Units Performance Tables

### E Serien Getriebe Leistung und Drehzahlübersicht

360



Tipi Type Typ	Anma Momenti	Çevrim Oranı	Çıkış Devri	Giriş Devri	Güç Pe/Pt [kW] (Servis Faktörü fs=1,0 için)Pe=Mekanik Güç / Pt=Termik Güç				Güv. Rad.Yük Çıkış	Güv.Rad.Yük Giriş	Ağırlık	Ölçü Sayfası
	Nominal Torques	Ratio	Output speeds	Input Speeds	Power Pe/Pt [kW] (For Service Factor fs=1,0) Pe=Mechanical Power / Pt=Thermal Power				Per.O.Loads (Output)	Per.O.Loads (Input)	Weight	Dim. Page
	Nenn-drehmomente	Übersetzung	Abtriebs-drehzahl	Antriebs-drehzahl	Leistung Pe/Pt [kW] (Bei Betriebsfaktor fs=1,0) Pe=Mechanische Leistung / Pt=Thermische Leistung				Zul.Querkräfte (Abtrieb)	Zul.Querkräfte (Antrieb)	Gewicht	Maß Seite
	Ma [Nm]	i	n2 [rpm]	n1 [rpm]	Pe [kW]	Pt [kW]	γ	η	Fqam [N]	Fqem [N]	[kg]	
ET075	239	7,5	48	360	1,4	3,2	26°17'	0,85	4231	1058	9,2	194
	247	10	36		1,1	2,8	20°20'	0,83	5312	1100		
	252	15	24		0,82	2,2	13°52'	0,78	6810	1100		
	244	20	18		0,62	1,8	11°18'	0,74	7000	1100		
	233	25	14		0,51	1,6	9°32'	0,70	7000	1100		
	238	30	12		0,46	1,4	7°3'	0,64	7000	1100		
	216	40	9,0		0,34	1,2	5°43'	0,59	7000	1100		
	201	50	7,2		0,28	1,1	4°48'	0,55	7000	1100		
	188	60	6,0		0,24	0,97	4°8'	0,50	7000	1100		
	166	80	4,5		0,17	0,89	3°15'	0,45	7000	1100		
128	100	3,6		0,12	0,75	2°40'	0,40	7000	1100			
ET080	322	7,5	48	360	1,9	3,6	21°48'	0,85	2707	677	11,0	198
	300	10	36		1,3	3,3	20°36'	0,84	3875	969		
	266	13,25	27		0,92	3,1	20°40'	0,82	5050	1100		
	335	15	24		1,1	2,3	11°18'	0,77	4621	1100		
	302	20	18		0,78	2,0	10°39'	0,73	5890	1100		
	265	26,5	14		0,53	1,9	10°41'	0,71	7233	1100		
	307	30	12		0,62	1,5	5°42'	0,63	6722	1100		
	270	40	9,0		0,43	1,4	5°22'	0,59	7400	1100		
	233	53	6,8		0,29	1,3	5°23'	0,58	7400	1100		
	180	62	5,8		0,23	1,0	3°13'	0,47	7400	1100		
	118	82	4,4		0,12	1,0	3°16'	0,45	7400	1100		
	76	110	3,3		0,07	0,90	3°11'	0,39	7400	1100		
ET100	567	7,5	48	360	3,3	5,9	21°48'	0,86	3582	895	31,7	202
	513	10	36		2,3	5,5	21°48'	0,85	5312	1300		
	473	13	28		1,6	4,8	20°36'	0,83	6712	1300		
	593	15	24		1,9	3,8	11°18'	0,79	6240	1300		
	528	20	18		1,3	3,5	11°18'	0,77	8188	1300		
	472	26	14		0,92	3,2	10°39'	0,74	8200	1300		
	549	30	12		1,1	2,4	5°42'	0,65	8200	1300		
	479	40	9,0		0,73	2,2	5°42'	0,62	8200	1300		
	418	52	6,9		0,52	2,0	5°22'	0,59	8200	1300		
	375	63	5,7		0,44	1,7	3°21'	0,51	8200	1300		
	237	82	4,4		0,23	1,6	3°13'	0,47	8200	1300		
	154	107	3,4		0,12	1,5	3°16'	0,45	8200	1300		
	ET125	1035	7,25	50	360	6,1	10	21°48'	0,88	3778		
933		10	36		4,1	9,0	21°48'	0,86	5879	1470		
837		13	28		2,9	8,3	21°48'	0,85	7877	1800		
1084		14,5	25		3,5	6,3	11°18'	0,80	6540	1635		
967		20	18		2,3	5,8	11°18'	0,79	9513	1800		
855		26	14		1,6	5,3	11°18'	0,77	11769	1800		
1028		29	12		2,0	3,8	5°42'	0,67	10065	1800		
885		40	9,0		1,3	3,6	5°42'	0,65	13000	1800		
767		52	6,9		0,88	3,4	5°42'	0,63	13000	1800		
772		62	5,8		0,89	2,7	3°24'	0,53	13000	1800		
494		83	4,3		0,44	2,6	3°22'	0,51	13000	1800		
310		107	3,4		0,23	2,4	3°13'	0,47	13000	1800		



# E Serisi Motorsuz Güç Devir Sayfaları

## E Series Gear Units Performance Tables

### E Serien Getriebe Leistung und Drehzahlübersicht

475

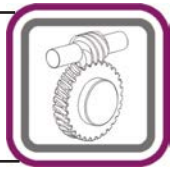

Tipi Type Typ	Anma Momenti Nominal Torques Nenn-drehmomente	Çevrim Oranı Ratio Übersetzung	Çıkış Devri Output speeds Abtriebs-drehzahl	Giriş Devri Input Speeds Antriebs-drehzahl	Güç Pe/Pt [kW] (Servis Faktörü $f_s=1,0$ için) $P_e$ =Mekanik Güç / Pt=Termik Güç Power Pe/Pt [kW] (For Service Factor $f_s=1,0$ ) $P_e$ =Mechanical Power / Pt=Thermal Power Leistung Pe/Pt [kW] (Bei Betriebsfaktor $f_s=1,0$ ) $P_e$ =Mechanische Leistung / Pt=Thermische Leistung				Güv. Rad.Yük Çıkış Per.O.Loads (Output) Zul.Querkräfte (Abtrieb)	Güv.Rad.Yük Giriş Per.O.Loads (Input) Zul.Querkräfte (Antrieb)	Ağırlık Weight Gewicht	Ölçü Sayfası Dim. Page Maß Seite	
	Ma [Nm]	i	n2 [rpm]	n1 [rpm]	Pe [kW]	Pt [kW]	$\gamma$	$\eta$	Fqam [N]	Fqem [N]	[kg]		
	<b>ET030</b>	22	5,25	90	<b>475</b>	0,26	0,50	26°33'	0,83	915	205	1,2	178
		20	7,25	66		0,17	0,41	19°26'	0,79	1265	205		
19		10,5	45		0,12	0,33	14°02'	0,74	1533	205			
20		14,5	33		0,10	0,27	10°00'	0,68	1771	205			
19		17	28		0,09	0,23	8°07'	0,63	1830	205			
18		21	23		0,07	0,21	7°07'	0,60	1830	205			
18		25	19		0,07	0,19	5°35'	0,54	1830	205			
17		29	16		0,06	0,18	5°02'	0,51	1830	205			
16		34	14		0,05	0,16	4°05'	0,46	1830	205			
14		42	11		0,04	0,15	3°22'	0,42	1830	205			
11		50	10		0,03	0,14	3°12'	0,41	1830	205			
7		60	7,9		0,02	0,14	2°45'	0,37	1830	205			
6	80	5,9		0,01	0,13	2°07'	0,35	1830	205				
<b>ET040</b>	51	8,0	59	<b>475</b>	0,38	0,84	26°33'	0,83	1273	318	2,4	182	
	48	10,5	45		0,29	0,70	19°26'	0,79	1630	360			
	53	12	40		0,28	0,66	14°22'	0,78	1662	360			
	47	16	30		0,20	0,56	14°02'	0,74	2089	360			
	44	21	23		0,15	0,46	10°00'	0,68	2399	360			
	43	25	19		0,13	0,41	8°07'	0,64	2590	360			
	41	32	15		0,10	0,38	7°07'	0,61	2936	360			
	38	42	11		0,09	0,31	5°02'	0,53	3239	360			
	36	50	10		0,08	0,28	4°05'	0,47	3400	360			
	30	62	7,7		0,06	0,22	3°22'	0,40	3400	360			
	23	80	5,9		0,04	0,20	2°51'	0,38	3400	360			
	20	100	4,8		0,03	0,17	2°25'	0,36	3400	360			
<b>ET050</b>	81	7,25	66	<b>475</b>	0,66	1,4	20°40'	0,84	1819	455	4,1	186	
	75	9,5	50		0,48	1,2	19°39'	0,82	2318	500			
	82	12	40		0,44	0,99	13°14'	0,77	2504	500			
	83	14,5	33		0,38	0,87	10°41'	0,74	2751	500			
	76	19	25		0,28	0,80	10°07'	0,72	3322	500			
	78	25	19		0,23	0,72	8°44'	0,69	3776	500			
	76	29	16		0,22	0,56	5°23'	0,60	3802	500			
	68	38	13		0,16	0,52	5°06'	0,57	4486	500			
	63	50	10		0,12	0,48	4°23'	0,53	4800	500			
	57	62	7,7		0,10	0,41	3°11'	0,45	4800	500			
	45	83	5,7		0,06	0,39	3°22'	0,42	4800	500			
	37	100	4,8		0,05	0,36	2°21'	0,38	4800	500			
<b>ET063</b>	152	7,25	66	<b>475</b>	1,2	2,3	20°36'	0,85	2087	522	6,4	190	
	138	9,75	49		0,84	2,1	20°40'	0,84	2947	700			
	127	12,75	37		0,61	1,9	19°39'	0,82	3691	700			
	159	14,5	33		0,71	1,5	10°39'	0,76	3417	700			
	140	19,5	24		0,48	1,4	10°41'	0,75	4424	700			
	127	25,5	19		0,35	1,2	10°07'	0,71	5225	700			
	147	29	16		0,41	0,90	5°22'	0,62	4854	700			
	127	39	12		0,27	0,84	5°23'	0,59	6041	700			
	112	51	9,3		0,19	0,79	5°06'	0,56	6200	700			
	111	61	7,8		0,19	0,65	3°16'	0,47	6200	700			
	94	82	5,8		0,13	0,62	3°11'	0,44	6200	700			
	61	100	4,8		0,08	0,55	2°12'	0,37	6200	700			



# E Serisi Motorsuz Güç Devir Sayfaları

## E Series Gear Units Performance Tables

### E Serien Getriebe Leistung und Drehzahlübersicht

475



Tipi	Anma Momenti	Çevrim Oranı	Çıkış Devri	Giriş Devri	Güç Pe/Pt [kW] (Servis Faktörü fs=1,0 için)Pe=Mekanik Güç / Pt=Termik Güç				Güv. Rad.Yük Çıkış	Güv.Rad.Yük Giriş	Ağırlık	Ölçü Sayfası
	Nominal Torques	Ratio	Output speeds	Input Speeds	Power Pe/Pt [kW] (For Service Factor fs=1,0) Pe=Mechanical Power / Pt=Thermal Power				Per.O.Loads (Output)	Per.O.Loads (Input)	Weight	Dim. Page
	Nenn-drehmomente	Übersetzung	Abtriebs-drehzahl	Antriebs-drehzahl	Leistung Pe/Pt [kW] (Bei Betriebsfaktor fs=1,0) Pe=Mechanische Leistung / Pt=Thermische Leistung				Zul.Querkräfte (Abtrieb)	Zul.Querkräfte (Antrieb)	Gewicht	Maß Seite
	Ma [Nm]	i	n2 [rpm]	n1 [rpm]	Pe [kW]	Pt [kW]	γ	η	Fqam [N]	Fqem [N]	[kg]	
<b>ET075</b>	<b>228</b>	7,5	63	<b>475</b>	1,8	3,3	26°17'	0,86	3725	931	9,2	194
	<b>236</b>	10	48		1,4	3,0	20°20'	0,84	4711	1100		
	<b>243</b>	15	32		1,0	2,3	13°52'	0,79	6064	1100		
	<b>236</b>	20	24		0,78	1,9	11°18'	0,75	7000	1100		
	<b>230</b>	25	19		0,64	1,7	9°32'	0,72	7000	1100		
	<b>233</b>	30	16		0,59	1,4	7°3'	0,66	7000	1100		
	<b>218</b>	40	12		0,44	1,3	5°43'	0,62	7000	1100		
	<b>205</b>	50	10		0,35	1,1	4°48'	0,58	7000	1100		
	<b>187</b>	60	7,9		0,30	0,98	4°8'	0,51	7000	1100		
	<b>167</b>	80	5,9		0,22	0,90	3°15'	0,47	7000	1100		
<b>133</b>	100	4,8		0,16	0,82	2°40'	0,42	7000	1100			
<b>ET080</b>	<b>306</b>	7,5	63	<b>475</b>	2,4	3,7	21°48'	0,85	2357	589	11,0	198
	<b>285</b>	10	48		1,7	3,5	20°36'	0,84	3433	858		
	<b>256</b>	13,25	36		1,1	3,3	20°40'	0,84	4511	1100		
	<b>322</b>	15	32		1,4	2,4	11°18'	0,78	4090	1023		
	<b>294</b>	20	24		0,98	2,1	10°39'	0,75	5249	1100		
	<b>257</b>	26,5	18		0,67	2,0	10°41'	0,72	6482	1100		
	<b>301</b>	30	16		0,78	1,5	5°42'	0,64	5977	1100		
	<b>270</b>	40	12		0,54	1,4	5°22'	0,62	7367	1100		
	<b>231</b>	53	9,0		0,37	1,3	5°23'	0,59	7400	1100		
	<b>189</b>	62	7,7		0,31	1,1	3°13'	0,49	7400	1100		
	<b>122</b>	82	5,8		0,16	1,0	3°16'	0,47	7400	1100		
	<b>85</b>	110	4,3		0,09	0,96	3°11'	0,44	7400	1100		
	<b>ET100</b>	<b>541</b>	7,5	63	<b>475</b>	4,1	6,3	21°48'	0,87	3110		
<b>488</b>		10	48		2,8	5,6	21°48'	0,85	4701	1175		
<b>450</b>		13	37		2,1	5,0	20°36'	0,84	5984	1300		
<b>570</b>		15	32		2,4	4,1	11°18'	0,80	5521	1300		
<b>510</b>		20	24		1,6	3,8	11°18'	0,78	7311	1300		
<b>461</b>		26	18		1,2	3,4	10°39'	0,76	8200	1300		
<b>545</b>		30	16		1,3	2,5	5°42'	0,67	8110	1300		
<b>472</b>		40	12		0,93	2,3	5°42'	0,63	8200	1300		
<b>419</b>		52	9,1		0,66	2,1	5°22'	0,61	8200	1300		
<b>389</b>		63	7,5		0,58	1,7	3°22'	0,53	8200	1300		
<b>250</b>		82	5,8		0,30	1,6	3°13'	0,50	8200	1300		
<b>159</b>		107	4,4		0,16	1,5	3°16'	0,46	8200	1300		
<b>ET125</b>	<b>988</b>	7,25	66	<b>475</b>	7,6	11	21°48'	0,89	3554	889	62,2	206
	<b>893</b>	10	48		5,1	9,6	21°48'	0,87	5162	1290		
	<b>799</b>	13	37		3,6	8,6	21°48'	0,85	6997	1749		
	<b>1051</b>	14,5	33		4,4	6,9	11°18'	0,82	5717	1429		
	<b>934</b>	20	24		2,9	6,2	11°18'	0,80	8457	1800		
	<b>828</b>	26	18		2,0	5,7	11°18'	0,78	10527	1800		
	<b>1022</b>	29	16		2,5	4,2	5°42'	0,70	8869	1800		
	<b>884</b>	40	12		1,6	3,8	5°42'	0,67	12074	1800		
	<b>759</b>	52	9,1		1,1	3,6	5°42'	0,65	13000	1800		
	<b>811</b>	62	7,7		1,2	2,8	3°24'	0,56	13000	1800		
	<b>512</b>	83	5,7		0,58	2,7	3°22'	0,53	13000	1800		
	<b>326</b>	107	4,4		0,30	2,5	3°13'	0,50	13000	1800		



# E Serisi Motorsuz Güç Devir Sayfaları

## E Series Gear Units Performance Tables

### E Serien Getriebe Leistung und Drehzahlübersicht

**725**

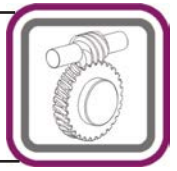

Tipi  Type  Typ	Anma Momenti	Çevrim Oranı	Çıkış Devri	Giriş Devri	Güç Pe/Pt [kW] (Servis Faktörü $f_s=1,0$ için)Pe=Mekanik Güç / Pt=Termik Güç				Güv. Rad.Yük Çıkış	Güv.Rad.Yük Giriş	Ağırlık	Ölçü Sayfası
	Nominal Torques	Ratio	Output speeds	Input Speeds	Power Pe/Pt [kW] (For Service Factor $f_s=1,0$ ) Pe=Mechanical Power / Pt=Thermal Power				Per.O.Loads (Output)	Per.O.Loads (Input)	Weight	Dim. Page
	Nenn-drehmomente	Übersetzung	Abtriebs-drehzahl	Antriebs-drehzahl	Leistung Pe/Pt [kW] (Bei Betriebsfaktor $f_s=1,0$ ) Pe=Mechanische Leistung / Pt=Thermische Leistung				Zul.Querkräfte (Abtrieb)	Zul.Querkräfte (Antrieb)	Gewicht	Maß Seite
	Ma [Nm]	i	n2 [rpm]	n1 [rpm]	Pe [kW]	Pt [kW]	$\gamma$	$\eta$	Fqam [N]	Fqem [N]	[kg]	
<b>ET030</b>	<b>21</b>	5,25	138	<b>725</b>	0,35	0,60	26°33'	0,86	765	191	1,2	178
	19	7,25	100		0,24	0,49	19°26'	0,83	1073	205		
	19	10,5	69		0,17	0,39	14°02'	0,78	1305	205		
	19	14,5	50		0,14	0,31	10°00'	0,73	1509	205		
	19	17	43		0,13	0,27	8°07'	0,68	1596	205		
	18	21	35		0,10	0,24	7°07'	0,65	1775	205		
	18	25	29		0,09	0,21	5°35'	0,60	1830	205		
	18	29	25		0,08	0,20	5°02'	0,57	1830	205		
	17	34	21		0,07	0,18	4°05'	0,52	1830	205		
	16	42	17		0,06	0,16	3°22'	0,48	1830	205		
	13	50	15		0,04	0,16	3°12'	0,47	1830	205		
	9	60	12		0,03	0,14	2°45'	0,42	1830	205		
8	80	9,1		0,02	0,13	2°07'	0,41	1830	205			
<b>ET040</b>	<b>48</b>	8,0	91	<b>725</b>	0,53	0,99	26°33'	0,85	1060	265	2,4	182
	46	10,5	69		0,40	0,82	19°26'	0,82	1372	343		
	50	12	60		0,40	0,70	14°22'	0,79	1395	349		
	46	16	45		0,28	0,65	14°02'	0,78	1770	360		
	44	21	35		0,22	0,53	10°00'	0,73	2038	360		
	44	25	29		0,19	0,48	8°07'	0,70	2195	360		
	41	32	23		0,15	0,44	7°07'	0,67	2504	360		
	40	42	17		0,12	0,35	5°02'	0,59	2760	360		
	38	50	15		0,11	0,31	4°05'	0,53	2942	360		
	29	62	12		0,08	0,24	3°22'	0,43	3279	360		
	27	80	9,1		0,06	0,21	2°51'	0,43	3400	360		
	27	100	7,3		0,05	0,18	2°25'	0,41	3400	360		
<b>ET050</b>	<b>75</b>	7,25	100	<b>725</b>	0,92	1,5	20°40'	0,85	1518	379	4,1	186
	70	9,5	76		0,67	1,4	19°39'	0,84	1956	489		
	77	12	60		0,61	1,1	13°14'	0,79	2109	500		
	79	14,5	50		0,54	0,96	10°41'	0,77	2323	500		
	73	19	38		0,39	0,87	10°07'	0,75	2822	500		
	76	25	29		0,32	0,78	8°44'	0,72	3212	500		
	75	29	25		0,31	0,61	5°23'	0,64	3218	500		
	67	38	19		0,22	0,56	5°06'	0,60	3816	500		
	62	50	15		0,17	0,50	4°23'	0,56	4366	500		
	59	62	12		0,15	0,44	3°11'	0,50	4688	500		
	50	83	8,7		0,09	0,43	3°22'	0,48	4800	500		
	50	100	7,3		0,08	0,39	2°21'	0,45	4800	500		
<b>ET063</b>	<b>142</b>	7,25	100	<b>725</b>	1,7	2,6	20°36'	0,87	1711	428	6,4	190
	128	9,75	74		1,2	2,2	20°40'	0,84	2462	700		
	120	12,75	57		0,85	2,1	19°39'	0,84	3117	700		
	150	14,5	50		1,0	1,6	10°39'	0,79	2856	700		
	134	19,5	37		0,67	1,5	10°41'	0,77	3743	700		
	123	25,5	28		0,50	1,3	10°08'	0,73	4431	700		
	144	29	25		0,58	0,96	5°22'	0,65	4072	700		
	127	39	19		0,39	0,91	5°23'	0,62	5112	700		
	113	51	14		0,28	0,85	5°06'	0,60	6007	700		
	114	61	12		0,28	0,69	3°16'	0,51	6112	700		
	98	82	8,8		0,19	0,65	3°11'	0,48	6200	700		
	67	100	7,3		0,13	0,57	2°12'	0,40	6200	700		



# E Serisi Motorsuz Güç Devir Sayfaları

## E Series Gear Units Performance Tables

### E Serien Getriebe Leistung und Drehzahlübersicht

725



Tipi	Anma Momenti	Çevrim Oranı	Çıkış Devri	Giriş Devri	Güç Pe/Pt [kW] (Servis Faktörü fs=1,0 için)Pe=Mekanik Güç / Pt=Termik Güç				Güv. Rad.Yük Çıkış	Güv.Rad.Yük Giriş	Ağırlık	Ölçü Sayfası
	Nominal Torques	Ratio	Output speeds	Input Speeds	Power Pe/Pt [kW] (For Service Factor fs=1,0) Pe=Mechanical Power / Pt=Thermal Power				Per.O.Loads (Output)	Per.O.Loads (Input)	Weight	Dim. Page
	Nenn-drehmomente	Übersetzung	Abtriebs-drehzahl	Antriebs-drehzahl	Leistung Pe/Pt [kW] (Bei Betriebsfaktor fs=1,0) Pe=Mechanische Leistung / Pt=Thermische Leistung				Zul.Querkräfte (Abtrieb)	Zul.Querkräfte (Antrieb)	Gewicht	Maß Seite
	Ma [Nm]	i	n2 [rpm]	n1 [rpm]	Pe [kW]	Pt [kW]	γ	η	Fqam [N]	Fqem [N]	[kg]	
ET075	212	7,5	97	725	2,5	3,6	26°17'	0,87	3051	763	9,2	194
	220	10	73		2,0	3,2	20°20'	0,85	3920	980		
	229	15	48		1,4	2,5	13°53'	0,81	5075	1100		
	224	20	36		1,1	2,0	11°18'	0,77	6074	1100		
	220	25	29		0,91	1,8	9°32'	0,74	6868	1100		
	228	30	24		0,84	1,5	7°3'	0,69	7000	1100		
	214	40	18		0,62	1,4	5°43'	0,65	7000	1100		
	201	50	15		0,51	1,2	4°48'	0,60	7000	1100		
	191	60	12		0,44	1,0	4°08'	0,54	7000	1100		
	173	80	9,1		0,32	0,96	3°15'	0,51	7000	1100		
146	100	7,3		0,24	0,87	2°40'	0,46	7000	1100			
ET080	287	7,5	97	725	3,3	4,3	21°48'	0,88	1929	482	11,0	198
	266	10	73		2,3	3,9	20°36'	0,86	2845	711		
	238	13,25	55		1,6	3,5	20°40'	0,85	3793	948		
	307	15	48		1,9	2,7	11°18'	0,81	3390	848		
	279	20	36		1,4	2,3	10°39'	0,77	4400	1100		
	248	26,5	27		0,95	2,1	10°41'	0,74	5480	1100		
	302	30	24		1,1	1,7	5°42'	0,69	4993	1100		
	266	40	18		0,78	1,5	5°22'	0,65	6211	1100		
	232	53	14		0,53	1,4	5°23'	0,63	7400	1100		
	207	62	12		0,47	1,2	3°13'	0,54	7400	1100		
	133	82	8,8		0,24	1,1	3°16'	0,51	7400	1100		
	93	110	6,6		0,13	1,0	3°11'	0,47	7400	1100		
	-											
ET100	505	7,5	97	725	5,7	7,4	21°48'	0,89	2719	680	31,7	202
	458	10	73		4,0	6,5	21°48'	0,87	3892	973		
	422	13	56		2,9	5,5	20°36'	0,85	5013	1253		
	548	15	48		3,3	5,0	11°18'	0,84	4577	1144		
	488	20	36		2,3	4,3	11°18'	0,81	6149	1300		
	441	26	28		1,7	3,7	10°39'	0,78	7432	1300		
	549	30	24		1,9	3,0	5°42'	0,73	6773	1300		
	477	40	18		1,3	2,5	5°42'	0,68	8200	1300		
	417	52	14		0,96	2,2	5°22'	0,63	8200	1300		
	434	63	12		0,89	2,0	3°21'	0,59	8200	1300		
	274	82	8,8		0,46	1,8	3°13'	0,55	8200	1300		
	174	107	6,8		0,24	1,6	3°16'	0,50	8200	1300		
	ET125	918	7,25	100	725	11	14	21°48'	0,91	3582	896	62,2
836		10	73		7,1	11	21°48'	0,89	4219	1055		
753		13	56		5,0	9,9	21°48'	0,87	5832	1458		
1006		14,5	50		6,2	8,4	11°19'	0,85	4649	1162		
901		20	36		4,1	7,5	11°19'	0,84	7068	1767		
796		26	28		2,9	6,4	11°19'	0,81	8887	1800		
1022		29	25		3,5	5,0	5°43'	0,75	7312	1800		
894		40	18		2,3	4,6	5°43'	0,73	10146	1800		
771		52	14		1,6	4,1	5°43'	0,70	12339	1800		
852		62	12		1,7	3,3	3°24'	0,62	12048	1800		
572		83	8,7		0,89	3,0	3°22'	0,59	13000	1800		
357		107	6,8		0,46	2,7	3°13'	0,55	13000	1800		



# E Serisi Motorsuz Güç Devir Sayfaları

## E Series Gear Units Performance Tables

### E Serien Getriebe Leistung und Drehzahlübersicht

950

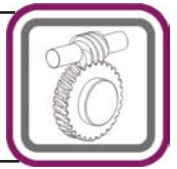

Tipi Type Typ	Anma Momenti Nominal Torques Nenn-drehmomente	Çevrim Oranı Ratio Übersetzung	Çıkış Devri Output speeds Abtriebs-drehzahl	Giriş Devri Input Speeds Antriebs-drehzahl	Güç Pe/Pt [kW] (Servis Faktörü $f_s=1,0$ için)Pe=Mekanik Güç / Pt=Termik Güç Power Pe/Pt [kW] (For Service Factor $f_s=1,0$ ) Pe=Mechanical Power / Pt=Thermal Power Leistung Pe/Pt [kW] (Bei Betriebsfaktor $f_s=1,0$ ) Pe=Mechanische Leistung / Pt=Thermische Leistung				Güv. Rad.Yük Çıkış Per.O.Loads (Output) Zul.Querkräfte (Abtrieb)	Güv.Rad.Yük Giriş Per.O.Loads (Input) Zul.Querkräfte (Antrieb)	Ağırlık Weight Gewicht	Ölçü Sayfası Dim. Page Maß Seite	
	Ma [Nm]	i	n2 [rpm]	n1 [rpm]	Pe [kW]	Pt [kW]	$\gamma$	$\eta$	Fqam [N]	Fqem [N]	[kg]		
	ET030	20	5,25	181	950	0,44	0,63	26°33'	0,87	683	171	1,2	178
		18	7,25	131		0,29	0,52	19°26'	0,84	967	205		
18		10,5	90		0,21	0,41	14°02'	0,80	1178	205			
19		14,5	66		0,17	0,32	10°00'	0,74	1364	205			
19		17	56		0,16	0,28	8°07'	0,70	1441	205			
18		21	45		0,13	0,25	7°07'	0,67	1605	205			
18		25	38		0,12	0,22	5°35'	0,62	1700	205			
18		29	33		0,10	0,20	5°02'	0,59	1821	205			
17		34	28		0,09	0,18	4°05'	0,54	1830	205			
16		42	23		0,07	0,17	3°22'	0,51	1830	205			
13		50	19		0,05	0,16	3°12'	0,49	1830	205			
14		60	16		0,05	0,15	2°45'	0,45	1830	205			
13		80	12		0,04	0,14	2°07'	0,44	1830	205			
ET040	46	8,0	119	950	0,66	1,0	26°33'	0,86	944	236	2,4	182	
	43	10,5	90		0,49	0,86	19°26'	0,83	1231	308			
	48	12	79		0,49	0,74	14°22'	0,81	1249	312			
	44	16	59		0,34	0,68	14°02'	0,79	1593	360			
	42	21	45		0,27	0,56	10°00'	0,74	1839	360			
	43	25	38		0,24	0,51	8°07'	0,72	1982	360			
	40	32	30		0,18	0,46	7°07'	0,69	2264	360			
	39	42	23		0,15	0,37	5°02'	0,61	2494	360			
	38	50	19		0,13	0,33	4°05'	0,56	2657	360			
	28	62	15		0,09	0,26	3°22'	0,50	2916	360			
	28	80	12		0,07	0,23	2°51'	0,49	3391	360			
	25	100	10		0,05	0,20	2°25'	0,47	3400	360			
	ET050	72	7,25	131	950	1,1	1,6	20°40'	0,87	1354			338
67		9,5	100		0,83	1,4	19°39'	0,84	1756	439			
74		12	79		0,76	1,1	13°14'	0,81	1891	473			
76		14,5	66		0,67	1,0	10°41'	0,79	2085	500			
70		19	50		0,48	0,92	10°07'	0,76	2544	500			
73		25	38		0,40	0,81	8°44'	0,73	2898	500			
74		29	33		0,39	0,64	5°06'	0,66	2896	500			
67		38	25		0,28	0,59	5°23'	0,63	3445	500			
62		50	19		0,21	0,52	4°23'	0,58	3947	500			
60		62	15		0,18	0,46	3°11'	0,52	4237	500			
50		83	11		0,12	0,45	3°22'	0,51	4800	500			
44		100	10		0,10	0,45	2°21'	0,46	4800	500			
ET063		136	7,25	131	950	2,1	3,0	20°36'	0,89	1509	377	6,4	190
	122	9,75	97		1,5	2,4	20°40'	0,86	2197	549			
	114	12,75	75		1,0	2,2	19°39'	0,84	2802	700			
	146	14,5	66		1,2	1,8	10°39'	0,81	2551	638			
	130	19,5	49		0,83	1,6	10°41'	0,79	3367	700			
	119	25,5	37		0,62	1,3	10°07'	0,74	3991	700			
	144	29	33		0,73	1,1	5°22'	0,68	3638	700			
	125	39	24		0,49	0,95	5°23'	0,65	4598	700			
	112	51	19		0,35	0,89	5°06'	0,62	5421	700			
	115	61	16		0,35	0,72	3°16'	0,53	5497	700			
	99	82	12		0,24	0,68	3°11'	0,50	6200	700			
	71	100	10		0,17	0,59	2°12'	0,43	6200	700			



# E Serisi Motorsuz Güç Devir Sayfaları

## E Series Gear Units Performance Tables

### E Serien Getriebe Leistung und Drehzahlübersicht

950



Tipi Type Typ	Anma Momenti	Çevrim Oranı	Çıkış Devri	Giriş Devri	Güç Pe/Pt [kW] (Servis Faktörü fs=1,0 için)Pe=Mekanik Güç / Pt=Termik Güç				Güv. Rad.Yük Çıkış	Güv.Rad.Yük Giriş	Ağırlık	Ölçü Sayfası
	Nominal Torques	Ratio	Output speeds	Input Speeds	Power Pe/Pt [kW] (For Service Factor fs=1,0) Pe=Mechanical Power / Pt=Thermal Power				Per.O.Loads (Output)	Per.O.Loads (Input)	Weight	Dim. Page
	Nenn-drehmomente	Übersetzung	Abtriebs-drehzahl	Antriebs-drehzahl	Leistung Pe/Pt [kW] (Bei Betriebsfaktor fs=1,0) Pe=Mechanische Leistung / Pt=Thermische Leistung				Zul.Querkräfte (Abtrieb)	Zul.Querkräfte (Antrieb)	Gewicht	Maß Seite
	Ma [Nm]	i	n2 [rpm]	n1 [rpm]	Pe [kW]	Pt [kW]	γ	η	Fqam [N]	Fqem [N]	[kg]	
ET075	202	7,5	127	950	3,0	3,9	26°17'	0,88	2690	672	9,2	194
	211	10	95		2,4	3,5	20°20'	0,87	3481	870		
	222	15	63		1,8	2,7	13°52'	0,83	4532	1100		
	218	20	48		1,4	2,2	11°18'	0,79	5439	1100		
	214	25	38		1,1	1,9	9°32'	0,75	6159	1100		
	224	30	32		1,1	1,6	7°3'	0,71	6449	1100		
	212	40	24		0,78	1,4	5°43'	0,67	7000	1100		
	203	50	19		0,64	1,3	4°48'	0,63	7000	1100		
	191	60	16		0,56	1,1	4°8'	0,57	7000	1100		
	176	80	12		0,41	1,0	3°15'	0,54	7000	1100		
	156	100	10		0,32	0,91	2°40'	0,48	7000	1100		
ET080	273	7,5	127	950	4,1	4,6	21°48'	0,89	1874	469	11,0	198
	255	10	95		2,9	4,3	20°36'	0,88	2530	632		
	228	13,25	72		2,0	3,8	20°40'	0,86	3401	850		
	297	15	63		2,4	3,0	11°18'	0,83	3011	753		
	272	20	48		1,7	2,5	10°39'	0,79	3934	983		
	240	26,5	36		1,2	2,2	10°41'	0,76	4924	1100		
	298	30	32		1,4	1,9	5°42'	0,72	4457	1100		
	267	40	24		0,97	1,7	5°22'	0,68	5574	1100		
	230	53	18		0,67	1,5	5°23'	0,65	6765	1100		
	224	62	15		0,62	1,3	3°13'	0,58	6932	1100		
	141	82	12		0,32	1,1	3°16'	0,54	7400	1100		
	98	110	8,6		0,18	1,1	3°11'	0,50	7400	1100		
	ET100	480	7,5	127	950	7,1	8,0	21°48'	0,90	2555	639	31,7
436		10	95		4,9	7,0	21°48'	0,88	3454	864		
405		13	73		3,6	6,0	20°36'	0,87	4483	1121		
528		15	63		4,1	5,6	11°18'	0,86	4067	1017		
474		20	48		2,8	4,8	11°18'	0,83	5512	1300		
431		26	37		2,0	4,1	10°39'	0,80	6691	1300		
538		30	32		2,4	3,3	5°42'	0,75	6050	1300		
472		40	24		1,7	2,7	5°42'	0,71	7679	1300		
419		52	18		1,2	2,4	5°22'	0,67	8200	1300		
457		63	15		1,2	2,1	3°21'	0,63	8200	1300		
296		82	12		0,61	2,0	3°13'	0,59	8200	1300		
183		107	8,9		0,32	1,7	3°16'	0,53	8200	1300		
ET125	863	7,25	131	950	13	14	21°48'	0,91	3486	871	62,2	206
	794	10	95		8,8	12	21°48'	0,90	3714	929		
	718	13	73		6,2	11	21°48'	0,88	5199	1300		
	951	14,5	66		7,6	8,5	11°18'	0,86	4080	1020		
	872	20	48		5,1	8,5	11°18'	0,86	6312	1578		
	776	26	37		3,6	7,1	11°18'	0,83	7974	1800		
	976	29	33		4,4	5,1	5°42'	0,76	6473	1618		
	881	40	24		2,9	5,0	5°42'	0,75	9088	1800		
	767	52	18		2,0	4,5	5°42'	0,73	11112	1800		
	858	62	15		2,1	3,5	3°24'	0,65	10780	1800		
	607	83	11		1,2	3,3	3°22'	0,63	13000	1800		
	386	107	8,9		0,61	3,0	3°13'	0,59	13000	1800		



# E Serisi Motorsuz Güç Devir Sayfaları

## E Series Gear Units Performance Tables

### E Serien Getriebe Leistung und Drehzahlübersicht

**1450**

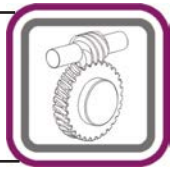

Tipi  Type  Typ	Anma Momenti	Çevrim Oranı	Çıkış Devri	Giriş Devri	Güç Pe/Pt [kW] (Servis Faktörü $f_s=1,0$ için) $P_e$ =Mekanik Güç / $P_t$ =Termik Güç				Güv. Rad.Yük Çıkış	Güv.Rad.Yük Giriş	Ağırlık	Ölçü Sayfası
	Nominal Torques	Ratio	Output speeds	Input Speeds	Power Pe/Pt [kW] (For Service Factor $f_s=1,0$ ) $P_e$ =Mechanical Power / $P_t$ =Thermal Power				Per.O.Loads (Output)	Per.O.Loads (Input)	Weight	Dim. Page
	Nenn-drehmomente	Übersetzung	Abtriebs-drehzahl	Antriebs-drehzahl	Leistung Pe/Pt [kW] (Bei Betriebsfaktor $f_s=1,0$ ) $P_e$ =Mechanische Leistung / $P_t$ =Thermische Leistung				Zul.Querkräfte (Abtrieb)	Zul.Querkräfte (Antrieb)	Gewicht	Maß Seite
	Ma [Nm]	i	n2 [rpm]	n1 [rpm]	Pe [kW]	Pt [kW]	$\gamma$	$\eta$	Fqam [N]	Fqem [N]	[kg]	
<b>ET030</b>	18	5,25	276	<b>1450</b>	0,60	0,71	26°33'	0,88	570	142	1,2	178
	17	7,25	200		0,41	0,57	19°26'	0,86	820	205		
	17	10,5	138		0,30	0,44	14°02'	0,81	1003	205		
	18	14,5	100		0,24	0,35	10°00'	0,77	1162	205		
	18	17	85		0,22	0,31	8°07'	0,73	1228	205		
	17	21	69		0,18	0,27	7°07'	0,70	1369	205		
	18	25	58		0,16	0,24	5°35'	0,65	1449	205		
	17	29	50		0,14	0,22	5°02'	0,62	1553	205		
	17	34	43		0,13	0,19	4°05'	0,58	1632	205		
	16	42	35		0,10	0,18	3°22'	0,55	1805	205		
	14	50	29		0,08	0,18	3°12'	0,53	1830	205		
	10	60	24		0,05	0,16	2°45'	0,48	1830	205		
10	80	18		0,04	0,15	2°07'	0,46	1830	205			
<b>ET040</b>	42	8,0	181	<b>1450</b>	0,91	1,2	26°33'	0,88	784	196	2,4	182
	40	10,5	138		0,69	0,94	19°26'	0,85	1036	259		
	45	12	121		0,68	0,83	14°22'	0,83	1048	262		
	41	16	91		0,48	0,72	14°02'	0,80	1350	337		
	40	21	69		0,38	0,62	10°00'	0,77	1564	360		
	41	25	58		0,33	0,57	8°07'	0,75	1689	360		
	39	32	45		0,26	0,50	7°07'	0,72	1934	360		
	38	42	35		0,22	0,40	5°02'	0,65	2128	360		
	38	50	29		0,19	0,36	4°05'	0,61	2266	360		
	36	62	23		0,16	0,31	3°22'	0,55	2403	360		
	34	80	18		0,12	0,24	2°51'	0,54	2794	360		
	31	100	15		0,09	0,20	2°25'	0,52	3098	360		
<b>ET050</b>	67	7,25	200	<b>1450</b>	1,6	1,9	20°40'	0,88	1127	282	4,1	186
	63	9,5	153		1,2	1,6	19°39'	0,87	1480	370		
	70	12	121		1,1	1,3	13°14'	0,83	1591	398		
	73	14,5	100		0,93	1,2	10°41'	0,82	1761	440		
	67	19	76		0,67	1,1	10°07'	0,80	2162	500		
	71	25	58		0,56	0,92	8°44'	0,77	2466	500		
	74	29	50		0,54	0,74	5°23'	0,71	2454	500		
	67	38	38		0,39	0,67	5°06'	0,68	2933	500		
	62	50	29		0,30	0,57	4°23'	0,62	3368	500		
	62	62	23		0,26	0,52	3°11'	0,59	3617	500		
	51	83	17		0,17	0,47	3°22'	0,55	4301	500		
	48	100	15		0,14	0,43	2°21'	0,50	4621	500		
<b>ET063</b>	125	7,25	200	<b>1450</b>	2,9	3,4	20°37'	0,90	1233	308	6,4	190
	114	9,75	149		2,0	2,6	20°40'	0,87	1832	458		
	107	12,75	114		1,5	2,5	19°39'	0,87	2365	591		
	138	14,5	100		1,7	2,2	10°39'	0,85	2134	534		
	124	19,5	74		1,2	1,9	10°41'	0,83	2852	700		
	115	25,5	57		0,88	1,5	10°08'	0,77	3383	700		
	142	29	50		1,0	1,2	5°22'	0,73	3050	700		
	124	39	37		0,70	1,1	5°23'	0,69	3891	700		
	113	51	28		0,50	1,0	5°06'	0,67	4616	700		
	121	61	24		0,50	0,82	3°16'	0,60	4654	700		
	104	82	18		0,34	0,75	3°11'	0,56	5571	700		
	82	100	15		0,26	0,64	2°26'	0,48	6170	700		





# E Serisi Motorsuz Güç Devir Sayfaları

## E Series Gear Units Performance Tables

### E Serien Getriebe Leistung und Drehzahlübersicht

1450



Tipi Type Typ	Anma Momenti	Çevrim Oranı	Çıkış Devri	Giriş Devri	Güç Pe/Pt [kW] (Servis Faktörü fs=1,0 için)Pe=Mekanik Güç / Pt=Termik Güç				Güv. Rad.Yük Çıkış	Güv.Rad.Yük Giriş	Ağırlık	Ölçü Sayfası
	Nominal Torques	Ratio	Output speeds	Input Speeds	Power Pe/Pt [kW] (For Service Factor fs=1,0) Pe=Mechanical Power / Pt=Thermal Power				Per.O.Loads (Output)	Per.O.Loads (Input)	Weight	Dim. Page
	Nenn-drehmomente	Übersetzung	Abtriebs-drehzahl	Antriebs-drehzahl	Leistung Pe/Pt [kW] (Bei Betriebsfaktor fs=1,0) Pe=Mechanische Leistung / Pt=Thermische Leistung				Zul.Querkräfte (Abtrieb)	Zul.Querkräfte (Antrieb)	Gewicht	Maß Seite
	Ma [Nm]	i	n2 [rpm]	n1 [rpm]	Pe [kW]	Pt [kW]	γ	η	Fqam [N]	Fqem [N]	[kg]	
ET075	186	7,5	193	1450	4,2	4,1	26°17'	0,89	2483	621	9,2	194
	196	10	145		3,4	4,0	20°20'	0,88	2884	721		
	208	15	97		2,5	2,9	13°52'	0,84	3786	947		
	207	20	73		1,9	2,4	11°18'	0,81	4567	1100		
	205	25	58		1,6	2,1	9°32'	0,78	5182	1100		
	219	30	48		1,5	1,8	7°3'	0,74	5409	1100		
	210	40	36		1,1	1,6	5°43'	0,72	6439	1100		
	202	50	29		0,91	1,4	4°48'	0,68	7000	1100		
	196	60	24		0,81	1,2	4°8'	0,61	7000	1100		
	183	80	18		0,58	1,1	3°15'	0,60	7000	1100		
	172	100	15		0,48	1,0	2°40'	0,55	7000	1100		
ET080	249	7,5	193	1450	5,7	4,7	21°48'	0,89	1762	441	11,0	198
	236	10	145		4,0	4,8	20°36'	0,89	2094	523		
	213	13,25	109		2,8	4,2	20°40'	0,88	2859	715		
	276	15	97		3,3	3,2	11°18'	0,84	2491	623		
	259	20	73		2,4	2,8	10°39'	0,81	3293	823		
	230	26,5	55		1,7	2,4	10°41'	0,78	4158	1040		
	285	30	48		1,9	2,0	5°42'	0,75	3727	932		
	264	40	36		1,4	1,9	5°22'	0,73	4703	1100		
	230	53	27		0,95	1,7	5°23'	0,69	5747	1100		
	244	62	23		0,95	1,4	3°13'	0,63	5714	1100		
	158	82	18		0,49	1,3	3°16'	0,60	7370	1100		
	110	110	13		0,27	1,2	3°11'	0,56	7400	1100		
	ET100	434	7,5	193	1450	9,8	7,5	21°48'	0,90	2482	621	31,7
399		10	145		6,8	7,0	21°48'	0,89	2851	713		
375		13	112		5,0	6,3	20°36'	0,88	3750	937		
480		15	97		5,7	5,4	11°18'	0,86	3374	843		
441		20	73		4,0	5,1	11°18'	0,85	4640	1160		
411		26	56		2,9	4,8	10°39'	0,83	5670	1300		
497		30	48		3,3	3,3	5°42'	0,76	5066	1266		
453		40	36		2,4	2,9	5°42'	0,73	6471	1300		
417		52	28		1,7	2,7	5°22'	0,71	7678	1300		
443		63	23		1,6	2,3	3°21'	0,65	7850	1300		
322		82	18		0,93	2,2	3°13'	0,64	8200	1300		
206		107	14		0,49	1,9	3°16'	0,60	8200	1300		
ET125		796	7,25	200	1450	18	17	21°48'	0,93	3266	816	62,2
	720	10	145		12	11	21°48'	0,90	3172	793		
	658	13	112		8,7	11	21°48'	0,89	4328	1082		
	864	14,5	100		11	8,3	11°18'	0,86	3313	828		
	795	20	73		7,1	8,3	11°18'	0,86	5283	1321		
	724	26	56		5,0	7,6	11°18'	0,84	6733	1683		
	894	29	50		6,2	5,0	5°42'	0,76	5346	1336		
	817	40	36		4,1	5,0	5°42'	0,76	7653	1800		
	740	52	28		2,8	5,0	5°42'	0,76	9433	1800		
	797	62	23		3,0	3,5	3°24'	0,65	9057	1800		
	632	83	17		1,8	3,4	3°22'	0,65	11796	1800		
	420	107	14		0,93	3,3	3°13'	0,64	13000	1800		



# E Serisi Motorsuz Güç Devir Sayfaları

## E Series Gear Units Performance Tables

### E Serien Getriebe Leistung und Drehzahlübersicht

**2900**

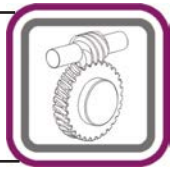

Tipi Type Typ	Anma Momenti	Çevrim Oranı	Çıkış Devri	Giriş Devri	Güç Pe/Pt [kW] (Servis Faktörü $f_s=1,0$ için) $P_e$ =Mekanik Güç / $P_t$ =Termik Güç				Güv. Rad.Yük Çıkış	Güv.Rad.Yük Giriş	Ağırlık	Ölçü Sayfası
	Nominal Torques	Ratio	Output speeds	Input Speeds	Power $P_e/P_t$ [kW] (For Service Factor $f_s=1,0$ ) $P_e$ =Mechanical Power / $P_t$ =Thermal Power				Per.O.Loads (Output)	Per.O.Loads (Input)	Weight	Dim. Page
	Nenn-drehmomente	Übersetzung	Abtriebs-drehzahl	Antriebs-drehzahl	Leistung $P_e/P_t$ [kW] (Bei Betriebsfaktor $f_s=1,0$ ) $P_e$ =Mechanische Leistung / $P_t$ =Thermische Leistung				Zul.Querkräfte (Abtrieb)	Zul.Querkräfte (Antrieb)	Gewicht	Maß Seite
	Ma [Nm]	i	n2 [rpm]	n1 [rpm]	Pe [kW]	Pt [kW]	$\gamma$	$\eta$	Fqam [N]	Fqem [N]	[kg]	
<b>ET030</b>	16	5,25	552	<b>2900</b>	1,0	0,87	26°33'	0,91	458	114	1,2	178
	15	7,25	400		0,69	0,70	19°26'	0,89	625	156		
	15	10,5	276		0,51	0,54	14°02'	0,86	769	192		
	16	14,5	200		0,42	0,42	10°00'	0,82	894	205		
	17	17	171		0,38	0,37	8°07'	0,79	943	205		
	16	21	138		0,31	0,32	7°07'	0,76	1055	205		
	17	25	116		0,28	0,28	5°35'	0,72	1115	205		
	17	29	100		0,25	0,26	5°02'	0,70	1196	205		
	17	34	85		0,23	0,22	4°05'	0,65	1254	205		
	16	42	69		0,18	0,22	3°25'	0,65	1399	205		
	15	50	58		0,15	0,21	3°12'	0,63	1542	205		
	12	60	48		0,10	0,19	2°45'	0,59	1738	205		
	12	80	36		0,08	0,18	2°07'	0,56	1830	205		
<b>ET040</b>	37	8,0	363	<b>2900</b>	1,6	1,4	26°33'	0,90	680	170	2,4	182
	36	10,5	276		1,2	1,1	19°26'	0,88	778	195		
	39	12	242		1,2	0,92	14°22'	0,85	782	196		
	37	16	181		0,83	0,84	14°02'	0,84	1026	256		
	37	21	138		0,65	0,75	10°00'	0,82	1198	300		
	38	25	116		0,56	0,73	8°07'	0,82	1302	325		
	37	32	91		0,44	0,65	7°07'	0,79	1497	360		
	38	42	69		0,37	0,51	5°02'	0,74	1645	360		
	38	50	58		0,33	0,44	4°05'	0,69	1750	360		
	31	62	47		0,23	0,33	3°22'	0,59	1683	360		
	28	80	36		0,18	0,29	2°51'	0,58	2226	360		
	25	100	29		0,14	0,24	2°25'	0,55	2474	360		
	<b>ET050</b>	57	7,25	400	<b>2900</b>	2,7	1,8	20°4'	0,89	829	207	4,1
54		9,5	305		2,0	1,6	19°39'	0,87	1114	278		
60		12	242		1,8	1,3	13°14'	0,84	1194	299		
63		14,5	200		1,6	1,2	14°41'	0,83	1332	333		
59		19	153		1,2	1,1	10°07'	0,82	1655	414		
63		25	116		0,97	1,0	8°44'	0,80	1892	473		
65		29	100		0,94	0,76	5°06'	0,73	1871	468		
61		38	76		0,68	0,72	5°23'	0,71	2255	500		
59		50	58		0,53	0,64	4°23'	0,68	2597	500		
59		62	47		0,45	0,57	3°11'	0,64	2797	500		
53		83	35		0,30	0,59	3°22'	0,65	3350	500		
50		100	29		0,26	0,44	2°21'	0,59	3580	500		
<b>ET063</b>	104	7,25	414	<b>2900</b>	4,9	3,9	20°36'	0,92	1102	276	6,4	190
	94	9,75	308		3,5	2,5	20°40'	0,87	1349	337		
	89	12,75	235		2,5	2,5	19°39'	0,87	1787	447		
	117	14,5	207		2,9	2,5	10°39'	0,88	1591	398		
	104	19,5	154		2,0	2,0	10°41'	0,84	2173	543		
	98	25,5	118		1,5	1,4	10°07'	0,78	2573	643		
	125	29	103		1,8	1,3	5°22'	0,76	2280	570		
	107	39	77		1,2	1,1	5°23'	0,70	2956	700		
	100	51	59		0,88	1,1	5°06'	0,70	3546	700		
	106	61	49		0,89	0,82	3°16'	0,61	3542	700		
	96	82	37		0,62	0,78	3°11'	0,59	4274	700		
	87	100	30		0,52	0,66	2°12'	0,52	4603	700		



# E Serisi Motorsuz Güç Devir Sayfaları

## E Series Gear Units Performance Tables

### E Serien Getriebe Leistung und Drehzahlübersicht

2900



Tipi Type Typ	Anma Momenti	Çevrim Oranı	Çıkış Devri	Giriş Devri	Güç Pe/Pt [kW] (Servis Faktörü fs=1,0 için)Pe=Mekanik Güç / Pt=Termik Güç				Güv. Rad.Yük Çıkış	Güv.Rad.Yük Giriş	Ağırlık	Ölçü Sayfası
	Nominal Torques	Ratio	Output speeds	Input Speeds	Power Pe/Pt [kW] (For Service Factor fs=1,0) Pe=Mechanical Power / Pt=Thermal Power				Per.O.Loads (Output)	Per.O.Loads (Input)	Weight	Dim. Page
	Nenn-drehmomente	Übersetzung	Abtriebs-drehzahl	Antriebs-drehzahl	Leistung Pe/Pt [kW] (Bei Betriebsfaktor fs=1,0) Pe=Mechanische Leistung / Pt=Thermische Leistung				Zul.Querkräfte (Abtrieb)	Zul.Querkräfte (Antrieb)	Gewicht	Maß Seite
	Ma [Nm]	i	n2 [rpm]	n1 [rpm]	Pe [kW]	Pt [kW]	$\gamma$	$\eta$	Fqam [N]	Fqem [N]	[kg]	
ET075	160	7,5	387	2900	7,3	3,9	26°17'	0,89	2269	567	9,2	194
	169	10	290		5,8	4,0	20°20'	0,89	2101	525		
	177	15	193		4,3	2,6	13°52'	0,83	2802	701		
	178	20	145		3,4	2,2	11°18'	0,80	3411	853		
	178	25	116		2,8	1,9	9°32'	0,77	3886	971		
	188	30	97		2,6	1,6	7°30'	0,73	4032	1008		
	185	40	73		1,9	1,6	5°43'	0,73	4886	1100		
	181	50	58		1,6	1,4	4°48'	0,69	5454	1100		
	177	60	48		1,5	1,1	4°8'	0,61	5773	1100		
	169	80	36		1,0	1,2	3°15'	0,62	6852	1100		
162	100	29		0,86	1,0	2°40'	0,57	7000	1100			
ET080	215	7,5	387	2900	9,7	4,7	21°48'	0,89	1611	403	11,0	198
	204	10	290		6,8	5,1	20°36'	0,90	1524	381		
	182	13,25	219		4,8	3,9	20°40'	0,87	2142	536		
	242	15	193		5,7	3,5	11°18'	0,86	1816	454		
	228	20	145		4,2	2,8	10°39'	0,83	2446	612		
	201	26,5	109		3,0	2,2	10°41'	0,78	3138	785		
	259	30	97		3,3	2,3	5°42'	0,78	2777	694		
	242	40	73		2,4	2,1	5°22'	0,76	3559	890		
	207	53	55		1,7	1,7	5°23'	0,71	4397	1099		
	244	62	47		1,7	1,6	3°13'	0,69	4239	1060		
	165	82	35		0,99	1,3	3°16'	0,62	5544	1100		
	119	110	26		0,55	1,2	3°11'	0,60	6702	1100		
ET100	374	7,5	387	2900	17	7,9	21°48'	0,90	2190	547	31,7	202
	345	10	290		12	7,1	21°48'	0,89	2206	552		
	325	13	223		8,6	6,2	20°36'	0,88	2780	695		
	422	15	193		9,7	6,4	11°18'	0,88	2479	620		
	388	20	145		6,8	5,7	11°18'	0,87	3496	874		
	363	26	112		5,0	5,2	10°39'	0,86	4322	1080		
	451	30	97		5,7	3,9	5°42'	0,81	3795	949		
	413	40	73		4,1	3,1	5°42'	0,76	4881	1220		
	384	52	56		3,1	2,8	5°22'	0,73	5838	1300		
	420	63	46		2,9	2,6	3°21'	0,71	5981	1300		
	352	82	35		1,9	2,5	3°13'	0,70	7393	1300		
	215	107	27		0,99	2,0	3°16'	0,61	8200	1300		
ET125	686	7,25	400	2900	30	22	21°48'	0,95	2020	505	62,2	206
	621	10	290		21	12	21°48'	0,90	2800	700		
	569	13	223		15	11	21°48'	0,89	3183	796		
	758	14,5	200		18	9,9	11°18'	0,88	2340	585		
	699	20	145		12	9,8	11°18'	0,88	3947	987		
	639	26	112		8,7	8,4	11°18'	0,86	5101	1275		
	811	29	100		11	5,9	5°42'	0,81	3911	978		
	745	40	73		7,0	5,9	5°42'	0,81	5790	1447		
	679	52	56		4,9	5,9	5°42'	0,81	7231	1800		
	756	62	47		5,2	4,0	3°24'	0,71	6831	1708		
	689	83	35		3,5	4,0	3°22'	0,71	8672	1800		
	459	107	27		1,9	3,8	3°13'	0,70	10964	1800		

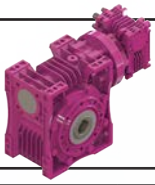

# E Serisi Motorsuz Güç Devir Sayfaları

## E Series Gear Units Performance Tables

### E Serien Getriebe Leistung und Drehzahlübersicht

**1450**

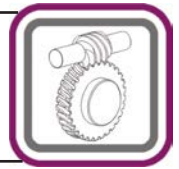

Tipi  Type  Typ	Anma Momenti	Çevrim Oranı	Çıkış Devri	Giriş Devri	Güç Pe/Pt [kW] (Servis Faktörü fs=1,0 için)Pe=Mekanik Güç / Pt=Termik Güç				Güv. Rad.Yük Çıkış	Güv.Rad.Yük Giriş	Ağırlık	Ölçü Sayfası
	Nominal Torques	Ratio	Output speeds	Input Speeds	Power Pe/Pt [kW] (For Service Factor fs=1,0) Pe=Mechanical Power / Pt=Thermal Power				Per.O.Loads (Output)	Per.O.Loads (Input)	Weight	Dim. Page
	Nenn-drehmomente	Über-setzung	Abtriebs-drehzahl	Antriebs-drehzahl	Leistung Pe/Pt [kW] (Bei Betriebsfaktor fs=1,0) Pe=Mechanische Leistung / Pt=Thermische Leistung				Zul.Querkräfte (Abtrieb)	Zul.Querkräfte (Antrieb)	Gewicht	Maß Seite
	Ma [Nm]	i	n2 [rpm]	n1 [rpm]	Pe [kW]	Pt [kW]	γ	η	Fqam [N]	Fqem [N]	[kg]	
<b>ET040-030</b>	<b>61</b>	84	17	<b>1450</b>	0,17	-	14°02'	0,63	3400	205	4,9	210
	<b>64</b>	116	13		0,14	-	10°00'	0,59	3400	205		
	<b>65</b>	136	11		0,13	-	8°07'	0,57	3400	205		
	<b>67</b>	168	8,6		0,11	-	7°07'	0,54	3400	205		
	<b>69</b>	200	7,3		0,10	-	5°35'	0,51	3400	205		
	<b>60</b>	232	6,3		0,10	-	5°02'	0,41	3400	205		
	<b>61</b>	272	5,3		0,09	-	4°05'	0,38	3400	205		
	<b>62</b>	336	4,3		0,08	-	3°22'	0,36	3400	205		
	<b>63</b>	400	3,6		0,07	-	3°12'	0,35	3400	205		
	<b>64</b>	480	3,0		0,06	-	2°45'	0,32	3400	205		
	<b>47</b>	544	2,7		0,04	-	4°05'	0,32	3400	205		
	<b>48</b>	672	2,2		0,04	-	3°22'	0,30	3400	205		
	<b>48</b>	800	1,8		0,03	-	3°12'	0,29	3400	205		
	<b>48</b>	960	1,5		0,03	-	2°45'	0,26	3400	205		
	<b>32</b>	1088	1,3		0,02	-	4°05'	0,22	3400	205		
	<b>32</b>	1344	1,1		0,02	-	3°22'	0,21	3400	205		
	<b>32</b>	1600	0,91		0,01	-	3°12'	0,20	3400	205		
	<b>32</b>	1920	0,76		0,01	-	2°45'	0,19	3400	205		
	<b>27</b>	2520	0,58		0,01	-	2°45'	0,15	3400	205		
	<b>23</b>	3000	0,48		0,01	-	2°45'	0,12	3400	205		
<b>22</b>	3720	0,39		0,01	-	2°45'	0,09	3400	205			
<b>ET050-030</b>	<b>89</b>	137,75	11	<b>1450</b>	0,17	-	10°00'	0,56	4800	205	5,7	211
	<b>90</b>	174	8,3		0,16	-	10°00'	0,51	4800	205		
	<b>88</b>	210,25	6,9		0,13	-	10°00'	0,47	4800	205		
	<b>90</b>	246,5	5,9		0,12	-	8°07'	0,45	4800	205		
	<b>92</b>	304,5	4,8		0,11	-	7°07'	0,43	4800	205		
	<b>93</b>	362,5	4,0		0,10	-	5°35'	0,40	4800	205		
	<b>94</b>	420,5	3,4		0,09	-	5°02'	0,38	4800	205		
	<b>95</b>	493	2,9		0,08	-	4°05'	0,36	4800	205		
	<b>76</b>	609	2,4		0,07	-	3°22'	0,26	4800	205		
	<b>76</b>	725	2,0		0,06	-	3°12'	0,26	4800	205		
	<b>77</b>	870	1,7		0,06	-	2°45'	0,23	4800	205		
	<b>72</b>	986	1,5		0,04	-	4°05'	0,26	4800	205		
	<b>51</b>	1218	1,2		0,04	-	3°22'	0,17	4800	205		
	<b>51</b>	1450	1,0		0,03	-	3°12'	0,17	4800	205		
	<b>52</b>	1740	0,83		0,03	-	2°45'	0,15	4800	205		
	<b>66</b>	2280	0,64		0,03	-	2°45'	0,15	4800	205		
	<b>51</b>	3000	0,48		0,02	-	2°45'	0,13	4800	205		
	<b>48</b>	3720	0,39		0,02	-	2°45'	0,10	4800	205		
	<b>67</b>	4980	0,29		0,02	-	2°45'	0,10	4800	205		
	<b>ET063-030</b>	<b>144</b>	210,25	6,9	<b>1450</b>	0,23	-	5°22'	0,46	6200	205	8,0
<b>124</b>		304,5	4,8		0,17	-	5°22'	0,36	6200	205		
<b>127</b>		420,5	3,4		0,13	-	5°22'	0,34	6200	205		
<b>129</b>		493	2,9		0,12	-	5°22'	0,33	6200	205		
<b>131</b>		609	2,4		0,11	-	5°22'	0,31	6200	205		
<b>132</b>		725	2,0		0,09	-	5°22'	0,29	6200	205		
<b>133</b>		841	1,7		0,09	-	5°02'	0,28	6200	205		
<b>134</b>		986	1,5		0,08	-	4°05'	0,26	6200	205		
<b>135</b>		1218	1,2		0,07	-	3°22'	0,24	6200	205		
<b>135</b>		1450	1,0		0,06	-	3°12'	0,24	6200	205		
<b>96</b>		1740	0,83		0,05	-	2°45'	0,15	6200	205		
<b>117</b>		2340	0,62		0,05	-	2°45'	0,15	6200	205		
<b>117</b>		3060	0,47		0,04	-	2°45'	0,15	6200	205		
<b>96</b>		3660	0,40		0,04	-	2°45'	0,10	6200	205		
<b>94</b>		4920	0,29		0,03	-	2°45'	0,10	6200	205		

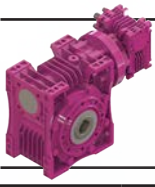

# E Serisi Motorsuz Güç Devir Sayfaları

## E Series Gear Units Performance Tables

### E Serien Getriebe Leistung und Drehzahlübersicht

**1450**

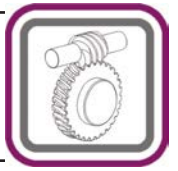

Tipi Type Typ	Anma Momenti	Çevrim Oranı	Çıkış Devri	Giriş Devri	Güç Pe/Pt [kW] (Servis Faktörü fs=1,0 için)Pe=Mekanik Güç / Pt=Termik Güç				Güv. Rad.Yük Çıkış	Güv.Rad.Yük Giriş	Ağırlık	Ölçü Sayfası
	Nominal Torques	Ratio	Output speeds	Input Speeds	Power Pe/Pt [kW] (For Service Factor fs=1,0) Pe=Mechanical Power / Pt=Thermal Power				Per.O.Loads (Output)	Per.O.Loads (Input)	Weight	Dim. Page
	Nenn-drehmomente	Über-setzung	Abtriebs-drehzahl	Antriebs-drehzahl	Leistung Pe/Pt [kW] (Bei Betriebsfaktor fs=1,0) Pe=Mechanische Leistung / Pt=Thermische Leistung				Zul.Querkräfte (Abtrieb)	Zul.Querkräfte (Antrieb)	Gewicht	Maß Seite
	Ma [Nm]	i	n2 [rpm]	n1 [rpm]	Pe [kW]	Pt [kW]	γ	η	Fqam [N]	Fqem [N]	[kg]	
<b>ET075-040</b>	<b>255</b>	180	8,1	<b>1450</b>	0,39	-	13°52'	0,55	7000	360	12,0	213
	<b>264</b>	240	6,0		0,31	-	13°52'	0,54	7000	360		
	<b>271</b>	315	4,6		0,25	-	10°00'	0,52	7000	360		
	<b>275</b>	375	3,9		0,22	-	8°07'	0,50	7000	360		
	<b>281</b>	480	3,0		0,18	-	7°07'	0,48	7000	360		
	<b>285</b>	630	2,3		0,16	-	5°02'	0,43	7000	360		
	<b>233</b>	750	1,9		0,14	-	4°05'	0,33	7000	360		
	<b>235</b>	930	1,6		0,20	-	3°22'	0,20	7000	360		
	<b>225</b>	1260	1,2		0,08	-	5°02'	0,33	7000	360		
	<b>167</b>	1500	0,97		0,07	-	4°05'	0,23	7000	360		
	<b>168</b>	1860	0,78		0,10	-	3°22'	0,14	7000	360		
	<b>140</b>	2480	0,58		0,07	-	3°22'	0,12	7000	360		
	<b>120</b>	3100	0,47		0,06	-	3°22'	0,10	7000	360		
	<b>104</b>	3720	0,39		0,05	-	3°22'	0,09	7000	360		
	<b>96</b>	4960	0,29		0,04	-	3°14'	0,07	7000	360		
	<b>98</b>	6200	0,23		0,04	-	2°40'	0,06	7000	360		
<b>ET080-040</b>	<b>365</b>	180	8,1	<b>1450</b>	0,53	-	11°18'	0,59	7400	360	14,0	214
	<b>335</b>	240	6,0		0,42	-	11°18'	0,50	7400	360		
	<b>344</b>	315	4,6		0,34	-	10°00'	0,48	7400	360		
	<b>349</b>	375	3,9		0,30	-	8°07'	0,47	7400	360		
	<b>356</b>	480	3,0		0,25	-	7°07'	0,45	7400	360		
	<b>362</b>	630	2,3		0,22	-	5°02'	0,41	7400	360		
	<b>365</b>	750	1,9		0,19	-	4°05'	0,38	7400	360		
	<b>291</b>	930	1,6		0,27	-	3°22'	0,18	7400	360		
	<b>274</b>	1260	1,2		0,11	-	5°02'	0,30	7400	360		
	<b>275</b>	1500	0,97		0,10	-	4°05'	0,28	7400	360		
	<b>197</b>	1860	0,78		0,14	-	3°22'	0,12	7400	360		
	<b>168</b>	2480	0,58		0,09	-	3°22'	0,11	7400	360		
	<b>144</b>	3286	0,44		0,06	-	3°22'	0,11	7400	360		
	<b>77</b>	3844	0,38		0,04	-	3°13'	0,07	7400	360		
	<b>99</b>	5084	0,29		0,04	-	3°16'	0,07	7400	360		
	<b>ET100-050</b>	<b>636</b>	180	8,1	<b>1450</b>	0,91	-	11°18'	0,59	8200	500	36,8
<b>651</b>		217,5	6,7		0,78	-	10°41'	0,58	8200	500		
<b>593</b>		285	5,1		0,63	-	10°07'	0,50	8200	500		
<b>608</b>		375	3,9		0,51	-	8°44'	0,48	8200	500		
<b>615</b>		435	3,3		0,48	-	5°23'	0,45	8200	500		
<b>626</b>		570	2,5		0,39	-	5°06'	0,43	8200	500		
<b>636</b>		750	1,9		0,33	-	4°23'	0,39	8200	500		
<b>642</b>		930	1,6		0,28	-	3°11'	0,37	8200	500		
<b>440</b>		1240	1,2		0,18	-	3°11'	0,29	8200	500		
<b>381</b>		1612	0,90		0,13	-	3°11'	0,28	8200	500		
<b>482</b>		1860	0,78		0,14	-	3°11'	0,27	8200	500		
<b>296</b>		2480	0,58		0,09	-	3°11'	0,19	8200	500		
<b>252</b>		3224	0,45		0,06	-	3°11'	0,18	8200	500		
<b>242</b>		3906	0,37		0,05	-	3°11'	0,19	8200	500		
<b>200</b>		5084	0,29		0,05	-	3°11'	0,12	8200	500		
<b>ET125-063</b>		<b>1158</b>	184,875	7,8	<b>1450</b>	1,5	-	11°18'	0,62	13000	700	70,0
	<b>1175</b>	210,25	6,9		1,4	-	10°39'	0,60	13000	700		
	<b>1213</b>	282,75	5,1		1,1	-	10°41'	0,59	13000	700		
	<b>1101</b>	369,75	3,9		0,93	-	10°07'	0,49	13000	700		
	<b>1112</b>	420,5	3,4		0,88	-	5°22'	0,46	13000	700		
	<b>1135</b>	565,5	2,6		0,70	-	5°23'	0,44	13000	700		

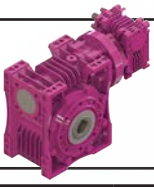

# E Serisi Motorsuz Güç Devir Sayfaları

## E Series Gear Units Performance Tables

### E Serien Getriebe Leistung und Drehzahlübersicht

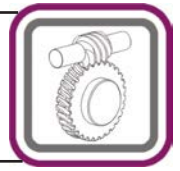
**1450**

Tipi Type Typ	Anma Momenti	Çevrim Oranı	Çıkış Devri	Giriş Devri	Güç Pe/Pt [kW] (Servis Faktörü fs=1,0 için)Pe=Mekanik Güç / Pt=Termik Güç				Güv. Rad.Yük Çıkış	Güv.Rad.Yük Giriş	Ağırlık	Ölçü Sayfası
	Nominal Torques	Ratio	Output speeds	Input Speeds	Power Pe/Pt [kW] (For Service Factor fs=1,0) Pe=Mechanical Power / Pt=Thermal Power				Per.O.Loads (Output)	Per.O.Loads (Input)	Weight	Dim. Page
	Nenn-drehmomente	Über-setzung	Abtriebs-drehzahl	Antriebs-drehzahl	Leistung Pe/Pt [kW] (Bei Betriebsfaktor fs=1,0) Pe=Mechanische Leistung / Pt=Thermische Leistung				Zul.Querkräfte (Abtrieb)	Zul.Querkräfte (Antrieb)	Gewicht	Maß Seite
	Ma [Nm]	i	n2 [rpm]	n1 [rpm]	Pe [kW]	Pt [kW]	$\gamma$	$\eta$	Fqam [N]	Fqem [N]	[kg]	
<b>ET125-063</b>	<b>1152</b>	739,5	2,0	<b>1450</b>	0,56	-	5°06'	0,42	13000	700	70,0	216
	<b>1161</b>	884,5	1,6		0,53	-	3°16'	0,38	13000	700		
	<b>1174</b>	1189	1,2		0,43	-	3°11'	0,35	13000	700		
	<b>801</b>	1640	0,88		0,27	-	3°11'	0,28	13000	700		
	<b>691</b>	2132	0,68		0,18	-	3°11'	0,28	13000	700		
	<b>878</b>	2378	0,61		0,22	-	3°11'	0,26	13000	700		
	<b>536</b>	3280	0,44		0,14	-	3°11'	0,18	13000	700		
	<b>462</b>	4264	0,34		0,09	-	3°11'	0,18	13000	700		
	<b>312</b>	5084	0,29		0,08	-	3°11'	0,12	13000	700		

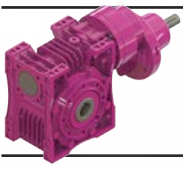

# E Serisi Motorsuz Güç Devir Sayfaları

## E Series Gear Units Performance Tables

### E Serien Getriebe Leistung und Drehzahlübersicht

**1450**



Tipi  Type  Typ	Anma Momenti	Çevrim Oranı	Çıkış Devri	Giriş Devri	Güç Pe/Pt [kW] (Servis Faktörü fs=1,0 için)Pe=Mekanik Güç / Pt=Termik Güç				Güv. Rad.Yük Çıkış	Güv.Rad.Yük Giriş	Ağırlık	Ölçü Sayfası
	Nominal Torques	Ratio	Output speeds	Input Speeds	Power Pe/Pt [kW] (For Service Factor fs=1,0) Pe=Mechanical Power / Pt=Thermal Power				Per.O.Loads (Output)	Per.O.Loads (Input)	Weight	Dim. Page
	Nenn-drehmomente	Über- setzung	Abtriebs- drehzahl	Antriebs- drehzahl	Leistung Pe/Pt [kW] (Bei Betriebsfaktor fs=1,0) Pe=Mechanische Leistung / Pt=Thermische Leistung				Zul.Querkräfte (Abtrieb)	Zul.Querkräfte (Antrieb)	Gewicht	Maß Seite
	Ma [Nm]	i	n2 [rpm]	n1 [rpm]	Pe [kW]	Pt [kW]	γ	η	Fqam [N]	Fqem [N]	[kg]	
<b>EN050-NT01</b>	<b>36</b>	498	2,9	<b>1450</b>	0,03	-	3°22'	0,32	4800	350	7,1	217
	<b>55</b>	372	3,9		0,06	-	3°11'	0,40	4800	350		
	<b>62</b>	300	4,8		0,07	-	4°23'	0,47	4800	350		
	<b>68</b>	228	6,4		0,09	-	5°23'	0,51	4800	350		
	<b>76</b>	174	8,3		0,13	-	5°23'	0,53	4800	350		
	<b>82</b>	150	9,7		0,13	-	8°44'	0,64	4800	350		
	<b>81</b>	114	13		0,16	-	10°07'	0,67	4800	350		
	<b>88</b>	87	17		0,23	-	10°41'	0,68	4800	350		
<b>EN063-NT01</b>	<b>53</b>	600	2,4	<b>1450</b>	0,04	-	2°12'	0,32	6200	350	9,4	218
	<b>89</b>	492	2,9		0,07	-	3°11'	0,39	6200	350		
	<b>103</b>	366	4,0		0,11	-	3°16'	0,40	6200	350		
	<b>111</b>	306	4,7		0,11	-	5°06'	0,51	6200	350		
	<b>125</b>	234	6,2		0,16	-	5°23'	0,52	6200	350		
	<b>141</b>	174	8,3		0,23	-	5°22'	0,52	6200	350		
	<b>134</b>	153	9,5		0,20	-	10°07'	0,66	6200	350		
	<b>147</b>	117	12		0,28	-	10°41'	0,68	6200	350		
<b>EN075-NT11</b>	<b>113</b>	745	1,9	<b>1450</b>	0,07	-	2°40'	0,35	7000	450	13,5	219
	<b>155</b>	596	2,4		0,10	-	3°14'	0,40	7000	450		
	<b>180</b>	447	3,2		0,14	-	4°08'	0,45	7000	450		
	<b>196</b>	372,5	3,9		0,16	-	4°48'	0,50	7000	450		
	<b>214</b>	298	4,9		0,20	-	5°42'	0,54	7000	450		
	<b>237</b>	223,5	6,5		0,28	-	7°02'	0,58	7000	450		
	<b>240</b>	186,25	7,8		0,30	-	9°32'	0,65	7000	450		
	<b>252</b>	149	9,7		0,38	-	11°18'	0,68	7000	450		
	<b>265</b>	111,75	13		0,50	-	13°52'	0,72	7000	450		
	<b>EN080-NT11</b>	<b>59</b>	819,5	1,8	<b>1450</b>	0,04	-	3°11'	0,30	7400	450	15,5
<b>106</b>		610,9	2,4		0,07	-	3°16'	0,40	7400	450		
<b>155</b>		461,9	3,1		0,13	-	3°13'	0,40	7400	450		
<b>228</b>		394,85	3,7		0,17	-	5°23'	0,52	7400	450		
<b>261</b>		298	4,9		0,25	-	5°22'	0,53	7400	450		
<b>294</b>		223,5	6,5		0,37	-	5°42'	0,54	7400	450		
<b>274</b>		197,43	7,3		0,31	-	10°39'	0,67	7400	450		
<b>311</b>		149	9,7		0,47	-	11°18'	0,67	7400	450		
<b>342</b>		111,75	13		0,67	-	11°18'	0,69	7400	450		
<b>EN100-NT11</b>		<b>138</b>	797,15	1,8	<b>1450</b>	0,07	-	3°16'	0,40	7400	450	36,2
	<b>205</b>	610,9	2,4		0,13	-	3°13'	0,40	7400	450		
	<b>310</b>	469,35	3,1		0,24	-	3°21'	0,41	7400	450		
	<b>399</b>	387,4	3,7		0,30	-	5°22'	0,52	7400	450		
	<b>453</b>	298	4,9		0,43	-	5°40'	0,54	7400	450		
	<b>554</b>	223,5	6,5		0,64	-	5°42'	0,59	7400	450		
	<b>481</b>	193,7	7,5		0,55	-	10°39'	0,68	7400	450		
	<b>533</b>	149	9,7		0,78	-	11°18'	0,69	7400	450		
<b>EN125-NT21</b>	<b>299</b>	516,81	2,8	<b>1450</b>	0,20	-	3°13'	0,45	13000	500	68,5	222
	<b>470</b>	400,89	3,6		0,37	-	3°22'	0,47	13000	500		
	<b>745</b>	299,46	4,8		0,75	-	5°42'	0,50	13000	500		
	<b>764</b>	251,16	5,8		0,76	-	5°42'	0,61	13000	500		
	<b>885</b>	193,2	7,5		1,1	-	5°42'	0,62	13000	500		
	<b>1017</b>	140,07	10		1,7	-	11°18'	0,64	13000	500		
	<b>860</b>	125,58	12		1,4	-	11°18'	0,74	13000	500		

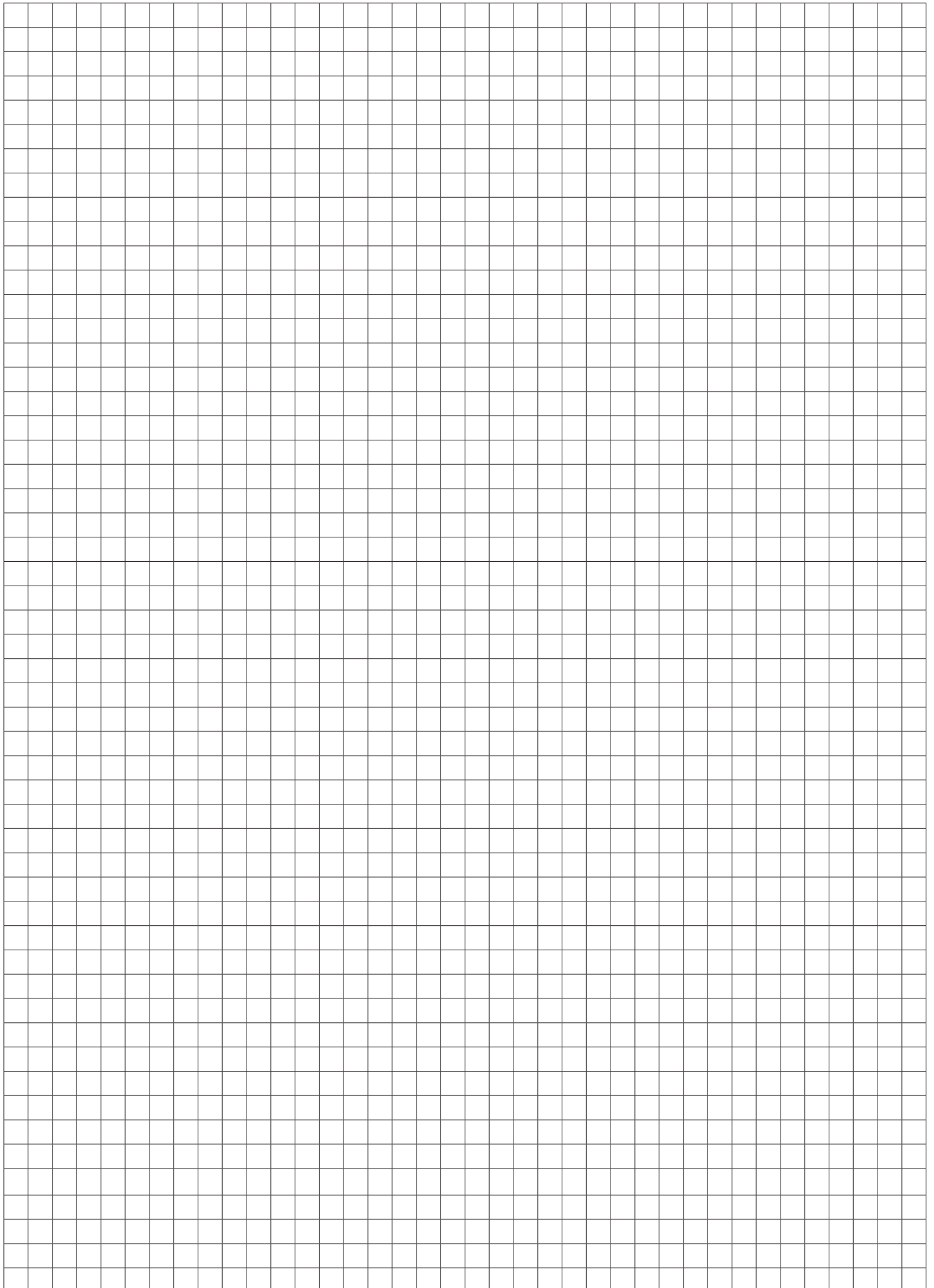





# Ölçü Tabloları

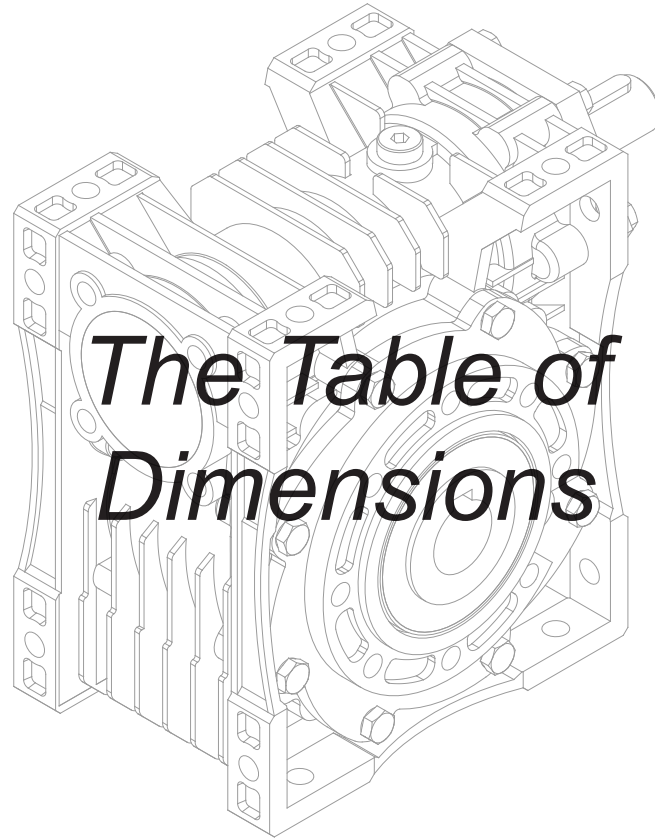

Abmessungs-tabellen

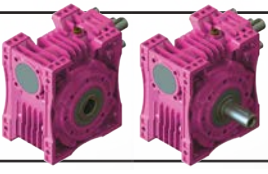

# Ölçü Sayfaları

## Dimension Pages

### Abmessungsseiten

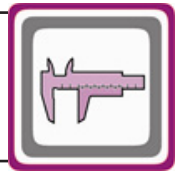

-Mil ucu çekirme deliği DIN 332 sayfa 2 / Tapped center hole to DIN 332, sheet 2 / Zentrierung mit Gewinde DIN 332, Blatt 2

#### ET030.00

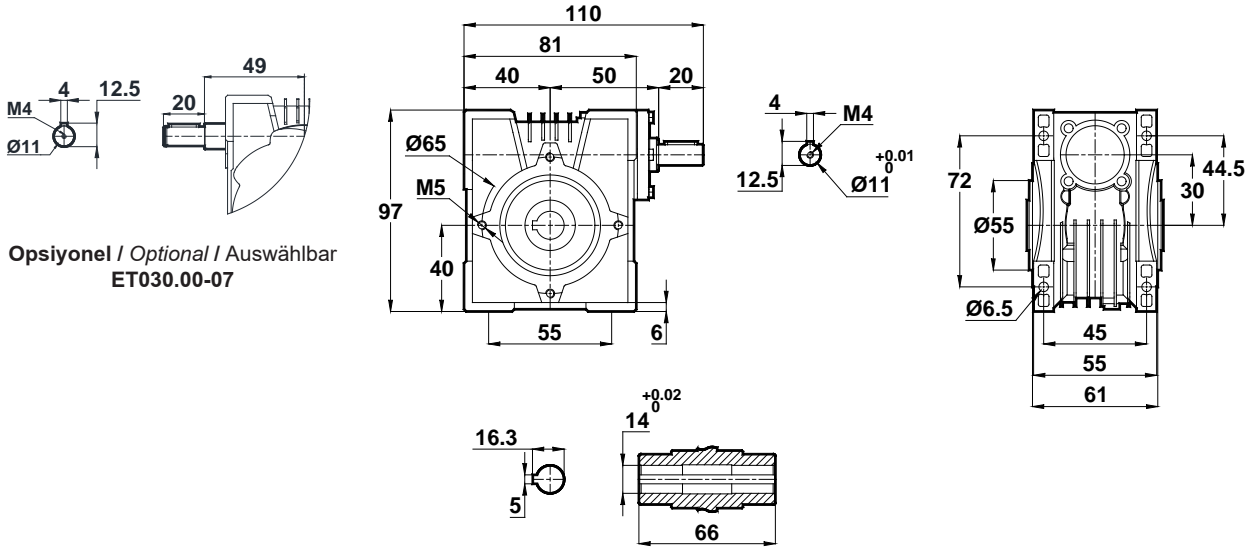

#### ET030.01

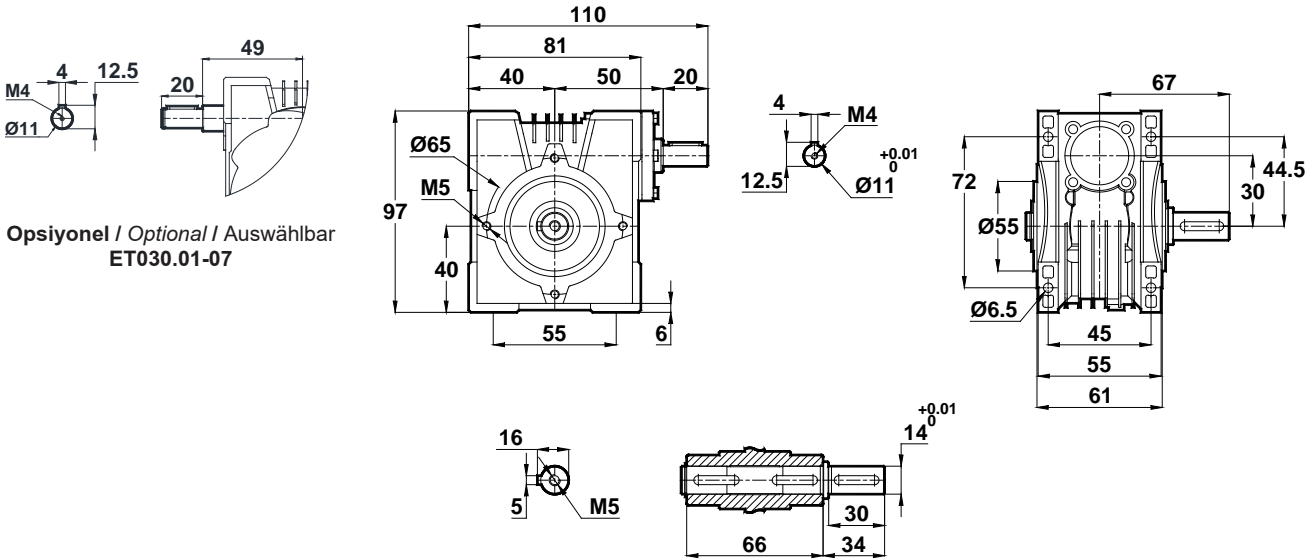

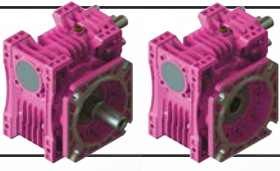

# Ölçü Sayfaları

## Dimension Pages

### Abmessungsseiten



-Mil ucu çekirme deliği DIN 332 sayfa 2 / Tapped center hole to DIN 332, sheet 2 / Zentrierung mit Gewinde DIN 332, Blatt 2

#### ET030.02

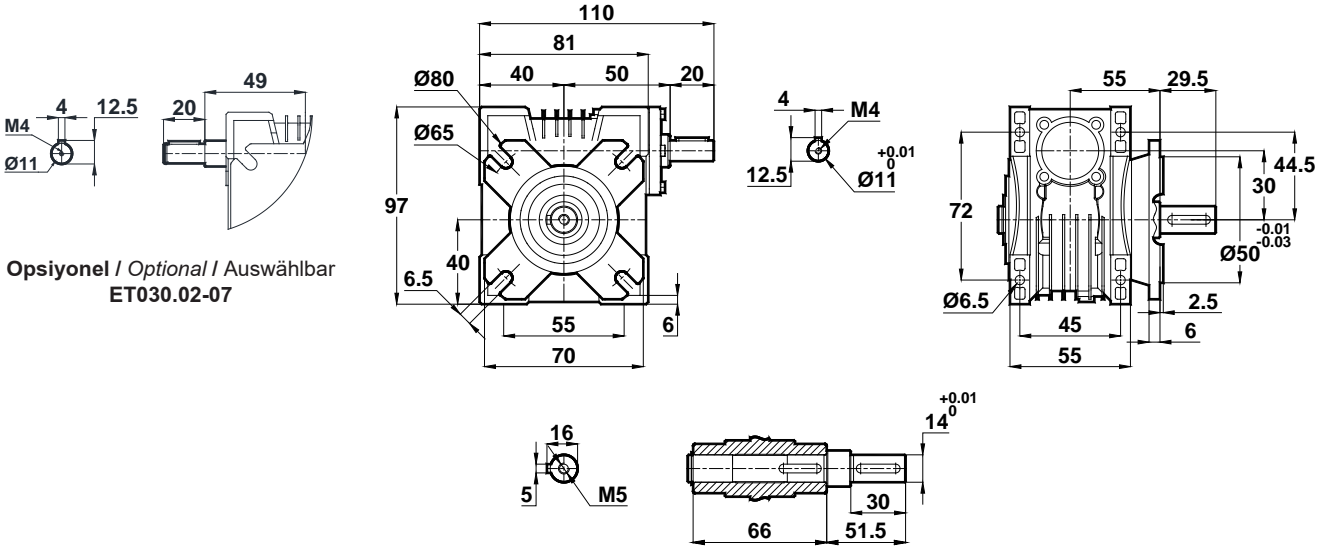

#### ET030.03

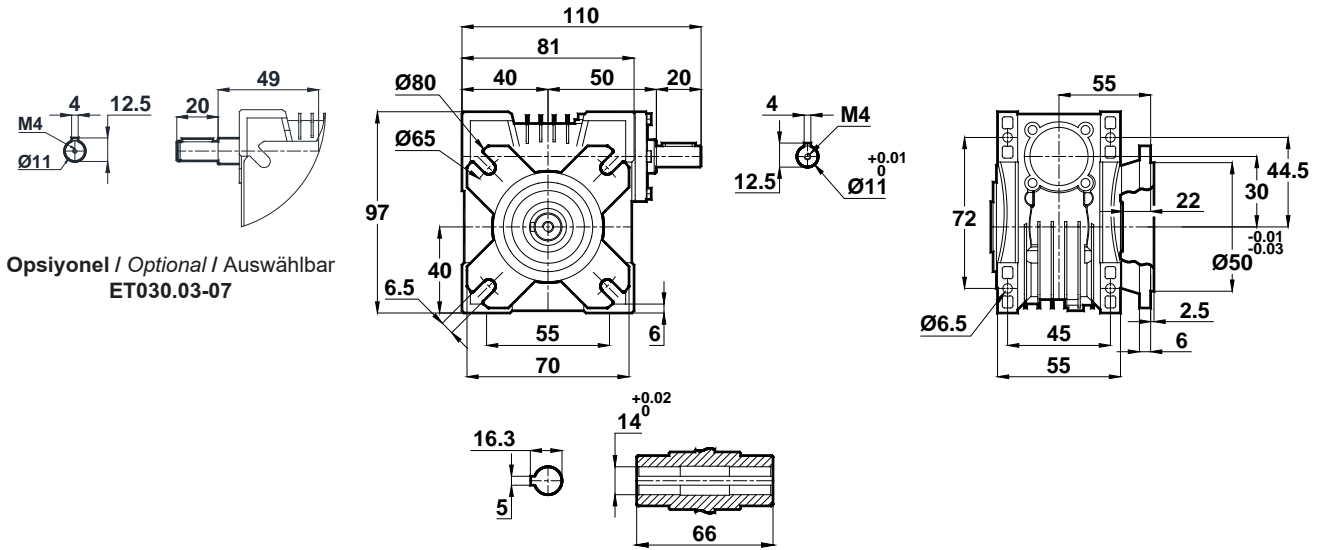

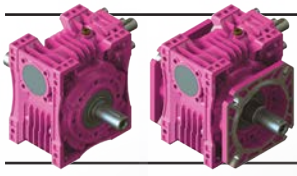

# Ölçü Sayfaları

## Dimension Pages

### Abmessungsseiten

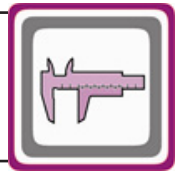

-Mil ucu çekirme deliği DIN 332 sayfa 2 / Tapped center hole to DIN 332, sheet 2 / Zentrierung mit Gewinde DIN 332, Blatt 2

#### ET030.04

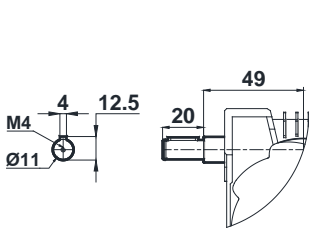

Opsiyonel / Optional / Auswählbar  
ET030.04-07

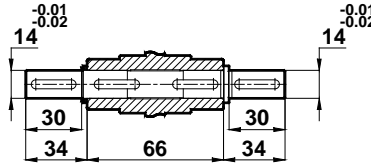
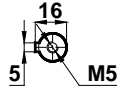
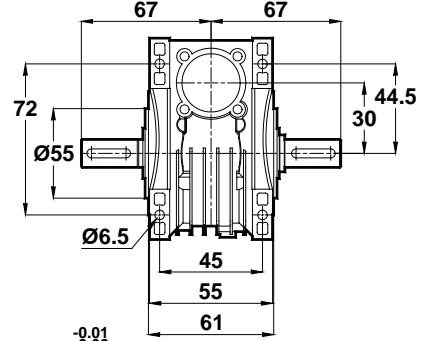
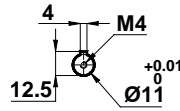
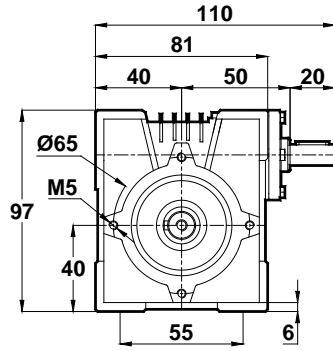

#### ET030.05

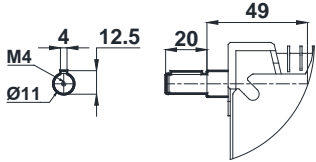

Opsiyonel / Optional / Auswählbar  
ET030.05-07

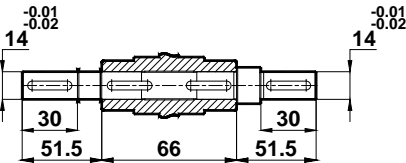
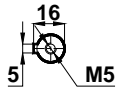
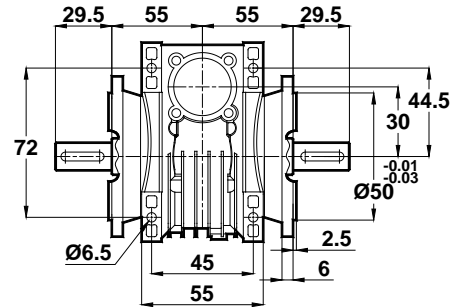
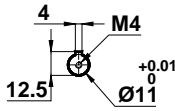
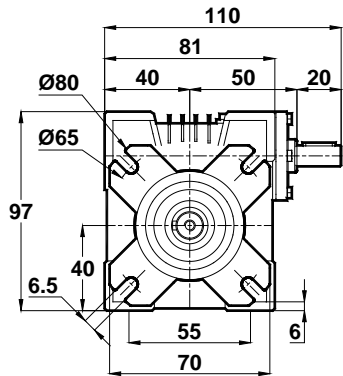



# Ölçü Sayfaları Dimension Pages Abmessungsseiten



-Mil ucu çekirme deliği DIN 332 sayfa 2 / Tapped center hole to DIN 332, sheet 2 / Zentrierung mit Gewinde DIN 332, Blatt 2

ET030.08

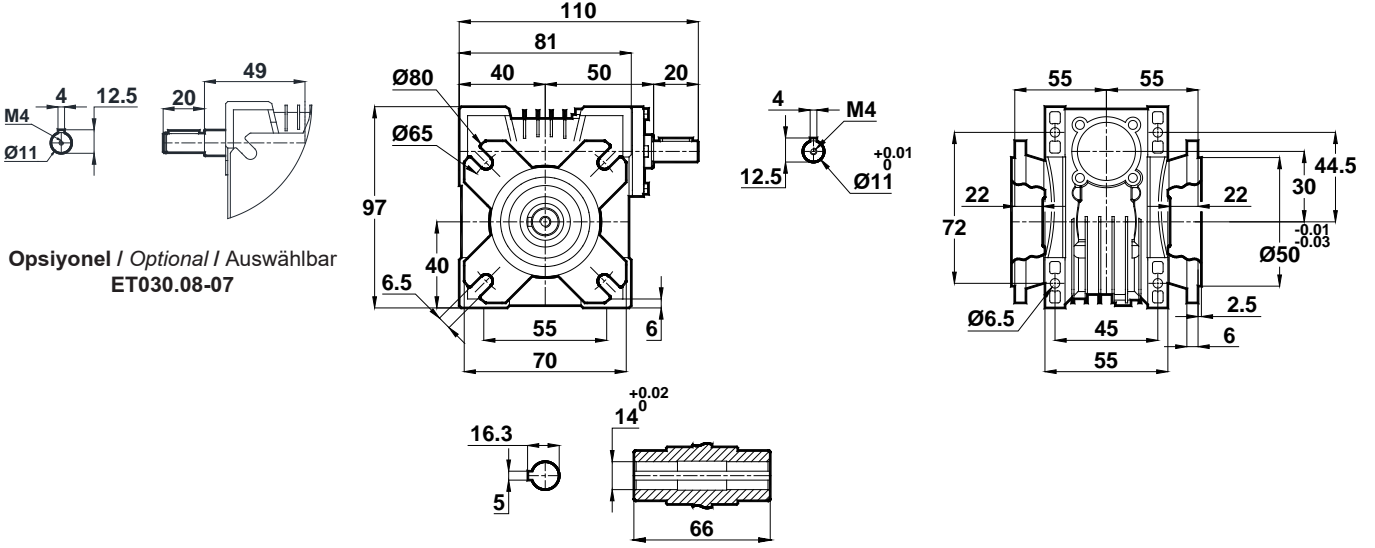

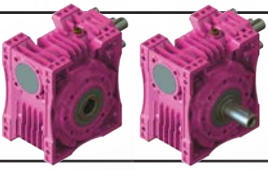

# Ölçü Sayfaları Dimension Pages Abmessungsseiten

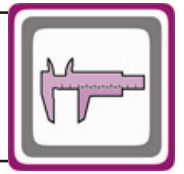

-Mil ucu çekirme deliği DIN 332 sayfa 2 / Tapped center hole to DIN 332, sheet 2 / Zentrierung mit Gewinde DIN 332, Blatt 2

## ET040.00

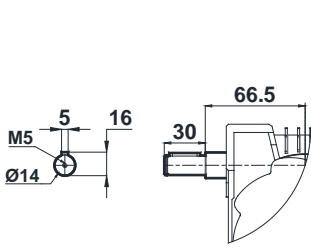

Opsiyonel / Optional / Auswählbar  
ET040.00-07

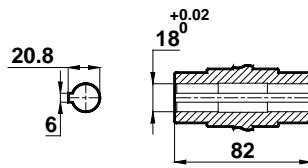
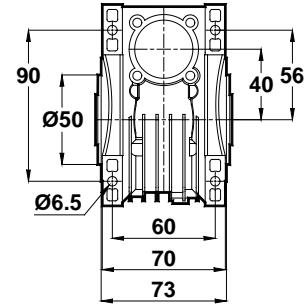
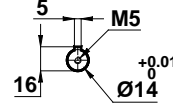
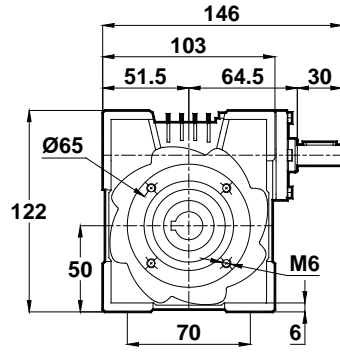

## ET040.01

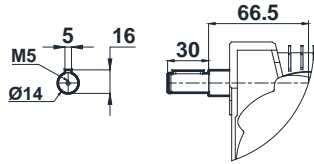

Opsiyonel / Optional / Auswählbar  
ET040.01-07

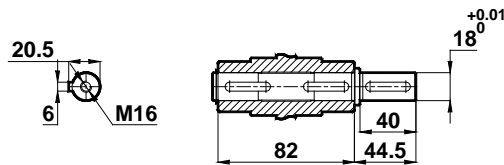
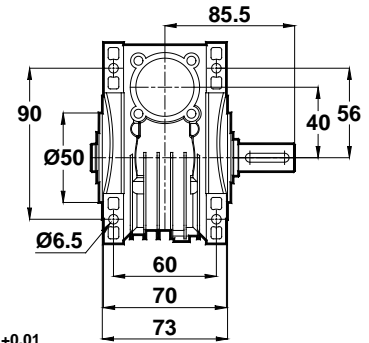
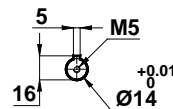
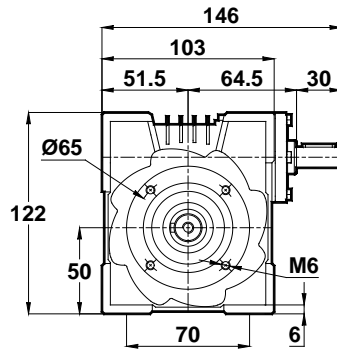

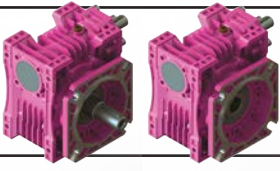

# Ölçü Sayfaları

## Dimension Pages

### Abmessungsseiten



-Mil ucu çekirme deliği DIN 332 sayfa 2 / Tapped center hole to DIN 332, sheet 2 / Zentrierung mit Gewinde DIN 332, Blatt 2

#### ET040.02

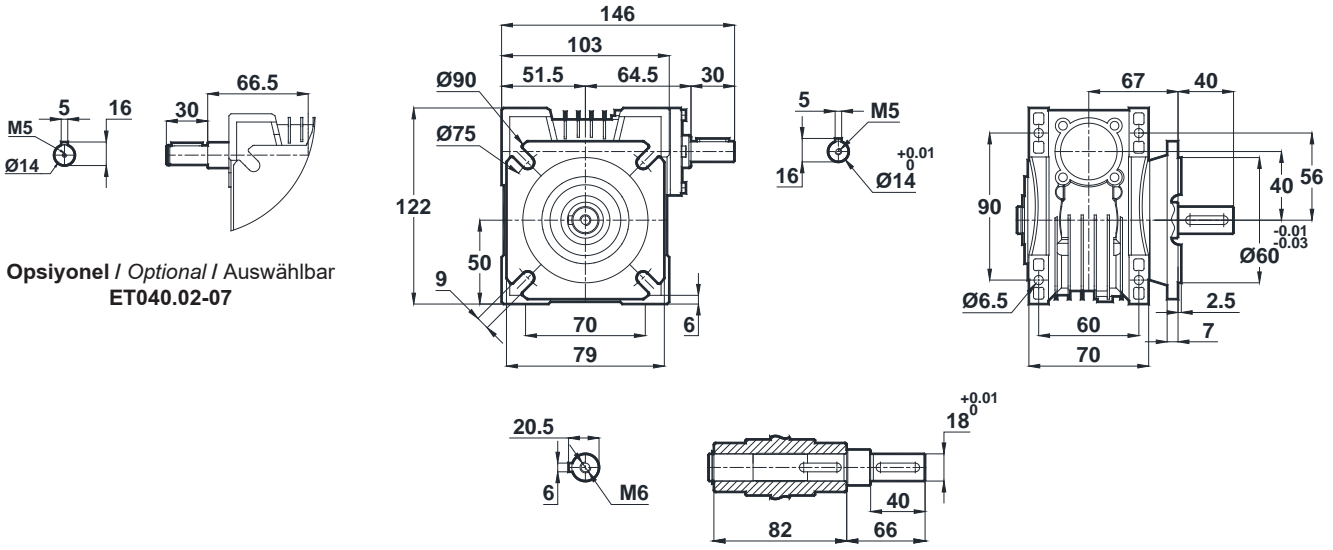

Opsiyonel / Optional / Auswählbar  
ET040.02-07

#### ET040.03

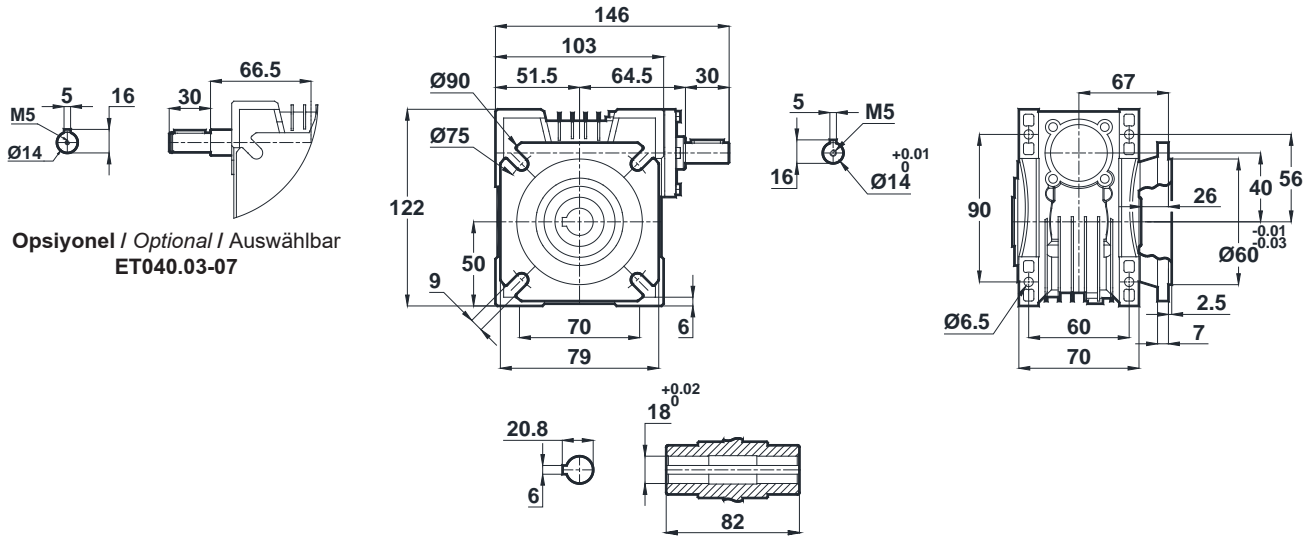

Opsiyonel / Optional / Auswählbar  
ET040.03-07

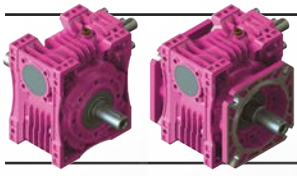

# Ölçü Sayfaları

## Dimension Pages

### Abmessungsseiten



-Mil ucu çekirme deliği DIN 332 sayfa 2 / Tapped center hole to DIN 332, sheet 2 / Zentrierung mit Gewinde DIN 332, Blatt 2

#### ET040.04

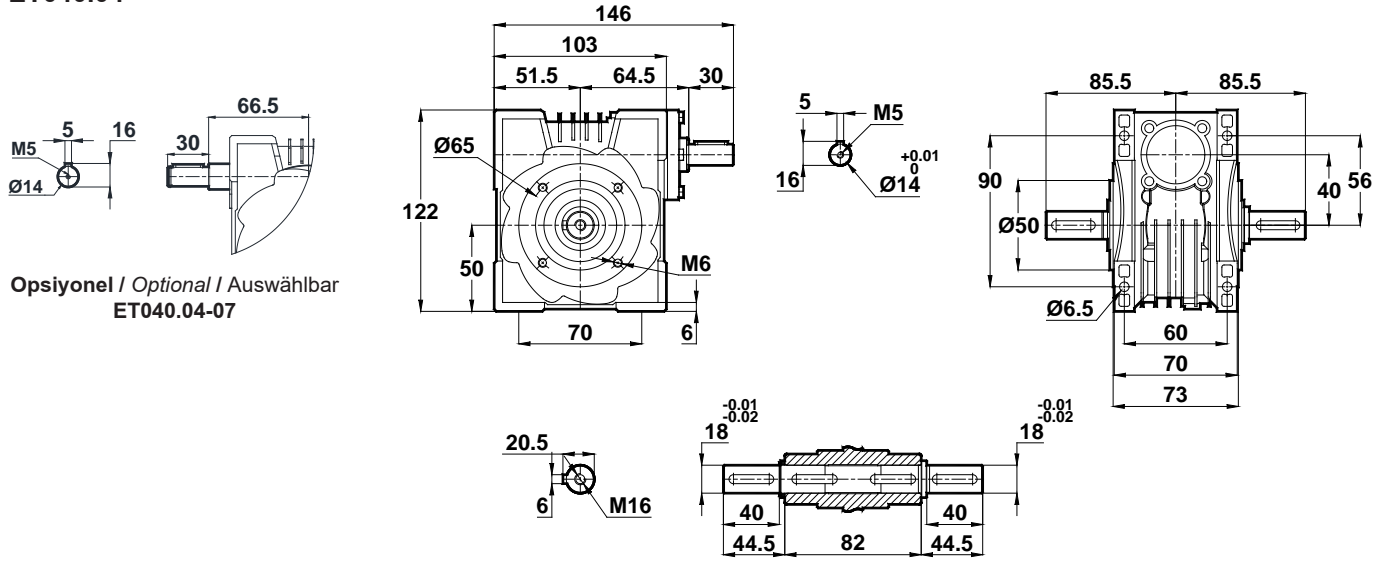

Opsiyonel / Optional / Auswählbar  
ET040.04-07

#### ET040.05

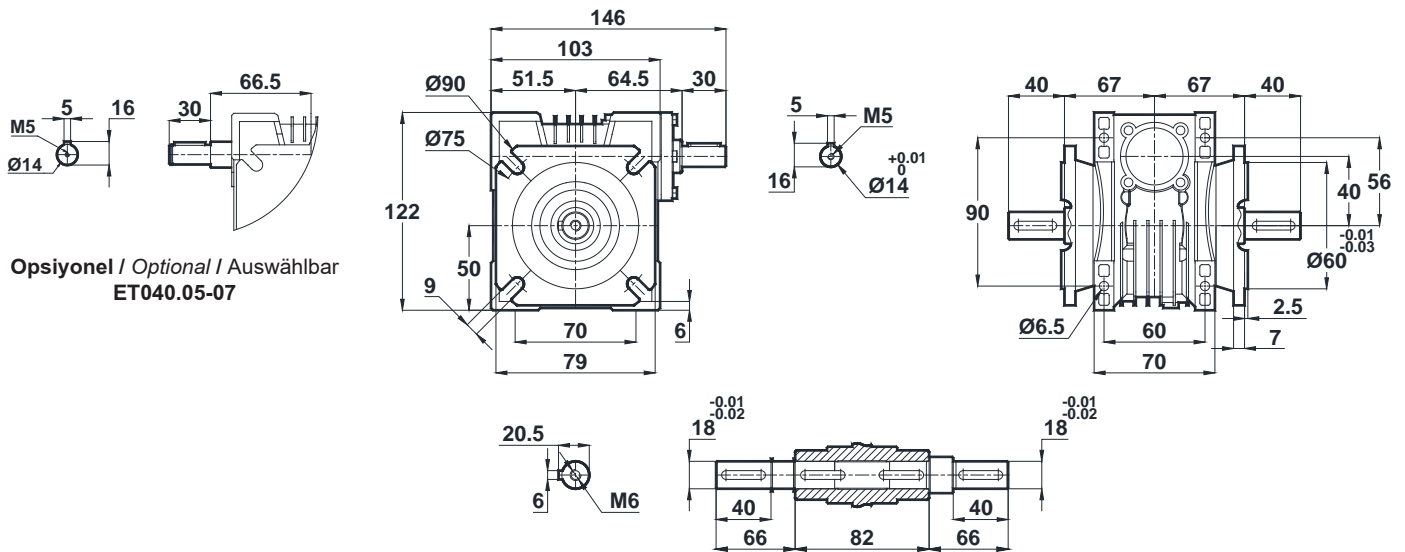

Opsiyonel / Optional / Auswählbar  
ET040.05-07





# Ölçü Sayfaları

## Dimension Pages

### Abmessungsseiten



-Mil ucu çekirme deliği DIN 332 sayfa 2 / Tapped center hole to DIN 332, sheet 2 / Zentrierung mit Gewinde DIN 332, Blatt 2

ET040.08

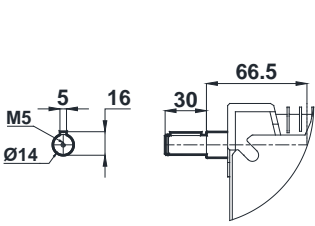

Opsiyonel / Optional / Auswählbar  
ET040.08-07

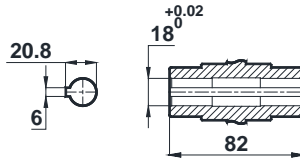
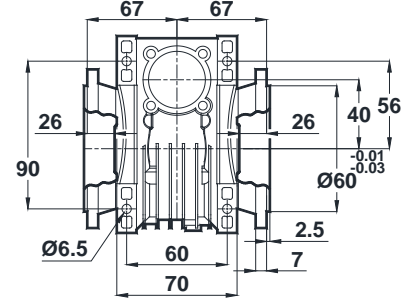
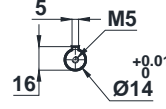
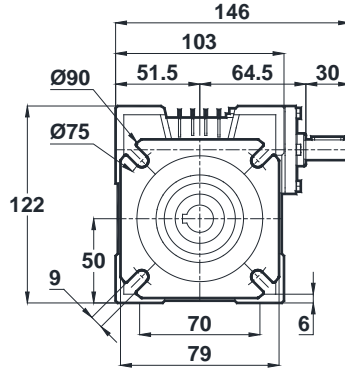

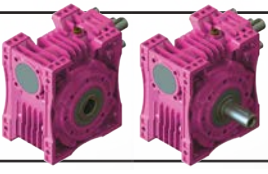

# Ölçü Sayfaları

## Dimension Pages

### Abmessungsseiten

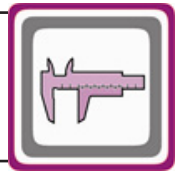

-Mil ucu çekirme deliği DIN 332 sayfa 2 / Tapped center hole to DIN 332, sheet 2 / Zentrierung mit Gewinde DIN 332, Blatt 2

#### ET050.00

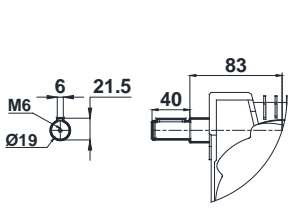

Opsiyonel / Optional / Auswählbar  
ET050.00-07

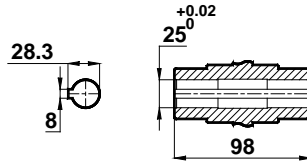
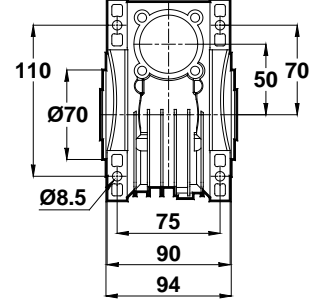
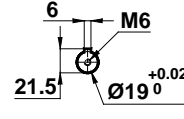
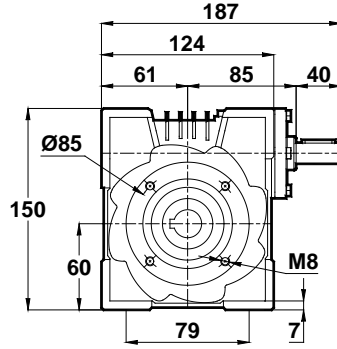

#### ET050.01

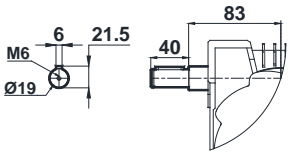

Opsiyonel / Optional / Auswählbar  
ET050.01-07

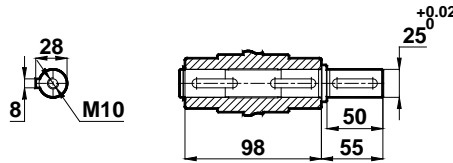
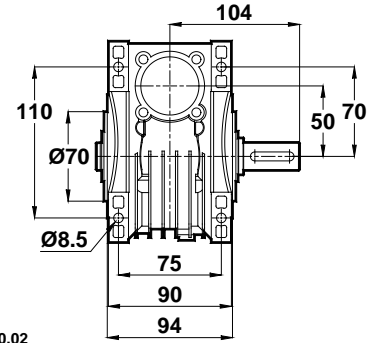
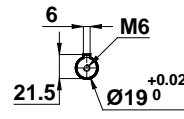
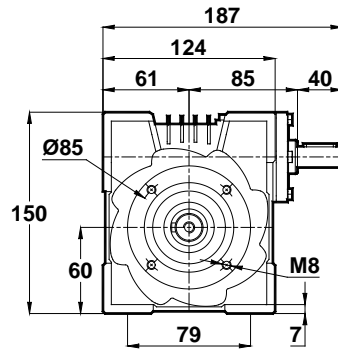

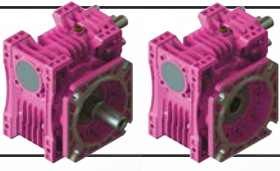

# Ölçü Sayfaları

## Dimension Pages

### Abmessungsseiten



-Mil ucu çekirme deliği DIN 332 sayfa 2 / Tapped center hole to DIN 332, sheet 2 / Zentrierung mit Gewinde DIN 332, Blatt 2

#### ET050.02

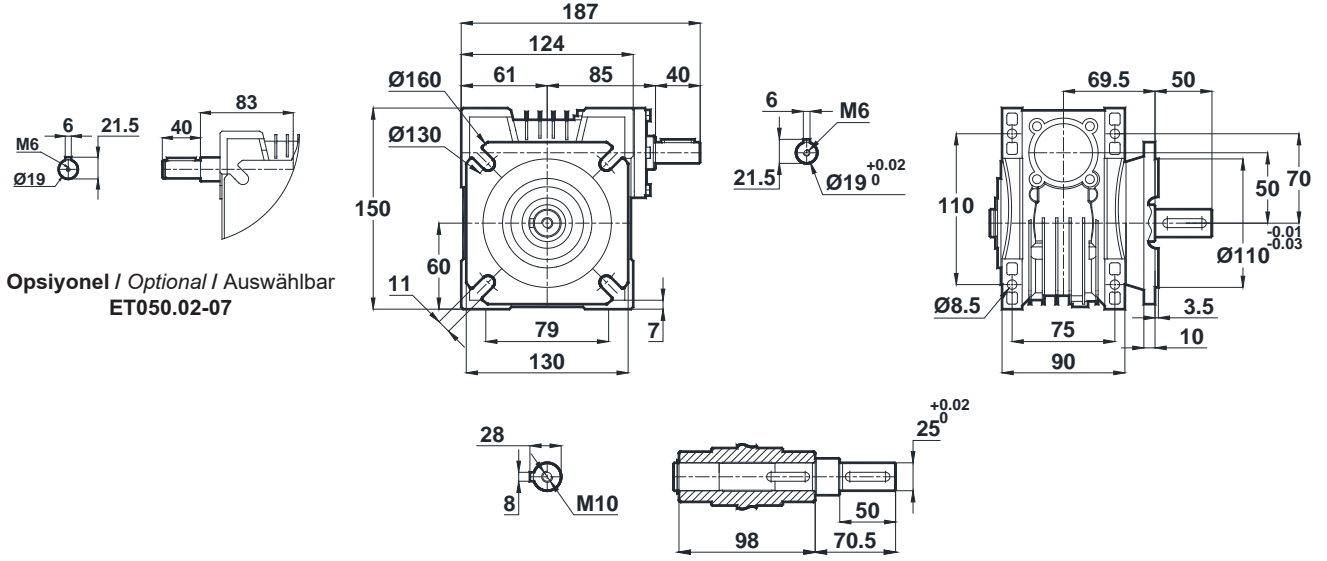

Opsiyonel / Optional / Auswählbar  
ET050.02-07

#### ET050.03

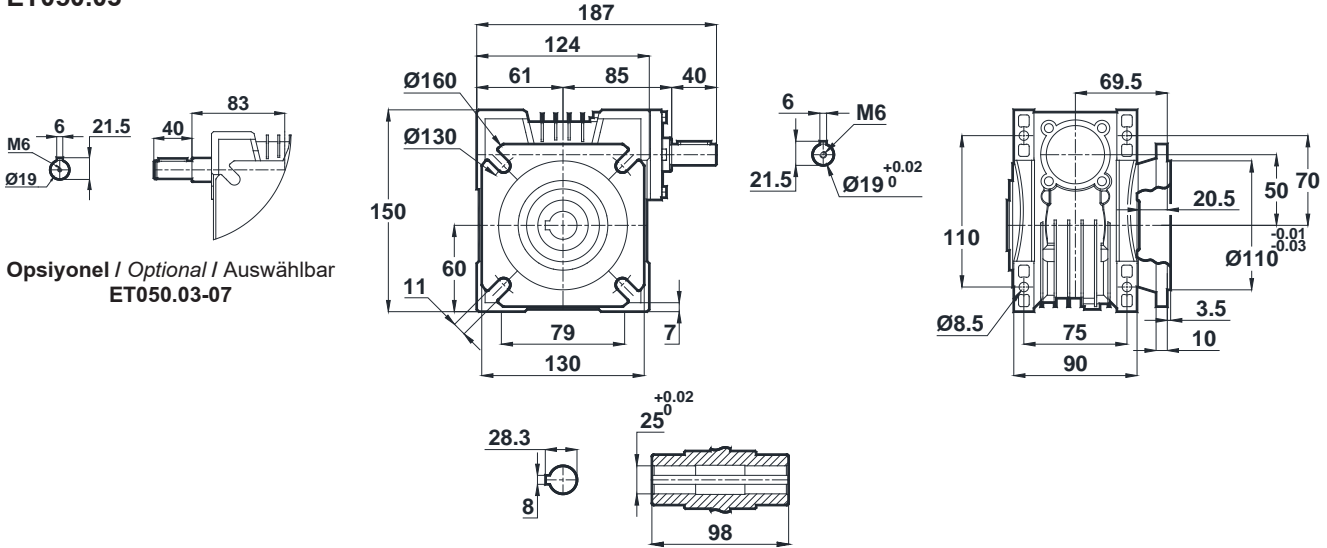

Opsiyonel / Optional / Auswählbar  
ET050.03-07

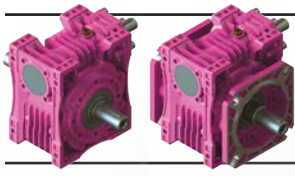

# Ölçü Sayfaları

## Dimension Pages

### Abmessungsseiten

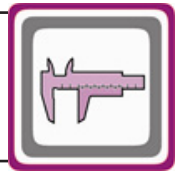

-Mil ucu çekirme deliği DIN 332 sayfa 2 / Tapped center hole to DIN 332, sheet 2 / Zentrierung mit Gewinde DIN 332, Blatt 2

#### ET050.04

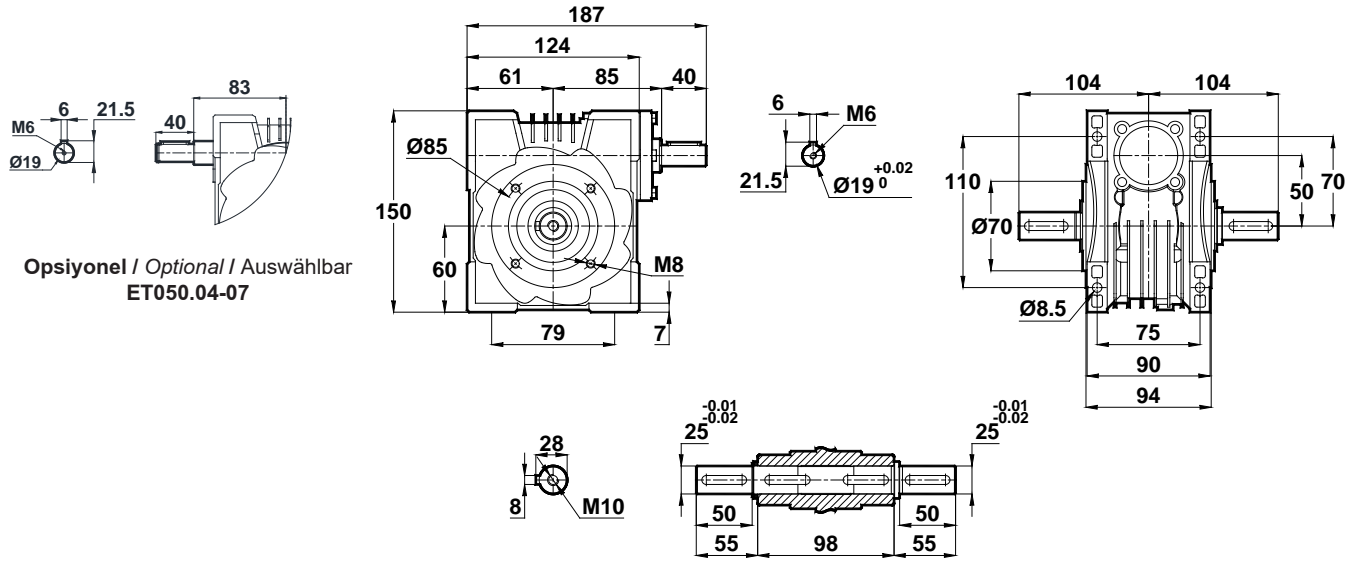

#### ET050.05

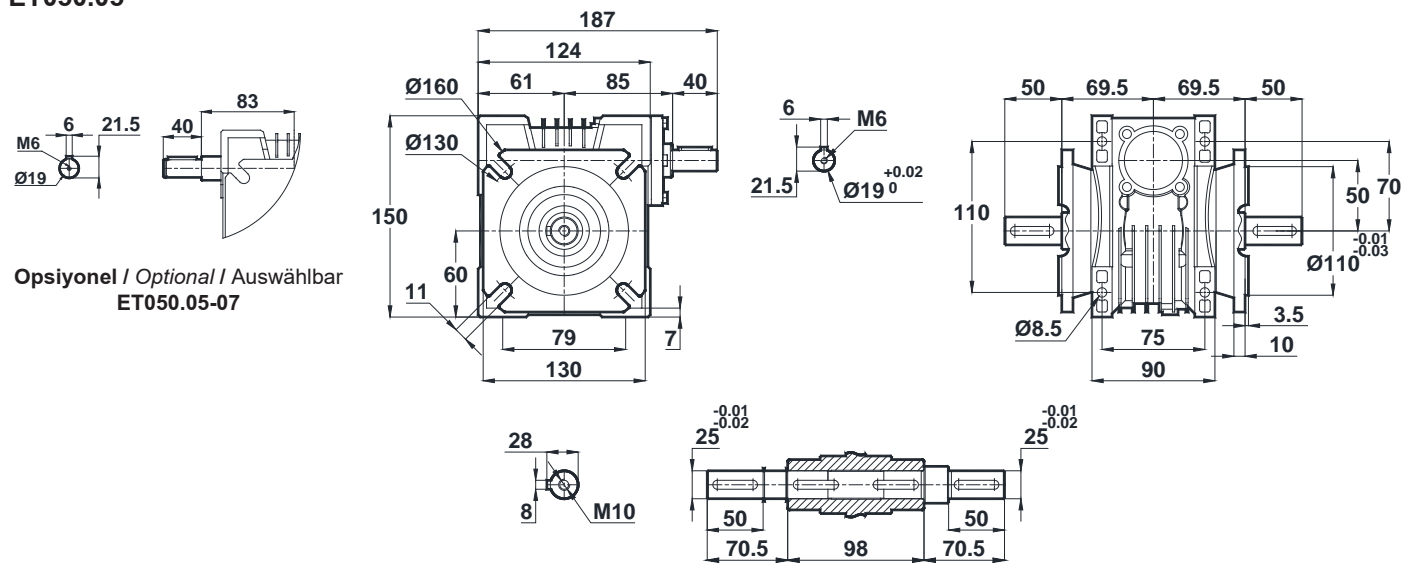



# Ölçü Sayfaları Dimension Pages Abmessungsseiten



-Mil ucu çekirme deliği DIN 332 sayfa 2 / Tapped center hole to DIN 332, sheet 2 / Zentrierung mit Gewinde DIN 332, Blatt 2

ET050.08

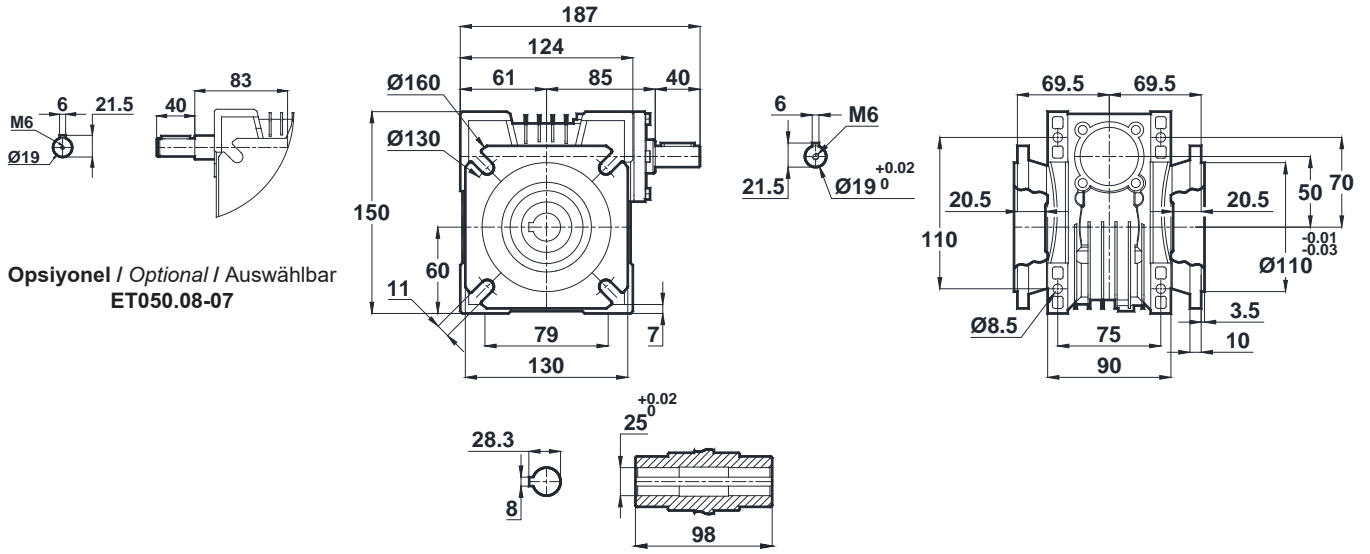

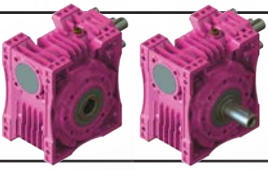

# Ölçü Sayfaları

## Dimension Pages

### Abmessungsseiten

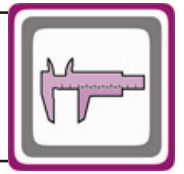

-Mil ucu çekirme deliği DIN 332 sayfa 2 / Tapped center hole to DIN 332, sheet 2 / Zentrierung mit Gewinde DIN 332, Blatt 2

#### ET063.00

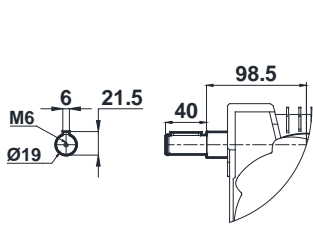

Opsiyonel / Optional / Auswählbar  
ET063.00-07

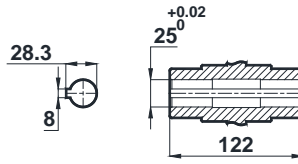
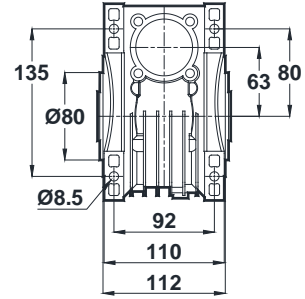
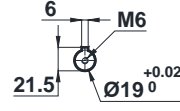
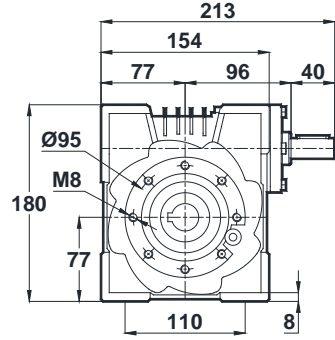

#### ET063.01

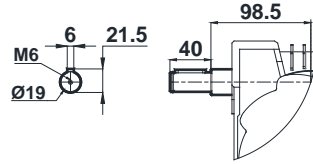

Opsiyonel / Optional / Auswählbar  
ET063.01-07

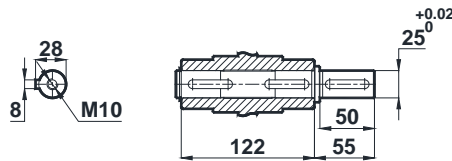
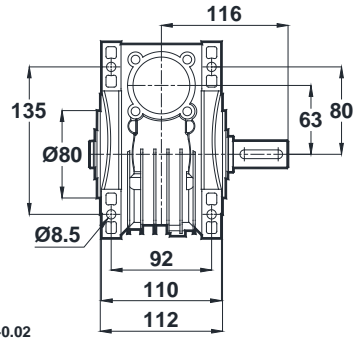
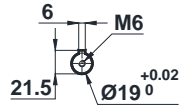
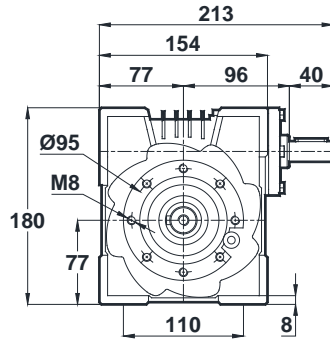

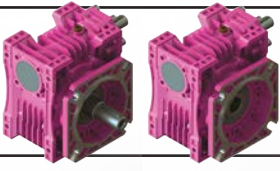

# Ölçü Sayfaları

## Dimension Pages

### Abmessungsseiten



-Mil ucu çekirme deliği DIN 332 sayfa 2 / Tapped center hole to DIN 332, sheet 2 / Zentrierung mit Gewinde DIN 332, Blatt 2

#### ET063.02

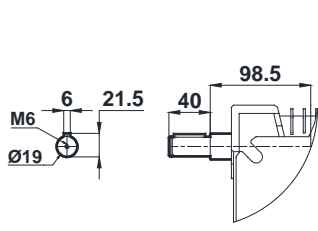

Opsiyonel / Optional / Auswählbar  
ET063.02-07

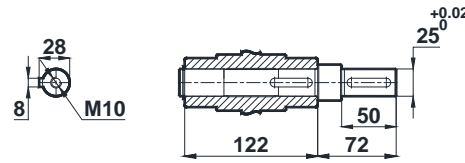
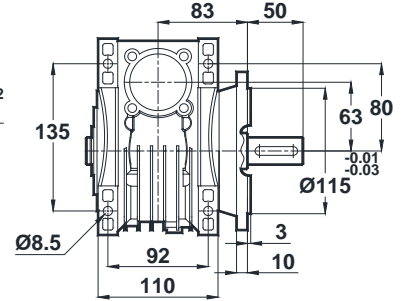
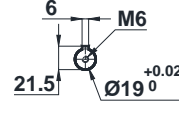
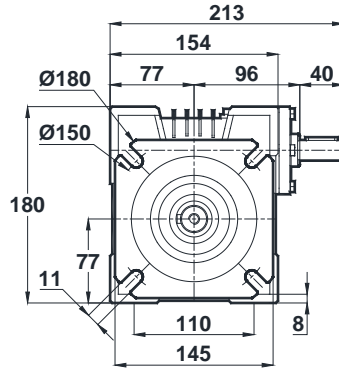

#### ET063.03

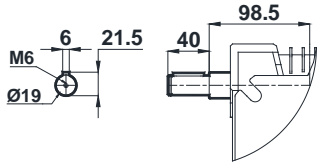

Opsiyonel / Optional / Auswählbar  
ET063.03-07

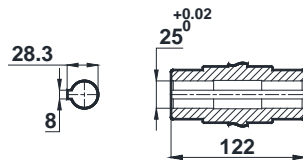
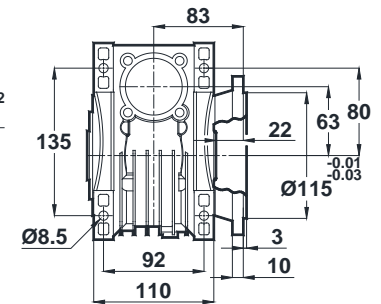
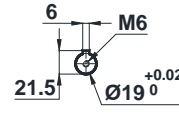
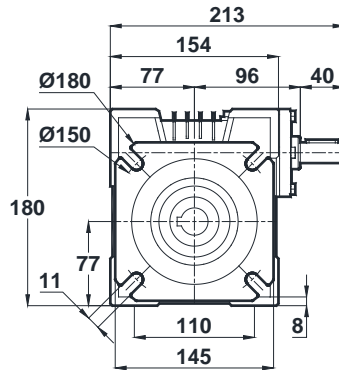

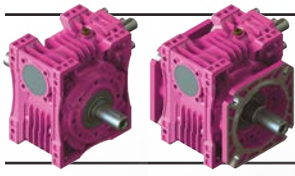

# Ölçü Sayfaları

## Dimension Pages

### Abmessungsseiten



-Mil ucu çekirme deliği DIN 332 sayfa 2 / Tapped center hole to DIN 332, sheet 2 / Zentrierung mit Gewinde DIN 332, Blatt 2

#### ET063.04

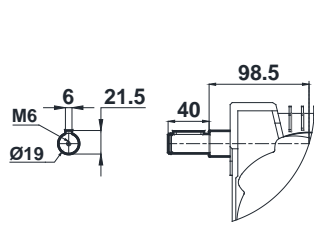

Opsiyonel / Optional / Auswählbar  
ET063.04-07

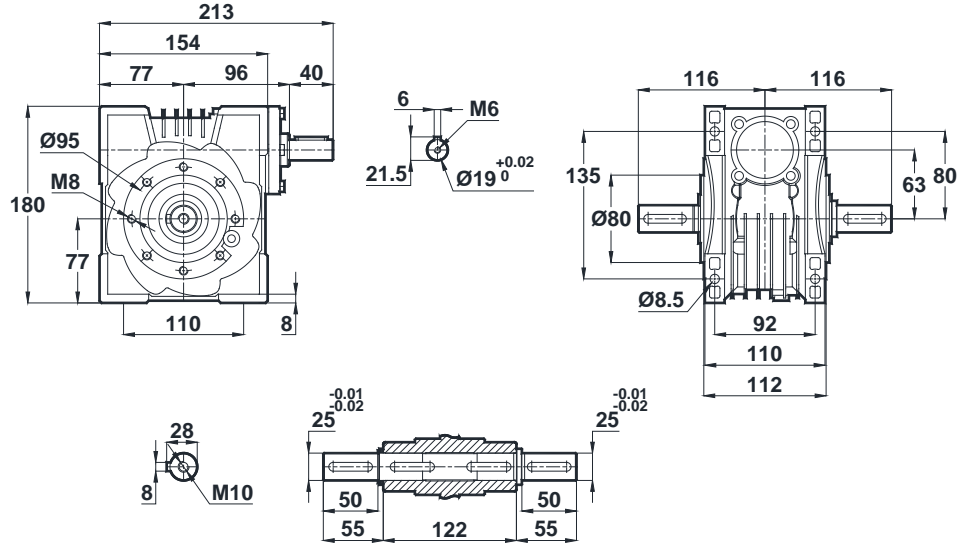

#### ET063.05

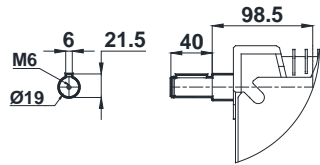

Opsiyonel / Optional / Auswählbar  
ET063.05-07

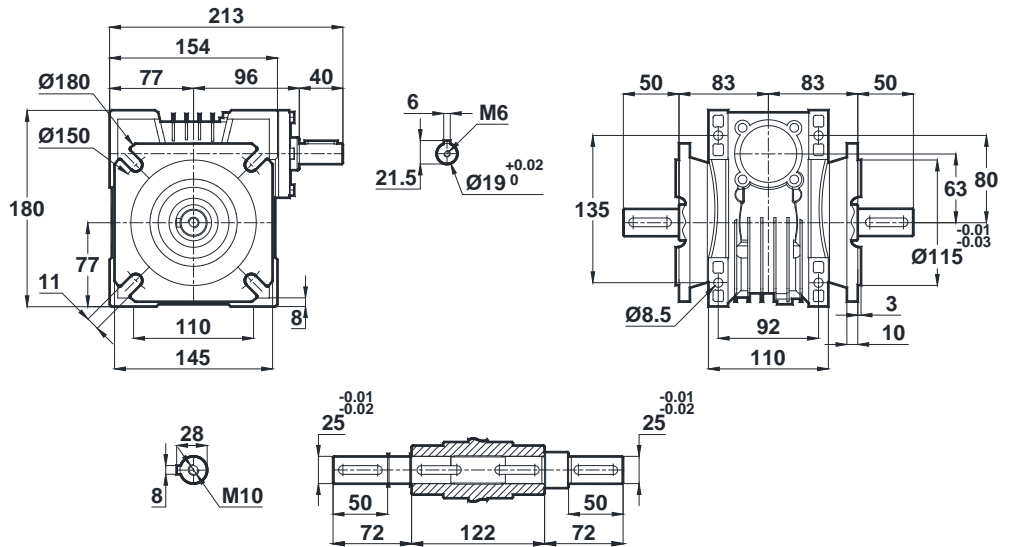





# Ölçü Sayfaları

## Dimension Pages

### Abmessungsseiten



-Mil ucu çekirme deliği DIN 332 sayfa 2 / Tapped center hole to DIN 332, sheet 2 / Zentrierung mit Gewinde DIN 332, Blatt 2

ET063.08

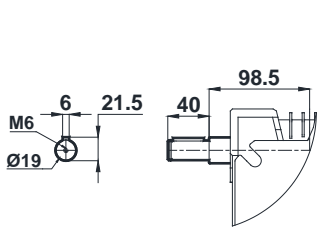

Opsiyonel / Optional / Auswählbar  
ET063.08-07

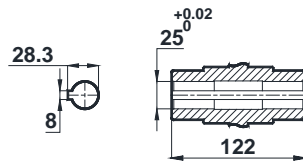
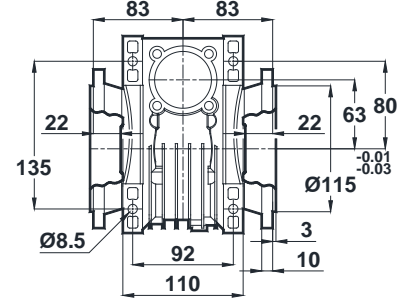
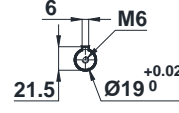
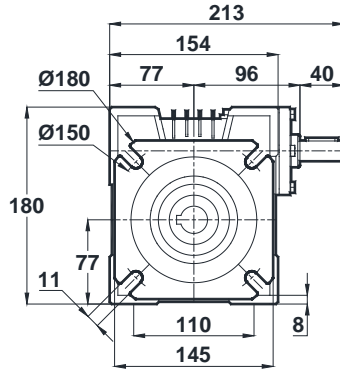

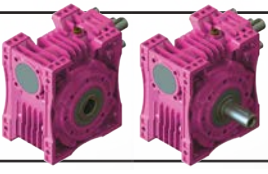

# Ölçü Sayfaları

## Dimension Pages

### Abmessungsseiten

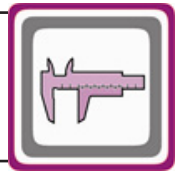

-Mil ucu çekirme deliği DIN 332 sayfa 2 / Tapped center hole to DIN 332, sheet 2 / Zentrierung mit Gewinde DIN 332, Blatt 2

#### ET075.00

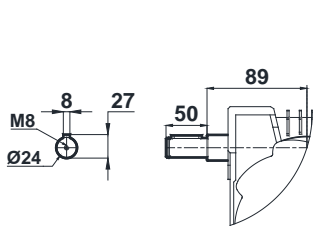

Opsiyonel / Optional / Auswählbar  
ET075.00-07

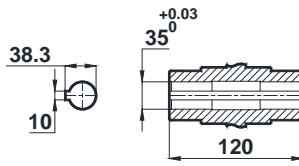
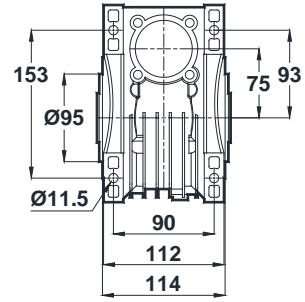
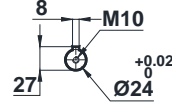
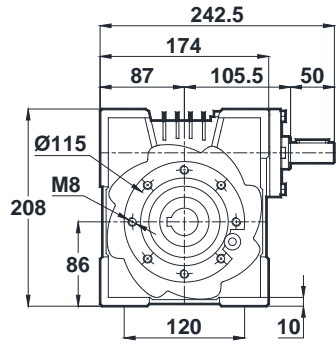

#### ET075.01

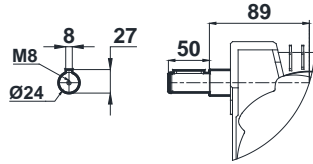

Opsiyonel / Optional / Auswählbar  
ET075.01-07

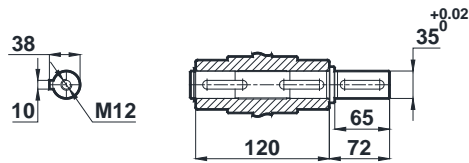
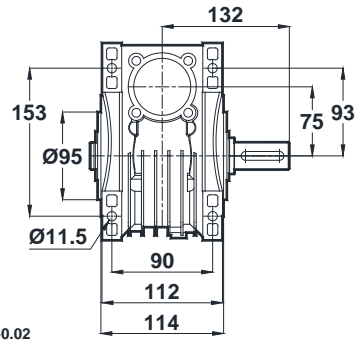
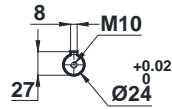
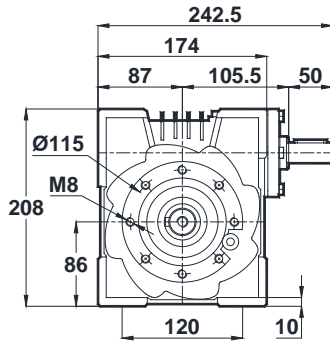

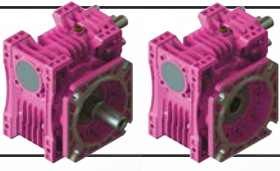

# Ölçü Sayfaları

## Dimension Pages

### Abmessungsseiten



-Mil ucu çekirme deliği DIN 332 sayfa 2 / Tapped center hole to DIN 332, sheet 2 / Zentrierung mit Gewinde DIN 332, Blatt 2

#### ET075.02

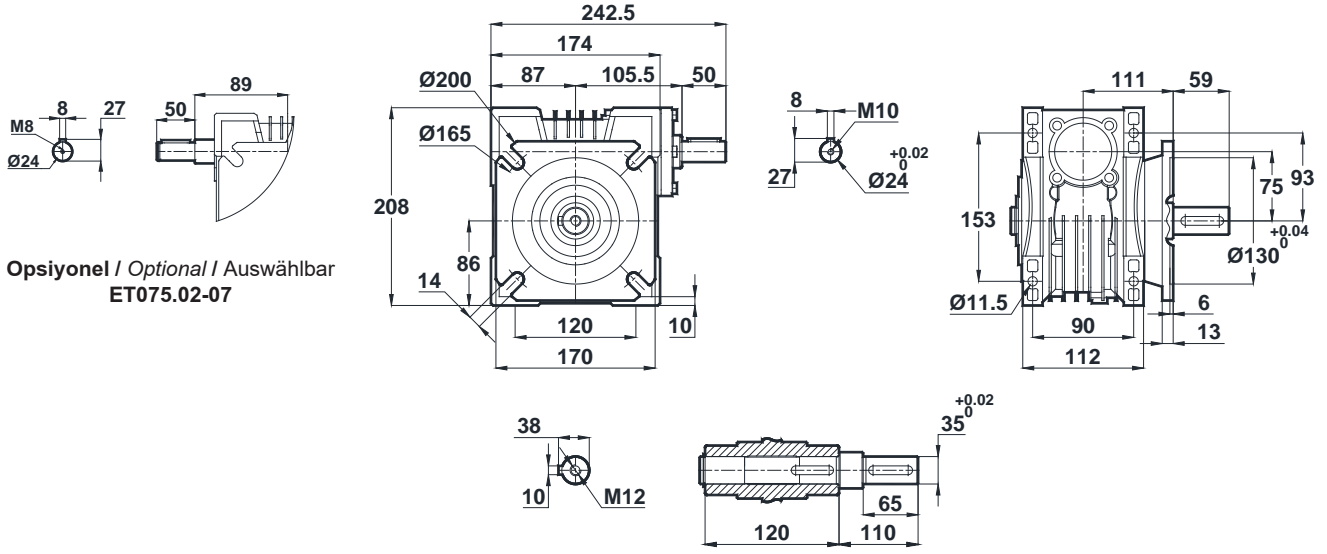

#### ET075.03

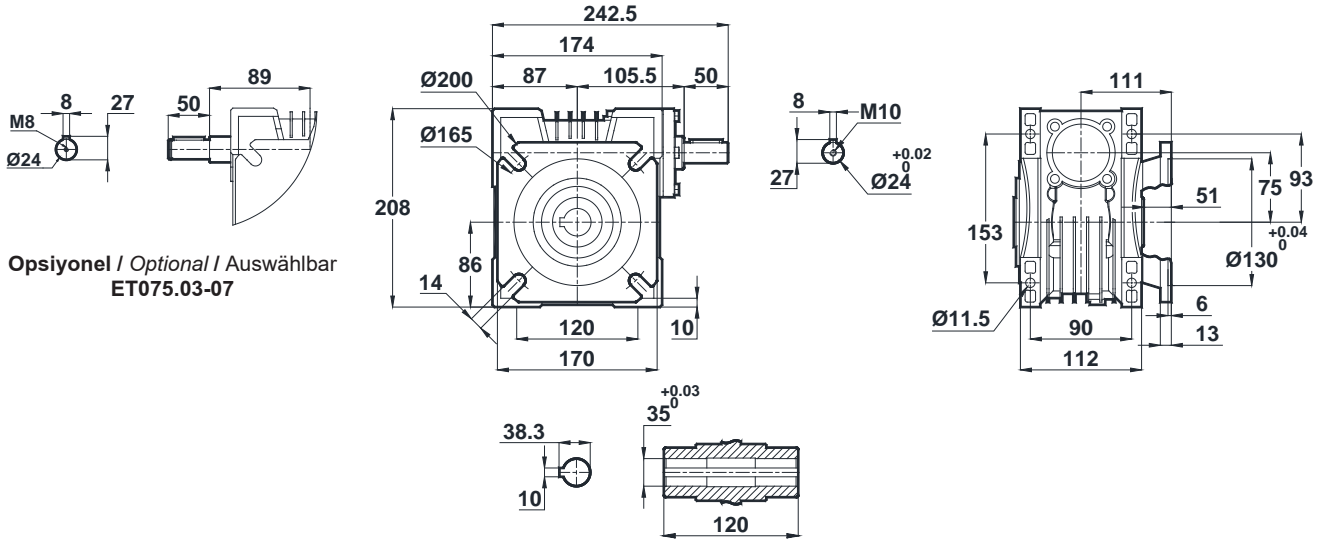

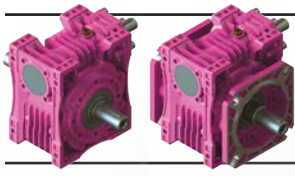

# Ölçü Sayfaları

## Dimension Pages

### Abmessungsseiten

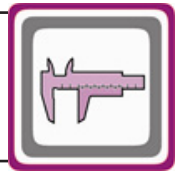

-Mil ucu çekirme deliği DIN 332 sayfa 2 / Tapped center hole to DIN 332, sheet 2 / Zentrierung mit Gewinde DIN 332, Blatt 2

#### ET075.04

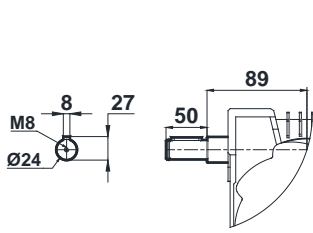

Opsiyonel / Optional / Auswählbar  
ET075.04-07

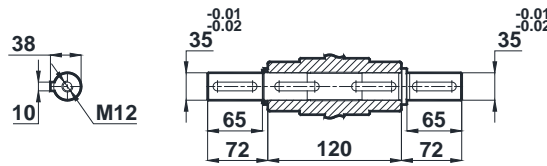
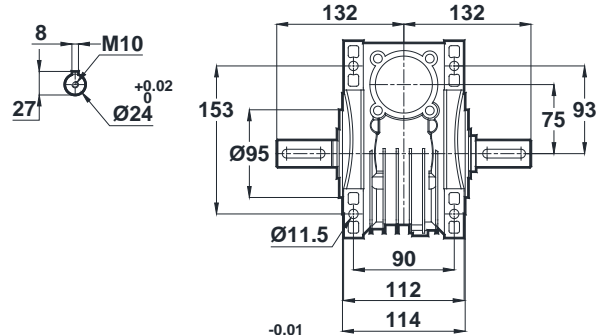
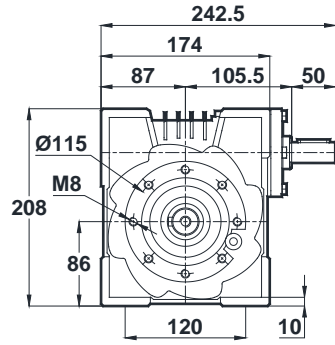

#### ET075.05

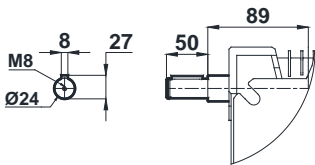

Opsiyonel / Optional / Auswählbar  
ET050.05-07

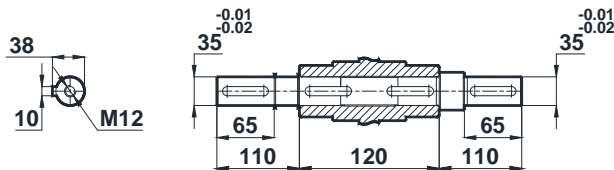
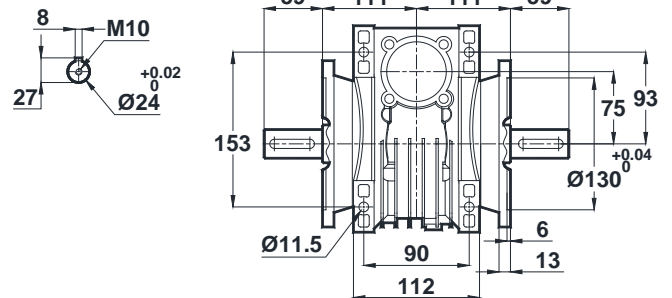
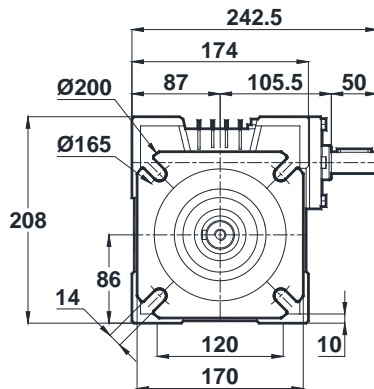



# Ölçü Sayfaları

## Dimension Pages

### Abmessungsseiten



-Mil ucu çekirme deliği DIN 332 sayfa 2 / Tapped center hole to DIN 332, sheet 2 / Zentrierung mit Gewinde DIN 332, Blatt 2

ET075.08

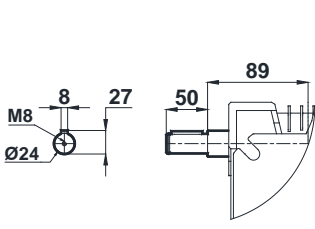

Opsiyonel / Optional / Auswählbar  
ET075.08-07

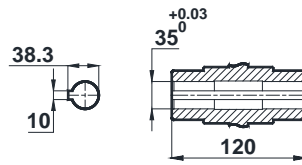
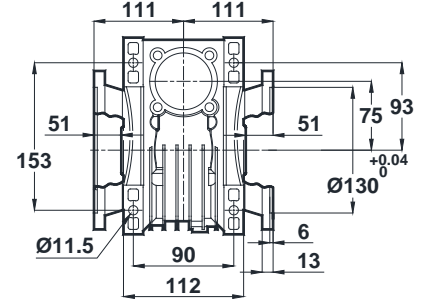
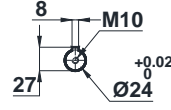
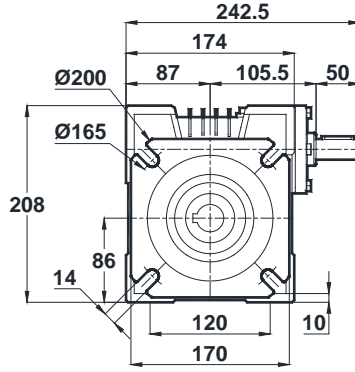

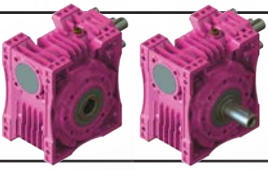

# Ölçü Sayfaları

## Dimension Pages

### Abmessungsseiten

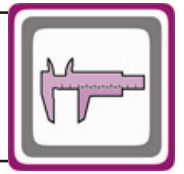

-Mil ucu çekirme deliği DIN 332 sayfa 2 / Tapped center hole to DIN 332, sheet 2 / Zentrierung mit Gewinde DIN 332, Blatt 2

#### ET080.00

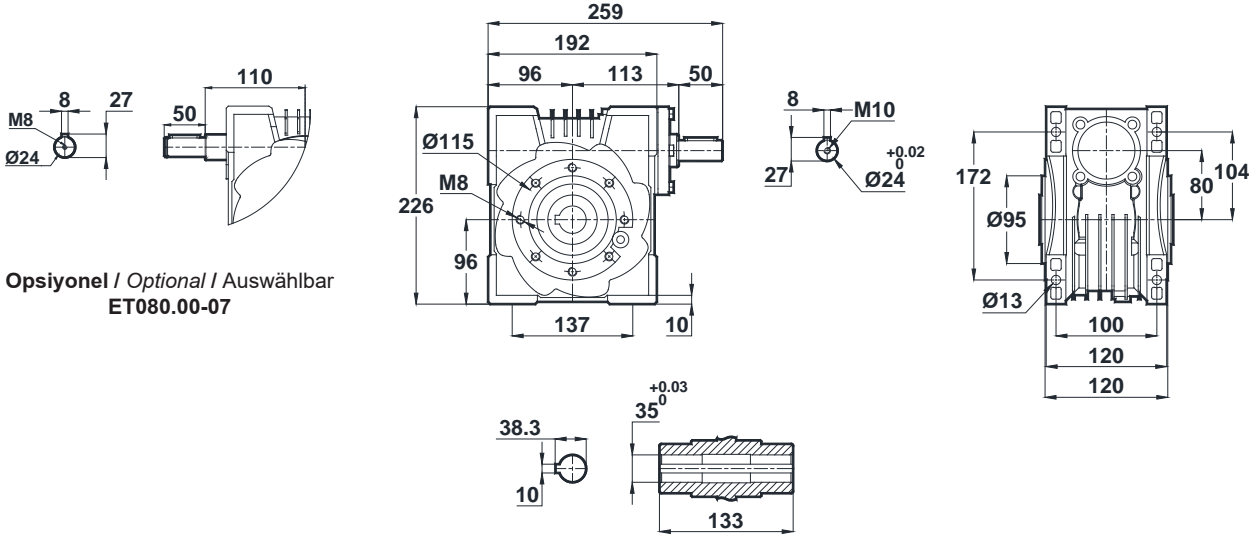

Opsiyonel / Optional / Auswählbar  
ET080.00-07

#### ET080.01

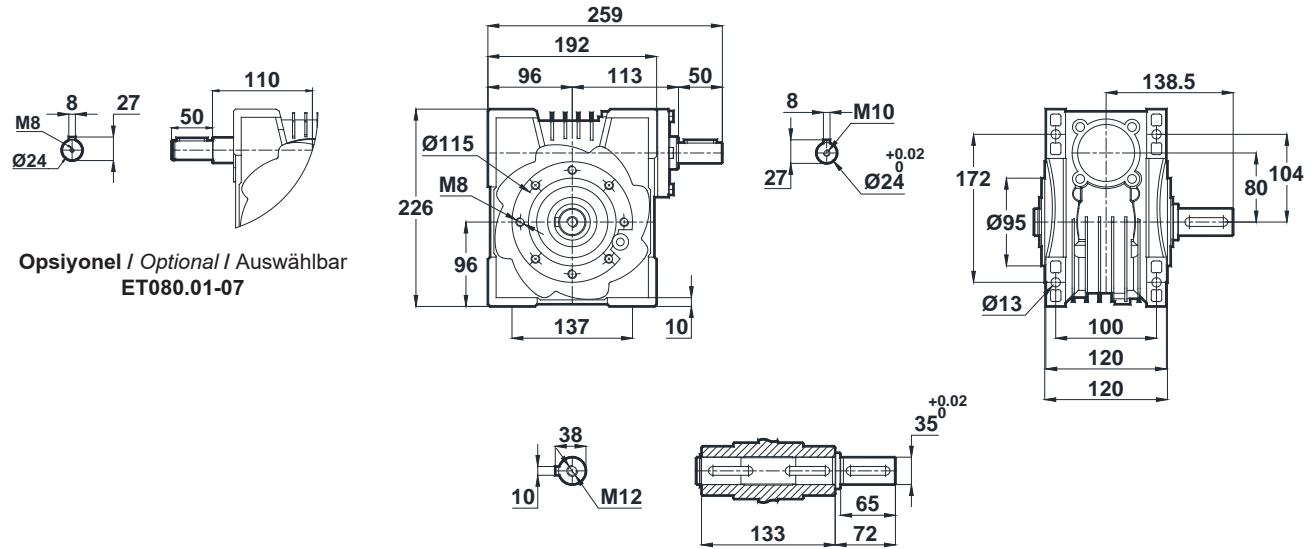

Opsiyonel / Optional / Auswählbar  
ET080.01-07

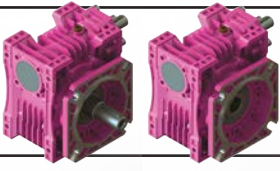

# Ölçü Sayfaları

## Dimension Pages

### Abmessungsseiten



-Mil ucu çekirme deliği DIN 332 sayfa 2 / Tapped center hole to DIN 332, sheet 2 / Zentrierung mit Gewinde DIN 332, Blatt 2

#### ET080.02

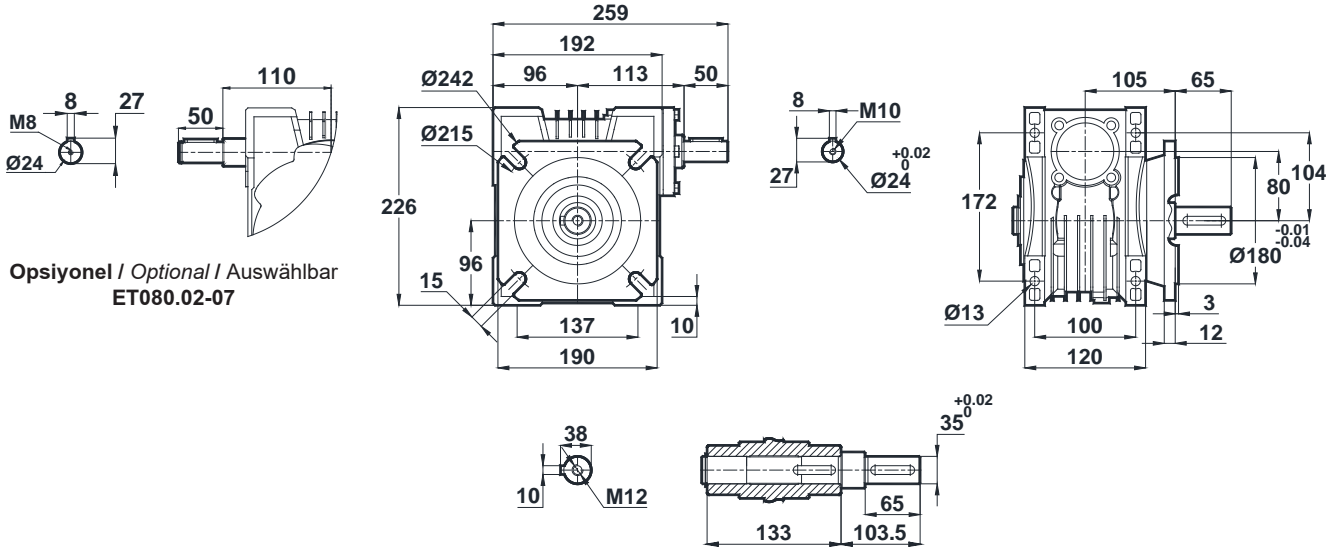

Opsiyonel / Optional / Auswählbar  
ET080.02-07

#### ET080.03

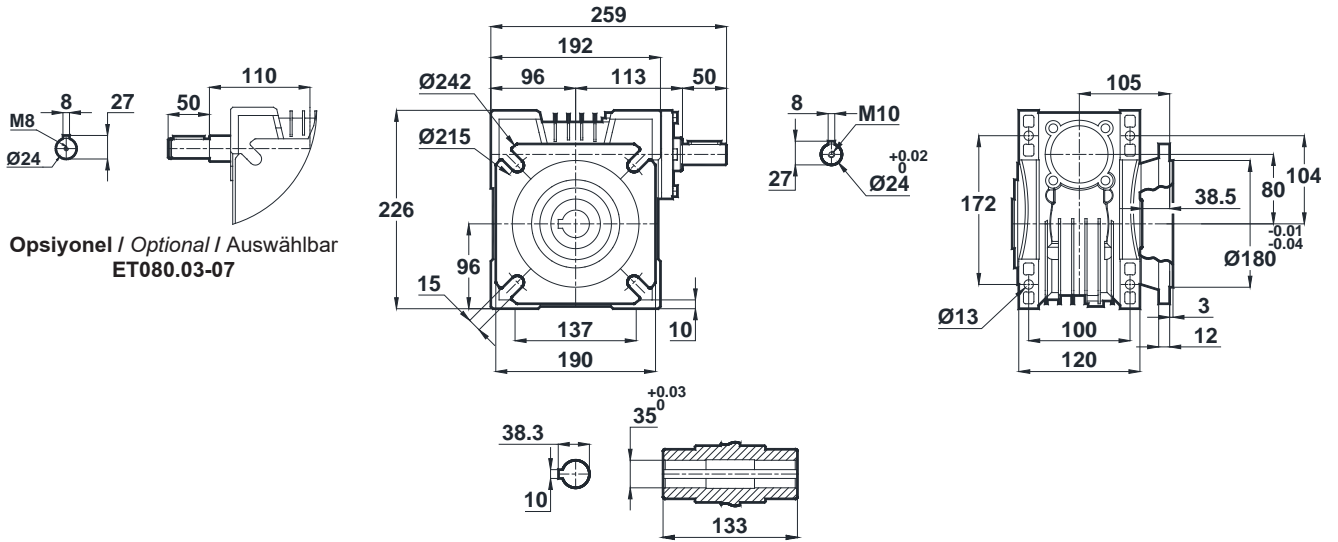

Opsiyonel / Optional / Auswählbar  
ET080.03-07

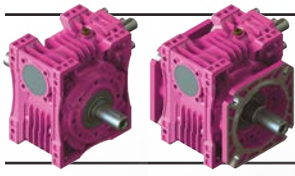

# Ölçü Sayfaları

## Dimension Pages

### Abmessungsseiten



-Mil ucu çekirme deliği DIN 332 sayfa 2 / Tapped center hole to DIN 332, sheet 2 / Zentrierung mit Gewinde DIN 332, Blatt 2

#### ET080.04

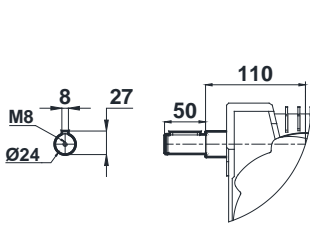

Opsiyonel / Optional / Auswählbar  
ET080.04-07

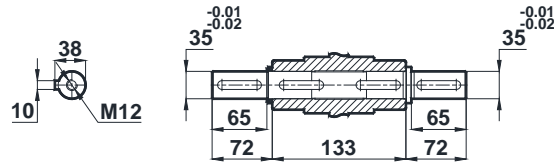
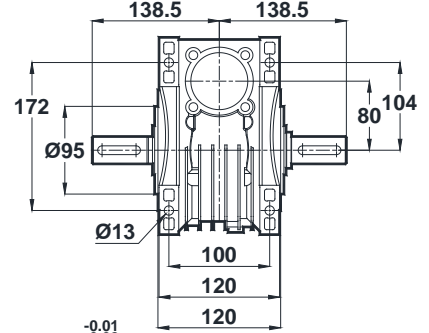
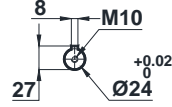
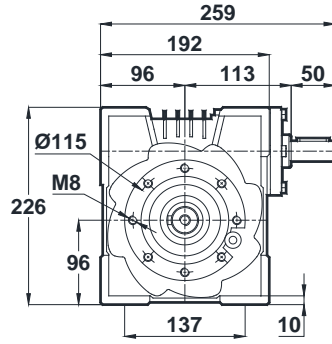

#### ET080.05

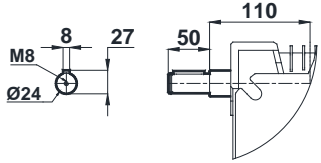

Opsiyonel / Optional / Auswählbar  
ET080.05-07

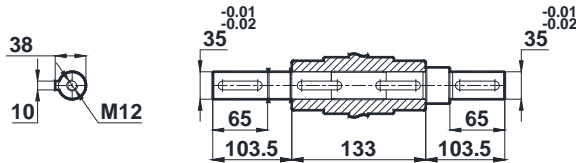
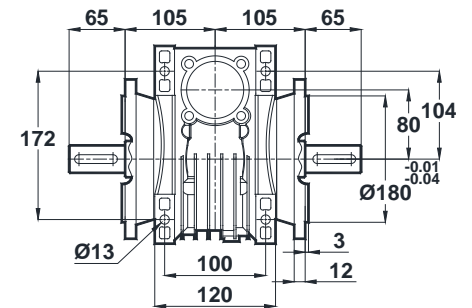
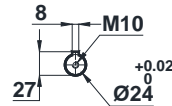
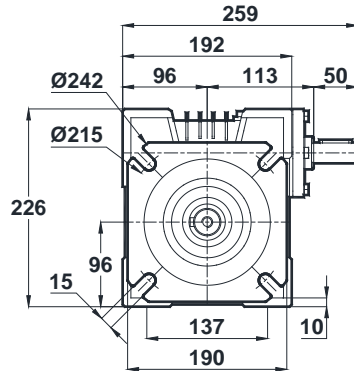





# Ölçü Sayfaları

## Dimension Pages

### Abmessungsseiten



-Mil ucu çekirme deliği DIN 332 sayfa 2 / Tapped center hole to DIN 332, sheet 2 / Zentrierung mit Gewinde DIN 332, Blatt 2

ET080.08

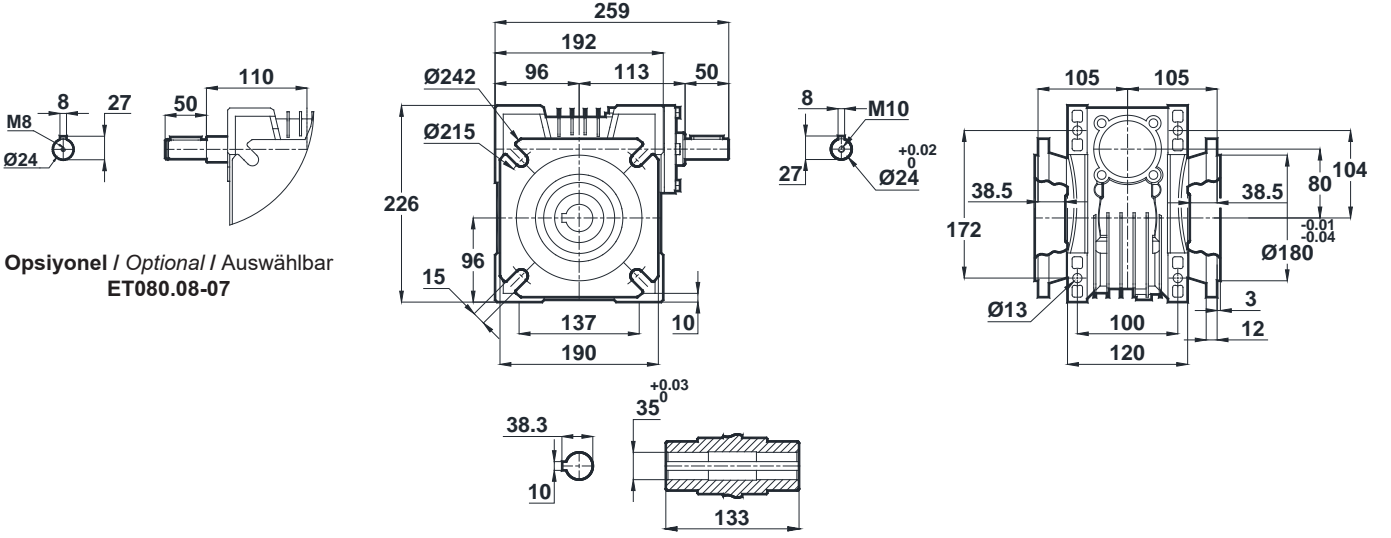

Opsiyonel / Optional / Auswählbar  
ET080.08-07

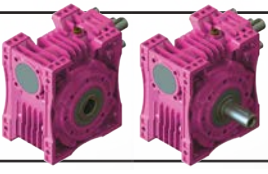

# Ölçü Sayfaları

## Dimension Pages

### Abmessungsseiten



-Mil ucu çekirme deliği DIN 332 sayfa 2 / Tapped center hole to DIN 332, sheet 2 / Zentrierung mit Gewinde DIN 332, Blatt 2

#### ET100.00

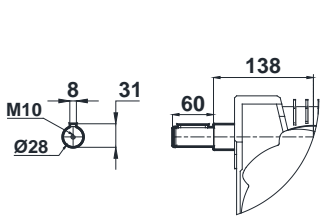

Opsiyonel / Optional / Auswählbar  
ET100.00-07

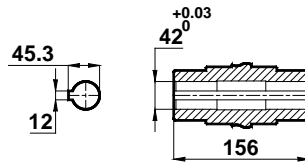
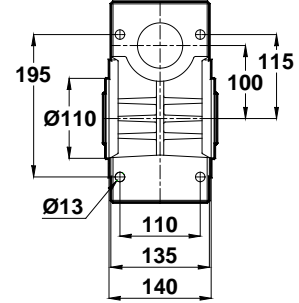
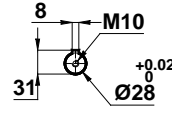
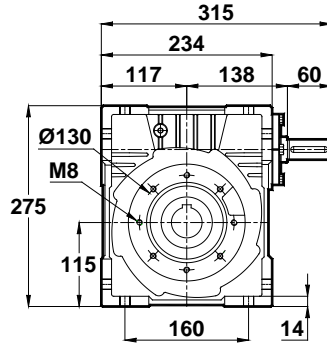

#### ET100.01

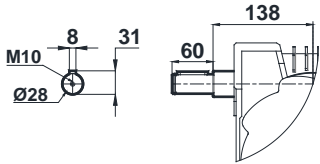

Opsiyonel / Optional / Auswählbar  
ET100.01-07

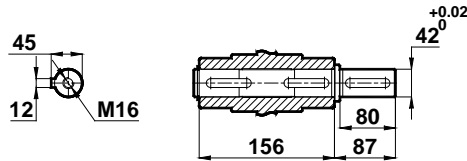
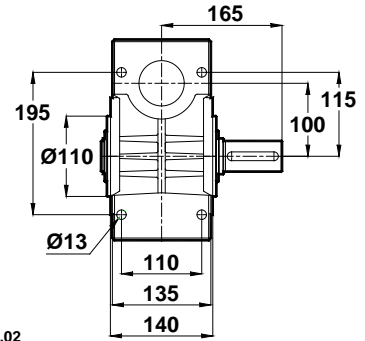
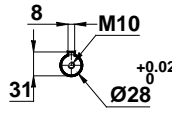
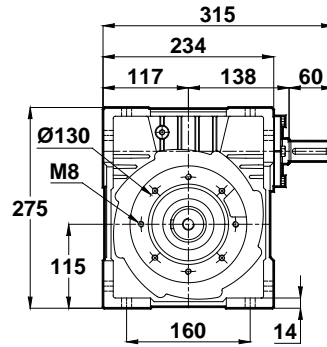

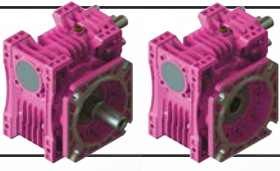

# Ölçü Sayfaları

## Dimension Pages

### Abmessungsseiten



-Mil ucu çekirme deliği DIN 332 sayfa 2 / Tapped center hole to DIN 332, sheet 2 / Zentrierung mit Gewinde DIN 332, Blatt 2

#### ET100.02

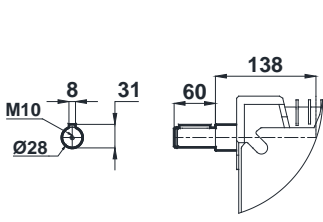

Opsiyonel / Optional / Auswählbar  
ET100.02-07

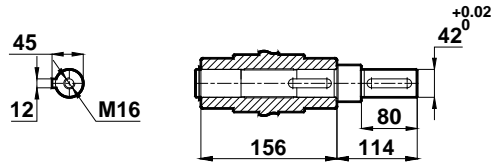
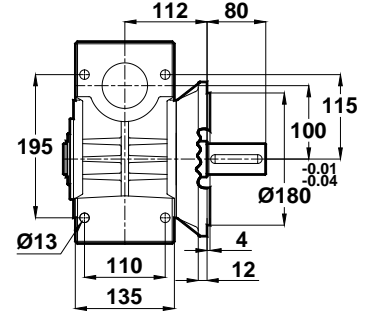
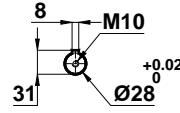
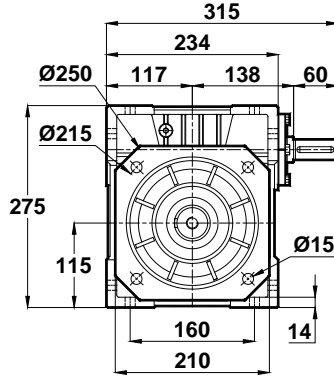

#### ET100.03

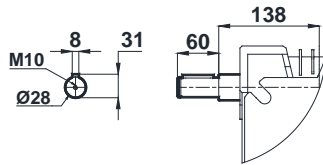

Opsiyonel / Optional / Auswählbar  
ET100.03-07

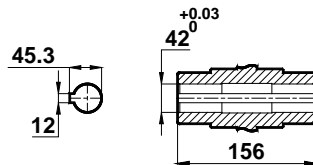
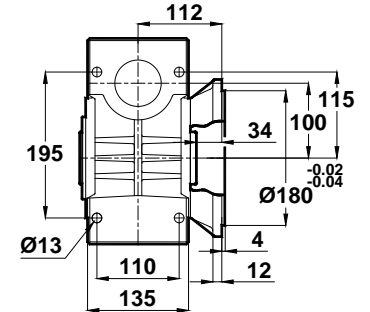
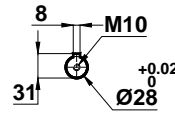
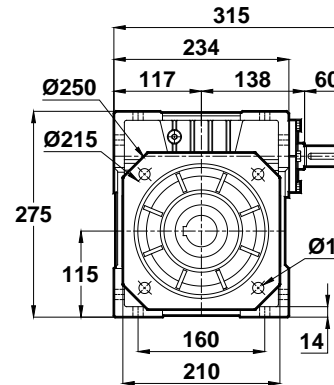

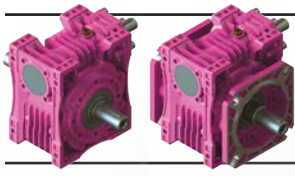

# Ölçü Sayfaları

## Dimension Pages

### Abmessungsseiten

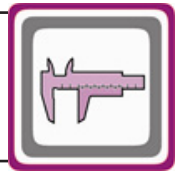

-Mil ucu çekirme deliği DIN 332 sayfa 2 / Tapped center hole to DIN 332, sheet 2 / Zentrierung mit Gewinde DIN 332, Blatt 2

#### ET100.04

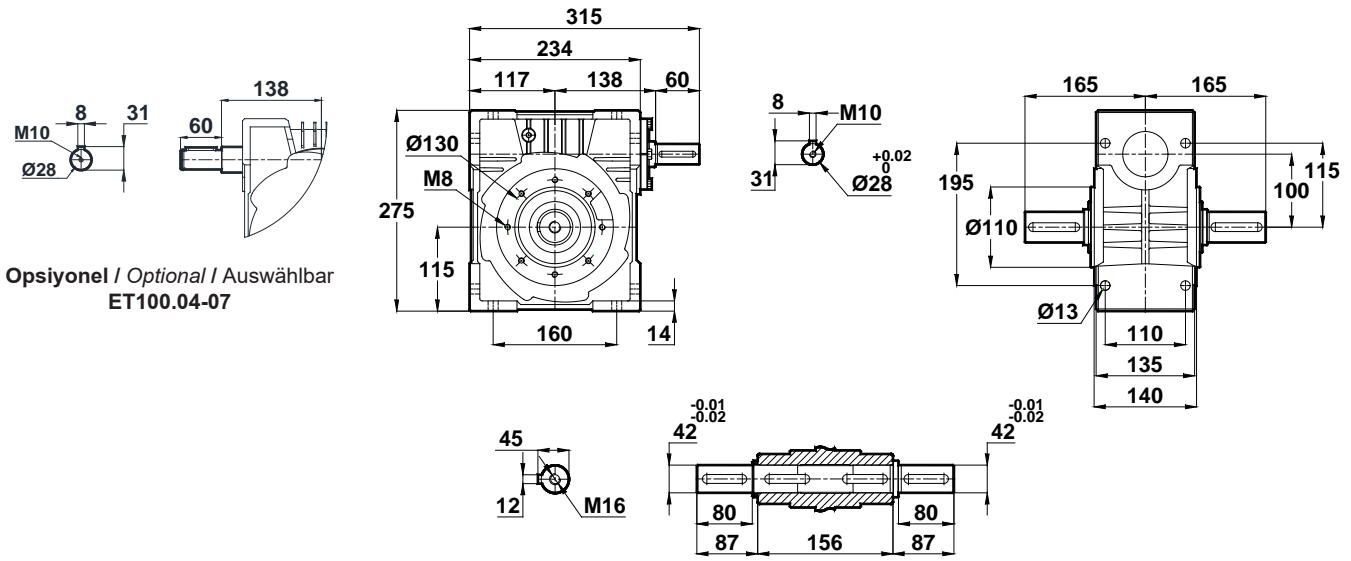

Opsiyonel / Optional / Auswählbar  
ET100.04-07

#### ET100.05

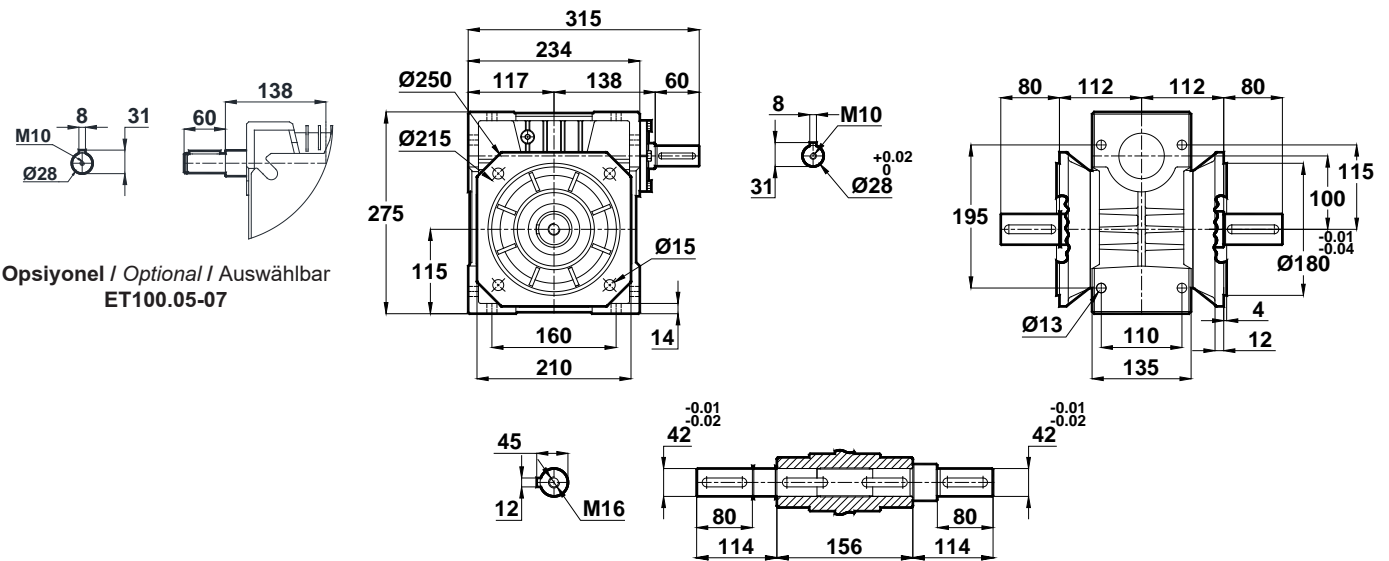

Opsiyonel / Optional / Auswählbar  
ET100.05-07



# Ölçü Sayfaları

## Dimension Pages

### Abmessungsseiten



-Mil ucu çekirme deliği DIN 332 sayfa 2 / Tapped center hole to DIN 332, sheet 2 / Zentrierung mit Gewinde DIN 332, Blatt 2

ET100.08

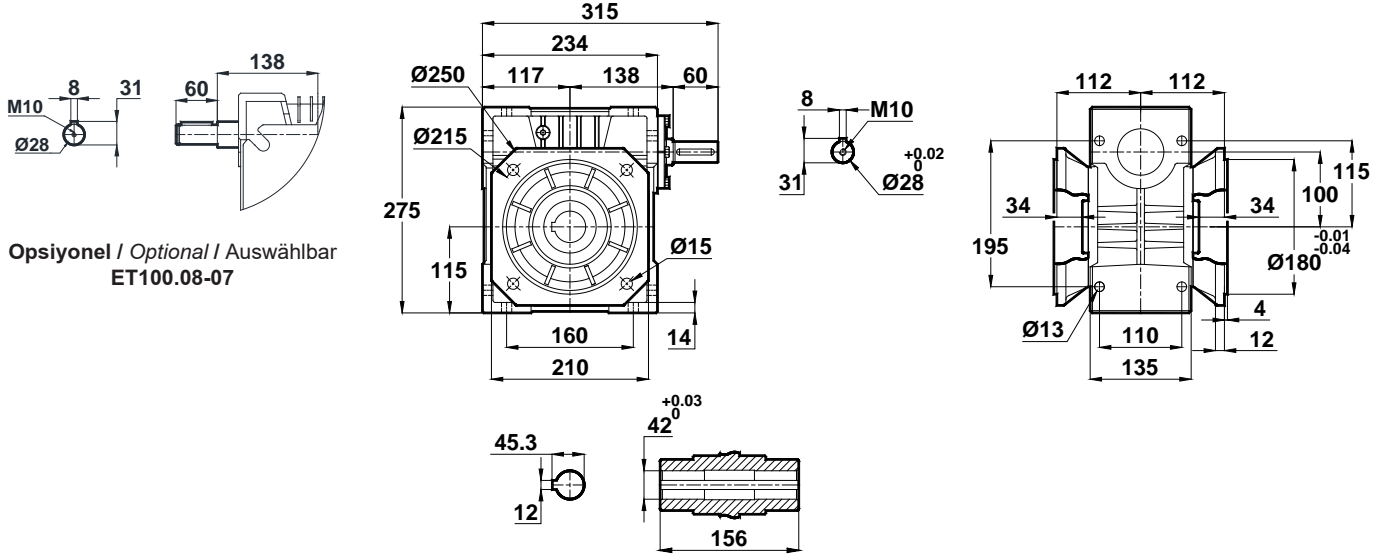

Opsiyonel / Optional / Auswählbar  
ET100.08-07

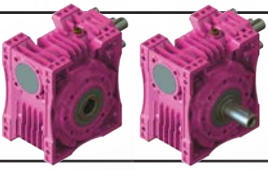

# Ölçü Sayfaları

## Dimension Pages

### Abmessungsseiten

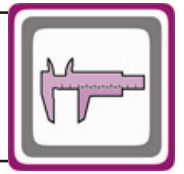

-Mil ucu çekirme deliği DIN 332 sayfa 2 / Tapped center hole to DIN 332, sheet 2 / Zentrierung mit Gewinde DIN 332, Blatt 2

#### ET125.00

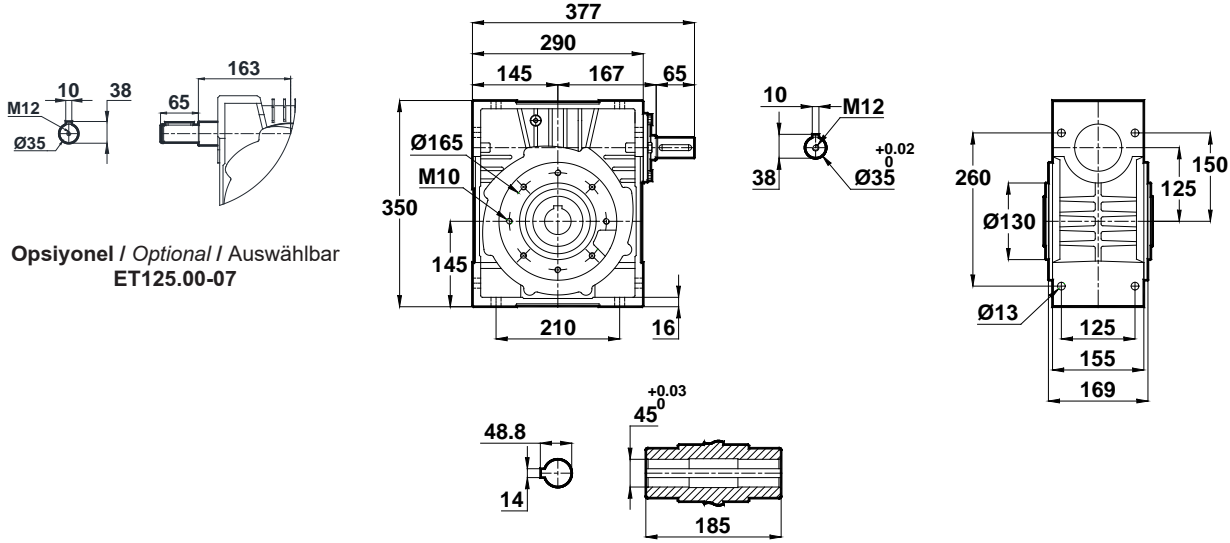

Opsiyonel / Optional / Auswählbar  
ET125.00-07

#### ET125.01

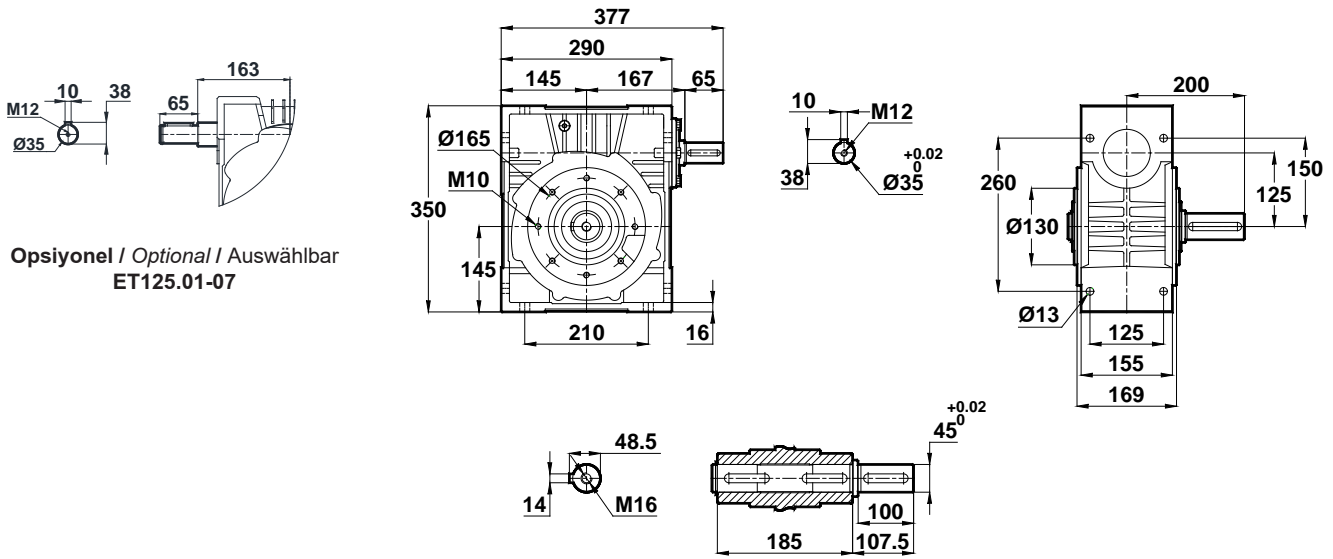

Opsiyonel / Optional / Auswählbar  
ET125.01-07

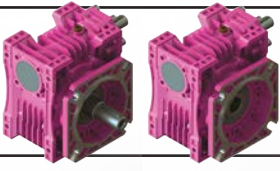

# Ölçü Sayfaları

## Dimension Pages

### Abmessungsseiten



-Mil ucu çekirme deliği DIN 332 sayfa 2 / Tapped center hole to DIN 332, sheet 2 / Zentrierung mit Gewinde DIN 332, Blatt 2

#### ET125.02

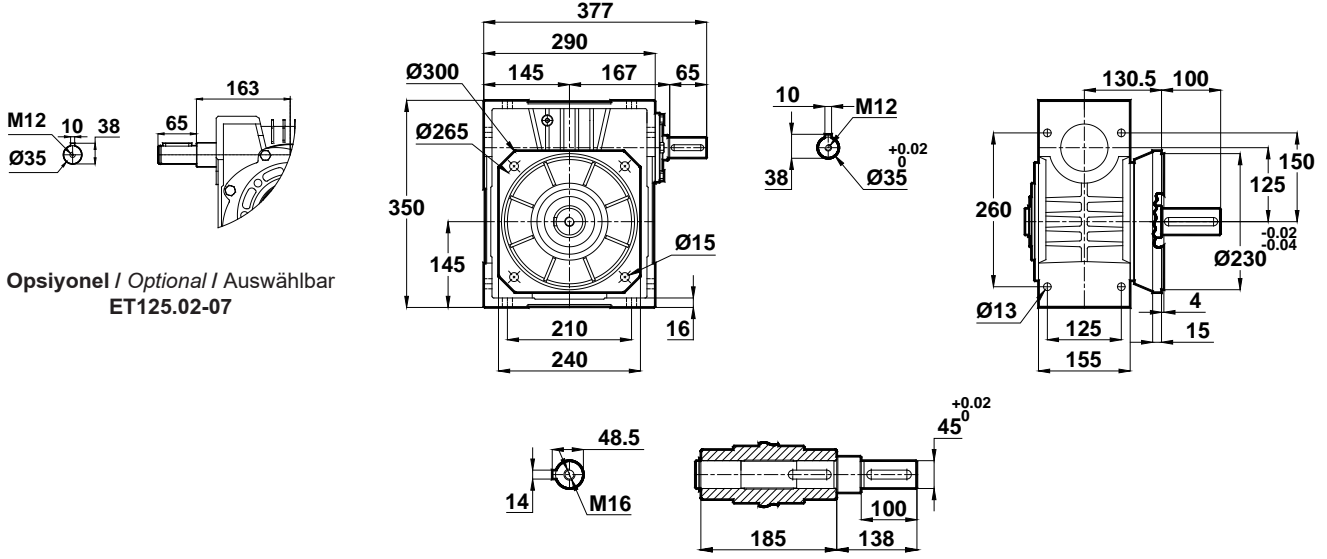

Opsiyonel / Optional / Auswählbar  
ET125.02-07

#### ET125.03

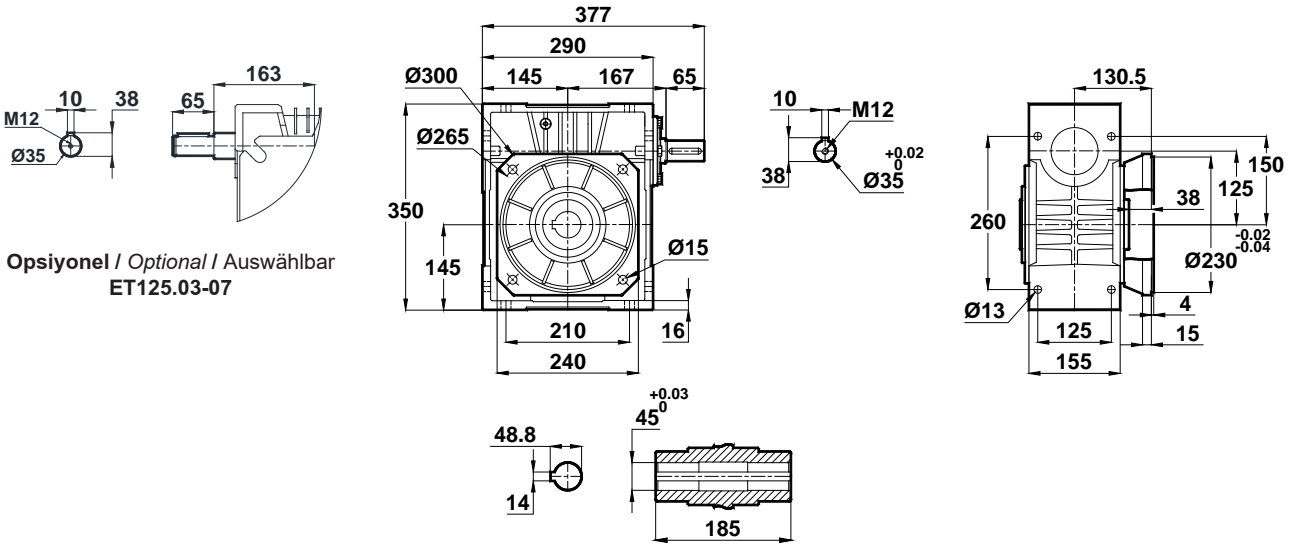

Opsiyonel / Optional / Auswählbar  
ET125.03-07

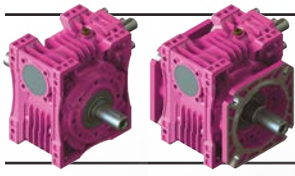

# Ölçü Sayfaları

## Dimension Pages

### Abmessungsseiten



-Mil ucu çekirme deliği DIN 332 sayfa 2 / Tapped center hole to DIN 332, sheet 2 / Zentrierung mit Gewinde DIN 332, Blatt 2

#### ET125.04

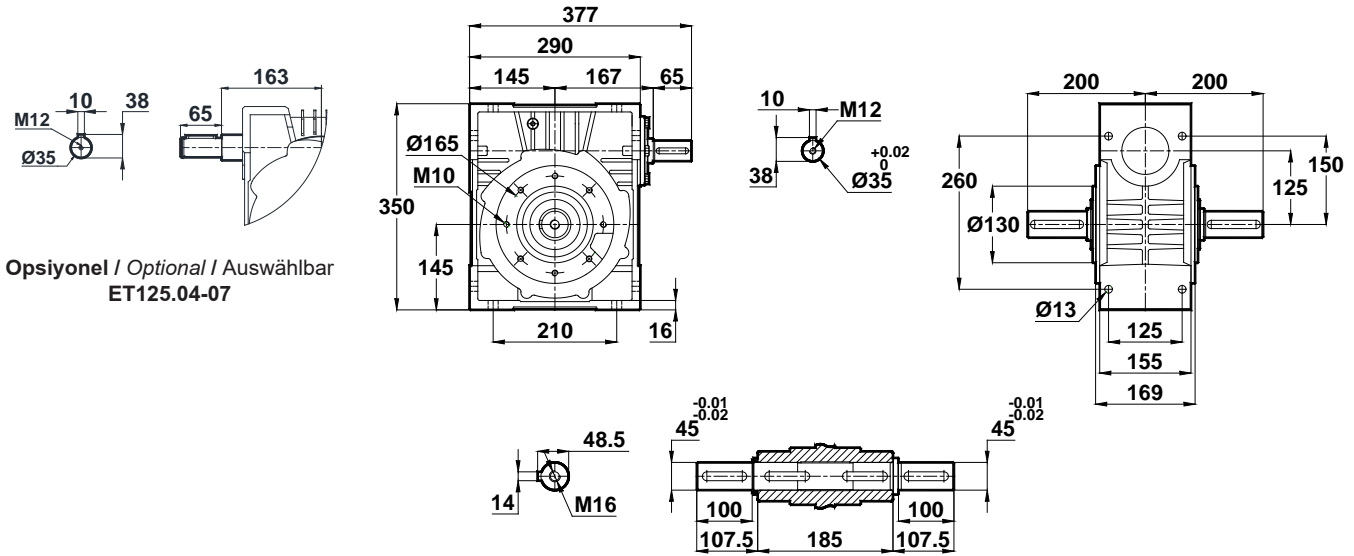

Opsiyonel / Optional / Auswählbar  
ET125.04-07

#### ET125.05

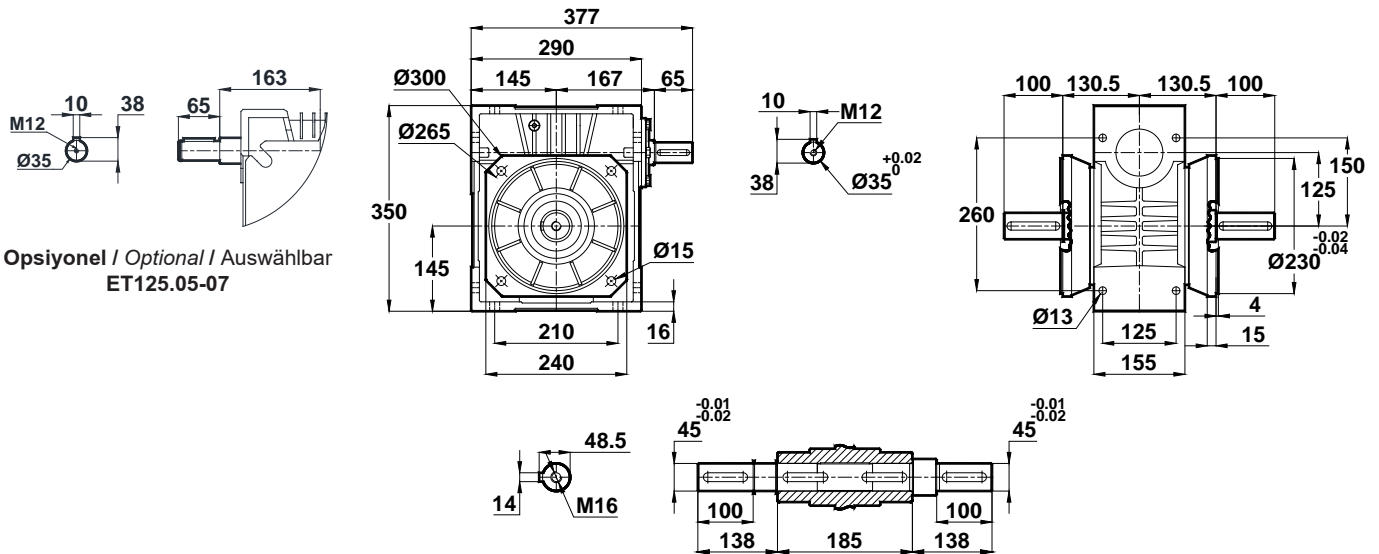

Opsiyonel / Optional / Auswählbar  
ET125.05-07





# Ölçü Sayfaları

## Dimension Pages

### Abmessungsseiten



-Mil ucu çekirme deliği DIN 332 sayfa 2 / Tapped center hole to DIN 332, sheet 2 / Zentrierung mit Gewinde DIN 332, Blatt 2

ET125.08

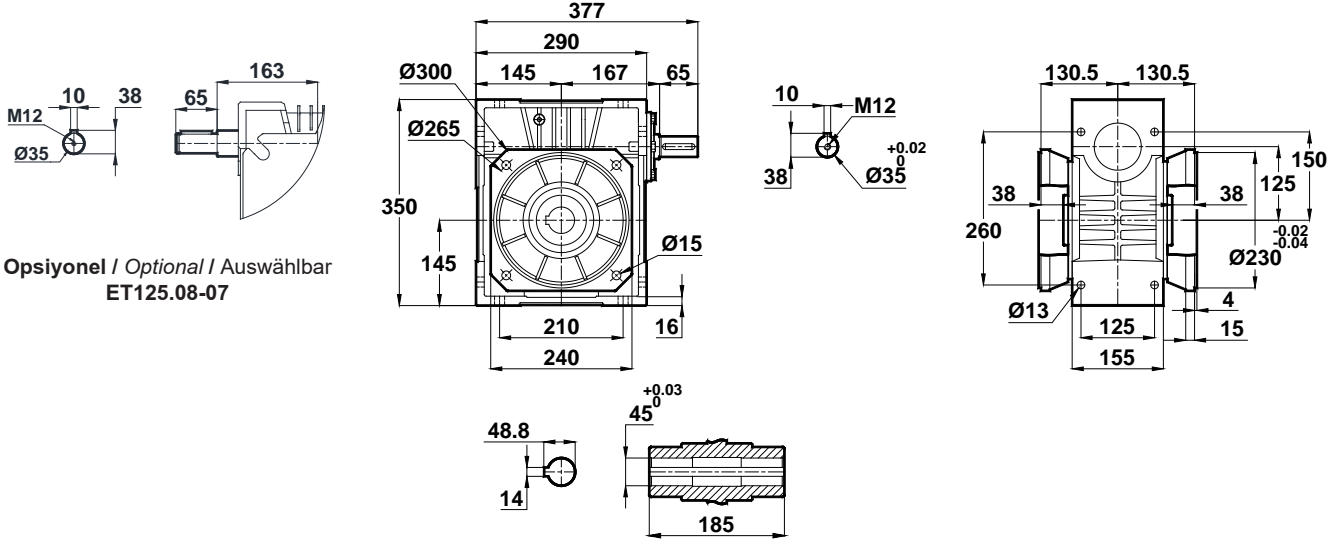

Opsiyonel / Optional / Auswählbar  
ET125.08-07

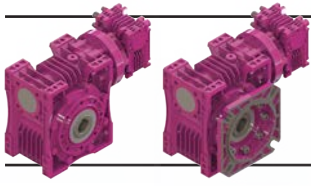

# Ölçü Sayfaları

## Dimension Pages

### Abmessungsseiten



-Mil ucu çekirme deliği DIN 332 sayfa 2 / Tapped center hole to DIN 332, sheet 2 / Zentrierung mit Gewinde DIN 332, Blatt 2

ET040.□ - 030

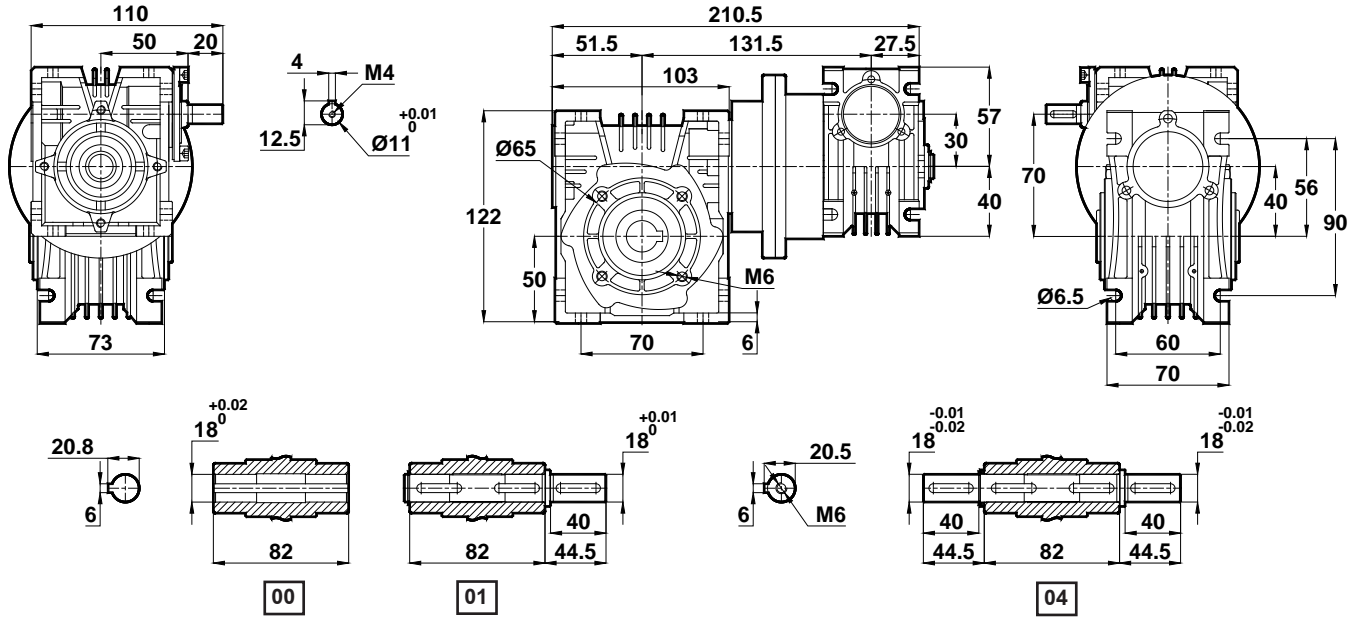

ET040.□ - 030

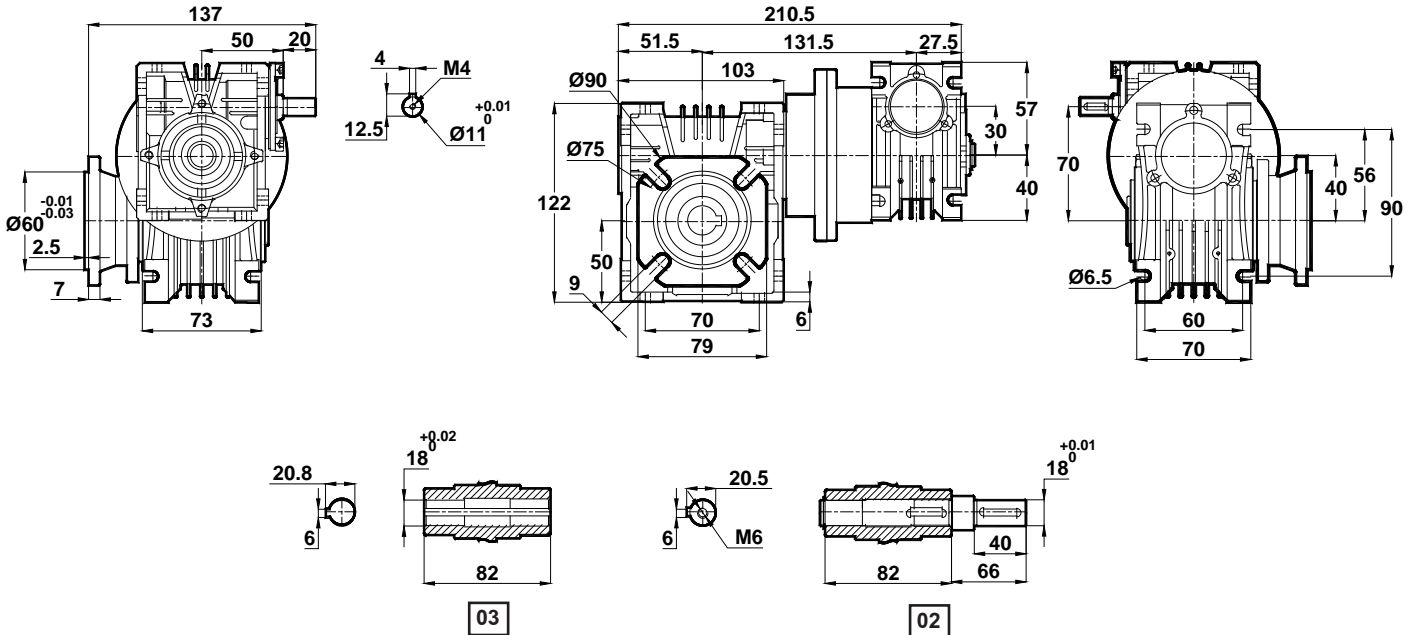

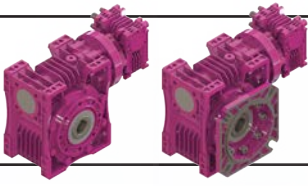

# Ölçü Sayfaları

## Dimension Pages

### Abmessungsseiten



-Mil ucu çekirme deliği DIN 332 sayfa 2 / Tapped center hole to DIN 332, sheet 2 / Zentrierung mit Gewinde DIN 332, Blatt 2

ET050.□ - 030

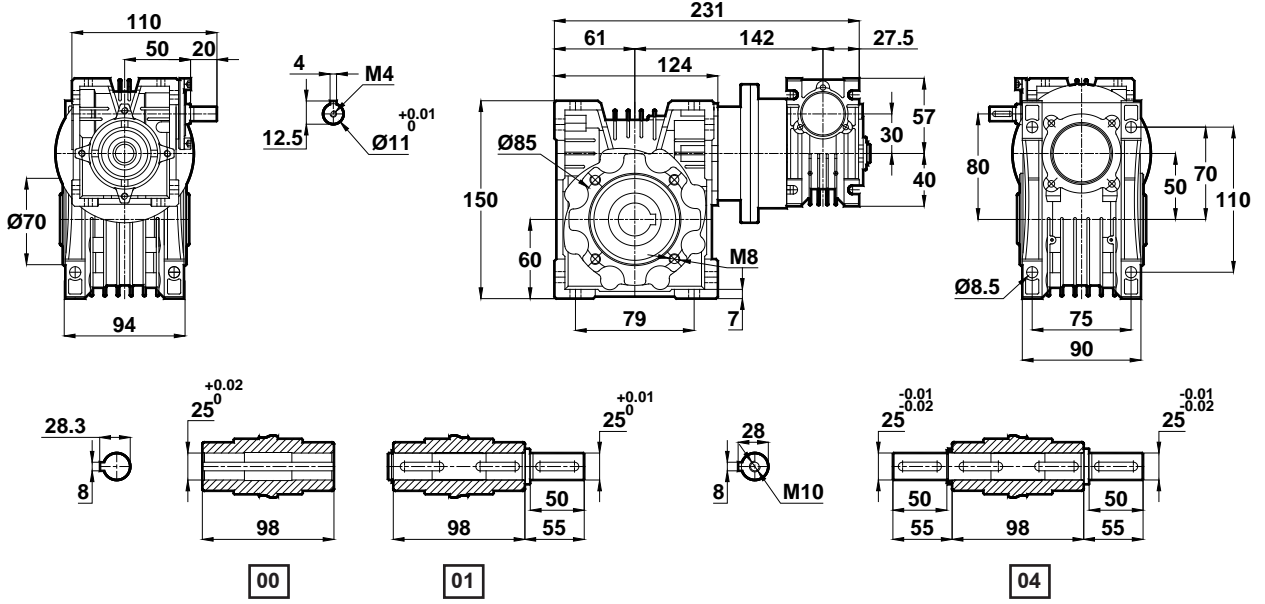

ET050.□ - 030

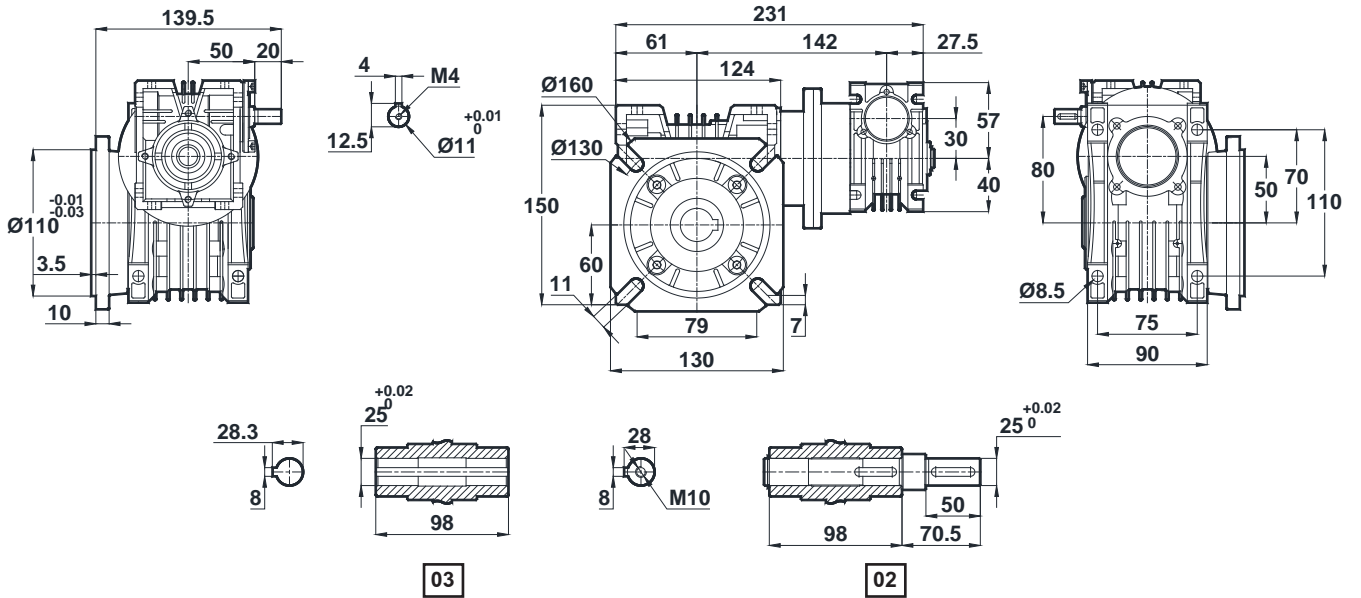

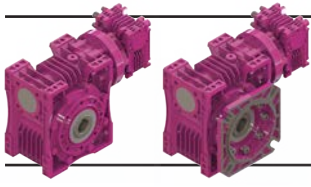

# Ölçü Sayfaları

## Dimension Pages

### Abmessungsseiten

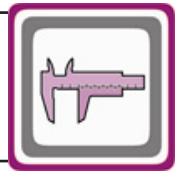

-Mil ucu çektirme deliği DIN 332 sayfa 2 / Tapped center hole to DIN 332, sheet 2 / Zentrierung mit Gewinde DIN 332, Blatt 2

ET063.□ - 030

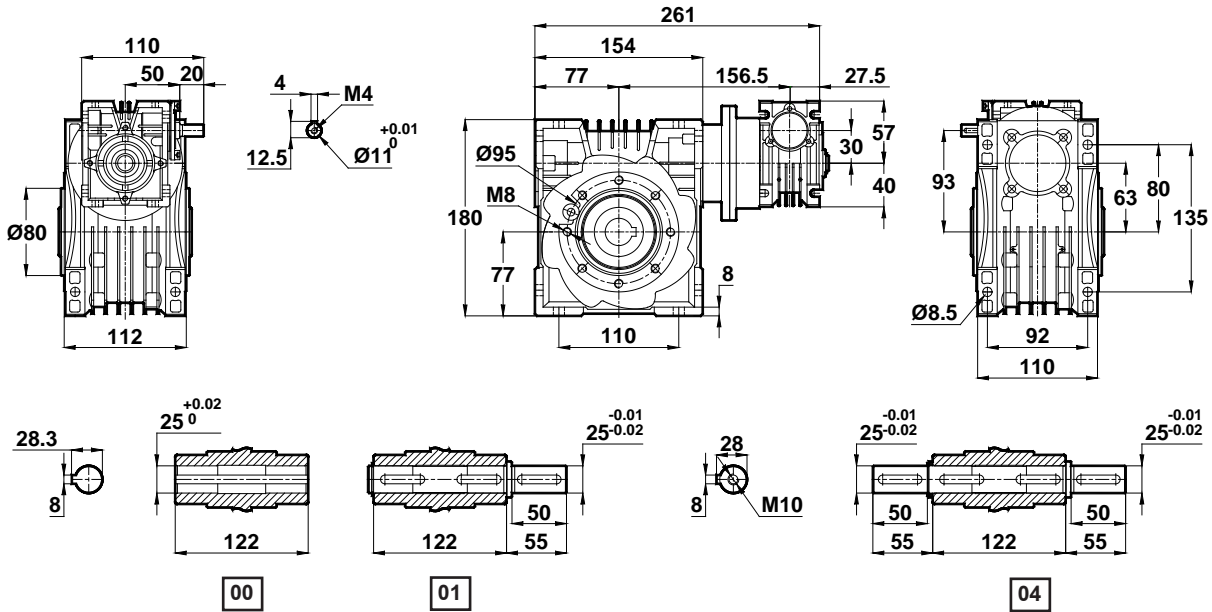

ET063.□ - 030

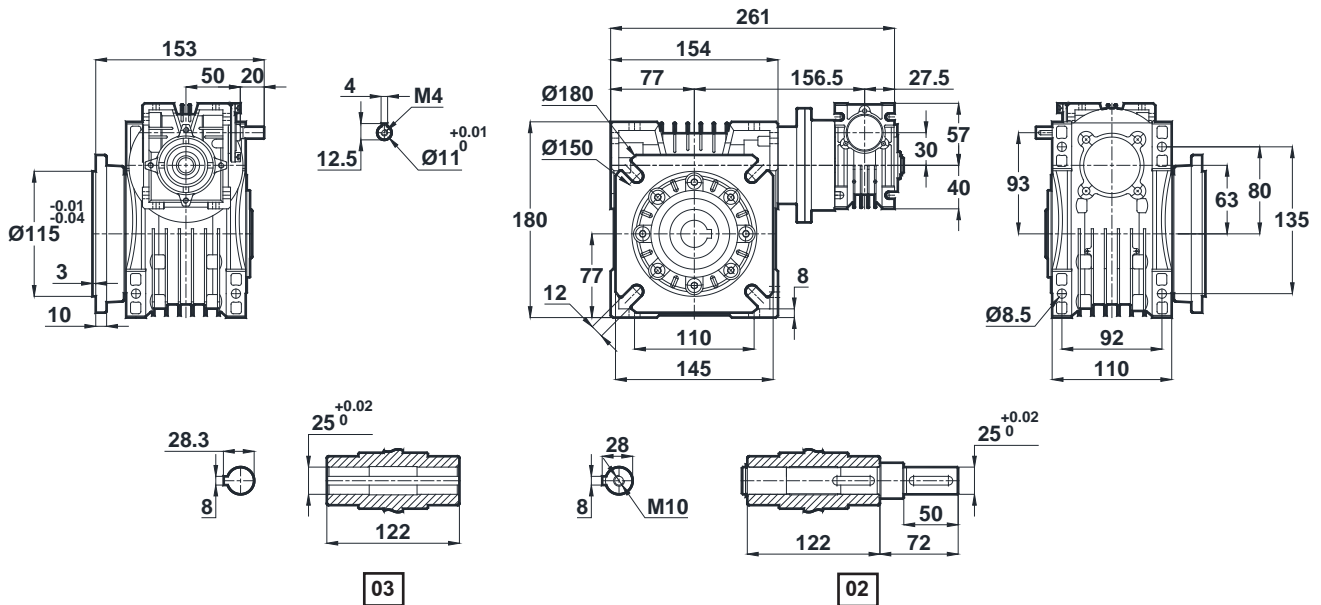

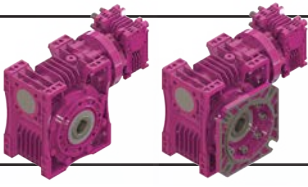

# Ölçü Sayfaları

## Dimension Pages

### Abmessungsseiten



-Mil ucu çekirme deliği DIN 332 sayfa 2 / Tapped center hole to DIN 332, sheet 2 / Zentrierung mit Gewinde DIN 332, Blatt 2

ET075.□ - 040

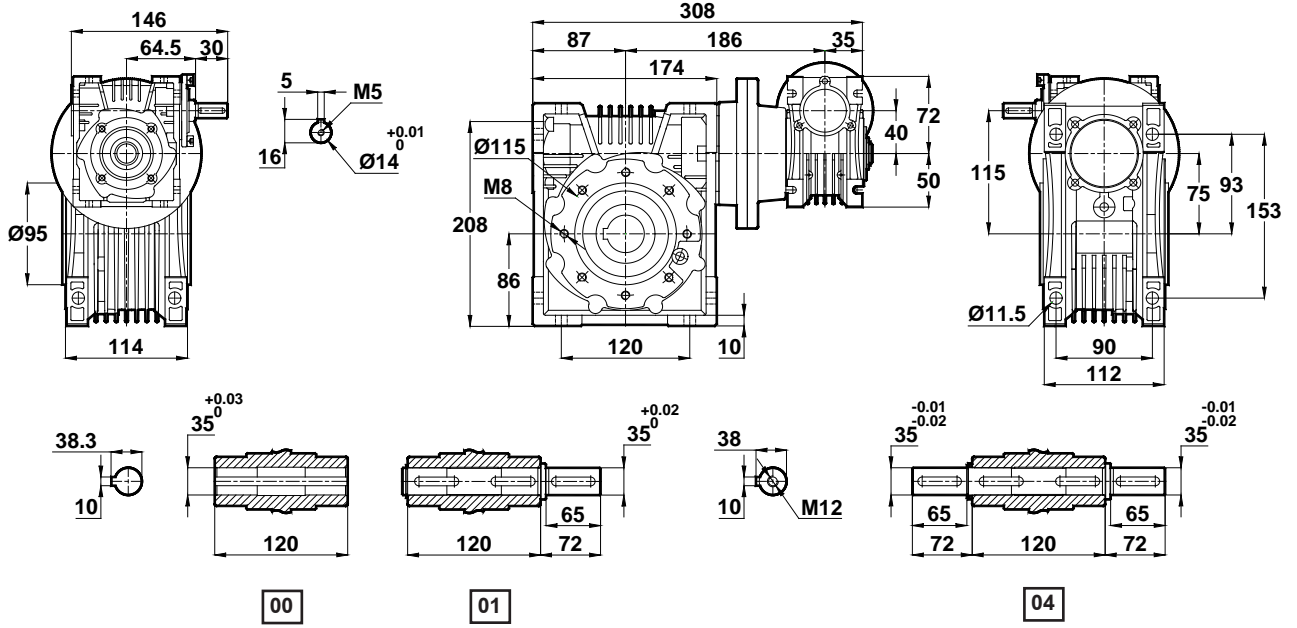

ET075.□ - 040

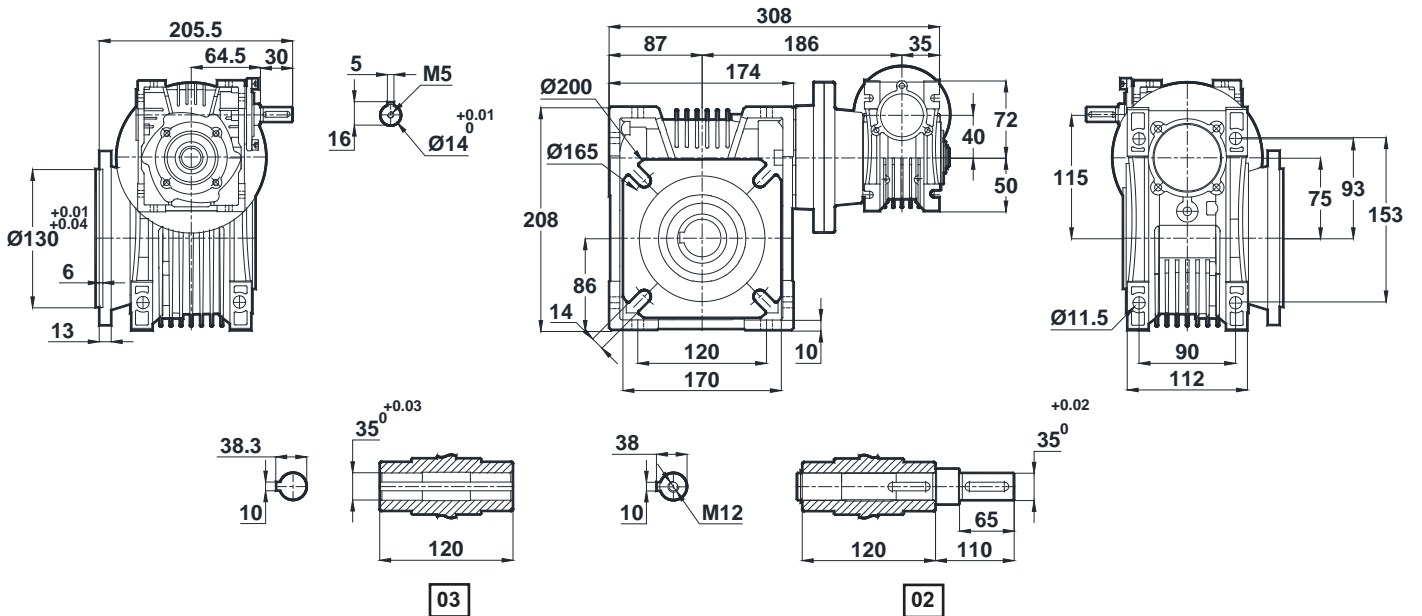

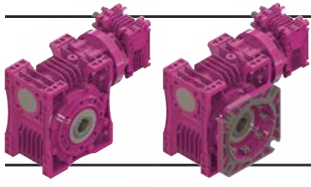

# Ölçü Sayfaları

## Dimension Pages

### Abmessungsseiten



-Mil ucu çekirme deliği DIN 332 sayfa 2 / Tapped center hole to DIN 332, sheet 2 / Zentrierung mit Gewinde DIN 332, Blatt 2

ET080.□ - 040

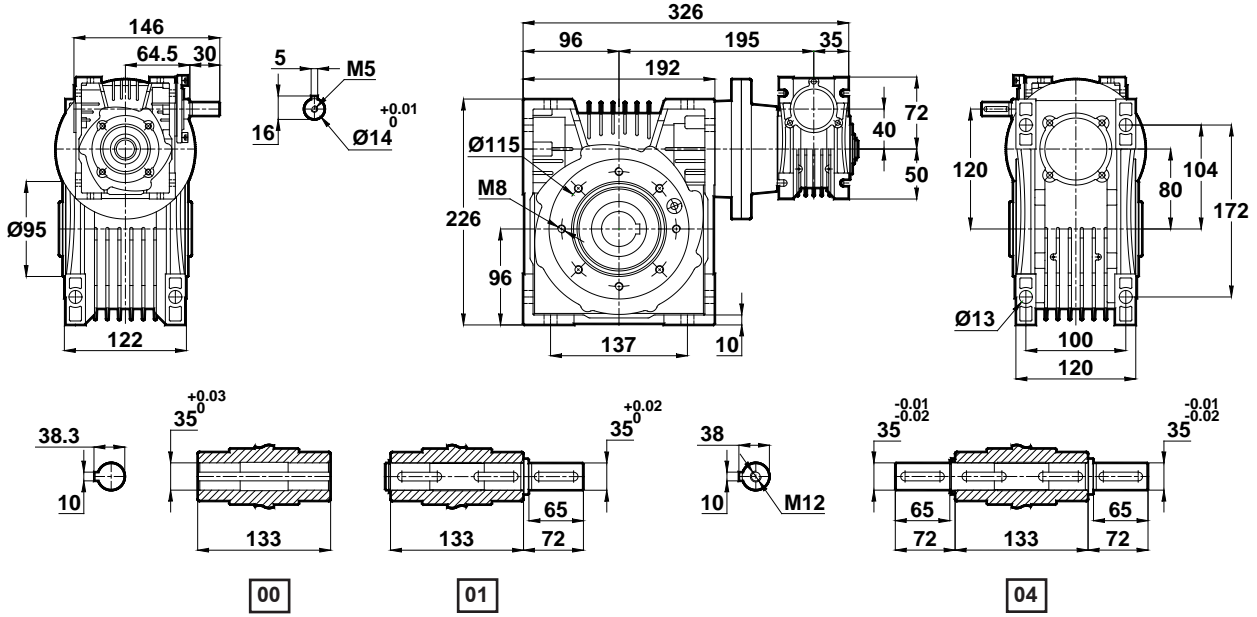

ET080.□ - 040

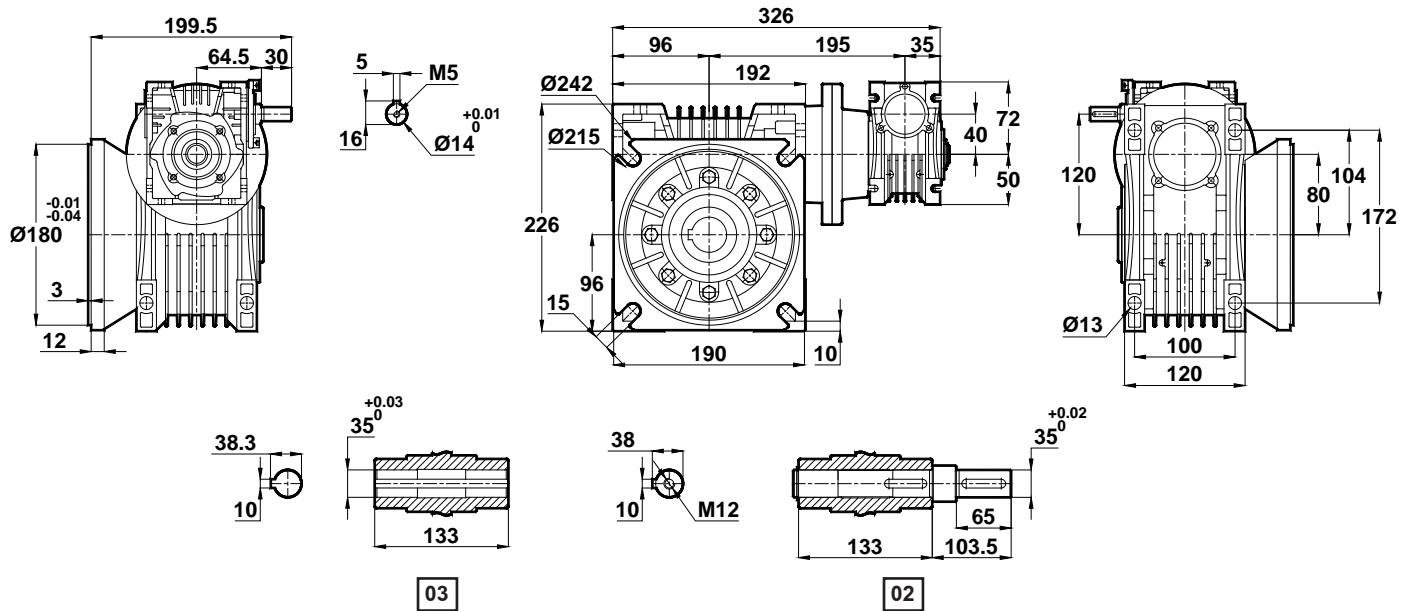

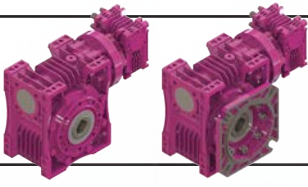

# Ölçü Sayfaları

## Dimension Pages

### Abmessungsseiten



-Mil ucu çekirme deliği DIN 332 sayfa 2 / Tapped center hole to DIN 332, sheet 2 / Zentrierung mit Gewinde DIN 332, Blatt 2

ET100.□ - 050

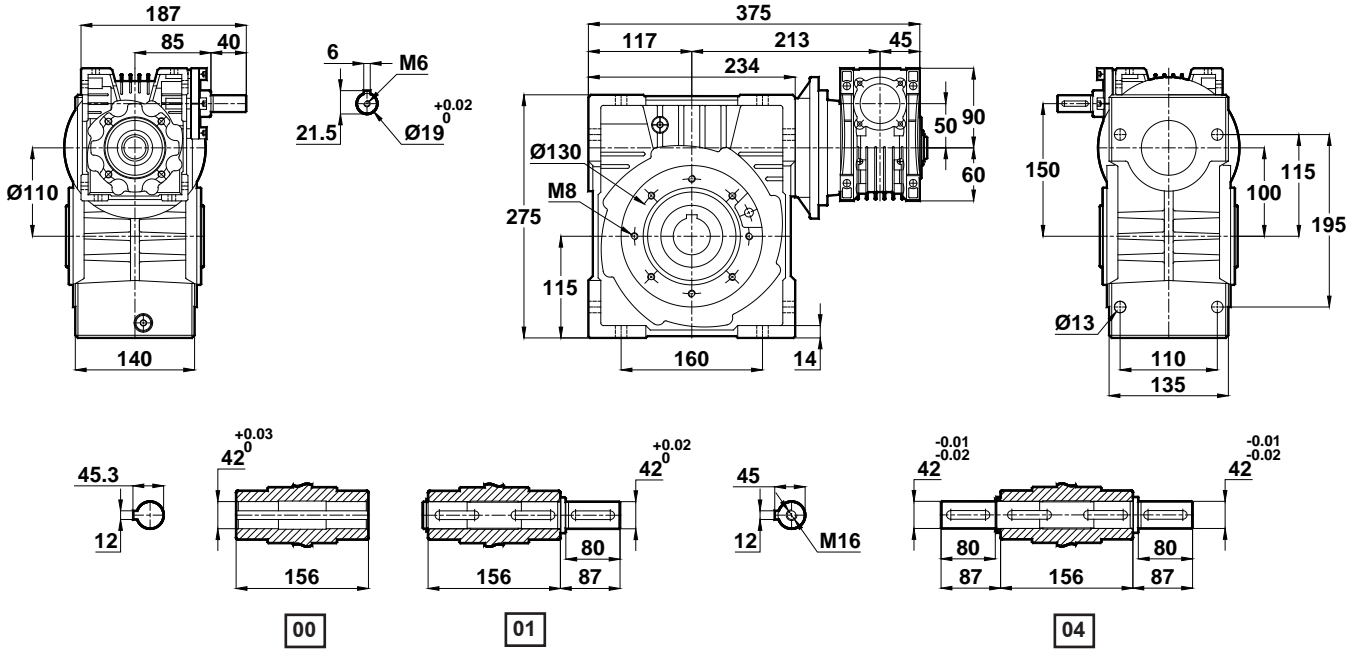

ET100.□ - 050

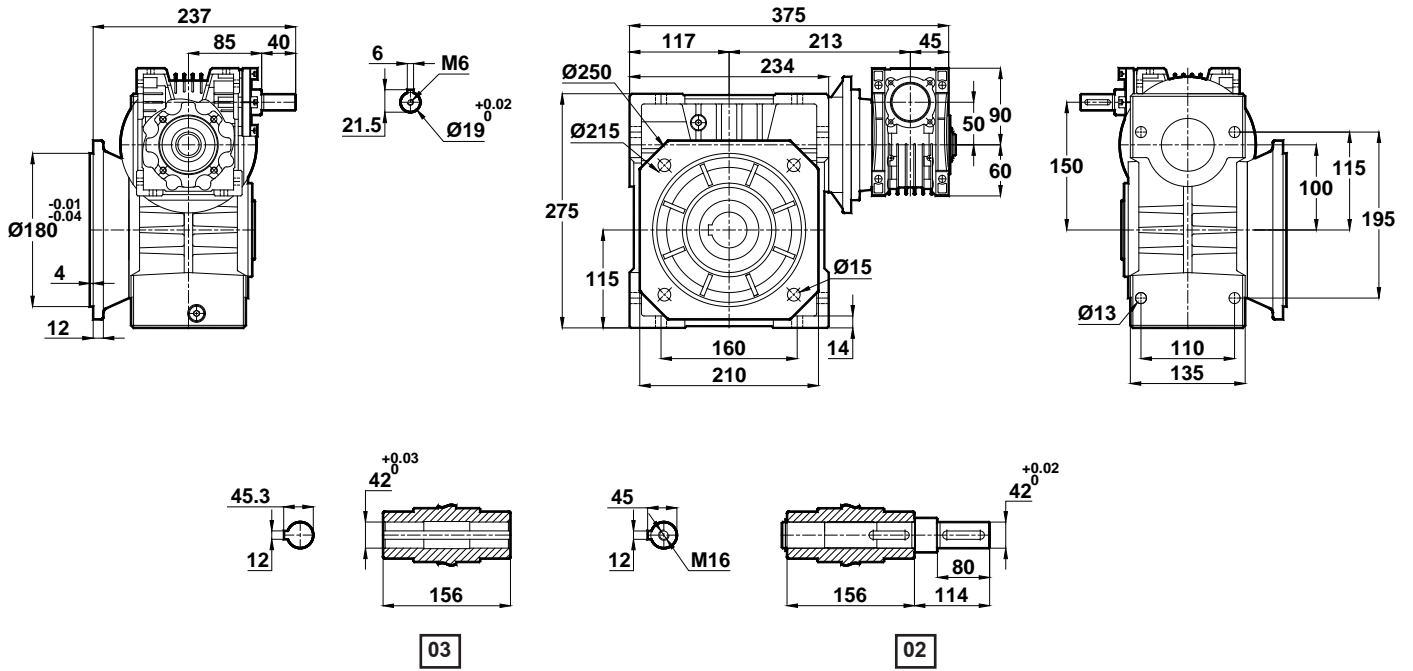

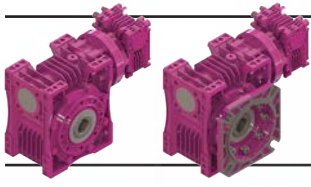

# Ölçü Sayfaları

## Dimension Pages

### Abmessungsseiten

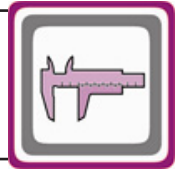

-Mil ucu çekirme deliği DIN 332 sayfa 2 / Tapped center hole to DIN 332, sheet 2 / Zentrierung mit Gewinde DIN 332, Blatt 2

ET125.□ - 063

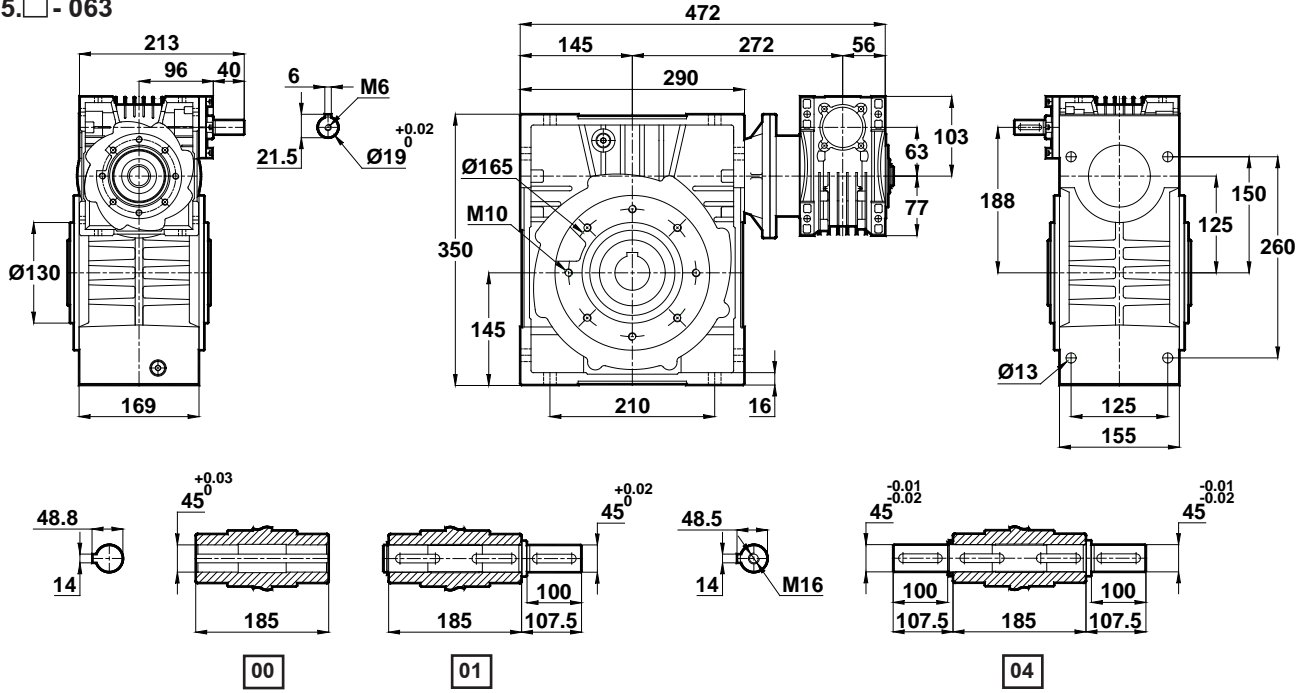

ET125.□ - 063

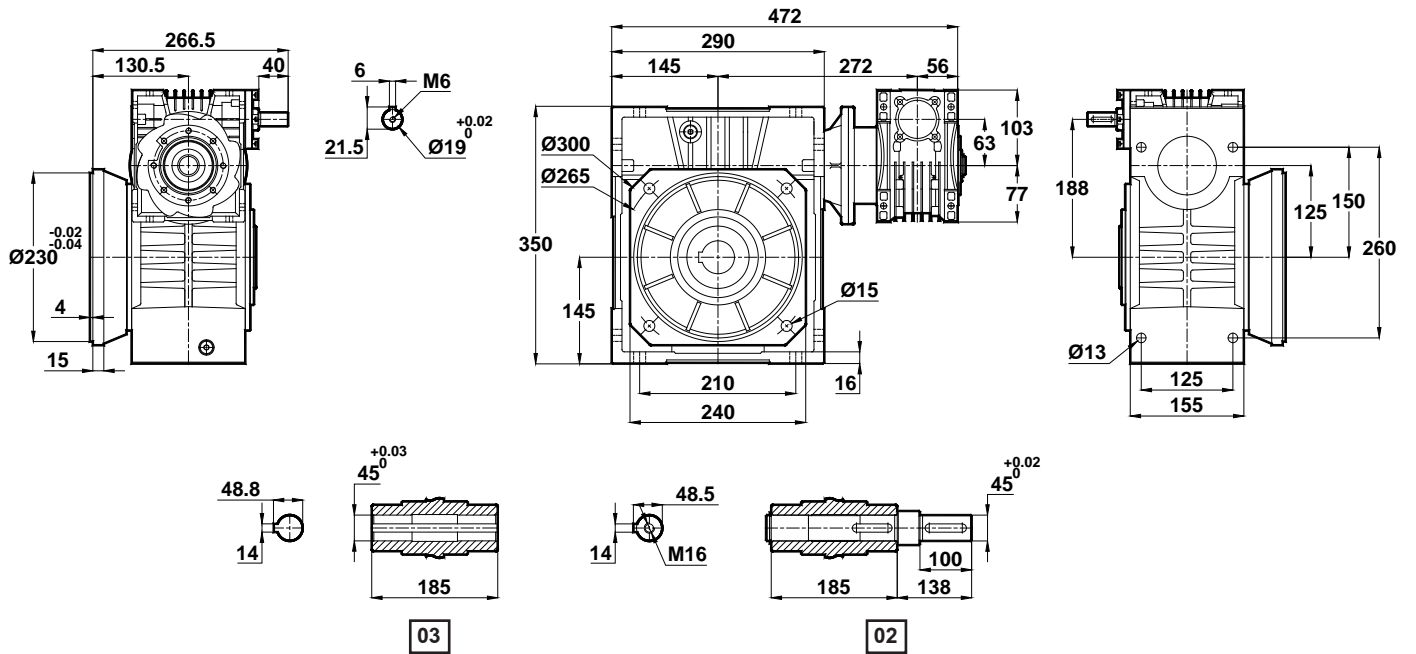



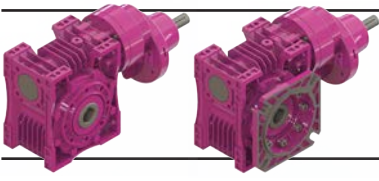

# Ölçü Sayfaları

## Dimension Pages

### Abmessungsseiten

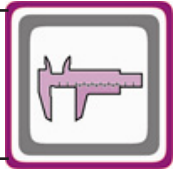

-Mil ucu çekirme deliği DIN 332 sayfa 2 / Tapped center hole to DIN 332, sheet 2 / Zentrierung mit Gewinde DIN 332, Blatt 2

EN050.□ - NT01

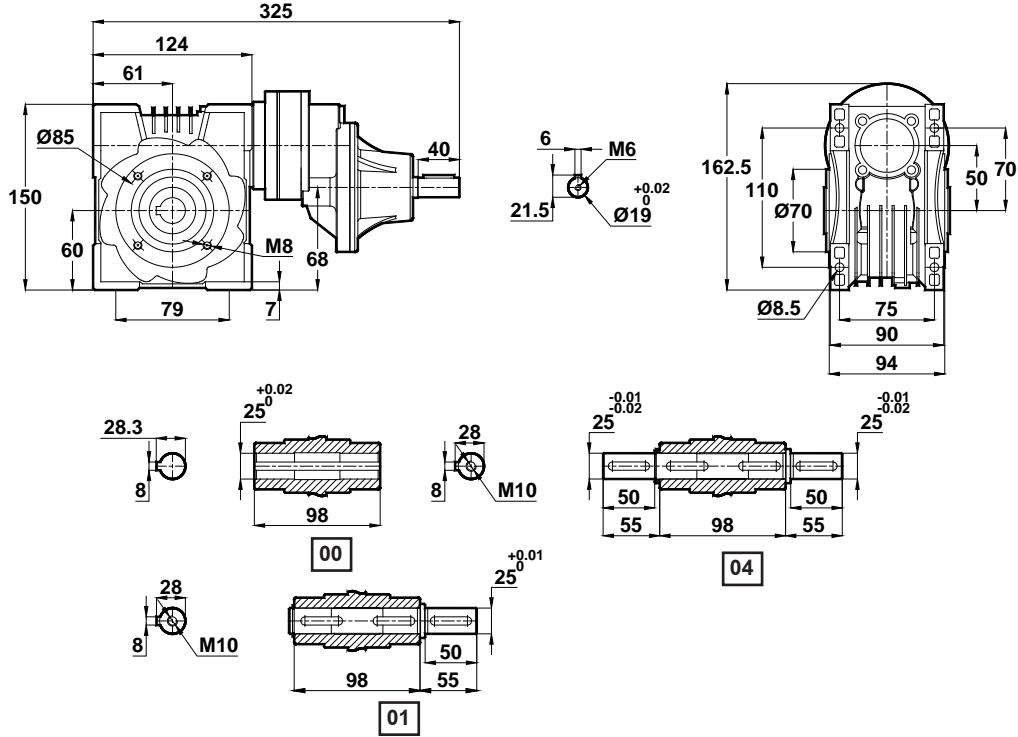

EN050.□ - NT01

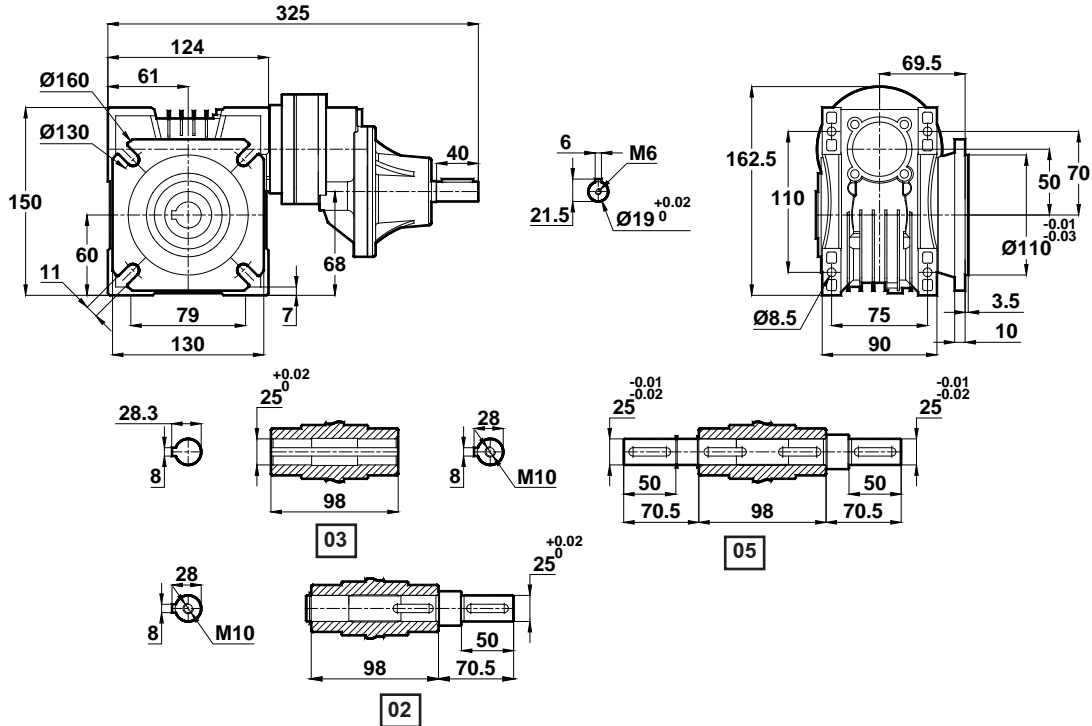

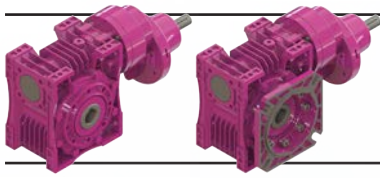

# Ölçü Sayfaları

## Dimension Pages

### Abmessungsseiten

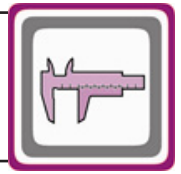

-Mil ucu çekirme deliği DIN 332 sayfa 2 / Tapped center hole to DIN 332, sheet 2 / Zentrierung mit Gewinde DIN 332, Blatt 2

EN063.□ - NT01

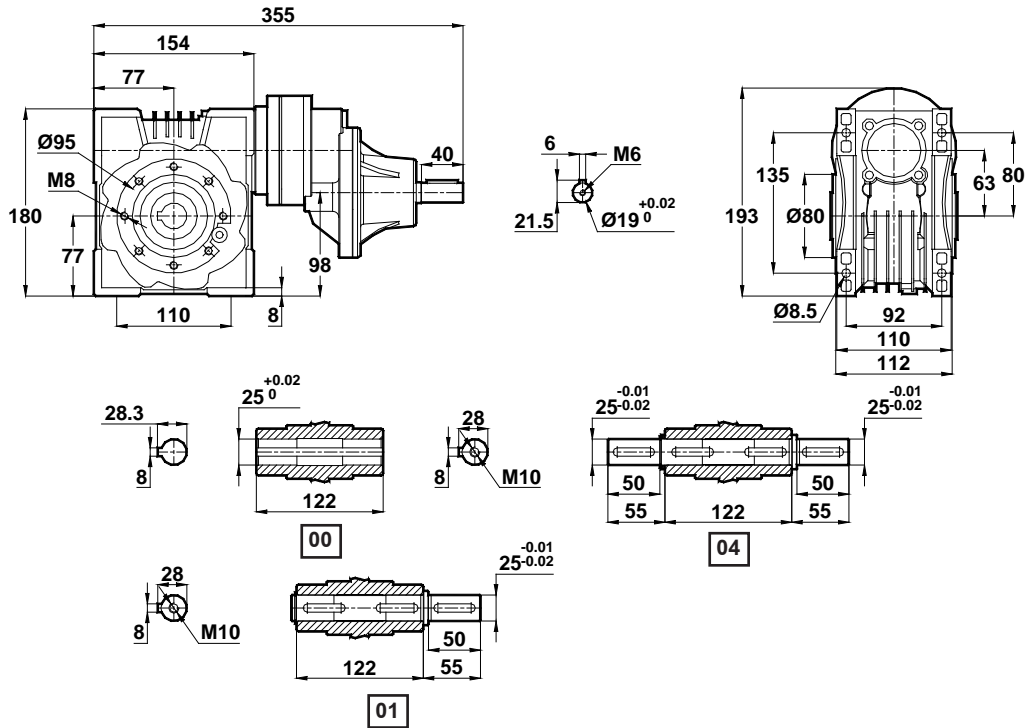

EN063.□ - NT01

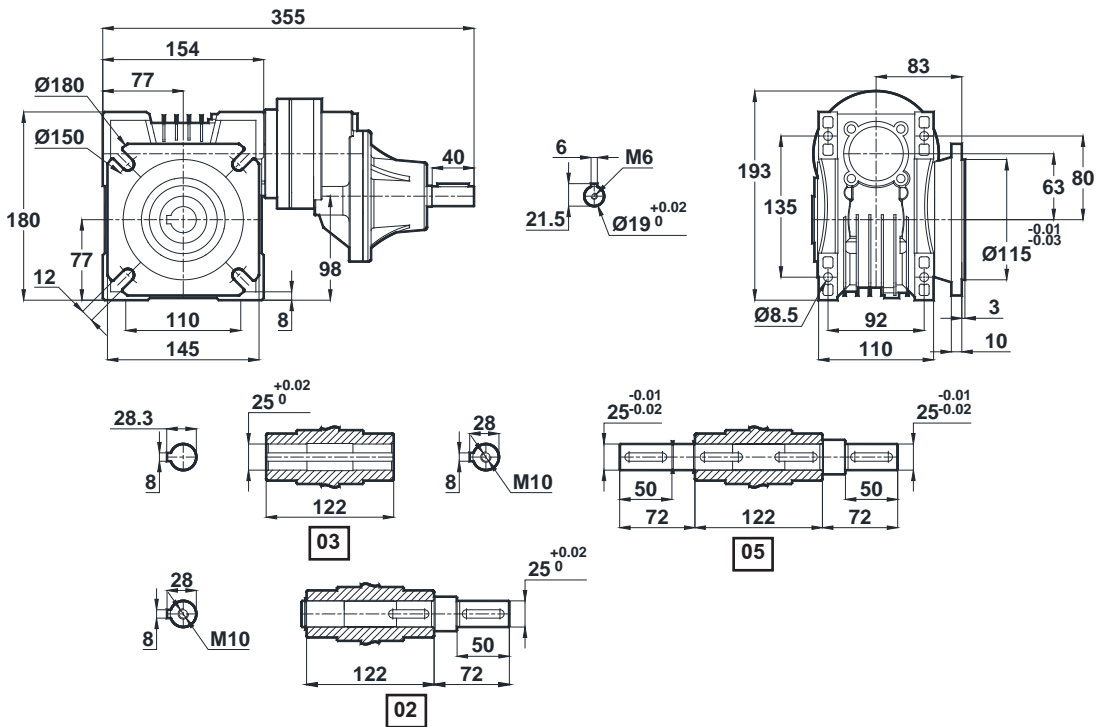

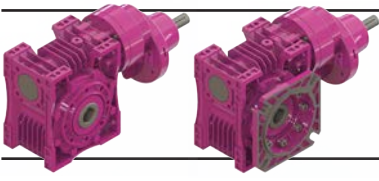

# Ölçü Sayfaları

## Dimension Pages

### Abmessungsseiten

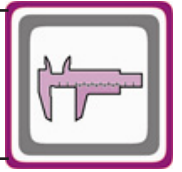

-Mil ucu çekirme deliği DIN 332 sayfa 2 / Tapped center hole to DIN 332, sheet 2 / Zentrierung mit Gewinde DIN 332, Blatt 2

EN075.□ - NT11

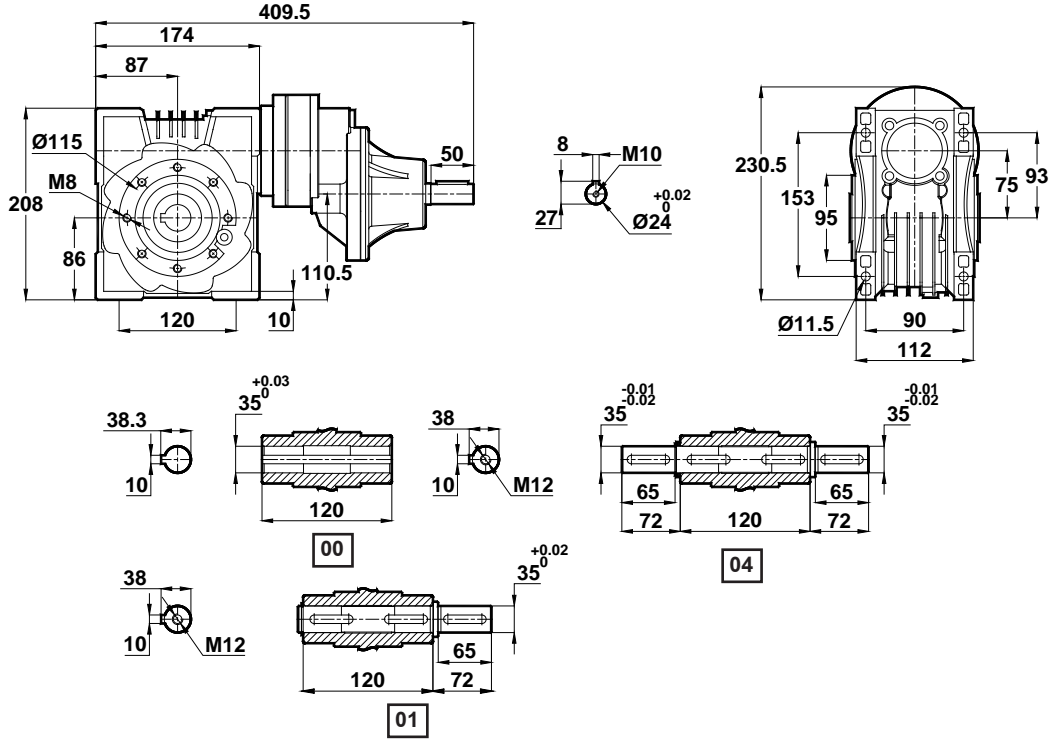

EN075.□ - NT11

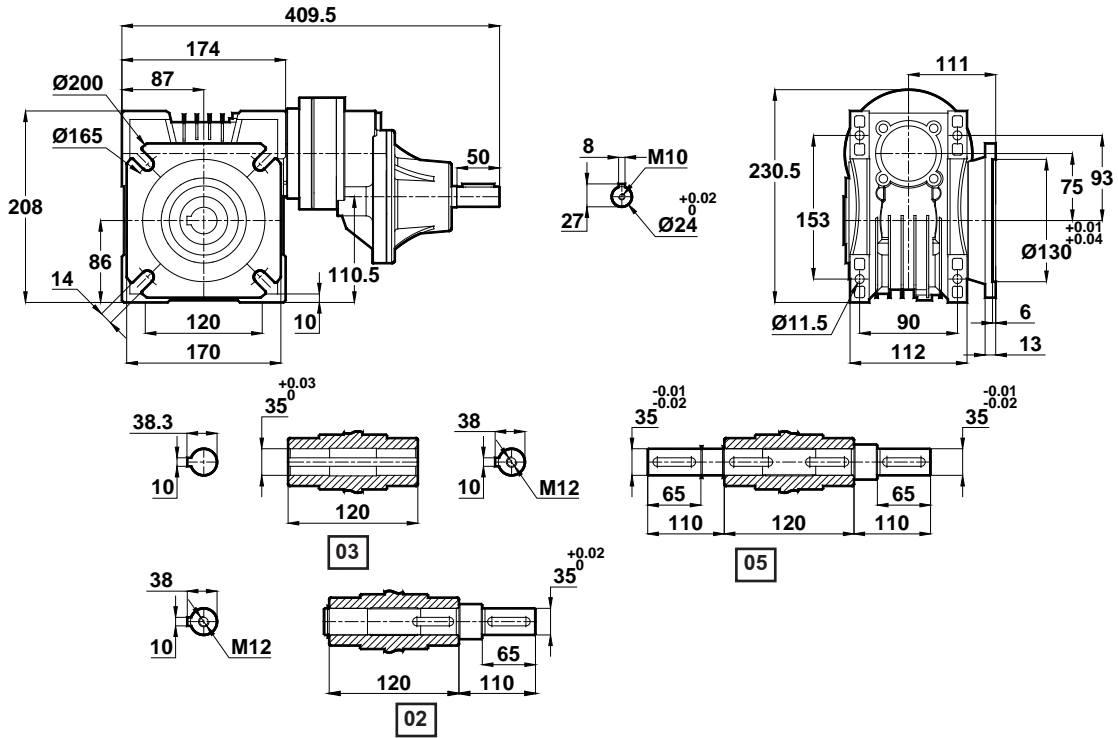

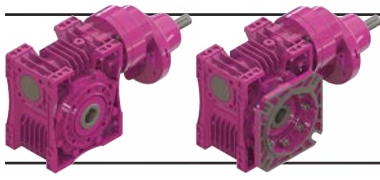

# Ölçü Sayfaları

## Dimension Pages

### Abmessungsseiten

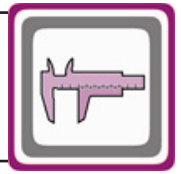

-Mil ucu çekirme deliği DIN 332 sayfa 2 / Tapped center hole to DIN 332, sheet 2 / Zentrierung mit Gewinde DIN 332, Blatt 2

EN080.□ - NT11

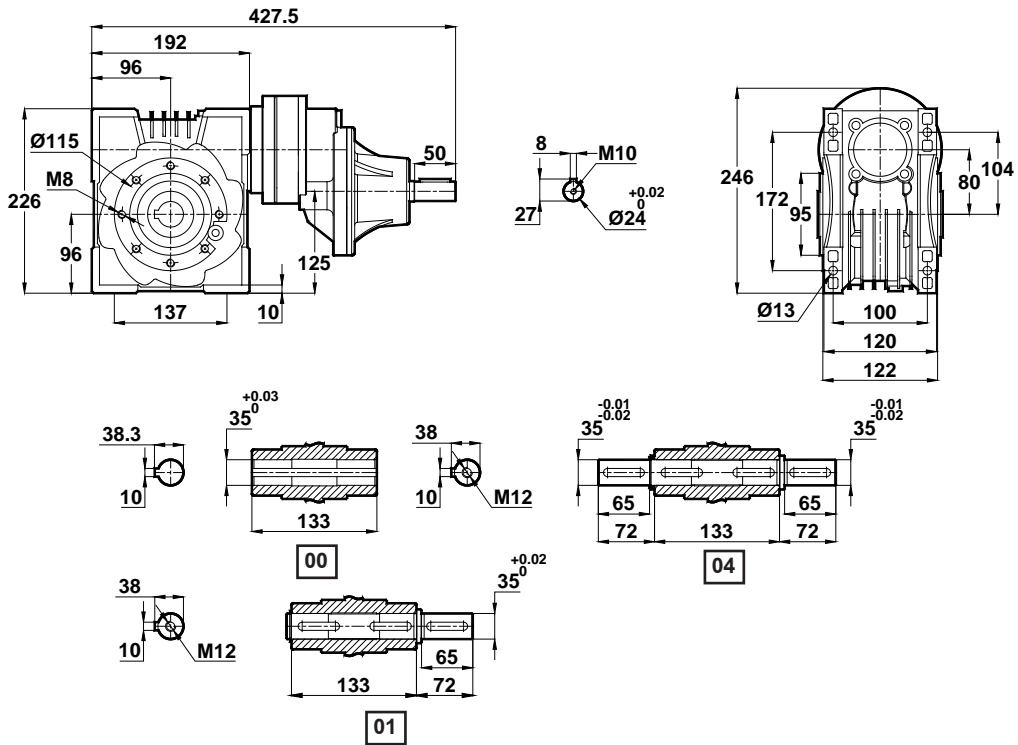

EN080.□ - NT11

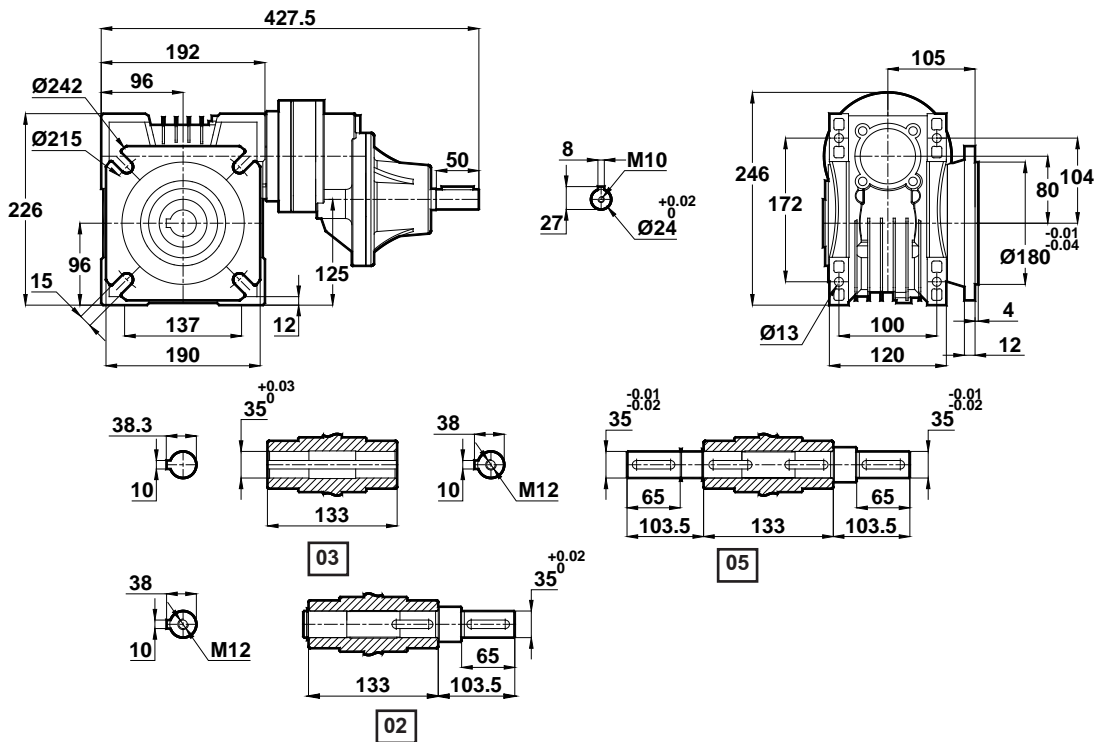

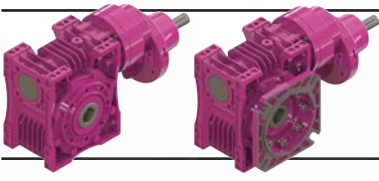

# Ölçü Sayfaları

## Dimension Pages

### Abmessungsseiten



-Mil ucu çekirme deliği DIN 332 sayfa 2 / Tapped center hole to DIN 332, sheet 2 / Zentrierung mit Gewinde DIN 332, Blatt 2

EN100.□ - NT11

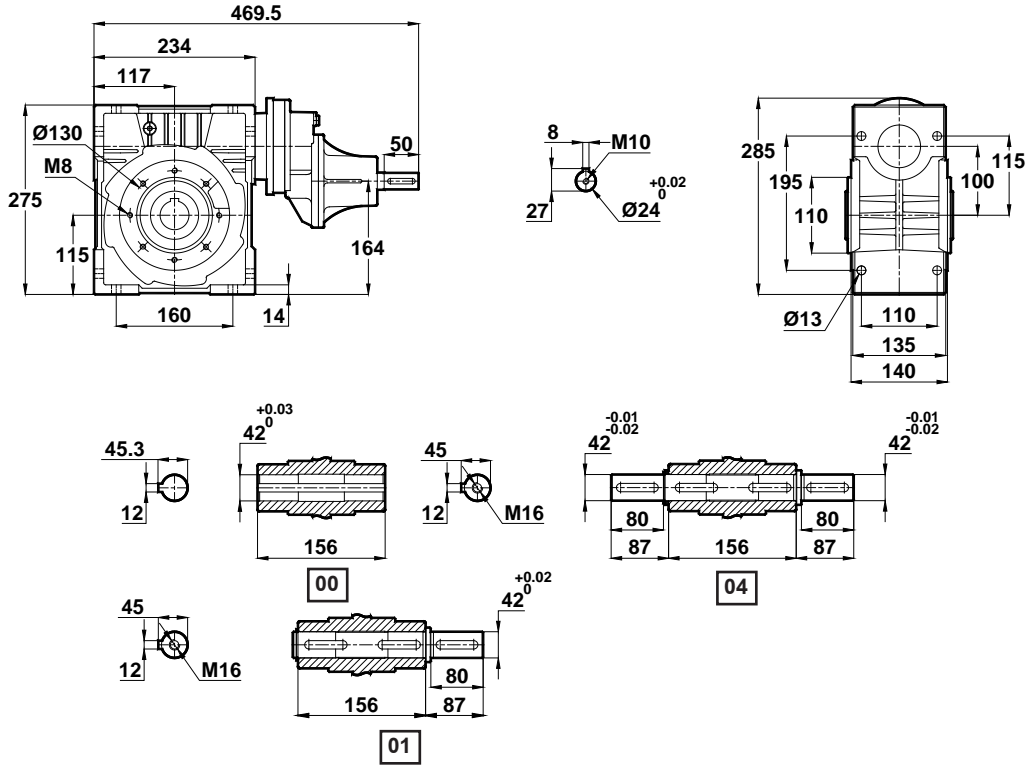

EN100.□ - NT11

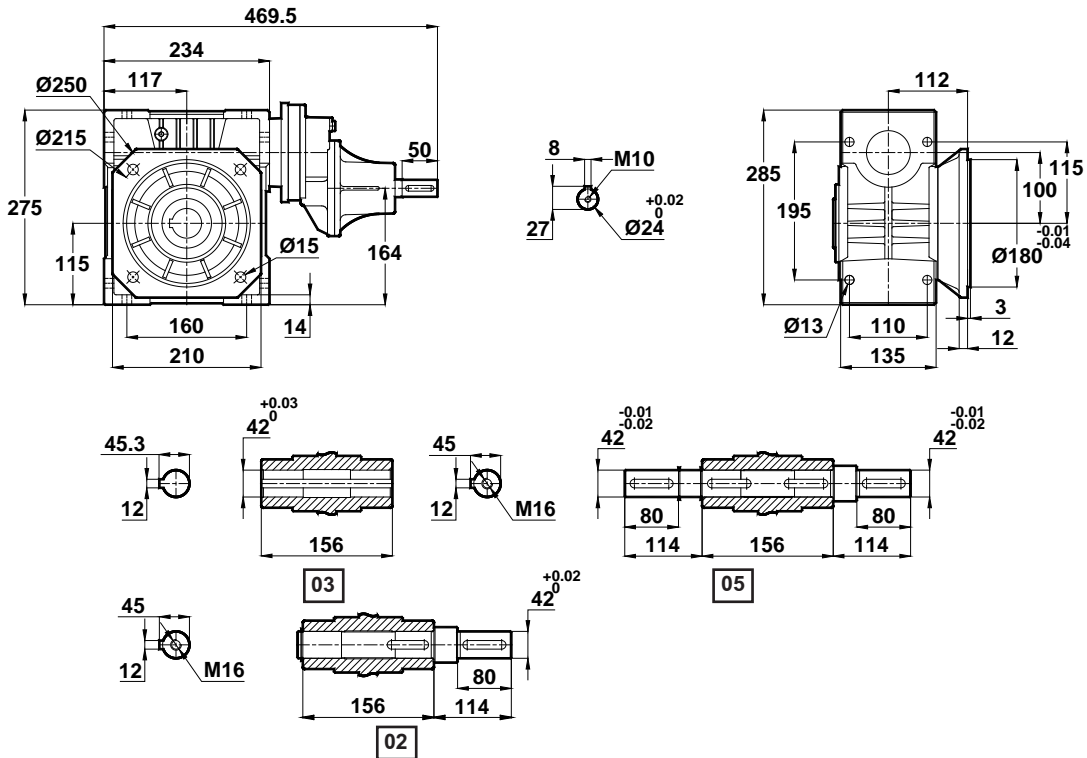

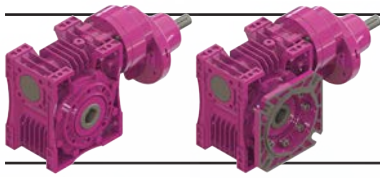

# Ölçü Sayfaları

## Dimension Pages

### Abmessungsseiten

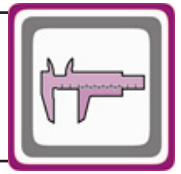

-Mil ucu çekirme deliği DIN 332 sayfa 2 / Tapped center hole to DIN 332, sheet 2 / Zentrierung mit Gewinde DIN 332, Blatt 2

EN125.□ - NT21

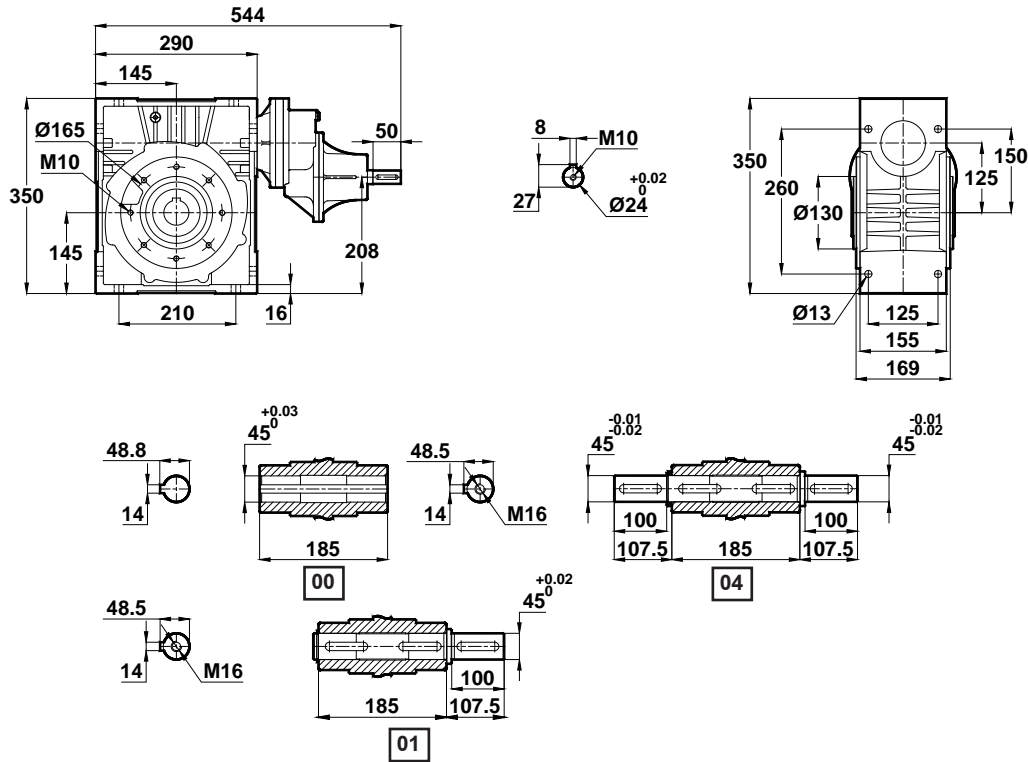

EN125.□ - NT21

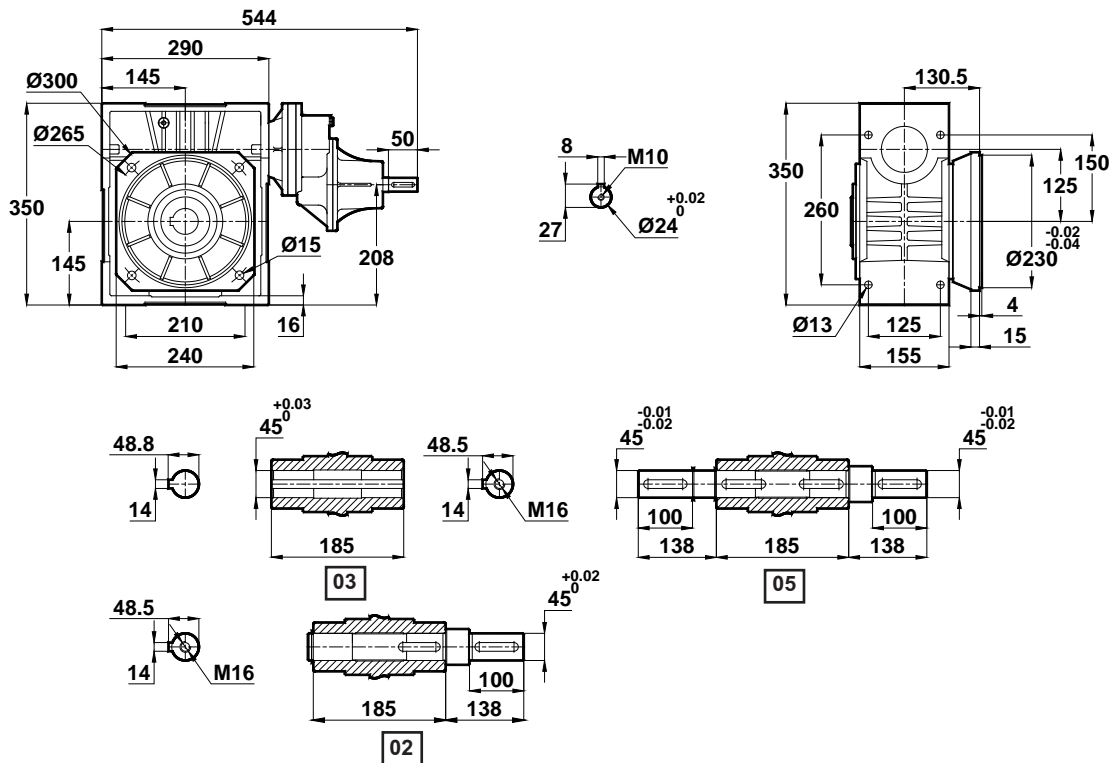

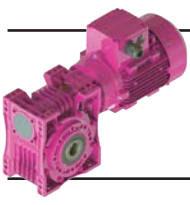

# Ölçü Sayfaları

## Dimension Pages

### Abmessungsseiten

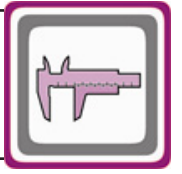

Mil Flanş Ağırlıkları / Shaft and Flange Weights / Gewichte von Wellen und Flanschen

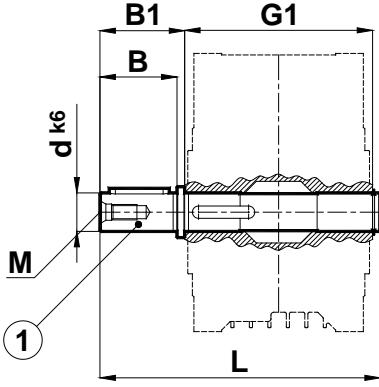

Ex.xxx.04

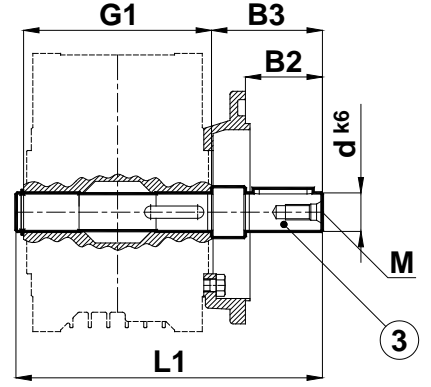

Ex.xxx.05

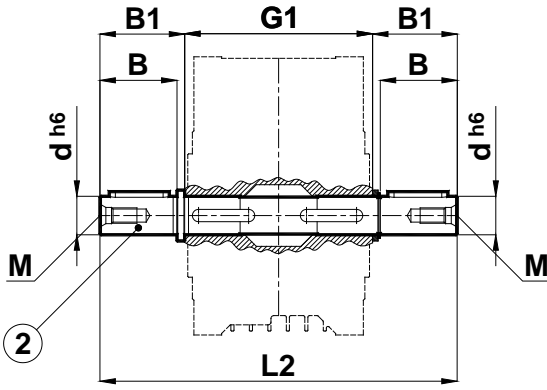

Ex.xxx.01

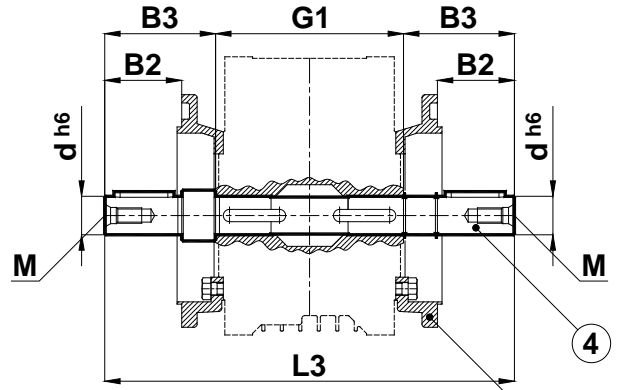

Ex.xxx.02

5

Tip Type Typ	Montaj Ölçüleri / Mounting Dimensions / Befestigungsmaße													Ağırlıklar / Weight / Gewicht				
	d	B	B1	B2	B3	G1	L	L1	L2	L3	M	b1	t1	1	2	3	4	5
E.030..	14	30	34	30	51.5	66	103	134	169	120.5	M5	5	16	0.18	0.20	0.35	0.27	0.15
E.040..	18	40	44.5	40	66	82	130	171	214	151.5	M6	6	20.5	0.35	0.30	0.55	0.40	0.20
E.050..	25	50	55	50	70.5	98	158	208	239	173	M10	8	28	0.70	0.50	0.90	0.60	0.30
E.063..	25	50	55	50	72	122	182	232	266	199	M10	8	28	1.10	0.90	1.40	1.00	0.40
E.075..	35	65	72	65	116	120	197	264	352	235	M12	10	38	2.10	1.50	3.15	1.90	0.70
E.080..	35	65	72	65	103.5	133	210	277	340	241.5	M12	10	38	2.25	1.60	3.0	2.00	0.90
E.100..	42	80	87	80	114	156	249	330	384	276	M16	12	43	5.10	3.90	6.50	4.50	3.65
E.125..	45	100	107.5	100	142	185	300	400	469	335	M16	14	48.5	8.70	6.50	10.60	7.40	6.80



# Ölçü Sayfaları

## Dimension Pages

### Abmessungsseiten

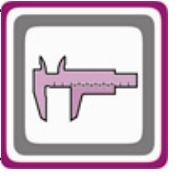

Moment Kolu / Torque Arm / Drehmomentstütze

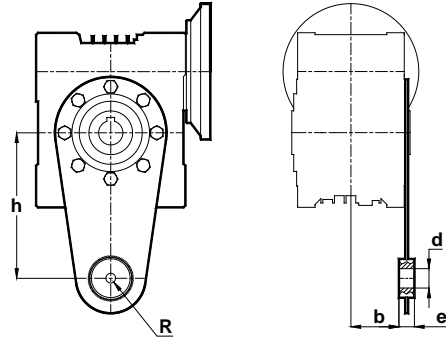

Tipi Type Typ	b	e	d	h	R	Parça No Part No Teil Nr
E.030..	22	14	10	85	25	9E030
E.040..	31	14	10	100	25	9E040
E.050..	38	16	10	100	32	9E050
E.063..	49.5	16	10	150	36	9E063
E.075..	49.5	25	20	200	45	9E075
E.080..	49.5	25	20	200	45	9E080
E.100..	57.5	30	25	250	50	9E100
E.125..	72	30	25	300	55	9E125

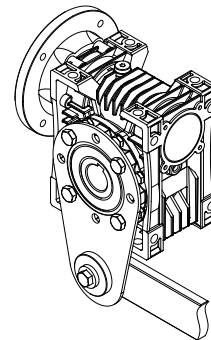
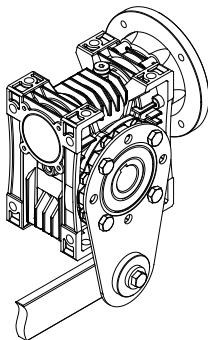
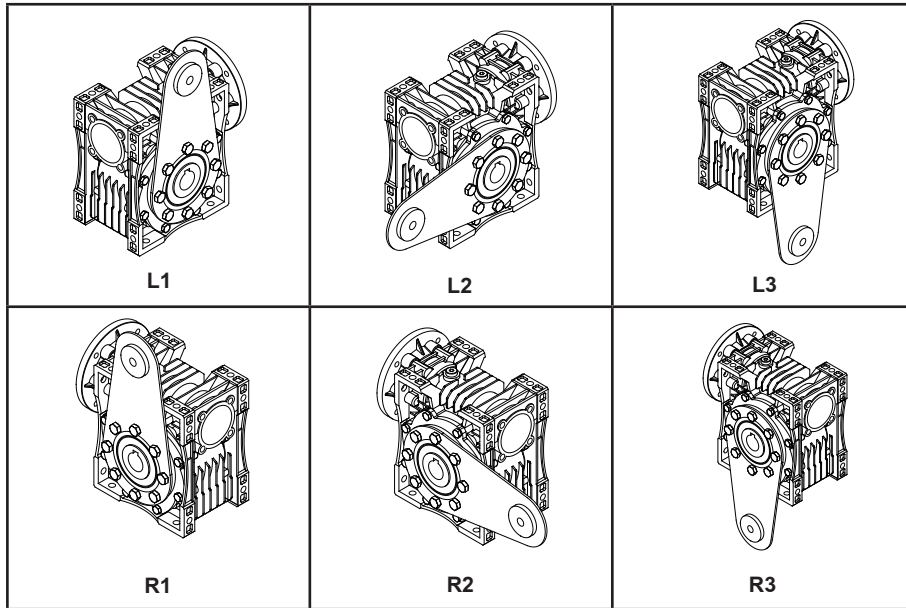





# Ölçü Sayfaları

## Dimension Pages

### Abmessungsseiten



Opsiyonel delik mil ölçüleri / Optional hollow shaft dimensions / Sonder-Hohlwellenmaßen

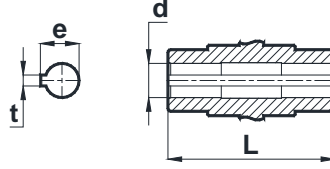

Tipi Type Typ	Mil Ölçüleri Shaft Dimensions Wellenmaße			
	d (H7)	e	t	L
EN030.X0	14	16.3	5	66
EN040.X0	14	16.3	5	82
	18(Std)	20.8	6	
	19	21.8	6	
EN050.X0	20	22.8	6	98
	18	20.8	6	
	19	21.8	6	
	20	22.8	6	
EN063.X0	24	27.3	8	122
	25(Std)	28.3	8	
	28	31.3	8	
	30	33.3	8	
	25	28.3	8	
EN075.X0	28	31.3	8	120
	30	33.3	8	
	32	35.3	10	
	35(Std)	38.3	10	
	25	28.3	8	
EN080.X0	28	31.3	8	133
	30	33.3	8	
	32	35.3	10	
	35(Std)	38.3	10	
	28	31.3	8	
EN100.X0	35	38.3	10	156
	38	41.3	10	
	40	43.3	12	
	42(Std)	45.3	12	
	45	48.8	14	
	50	53.8	14	
EN125.X0	30	33.3	8	185
	35	38.3	10	
	40	43.3	12	
	45(Std)	48.8	14	
	50	53.8	14	
	60	64.4	18	



# Ölçü Sayfaları Dimension Pages Abmessungsseiten

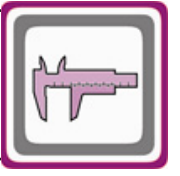

**Sonsuz Tip Redüktörlerde Tavsiye Edilen Mil Boyu Montaj-Demontaj Şekli Ve Aksesuarları**  
*Advised Shaft Dimension And Accesories Used By Assembling Worm Gear Type Gearboxes*  
*Empfohlene Wellenmaßen und Verbindungselemente bei Montage für Schneckengetriebe*

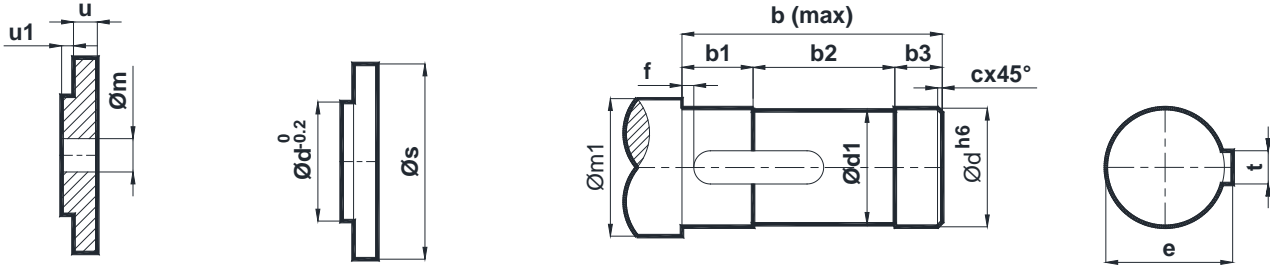

Part No: GN35.

Tip  
Type  
Typ

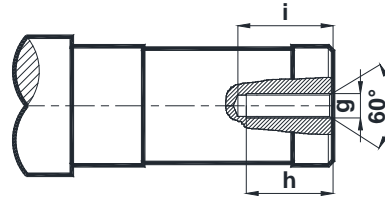

Örnek : GN35.E040

Tip Type Typ	s	m	u	u1	t	e	d	d1	b	b1	b2	b3	c	m1	f	h	i	g	y
E..030	18	6	3	2.5	5	16	14	13	63	24.5	17	21.5	0.5	19.5	5	14.5	17	M5	M5x20
E..040	24	6	3	2.5	6	20.5	18	17	79	20	42	17	1	24.5		14.5	17	M5	M6x25
E..050	34	11	5	3.5	8	28	25	24	93.5	28	42	23.5	1	33		24	30	M10	M10x30
E..063	34	11	5	3.5	8	28	25	24	117.5	36	50	31.5	1	33		24	30	M10	M10x30
E..075	44	13	6	3.5	10	38	35	34	115.5	43	34	38.5	1	42		30	37	M12	M12x40
E..080	44	13	6	3.5	10	38	35	34	128.5	46	41	41.5	1	42		30	37	M12	M12x40
E..100	54	17	6	3.5	12	45	42	41	151.5	52	52	47.5	1.5	49		38	45	M16	M16x45
E..125	54	17	8	3.5	14	48.5	45	44	180.5	66	53	61.5	2	54		38	45	M16	M16x45

Çektirme / Mounting / Befestigen

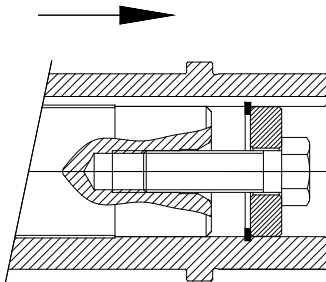

Sökme / Demounting / Einziehen

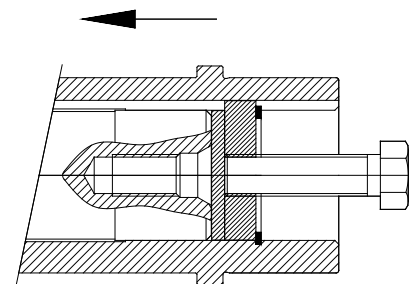

**6 Köşe Başlı Civata / 6 Contour Bolt / Sechskantschraube**  
(DIN ISO 4014 . DIN ISO 4017)  
(DIN ISO 8765)



# Ölçü Sayfaları

Dimension Pages  
Abmessungsseiten

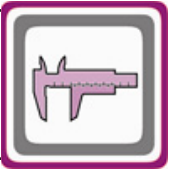

Mil Muhafaza Kapağı / Shaft Protection Cover / Wellenabdeckkappe

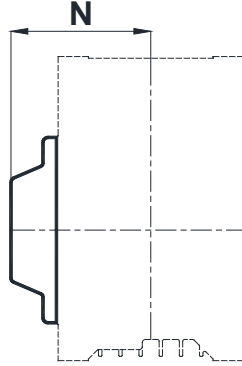

Tipi Type Typ	N
E.030	46.5
E.040	57.5
E.050	65.5
E.063	83
E.075	90
E.080	93
E.100	108
E.125	128.5



# Ölçü Sayfaları

## Dimension Pages

### Abmessungsseiten



Opsiyonel olarak yapılabilir flanş ölçüleri / Alternative flange dimensions / Sonderflanschmaßen

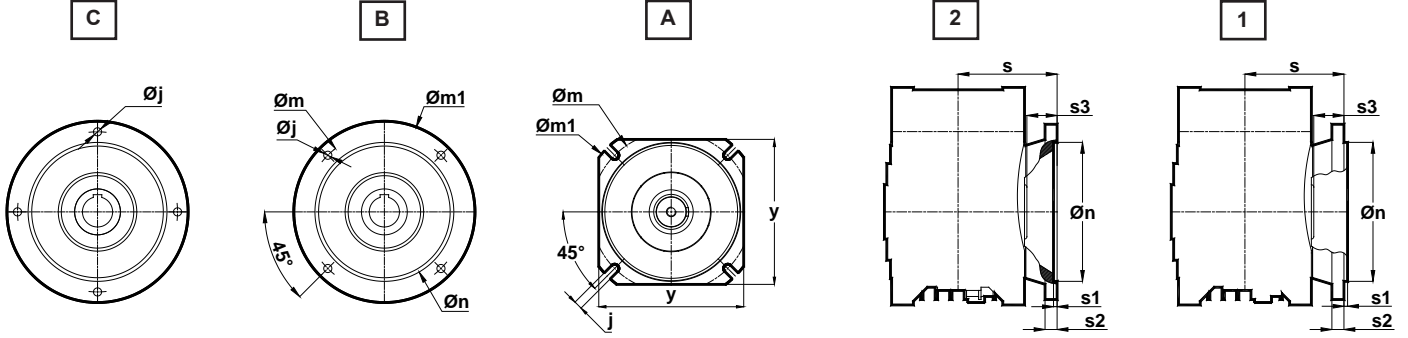

Tipi Type Typ	Stok Kodu Stock Code Produktnummer	Flanş Tipi Flangetype Flanschtyp	Montaj Ölçüleri Mounting Dimensions Befestigungsmaße								
			n	m	m1	j	s	s1	s2	s3	y
EX030	5E030X05	A2	50	68	80	6.5	54.5	4	8	21.5	70
	5E030X01	B1	70	85	105	7	55	2.5	6	22	-
	5E030X06	B1	70	85	105	7	81	2.5	6	48	-
	5E030X02	B1	80	100	120	7	55	2.5	6	22	-
EX040	5E040X11	A2	60	75	110	10	69.5	4	9.5	28.5	95
	5E040X12	A1	60	75	110	10	97	3.5	9.5	56	95
	5E040X10	B2	80	100	120	10	58.5	3	8	17.5	-
	5E040X04	C1	80	100	120	7	72.5	4	10	31.5	-
	5E040X05	C2	80	100	120	7	72.5	4	12	31.5	-
	5E040X02	B1	95	115	140	9	72.5	4	10	31.5	-
	5E040X06	B1	110	130	160	9	76	3.5	10	31.5	-
EX050	5E050X12	A2	70	85	125	10	91	5	9	42	110
	5E050X02	C1	95	115	140	9	74	3.5	10	25	-
	5E050X01	C1	95	115	140	9	91	3.5	10	42	-
	5E050X05	C2	95	115	140	9	90.5	3.5	10	41.5	-
	5E050X06	C2	95	115	140	9	74.5	3.5	10	25.5	-
	5E050X04	B1	95	130	160	9	74	3.5	10	25	-
	5E050X07	B2	95	130	160	9	90.5	3.5	10	41.5	-
	5E050X03	B1	95	130	160	9	91	3.5	10	42	-
	5E050X09	B1	110	130	160	9	93	3.5	15	44	-
	5E050X10	B2	110	130	160	9	93	5.5	15	44	-
	5E050X19	B1	110	130	160	11	105	3.5	12	56	-
	5E050X16	B1	110	130	160	9	119.5	3.5	15	70.5	-
	5E050X17	C1	130	165	200	11	119.5	3.5	15	70.5	-
EX063	5E063X13	B1	100	130	160	11	136	3.5	10	75	-
	5E063X07	B2	100	130	160	11	136	6	10	75	-
	5E063X02	B2	110	130	160	11	96	4	10	35	-
	5E063X06	B1	110	130	160	11	94	2	8	33	-
	5E063X12	A2	115	150	180	12	83	6	10	22	145
	5E063X11	B2	130	165	200	11	96	4	10	35	-
EX075	5E075-160	B2	110	130	160	11	90	6	13	30	-
	5E075X01	B1	110	130	160	12	111	3.5	13	51	-
EX080	5E080X07	B1	130	165	200	11	107	3	12	40	-
	5E080X05	A2	130	165	200	14	118	6	13	51.5	170
EX100	5E100X04	A2	152	175	210	14	119	6	13	41	200
	5E100X05	A2	170	230	280	14	131	6	15	53	260
EX125	5E125X05	A2	170	230	280	14	146	6	15	53.5	260

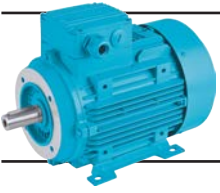

# **Elektrik Motorlarının Performans Deęerleri**

*Electric Motors  
Ratings and Performance*

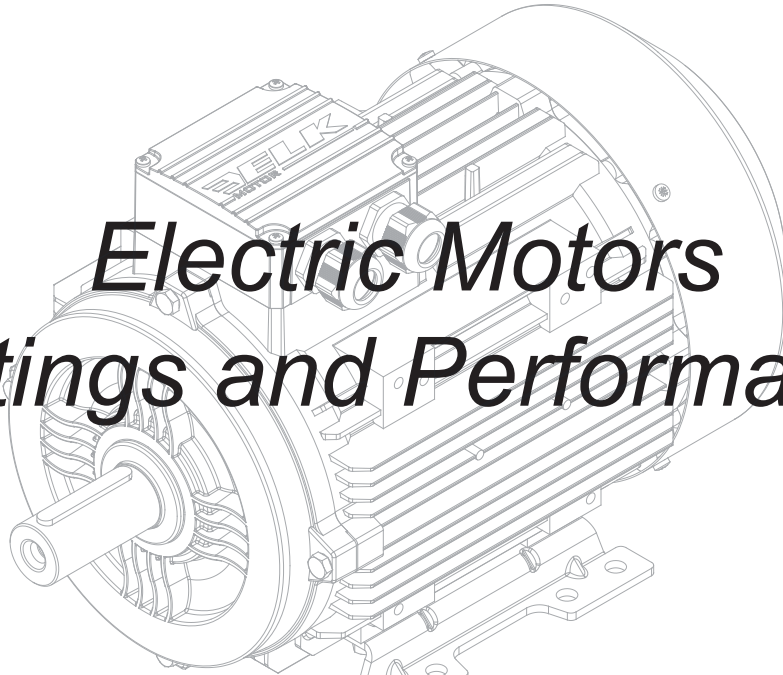

**Elektromotoren  
Leistungsdaten**

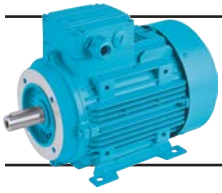

# Elektrik Motorlarının Performans Değerleri

## Electric Motors Ratings and Performance

### Elektromotoren Leistungsdaten



400V 50Hz 3000 d/d / 400V 50Hz 3000 rpm / 400V 50Hz 3000 UpM

IE3

Tip Type Typ	Tam Yük Değerleri Full-load Data Vollastdaten								Kalkış Değerleri Starting Data Startdaten		Devrilme Momenti Breakdown Torque Kippmoment	Atalet Momenti Moment of Inertia Trägheitsmoment	B3 Motor Ağırlığı B3 Motor Weight B3 Motor Gewicht	Ses Seviyesi Noise Level Geräuschpegel
	Güç Power Leistung	Devir Speed Drehzahl	Akım Current Nennstrom	Moment Torque Drehmoment	Güç Faktörü Power Factor Leistungsfaktor	Verim % $\eta$ Efficiency % $\eta$ Wirkungsgrad % $\eta$			Akım Current Nennstrom	Moment Torque Drehmoment				
	kW	d/d rpm UpM	A	Nm	cos $\phi$	4 / 4	3 / 4	1 / 2	$I_A/I_N$	$M_A/M_N$				
3E71M/2B	0,37	2830	0,86	1,25	0,81	76,6	77,0	75,0	6,0	2,8	3,0	0,00086	6,2	53
3E71M/2C	0,55	2830	1,19	1,86	0,84	79,4	80,2	78,8	6,1	2,9	3,3	0,00096	7,2	53
3E80M/2B	0,75	2880	1,59	2,49	0,84	80,7	82,0	81,5	6,7	3,0	3,6	0,00140	9,6	54
3E80M/2C	1,1	2880	2,26	3,64	0,85	82,7	83,0	82,4	6,8	3,1	3,8	0,00165	10,9	54
3E90S/2B	1,5	2900	2,97	4,94	0,86	84,8	85,4	84,2	7,6	3,1	3,9	0,00220	15,6	59
3E90L/2C	2,2	2900	4,25	7,24	0,87	85,9	86,8	86,1	7,2	3,0	3,8	0,00310	17,0	59
3E100L/2C	3	2915	5,58	9,83	0,89	87,1	87,6	86,9	7,9	3,0	4,1	0,00540	23,3	62
3E112M/2C	4	2915	7,28	13,1	0,90	88,1	88,8	88,2	7,5	2,6	3,9	0,01100	29,1	65
3E132S/2B	5,5	2945	9,9	17,83	0,90	89,2	89,0	88,6	8,9	2,9	3,9	0,02200	44,4	67
3E132S/2C	7,5	2945	13,2	24,32	0,91	90,1	90,5	89,7	8,4	2,6	4,0	0,02900	51,5	67
3E160M/2A	11	2955	19,5	35,5	0,89	91,2	91,2	90,4	8,5	3,1	4,0	0,03400	105	70
3E160M/2B	15	2955	27	48,5	0,87	91,9	91,8	91,6	7,5	2,4	3,0	0,04600	120	70
3E160L/2	18,5	2960	31,5	59,9	0,92	92,4	92,5	92,0	8,2	3,0	3,2	0,05600	145	70
3E180M/2	22	2960	38	71	0,90	92,7	92,6	92,2	7,0	2,4	3,0	0,07500	170	70
3G200L/2a	30	2980	52	96	0,89	93,3	93,3	92,8	8,5	2,8	3,5	0,15000	240	73
3G200L/2b	37	2980	63	119	0,90	93,7	93,7	93,1	8,3	2,8	3,1	0,17000	270	73
3G225M/2	45	2980	77	144	0,91	94,0	94,1	93,0	8,7	2,7	3,1	0,26000	380	73
3G250M/2	55	2985	92	176	0,92	94,3	94,5	93,3	8,7	2,9	3,0	0,47000	480	76
3G280S/2	75	2985	127	240	0,90	94,7	94,6	94,0	8,0	2,9	3,2	0,62000	585	76
3G280M/2	90	2985	148	288	0,92	95,0	95,0	93,7	8,2	2,9	3,0	0,74000	645	76
3G315S/2	110	2985	186	353	0,90	95,2	95,2	94,0	8,0	2,5	3,0	1,20000	742	76
3G315M/2a	132	2985	223	423	0,90	95,4	95,4	94,1	8,0	2,4	3,5	1,40000	812	79
3G315M/2b	160	2985	265	513	0,91	95,6	95,6	94,2	8,0	2,5	3,0	1,50000	912	79

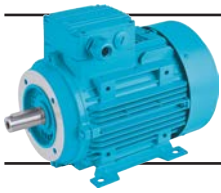

# Elektrik Motorlarının Performans Değerleri

## Electric Motors Ratings and Performance

### Elektromotoren Leistungsdaten



400V 50Hz 1500 d/d / 400V 50Hz 1500 rpm / 400V 50Hz 1500 UpM

IE3

Tip Type Typ	Tam Yük Değerleri Full-load Data Vollastdaten							Kalkış Değerleri Starting Data Startdaten			Devrilme Momenti Breakdown Torque Kippmo- ment	Atalet Momenti Moment of Inertia Trägheits- moment	B3 Motor Ağırlığı B3 Motor Weight B3 Motor Gewicht	Ses Seviyesi Noise Level Geräusch- pegel
	Güç	Devir	Akım	Moment	Güç Faktörü	Verim % $\eta$			Akım	Moment				
	Power	Speed	Current	Torque	Power Factor	Efficiency % $\eta$			Current	Torque				
	Leistung	Drehzahl	Nennstrom	Drehmoment	Leistungsfaktor	Wirkungsgrad % $\eta$			Nennstrom	Drehmoment				
	kW	d/d rpm UpM	A	Nm	cos $\phi$	4 / 4	3 / 4	1 / 2	$I_A/I_N$	$M_A/M_N$	$M_K/M_N$	kgm <sup>2</sup>	kg	dB(A)
3E71M/4C	0,25	1435	0,67	1,66	0,71	76,0	75,4	71,5	5,4	2,2	3,0	0,00096	6,8	45
3E71M/4D	0,37	1435	0,97	2,46	0,70	78,5	78,2	75,0	5,5	2,2	3,1	0,00120	7,5	45
3E80M/4C	0,55	1450	1,34	3,62	0,73	80,8	80,4	77,0	5,9	2,1	3,1	0,00220	10,5	50
3E80M/4D	0,75	1450	1,77	4,94	0,74	82,5	82,3	80,0	6,2	2,5	3,4	0,00360	11,6	50
3E90S/4C	1,1	1450	2,46	7,25	0,76	84,5	84,3	82,0	7,0	2,6	3,6	0,00420	16,3	51
3E90L/4D	1,5	1450	3,3	9,88	0,77	85,3	85,2	83,0	7,2	2,8	3,8	0,00480	18,0	51
3E100L/4C	2,2	1450	4,65	14,49	0,79	86,7	87,2	86,0	7,2	2,8	3,6	0,01100	24,4	53
3E100L/4D	3	1450	6,26	19,76	0,79	87,7	88,0	87,0	7,2	2,8	3,6	0,01300	26,7	53
3E112M/4D	4	1460	8,05	26,16	0,81	88,6	88,4	87,5	7,4	2,8	3,8	0,01500	33,9	58
3E132S/4C	5,5	1460	10,65	36	0,83	89,6	90,2	90,0	7,4	2,8	3,4	0,03500	53,4	61
3E132M/4D	7,5	1465	14,4	48,9	0,83	90,4	90,4	89,4	7,9	3,0	3,8	0,04200	59,5	61
3E160M/4C	11	1470	21	71,5	0,83	91,4	91,3	91,0	6,9	2,4	3,1	0,07200	120	63
3E160L/4D	15	1470	29	97,4	0,81	92,1	92,0	91,8	6,9	2,5	3,2	0,09200	144	63
3E180M/4	18,5	1475	34,5	120	0,84	92,6	92,6	91,6	7,8	3,2	3,8	0,15000	180	64
3E180L/4	22	1475	42,5	142	0,80	93,0	92,8	92,0	8,3	3,5	4,0	0,17000	190	64
3G200L/4	30	1475	55	194	0,84	93,6	93,5	93,3	7,9	2,8	3,7	0,25000	240	64
3G225S/4	37	1475	67	240	0,85	93,9	93,9	93,5	7,5	3,1	3,3	0,36000	330	64
3G225M/4	45	1475	80	291	0,86	94,2	94,2	93,4	7,4	3,0	3,1	0,44000	360	64
3G250M/4	55	1480	96	355	0,87	94,6	94,7	94,0	7,7	3,2	3,0	0,78000	445	67
3G280S/4	75	1485	133	482	0,86	95,0	94,9	94,4	7,6	2,9	3,0	1,11000	605	67
3G280M/4	90	1485	158	579	0,86	95,2	95,2	94,8	7,4	2,9	3,0	1,32000	665	67
3G315S/4	110	1487	194	707	0,86	95,4	95,2	95,0	7,4	2,4	3,0	2,5000	861	74
3G315M/4a	132	1487	230	848	0,87	95,6	95,4	95,3	7,4	2,4	3,0	2,8000	882	74
3G315M/4b	160	1488	275	1027	0,88	95,8	95,6	95,6	6,9	2,2	2,9	3,0000	930	74

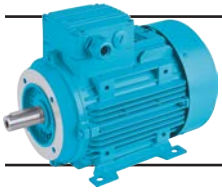

# Elektrik Motorlarının Performans Değerleri

## Electric Motors Ratings and Performance

### Elektromotoren Leistungsdaten



400V 50Hz 1000 d/d / 400V 50Hz 1000 rpm / 400V 50Hz 1000 UpM

IE3

Tip Type Typ	Tam Yük Değerleri Full-load Data Vollastdaten								Kalkış Değerleri Starting Data Startdaten		Devrilme Momenti Breakdown Torque Kippmo- ment	Atalet Momenti Moment of Inertia Trägheits- moment	B3 Motor Ağırlığı B3 Motor Gewicht	Ses Seviyesi Noise Level Geräusch- pegel
	Güç Power Leistung	Devir Speed Drehzahl	Akım Current Nennstrom	Moment Torque Drehmoment	Güç Faktörü Power Factor Leistungsfaktor	Verim % $\eta$ Efficiency % $\eta$ Wirkungsgrad % $\eta$			Akım Current Nennstrom	Moment Torque Drehmoment				
	kW	d/d rpm UpM	A	Nm	cos $\phi$	4 / 4	3 / 4	1 / 2	$I_A/I_N$	$M_A/M_N$				
3E71M/6C	0,18	930	0,55	1,85	0,69	68,0	67,4	62,6	3,6	2,0	2,4	0,00092	6,7	41
3E71M/6D	0,25	930	0,77	2,57	0,67	70,0	69,7	66,0	3,6	2,2	2,5	0,00105	7,5	41
3E80M/6B	0,37	930	1,03	3,8	0,70	74,0	73,8	70,0	4,4	2,1	2,6	0,00240	9,8	43
3E80M/6C	0,55	935	1,47	5,62	0,70	77,2	77,3	74,4	4,3	2,2	2,7	0,00270	10,6	43
3E90S/6B	0,75	945	1,96	7,58	0,70	78,9	79,5	77,6	4,7	2,2	2,7	0,00400	14,6	46
3E90L/6C	1,1	940	2,75	11,2	0,71	81,0	80,8	79,4	5,0	2,2	2,7	0,00480	17,0	46
3E100L/6B	1,5	955	3,5	15	0,75	82,5	82,7	81,4	5,3	2,1	2,8	0,01400	22,5	50
3E112M/6B	2,2	965	4,95	21,7	0,76	84,3	84,5	83,5	5,5	2,2	3,0	0,01900	27,2	56
3E132S/6B	3	970	6,55	29,4	0,77	85,6	85,5	84,5	6,2	2,1	3,0	0,03400	46,5	58
3E132M/6C	4	970	8,52	39,4	0,78	86,8	87,0	85,5	6,2	2,2	3,0	0,03900	51,0	58
3E132M/6D	5,5	970	11,55	54,15	0,78	88,0	88,9	88,5	6,2	2,2	3,0	0,04200	56,0	58
3E160M/6	7,5	970	15	73,8	0,81	89,1	89,0	88,1	6,3	2,2	2,8	0,11000	126	62
3E160L/6	11	970	21,5	108,3	0,82	90,3	90,3	89,0	7,0	2,5	3,2	0,14000	146	62
3E180L/6	15	975	29	147	0,82	91,2	91,2	90,8	6,9	2,6	3,2	0,24000	209	62
3G200L/6a	18,5	975	36,5	181	0,80	91,7	91,6	91,3	7,0	2,6	3,2	0,26000	222	61
3G200L/6b	22	975	43	215	0,80	92,2	92,0	91,7	7,0	2,6	3,2	0,32000	245	61
3G225M/6	30	985	58	291	0,80	92,9	92,9	92,1	7,0	3,3	2,7	0,69000	325	62
3G250M/6	37	987	69	358	0,83	93,3	93,2	92,9	7,0	2,8	2,6	0,99000	440	64
3G280S/6	45	990	92	434	0,75	93,7	93,7	92,9	6,9	3,0	2,8	1,5000	553	65
3G280M/6	55	990	107	531	0,79	94,1	94,1	92,8	7,3	3,3	3,2	1,7000	578	65
3G315S/6	75	992	140	722	0,82	94,6	94,6	94,4	7,2	2,7	3,0	2,9000	805	72
3G315M/6a	90	992	166	866	0,83	94,9	94,9	94,5	7,2	2,7	3,0	3,5000	860	72
3G315M/6b	110	992	198	1058	0,84	95,1	95,1	94,9	7,2	2,7	3,0	4,2000	980	72
3G315L/6	132	992	235	1270	0,85	95,4	95,4	95,2	7,2	2,7	3,0	4,3000	1150	72
3G355M/6a	160	993	290	1538	0,83	95,6	95,6	95,0	7,0	2,4	3,2	6,8000	1185	72



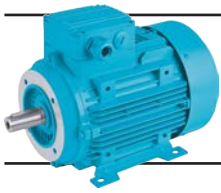

# Elektrik Motorlarının Performans Değerleri

## Electric Motors Ratings and Performance

### Elektromotoren Leistungsdaten



400V 50Hz 3000 d/d / 400V 50Hz 3000 rpm / 400V 50Hz 3000 UpM

IE2

Tip Type Typ	Tam Yük Değerleri Full-load Data Vollastdaten							Kalkış Değerleri Starting Data Startdaten			Devrilme Momenti Breakdown Torque Kippmoment $M_K/M_N$	Atalet Momenti Moment of Inertia Trägheitsmoment $\text{kgm}^2$	B3 Motor Ağırlığı B3 Motor Weight B3 Motor Gewicht kg	Ses Seviyesi Noise Level Geräuschpegel dB(A)
	Güç	Devir	Akım	Moment	Güç Faktörü	Verim % $\eta$			Akım	Moment				
	Power	Speed	Current	Torque	Power Factor	Efficiency % $\eta$			Current	Torque				
	Leistung	Drehzahl	Nennstrom	Drehmoment	Leistungsfaktor	Wirkungsgrad % $\eta$			Nennstrom	Drehmoment				
	kW	d/d rpm UpM	A	Nm	cos $\phi$	4 / 4	3 / 4	1 / 2	$I_A/I_N$	$M_A/M_N$				
G56/2b*	0,12	2800	0,35	0,41	0,74	64,5	64,1	56,9	4,2	2,5	2,8	0,00012	2,8	42
G63/2a*	0,18	2820	0,5	0,61	0,73	64,4	64,2	57,7	4,6	2,9	2,9	0,00011	3,6	52
G63/2b*	0,25	2840	0,67	0,84	0,63	67,3	67,1	60,9	4,5	2,5	2,9	0,00013	4,0	52
2E71M/2A	0,37	2805	0,9	1,26	0,80	74,2	74,5	72,5	5,0	2,5	2,8	0,00067	5,5	54
2E71M/2B	0,55	2800	1,25	1,87	0,84	75,8	77,0	76,0	5,0	2,4	2,7	0,00086	6,3	54
2E80M/2A	0,75	2850	1,67	2,51	0,83	78,0	79,0	77,5	5,7	2,5	3,0	0,00120	8,7	56
2E80M/2B	1,1	2850	2,36	3,69	0,84	80,1	81,3	80,7	5,8	2,7	3,1	0,00140	9,7	56
2E90S/2A	1,5	2880	3,19	4,98	0,83	81,8	82,6	82,0	6,0	2,4	3,1	0,00200	14,1	60
2E90L/2B	2,2	2860	4,48	7,35	0,85	83,2	85,0	85,0	6,0	2,6	3,1	0,00260	15,5	60
2E100L/2B	3	2900	5,8	9,88	0,88	84,8	85,2	84,7	7,0	2,6	3,4	0,00460	20,8	63
2E112M/2A	4	2910	7,5	13,13	0,89	86,5	87,1	86,8	7,0	2,4	3,6	0,00850	25,7	66
2E132S/2A	5,5	2930	10,2	17,93	0,89	87,4	87,8	87,0	7,5	2,4	3,7	0,01900	41	68
2E132S/2B	7,5	2925	13,6	24,5	0,90	88,5	88,8	88,6	7,6	2,6	3,7	0,02200	45,2	68
2E160M/2A	11	2945	19,5	35,7	0,91	89,5	89,5	88,6	8,5	3,4	3,6	0,03400	105	70
2E160M/2B	15	2945	28,3	48,6	0,85	90,4	90,4	89,7	7,5	3,0	3,5	0,04100	113	70
2E160L/2	18,5	2950	32,3	59,9	0,91	90,9	90,8	90,1	8,2	3,0	3,2	0,05100	135	70
2E180M/2	22	2960	38,3	71	0,91	91,3	91,3	90,8	8,2	3,0	3,5	0,07500	170	70
2G200L/2a	30	2970	52	96	0,91	92,0	92,0	91,2	8,3	2,7	3,0	0,13000	210	73
2G200L/2b	37	2970	65	119	0,89	92,6	92,6	91,7	8,3	2,7	3,0	0,15000	240	73
2G225M/2	45	2975	77	144	0,91	92,9	93,0	91,8	8,7	2,7	3,1	0,23000	343	73
2G250M/2	55	2980	94	176	0,91	93,2	93,7	92,2	8,7	2,9	3,0	0,41000	445	76
2G280S/2	75	2980	127	240	0,91	93,9	94,1	92,5	8,0	2,9	3,2	0,62000	585	76
2G280M/2	90	2980	151	288	0,91	94,2	94,2	92,7	8,5	2,7	3,0	0,74000	645	76
2G315S/2	110	2980	186	353	0,91	94,3	94,3	92,8	8,0	2,5	3,0	1,20000	742	79
2G315M/2a	132	2980	223	423	0,90	94,6	94,5	92,9	8,0	2,5	3,0	1,40000	812	79
2G315M/2b	160	2980	266	513	0,92	94,8	94,8	93,4	8,0	2,5	3,0	1,50000	912	79

\* : IE1 Verisi / IE1 Data / IE1 Daten

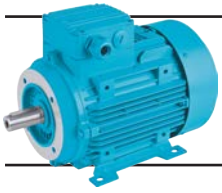

# Elektrik Motorlarının Performans Değerleri

## Electric Motors Ratings and Performance

### Elektromotoren Leistungsdaten



400V 50Hz 1500 d/d / 400V 50Hz 1500 rpm / 400V 50Hz 1500 UpM

IE2

Tip Type Typ	Tam Yük Değerleri Full-load Data Vollastdaten								Kalkış Değerleri Starting Data Startdaten		Devrilme Momenti Breakdown Torque Kippmoment	Atalet Momenti Moment of Inertia Trägheitsmoment	B3 Motor Ağırlığı B3 Motor Weight B3 Motor Gewicht	Ses Seviyesi Noise Level Geräuschpegel
	Güç Power Leistung	Devir Speed Drehzahl	Akım Current Nennstrom	Moment Torque Drehmoment	Güç Faktörü Power Factor Leistungsfaktor	Verim % $\eta$ Efficiency % $\eta$ Wirkungsgrad % $\eta$			Akım Current Nennstrom	Moment Torque Drehmoment				
	kW	d/d rpm UpM	A	Nm	cos $\phi$	4 / 4	3 / 4	1 / 2	$I_A/I_N$	$M_A/M_N$				
G63/4a*	0,12	1365	0,41	0,84	0,74	57,1	57,1	53,3	3,1	2,0	2,2	0,00017	3,4	43
G63/4b*	0,18	1340	0,6	1,28	0,73	59,7	59,7	55,8	2,9	2,0	2,0	0,00021	3,9	43
2E71M/4B	0,25	1425	0,71	1,68	0,69	74,0	73,5	70,5	4,4	2,0	3,0	0,00080	5,9	46
2E71M/4C	0,37	1425	1,0	2,47	0,70	76,1	75,5	71,5	4,6	2,0	3,0	0,00096	6,7	46
2E80M/4B	0,55	1440	1,45	3,65	0,71	77,1	76,7	75,0	5,2	2,0	3,0	0,00180	9,7	50
2E80M/4C	0,75	1440	1,89	4,97	0,72	79,6	79,2	77,0	5,2	2,0	3,0	0,00220	10,5	50
2E90S/4B	1,1	1440	2,6	7,3	0,75	81,4	81,4	80,5	5,6	2,2	3,1	0,00290	14,4	52
2E90L/4C	1,5	1440	3,4	9,95	0,77	82,8	83,0	82,0	6,0	2,3	3,2	0,00360	17,2	52
2E100L/4B	2,2	1445	4,85	14,6	0,78	84,3	85,3	84,2	6,0	2,1	3,2	0,00800	22,7	54
2E100L/4C	3	1440	6,42	19,89	0,79	85,5	85,7	84,6	6,3	2,3	3,1	0,01100	24,2	54
2E112M/4C	4	1450	8,2	26,35	0,81	86,8	87,4	86,5	6,6	2,5	3,4	0,01300	32	58
2E132S/4B	5,5	1455	11,05	36,1	0,82	87,7	88,6	88,0	6,7	2,6	3,2	0,03000	47,8	62
2E132M/4C	7,5	1460	15	49	0,81	88,7	89,0	89,0	7,0	2,7	3,3	0,03500	54,8	62
2E160M/4B	11	1470	21	71,5	0,84	90,0	90,1	89,3	6,9	2,8	3,1	0,07200	130	63
2E160L/4C	15	1470	29,3	97,4	0,82	90,6	90,7	89,7	7,5	2,6	3,5	0,09200	141	63
2E180M/4	18,5	1475	34,5	120	0,85	91,3	91,4	90,4	7,7	3,2	3,4	0,15000	180	64
2E180L/4	22	1475	42,5	142	0,82	91,7	91,7	90,6	8,3	3,7	3,8	0,17000	190	64
2G200L/4	30	1475	55	194	0,85	92,5	92,6	92,1	8,0	3,1	3,6	0,23000	227	64
2G225S/4	37	1475	67	240	0,86	92,7	92,7	92,2	7,2	3,0	3,0	0,35000	314	64
2G225M/4	45	1475	80	291	0,87	93,3	93,3	92,4	7,3	3,0	3,0	0,44000	360	64
2G250M/4	55	1480	96	355	0,88	93,7	93,8	93,2	7,6	3,1	2,9	0,78000	445	67
2G280S/4	75	1485	133	482	0,87	94,0	94,1	93,4	7,9	2,6	2,8	1,11000	605	67
2G280M/4	90	1485	158	579	0,87	94,3	94,5	93,8	7,4	2,9	3,0	1,32000	665	67
2G315S/4	110	1485	195	707	0,86	94,5	94,5	93,8	7,0	2,3	2,6	2,10000	784	74
2G315M/4a	132	1485	235	849	0,86	94,7	94,5	93,8	7,0	2,3	2,6	2,50000	861	74
2G315M/4b	160	1485	280	1029	0,87	95,0	94,9	94,0	7,0	2,3	2,6	2,70000	882	74

\* : IE1 Verisi / IE1 Data / IE1 Daten

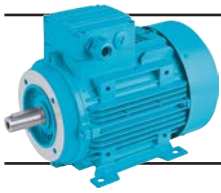

# Elektrik Motorlarının Performans Değerleri

## Electric Motors Ratings and Performance

### Elektromotoren Leistungsdaten



400V 50Hz 1000 d/d / 400V 50Hz 1000 rpm / 400V 50Hz 1000 UpM

IE2

Tip Type Typ	Tam Yük Değerleri Full-load Data Vollastdaten							Kalkış Değerleri Starting Data Startdaten			Devrilme Momenti Breakdown Torque Kippmo- ment $M_K/M_N$	Atalet Momenti Moment of Inertia Trägheits- moment $\text{kgm}^2$	B3 Motor Ağırlığı B3 Motor Weight B3 Motor Gewicht kg	Ses Seviyesi Noise Level Geräusch- pegel dB(A)
	Güç	Devir	Akım	Moment	Güç Faktörü	Verim % $\eta$			Akım	Moment				
	Power	Speed	Current	Torque	Power Factor	Efficiency % $\eta$			Current	Torque				
	Leistung	Drehzahl	Nennstrom	Drehmoment	Leistungsfaktor	Wirkungsgrad % $\eta$			Nennstrom	Drehmoment				
	kW	d/d rpm UpM	A	Nm	cos $\phi$	4 / 4	3 / 4	1 / 2	$I_A/I_N$	$M_A/M_N$				
2E71M/6B	0,18	920	0,6	1,87	0,67	64,5	63,0	57,0	3,2	1,9	2,3	0,00075	5,9	42
2E71M/6C	0,25	920	0,78	2,59	0,69	66,5	66,0	61,0	3,3	1,9	2,3	0,00092	6,6	42
2E80M/6A	0,37	925	1,08	3,82	0,69	71,4	71,5	70,0	4,0	2,0	2,6	0,00190	9,1	45
2E80M/6B	0,55	932	1,5	5,64	0,72	73,5	74,0	71,0	4,2	2,1	2,6	0,00240	9,9	45
2E90S/6A	0,75	940	2,0	7,62	0,71	75,9	76,1	73,1	4,1	2,0	2,6	0,00360	13,3	48
2E90L/6B	1,1	940	2,9	11,18	0,70	78,1	78,3	75,0	4,3	2,1	2,6	0,00400	14,8	48
2E100L/6A	1,5	950	3,72	15	0,73	79,8	80,2	79,5	4,5	2,1	2,6	0,01000	20,2	52
2E112M/6A	2,2	960	5,32	21,9	0,73	81,8	82,0	81,5	5,3	2,1	2,7	0,01400	25	56
2E132S/6A	3	970	6,85	29,6	0,76	83,3	84,0	83,0	5,6	2,0	2,8	0,02800	42	60
2E132M/6B	4	970	8,8	39,38	0,77	85,2	85,7	85,3	5,2	2,1	2,6	0,03400	46	60
2E132M/6C	5,5	965	12	54,4	0,77	86,0	87,2	87,0	5,7	2,1	2,7	0,03900	51	60
2E160M/6	7,5	960	15	74,6	0,83	87,2	87,2	84,5	6,5	2,5	3,0	0,11000	126	62
2E160L/6	11	965	22	108,9	0,81	88,7	88,7	85,7	6,5	2,5	3,0	0,14000	146	62
2E180L/6	15	965	29	148	0,83	89,7	89,7	86,8	6,5	2,4	3,0	0,20000	189	62
2G200L/6a	18,5	975	36,5	181	0,81	90,4	90,4	87,7	7,0	2,5	3,0	0,26000	222	61
2G200L/6b	22	975	43	215	0,81	91,1	91,1	88,4	7,0	2,5	3,0	0,32000	245	61
2G225M/6	30	980	58	292	0,81	91,7	91,7	89,6	7,0	3,0	2,6	0,69000	325	62
2G250M/6	37	985	69	359	0,84	92,2	92,2	90,1	7,0	3,0	2,6	0,99000	440	64
2G280S/6	45	990	92	434	0,76	92,7	92,7	90,9	7,0	3,3	2,6	1,50000	553	65
2G280M/6	55	990	107	531	0,80	93,1	93,1	91,5	7,0	3,3	2,6	1,60000	578	65
2G315S/6	75	990	140	723	0,82	93,7	93,7	92,4	7,0	2,5	3,0	2,50000	727	72
2G315M/6a	90	990	166	868	0,83	94,0	94,0	92,6	7,0	2,5	3,0	3,10000	805	72
2G315M/6b	110	990	198	1061	0,85	94,3	94,3	92,7	7,0	2,5	3,0	3,20000	860	72
2G315L/6a	132	990	235	1273	0,86	94,6	94,6	93,0	7,0	2,5	3,0	3,50000	1020	72
2G315L/6b	160	990	290	1543	0,84	94,8	94,8	93,2	7,0	2,5	3,0	3,80000	1120	72

