

SEISA

CHAIN & DRIVES
COMPLETE POWER
TRANSMISSION

POWER > SPEED > TORQUE

GEAR COUPLINGS SERIES M



SEISA Gear, Ltd.

Affiliated company of Sumitomo Heavy Industries, Ltd.

SEISA Couplings offer

FULL LINE OF COUPLINGS

As the world's leading manufacturer of Couplings and gears, gear drives, SEISA offers full line of Couplings as standardized types based on the abundant experiences for over 80 years in the industry.



DC

DC Coupling

Lubrication-free, non-backlash, maintenance-free



GC

GC Coupling

Compact sized coupling with high torque transmitted capability developed from our original technology

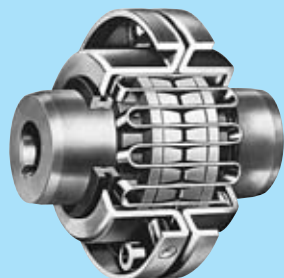

SF

SF Coupling

Grid-shaped spring to absorb shock load
(Under the licences from FALK corporation, USA)

SEISA Couplings have been applied to every industry around the world, enjoying high reputation on their reliability.

GC COUPLING CONTENTS

Application examples	02	Instruction for size selection and usage	10
Seisa Couplings Comparisons	03	Installation and maintenance	11
Features of GC Coupling	05	Recommended lubricants	11
Types and Construction of GC Coupling	06	Transmitted capacities and Dimensions	12~24
GC Coupling nomenclature and flexibility	07	Safety precautions	25
How to select	08	Gear Coupling Information Sheet	26

Application examples

GC Coupling

Roller table

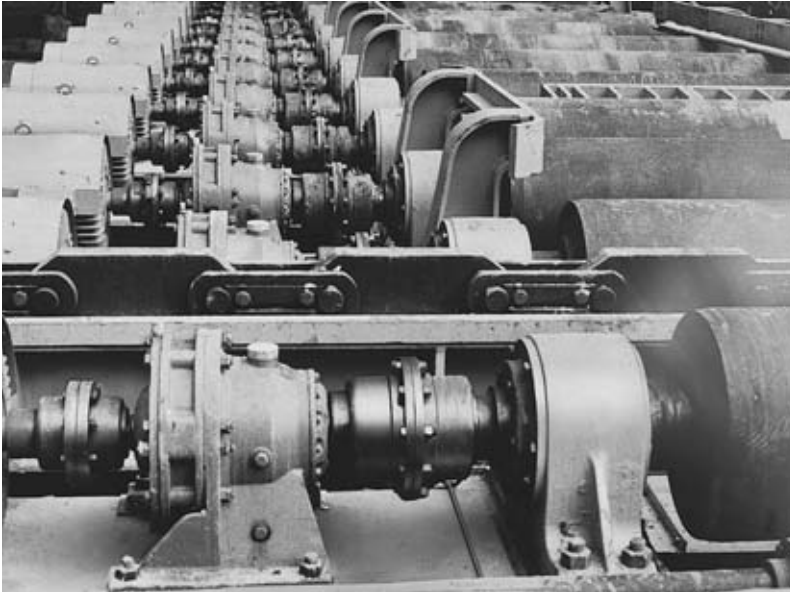

Heavy-duty crane

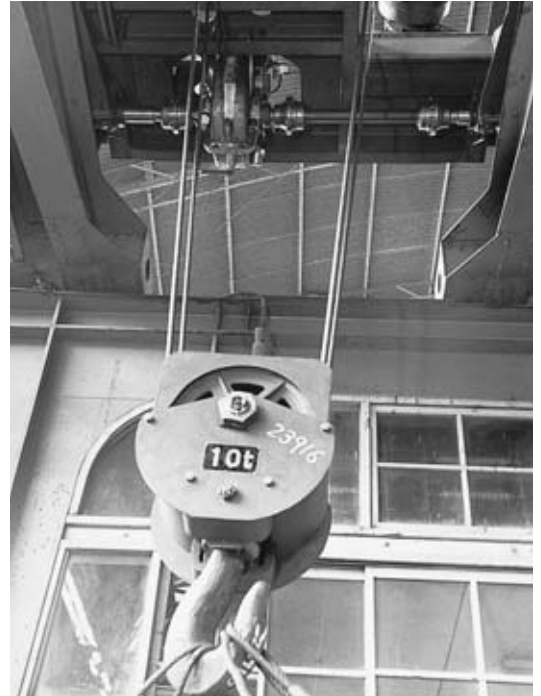

Rolling mill

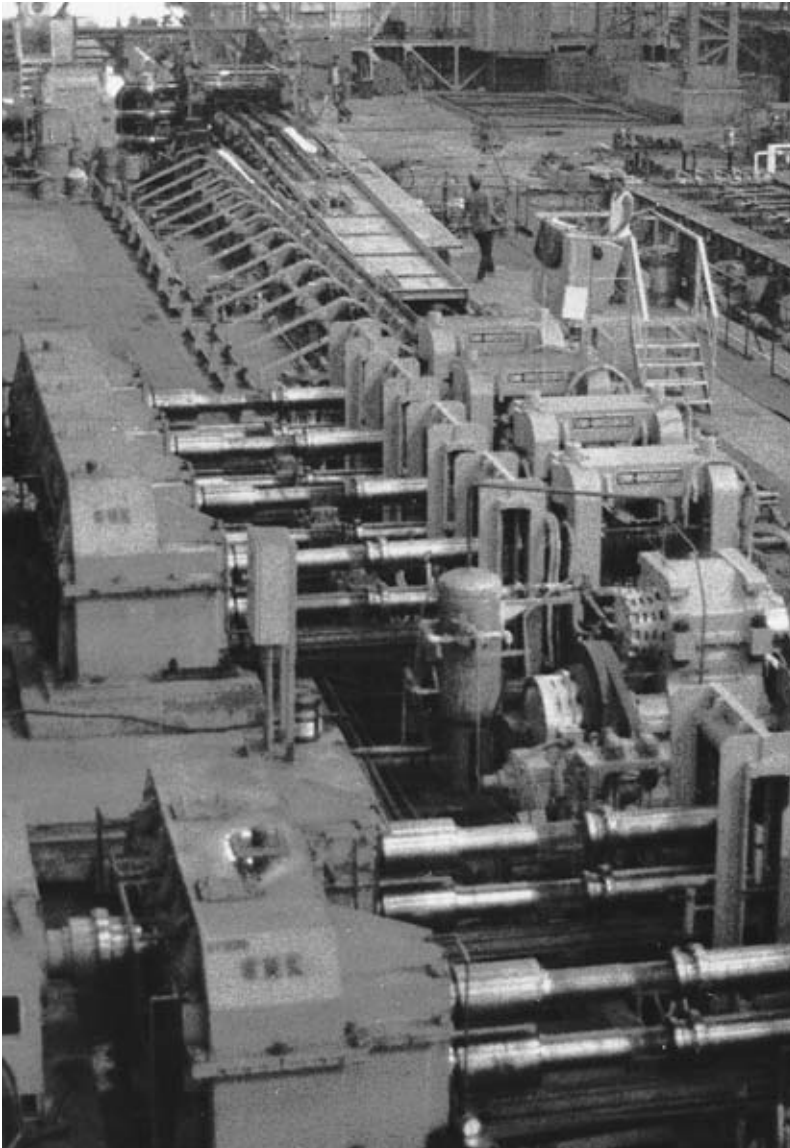

Pump

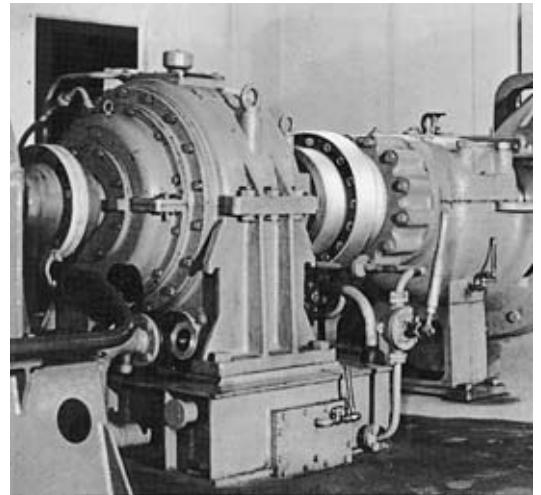

Paper mill

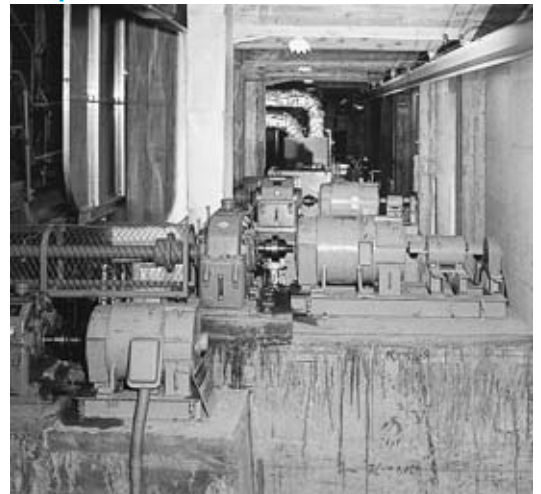

Seisa Coupling Comparisons

The features of DC, GC and SF Couplings are graphically presented here.

Select the Coupling optimum for your application.

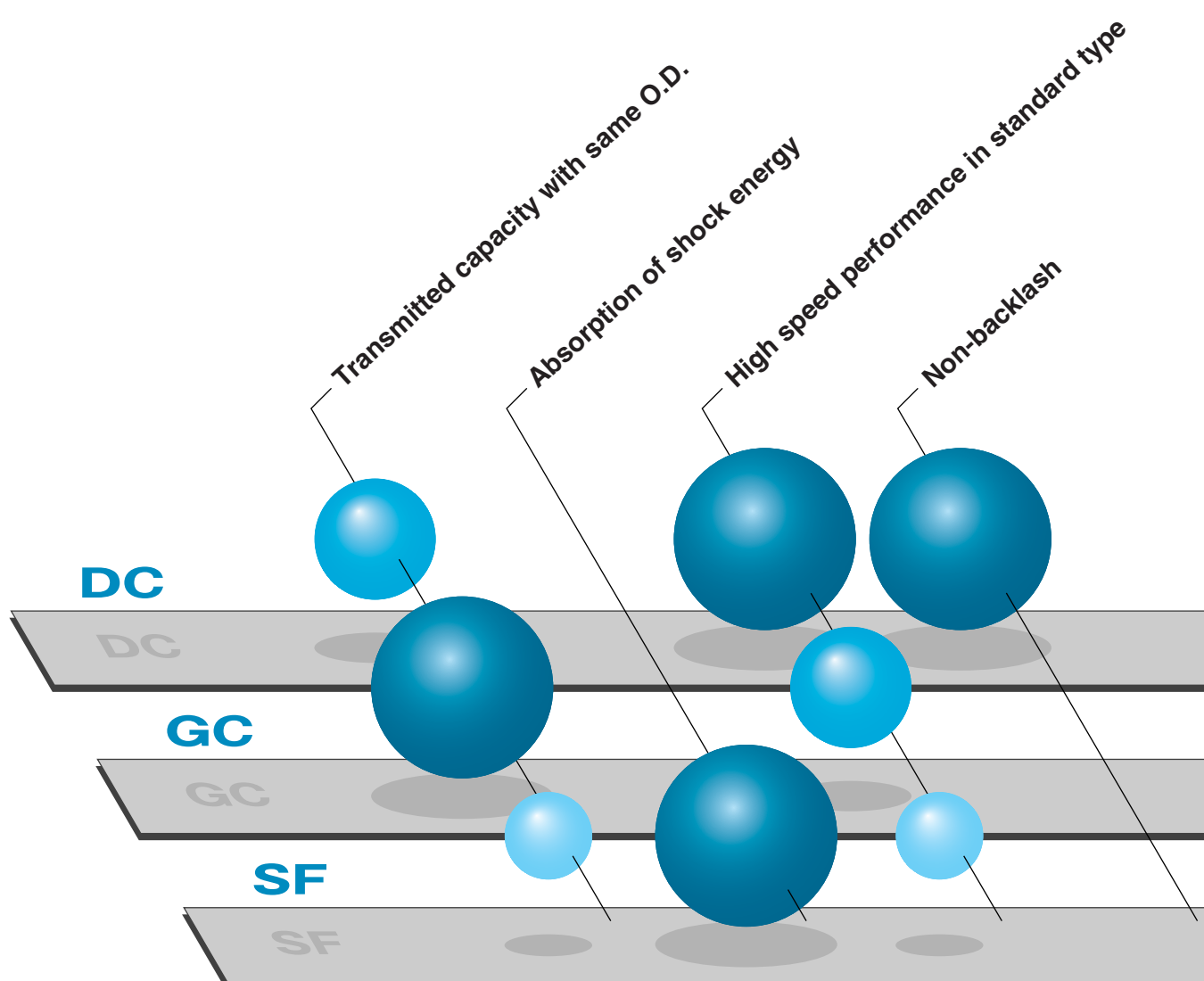

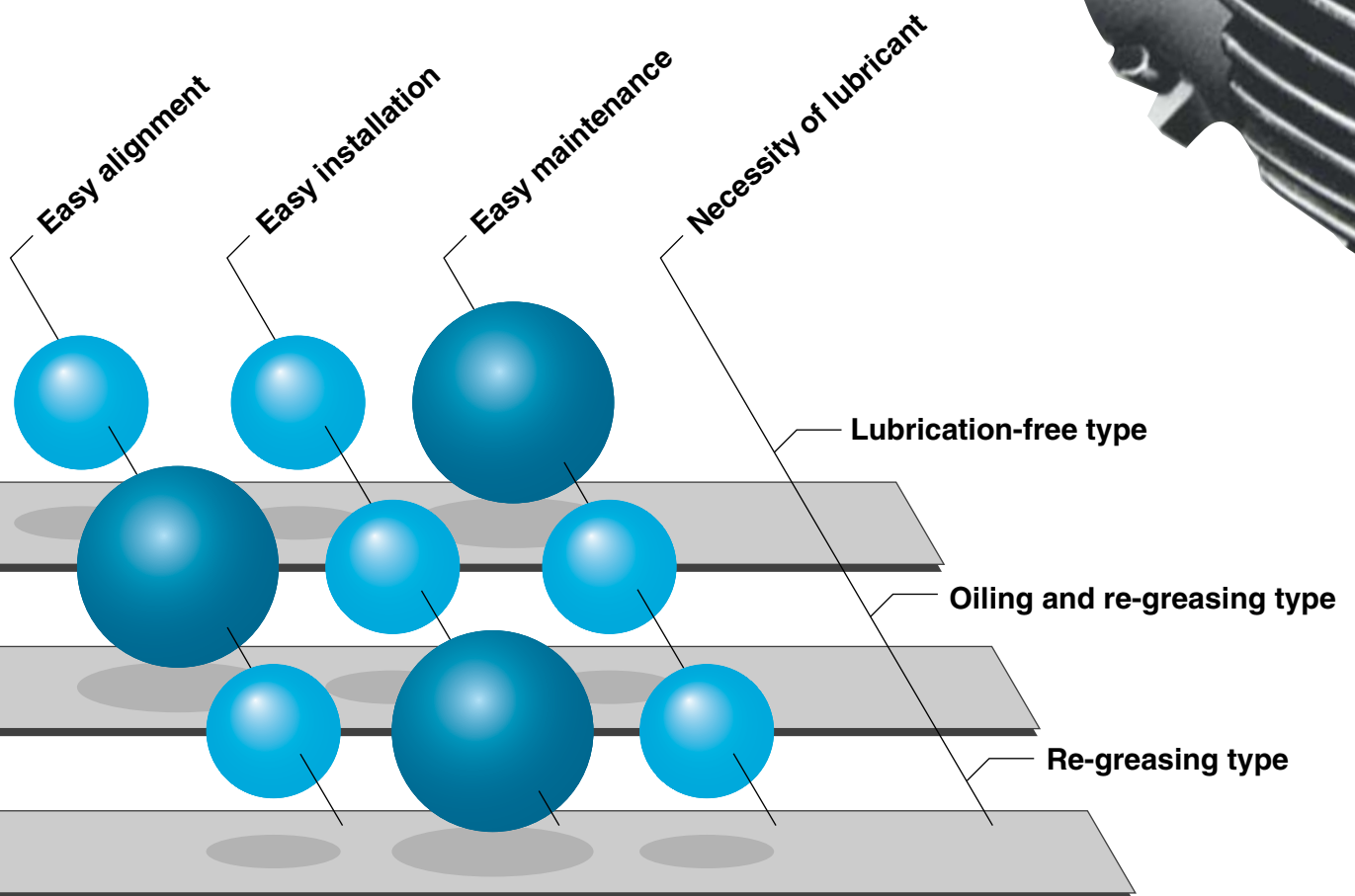
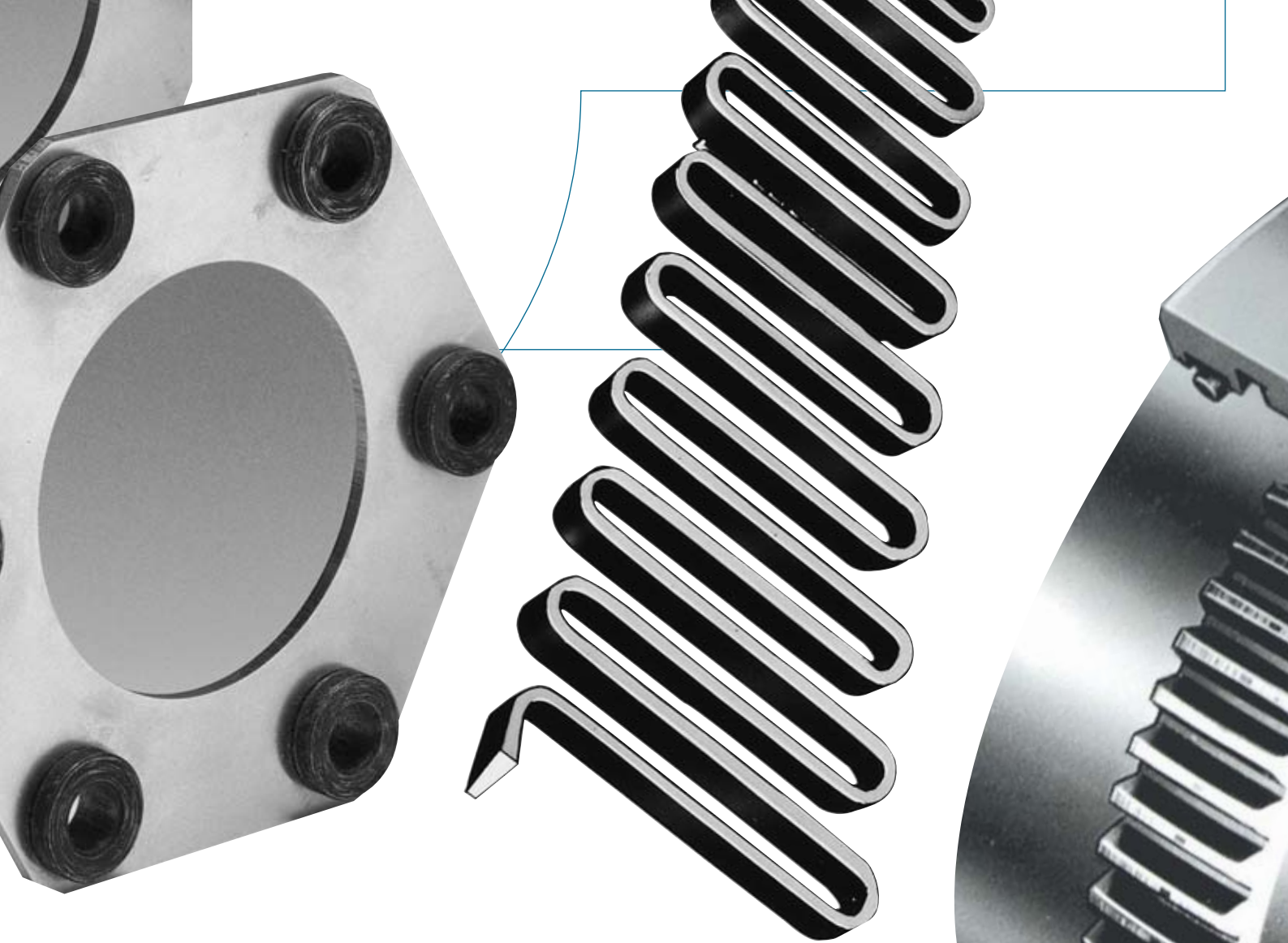

GC Coupling

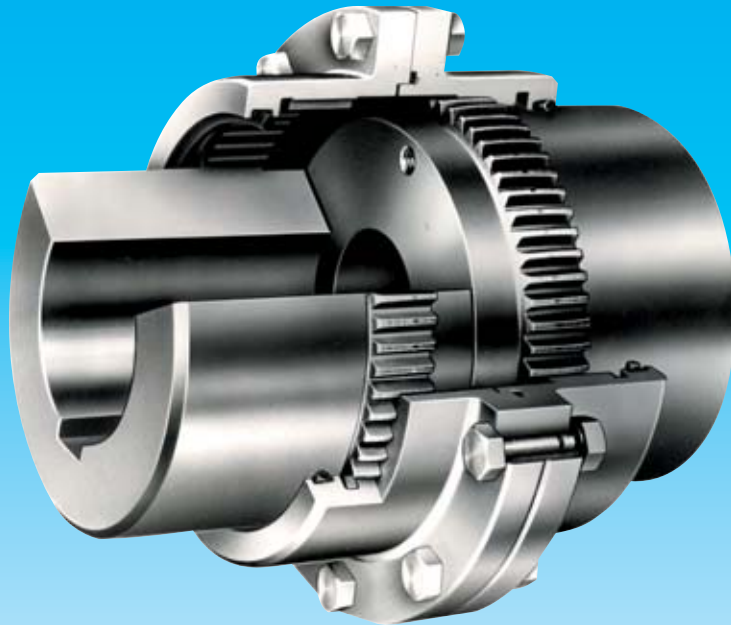

Features of GC Coupling

1. Prime mover torque is fully transmitted despite the presence of misalignment (offset and Angular) of shafts to a certain extent.
2. The Coupling automatically adjusts and absorbs parallel offset or tilting of the coupled shafts even if it occurs during operation, avoiding excessive loading on shaft and bearing and thus protecting the machine.
3. The flexible Coupling using crowned teeth features high durability and excellent wear resistant .
4. Separable Coupling center and case facilitates assembly and disassembly. Besides, compact lightweight design saves the space for installation.
5. Unlike other flexible Couplings, GC Coupling produces no difference of rotation angles between two shafts due to Coupling deflection, making it the optimum choice for line shaft Coupling, high speed and heavy duty applications.

Features of M series

1. The configurations are the same as the types SS, SE, CC and CE specified in JIS B1453 "Geared type shaft coupling". The catalog shows the four types adding prefix GC and suffix M to JIS expression, GC-SSM, GC-SEM, GC-CCM and GC-CEM, as well as GC-SMM, GC-SAM, GC-CAM, GC-SMV, GC-CMV and GC-EEM types.
2. The size number is indicated by the Coupling Case outside diameter. Bore diameter for shaft is in compliance with JIS, while Coupling O.D. is made more compact.
When compared with JIS Coupling, therefore, the product is more compact in size and lighter in weight, contributing to your cost savings.
3. As Coupling Center is longer relative to Coupling Case width, shafts can be easily aligned by moving the Coupling Case within the range of boss length. This configuration also makes the teeth inspection easier.
4. Upright type (GC-SMV, GC-CMV), spacer type (GC-SAM, GC-CAM) and coupling with the oil seal cover to prevent oil leakage from key way are standardized.
5. The types GC-MH are also standardized, whose power transmitted capacities are increased by heat treatment.

Types of GC coupling

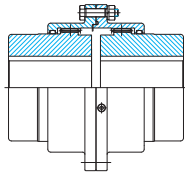

GC-SSM type
GC-SSMH type

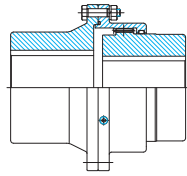

GC-SEM type
GC-SEMH type

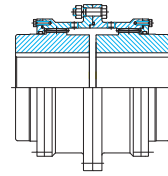

GC-CCM type
GC-CCMH type

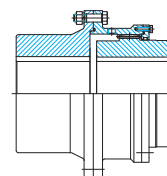

GC-CEM type
GC-CEMH type

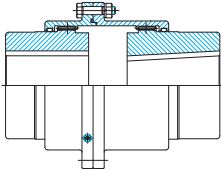

GC-SMM type

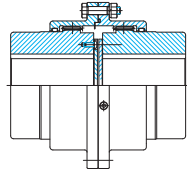

Equipped with
oil seal cover

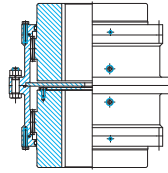

GC-CMV type
GC-CMVH type

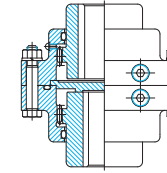

GC-SMV type
GC-SMVH type

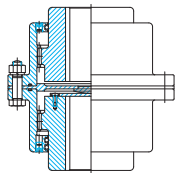

GC-SV type

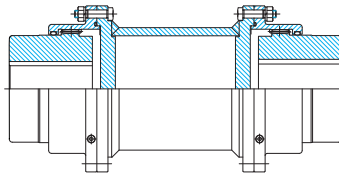

GC-SAM type
GC-CAM type

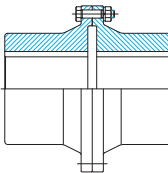

GC-EEM type

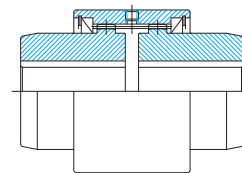

GC-GL type

Construction of GC coupling

1. Construction

GC coupling is constructed by the mesh between internal spur gear of the Coupling Case and crowned external spur gear of the Coupling Center. Working surface, top and bottom land of involute profile teeth are designed with crowns on all working portions of the teeth, so they can slide freely, and ensure uniform speed and smooth power transmission.

Having two gear meshes, GC-SSM and GC-CCM can always keep the case in the neutral position and transmit power smoothly despite offset alignment, Angular misalignment and axial gap. Having single gear mesh, GC-SEM and GC-CEM can accommodate angular misalignment and axial gap. As shown in Figure 5, normally two units should be applied in combination using an floating shaft.

2. Major parts and their materials

GC-SSM type

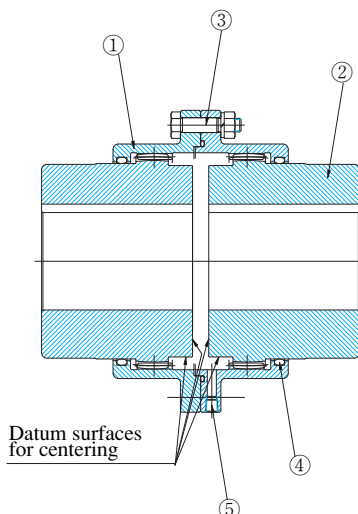
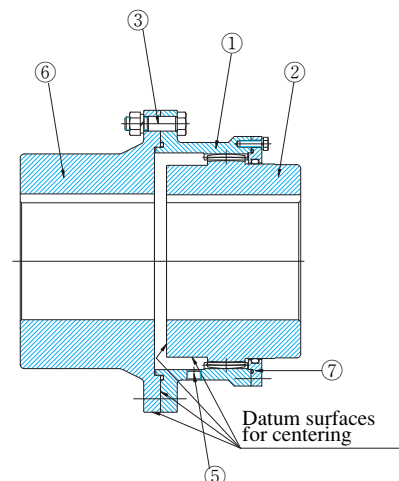

Table 1

GC-SSM, SEM types	Part name	GC-CCM, CEM types
① S45C	Coupling Case	S45C or SCMn2
② S45C	Coupling Center	S45C or SCMn2
③ SCM440	Reamer bolt	SCM440
④ Nitrile rubber	O-ring	Nitrile rubber
⑤ SCM435	Oil plug	SCM435
⑥ S45C	Rigid	S45C or SC46
⑦	Side cover	SS400

GC-CEM type



GC Coupling nomenclature

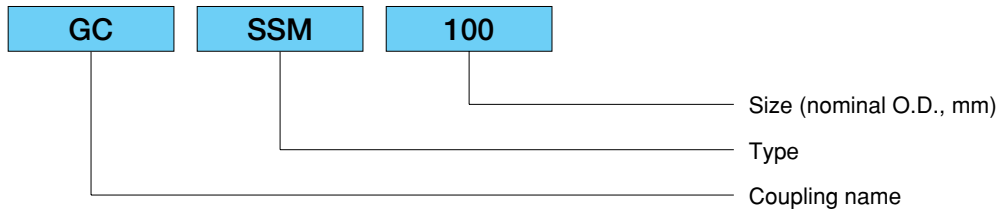

GC Coupling flexibility

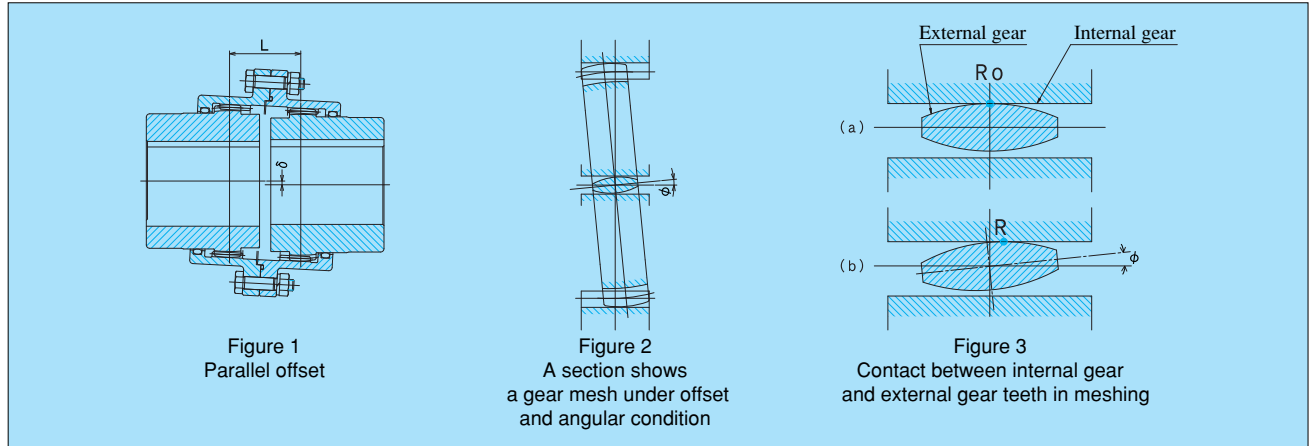

When offset misalignment exists, the coupling gear tooth tilts by $\tan \phi = \delta / L$ as shown in Figure 1. When the shafts are concentric, the gear tooth is in contact at the crowned tooth center (R_o) as shown in Figure 3(a). However, when the shafts have offset or angular misalignment after installation the gear tooth comes into contact at the point (R) away from the tooth center as shown in Figure 3(b). The larger the tilting angle is, the remoter the contact

point goes away from the center. Thus, the contact on arced surface ensures free and smooth meshing between internal gear and external gear under offset and angular misalignment. Our GC Couplings are designed and manufactured to have adequate crowning and backlash so that they can work freely and smoothly within allowable range.

1. Examples of misalignment

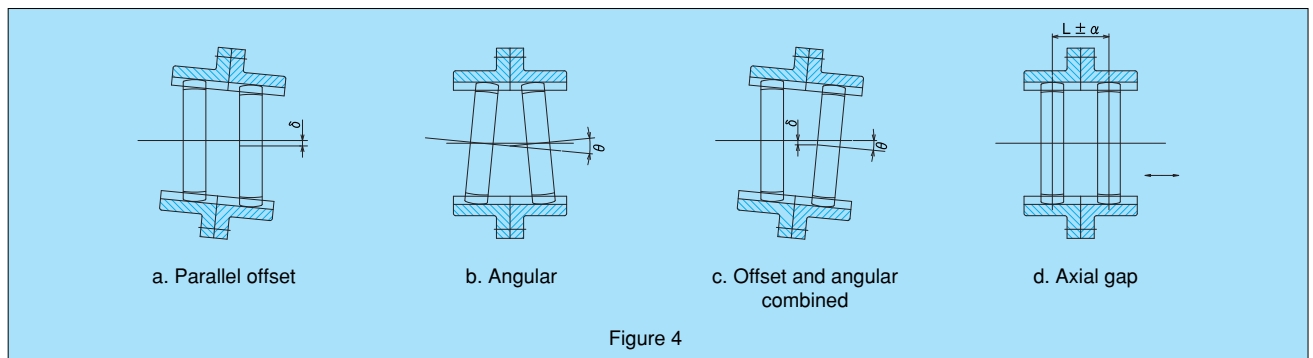

2. Allowable misalignment

The values in the tables below indicate the structurally allowable limits. It is, therefore, practically recommended that the alignment should be made as accurately as possible according to the service conditions such as the place of application, type of machine, service speed, etc. Recommended alignment target for longer working life: Less than 1/10 of the values shown in the table 2&3 below.

(a) Angular misalignment

Table 2

Type	Angular (θ)
GC-SSM,GC-SMM	3°
GC-CCM	2°
GC-MV	0.5°

Type	Angular (θ)
GC-SEM	1.5°
GC-CEM	1°

$\theta = 2 \phi$

(b) Offset misalignment and axial gap

Table 3

(Unit : mm)

GC-SSM type, GC-SMM type, GC-CCM type

Size No.	offset	Axial gap	Size No.	offset	Axial gap	Size No.	offset	Axial gap
100	0.75	-0.5~+1.0	355	3.0	-0.5~+5.5	1250	9.0	-0.5~+14.0
112	1.0	-0.5~+2.0	400	3.0	-0.5~+6.5	1400	10.0	-0.5~+16.5
125	1.0	-0.5~+2.5	450	3.0	-0.5~+5.0	1600	11.0	-0.5~+18.0
140	1.25	-0.5~+2.5	500	3.5	-0.5~+6.0			
160	1.25	-0.5~+3.0	560	4.0	-0.5~+6.5			
180	1.5	-0.5~+3.0	630	4.5	-0.5~+8.0			
200	1.5	-0.5~+3.0	710	5.0	-0.5~+8.5			
224	1.5	-0.5~+4.0	800	5.5	-0.5~+9.5			
250	2.0	-0.5~+4.0	900	6.5	-0.5~+10.5			
280	2.0	-0.5~+4.5	1000	7.0	-0.5~+12.0			
315	2.5	-0.5~+5.5	1120	8.0	-0.5~+13.0			

GC-SMV type, GC-SMVH type

Size No.	offset	Axial gap
100	0.6	-0.5~+1.0
112	0.6	-0.5~+1.0
125	0.6	-0.5~+1.5
140	0.6	-0.5~+1.5
160	0.6	-0.5~+1.5
180	0.6	-0.5~+1.5
200	0.6	-0.5~+1.5
224	0.6	-0.5~+2.0
250	1.0	-0.5~+2.0
280	1.0	-0.5~+2.5
315	1.0	-0.5~+3.0
355	1.0	-0.5~+3.0
400	1.0	-0.5~+3.5

Note: SEM and CEM types cannot accommodate the offset (δ) with a single unit. For these types, the axial gap (α) is a half of the value shown in the table.

SEM and CEM types should be applied with the two units in combination, using floating shaft as shown in Figure 5. In this case, offset misalignment should be determined from the following equation.

$$\tan \phi = \delta / L \text{ or } \delta = L \times \tan \phi$$

Usually taking as $L \doteq L'$

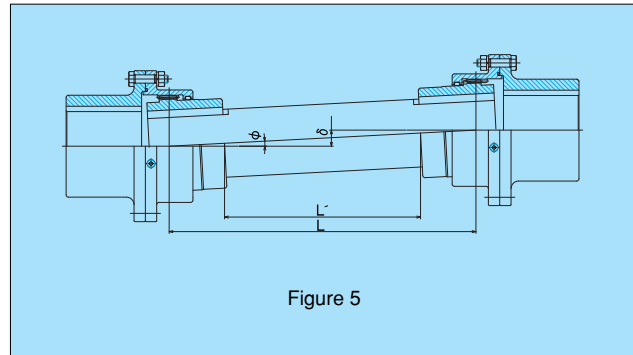

How to select

1. Determination of service factor S_1

⇒ According to Table 4 and Table 5

2. Determination of offset and Angular factor S_2

● In case that the shafts are designed without misalignment and are carefully aligned at the installation, $S_2=1.0$

● When the coupled shafts are so designed as to have offset or angular misalignment, determine S_2 as per Table 6

3. Determination of reversing factor S_3

⇒ One-way rotation $S_3=1.0$

For reversing service $S_3=1.5$

4. Calculation of transmitted capacity H or T

$$H = \frac{H_0 \times S_1 \times S_3}{S_2} \quad H_0 = \text{Transmitted power (kW)}$$

$$T = \frac{T_0 \times S_1 \times S_3}{S_2} \quad T_0 = \text{Transmitted torque (N-m, kgf-m)}$$

5. Size selection

⇒ Use the transmitted capacity tables on pages 12-15, 21 and 22.

(When rotational speed is not found in the tables, use interpolation to determine.)

6. Check bore

⇒ Use the dimensions tables on pages 16-24.

7. Check of maximum rotational speed

⇒ Use the transmitted capacity tables on pages 12-15, 21 and 22.

Table 4 Service factor ... S_1

Driving machine \ Driven machine	Driven machine		
	Uniform load	Variable load	Shock load
Uniform load	1.0	1.5	2.5
Light variable load	1.35	1.85	2.8
Variable load	1.7	2.2	3.0

Types of driving machine

- Uniform load Equipment using steam turbine or fluid coupling, and the motors excluding those mentioned below.
- Light variable load Motors with speed control (such as VVVF motor), equipment with belt drive or with frequent start and stop operations.
- Variable load Diesel engines with less than 6 cylinders.

Types of driven machine

- Uniform load Centrifugal blower, centrifugal compressor, centrifugal pump, etc.
- Variable load Blower, compressor and pump excluding those mentioned above and below, line shaft, reel winder, conveyor, etc.
- Shock load Cement kiln, shear, dryer, press, pulverizer, crane ; and reciprocating compressor, reciprocating pump, etc.

Table 5 Service factor S_1 for special application

Application condition	Service factor
Shaft system for transmission of high energy such as brake torque	4
Repeated shock loading such as encountered in diesel engine with extremely few cylinders, or in shaft system that frequently performs inching operation	5

Note: In the following cases, select in accordance with the method as described below, not using the table above.

- If a system peak torque (T_{max}) occurs less than 1000 times during the expected coupling life use the following formula.
Selection Torque $T = 1/2 \times T_{max}$

- Brake applications:
If the Torque rating of the brake exceeds the motor Torque, use the brake rating.
As follows:
Selection Torque $T = \text{brake torque}$

Table 6 Offset and Angular misalignment factor S_2

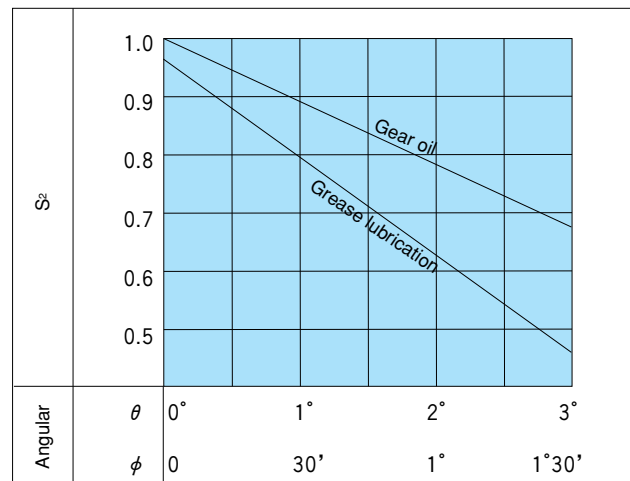

Calculate the Angular from the following formula to determine S_2 .

$$\tan \phi = \frac{\delta}{L}$$

where, δ is amount of offset misalignment.
 $L =$ Shown in Table 7 for standard types SSM, CCM, SMV, and CMV.
 When SEM or CEM is used in combination with floating shaft, use $L = L'$ (Figo 5).

Table 7 Dimension L

SSM, SMV	100	112	125	140	160	180	200	224	250	280	315	355	400
L (mm)	35	39	43	48	53	56	63	69	78	86	114	124	130
CCM, CMV	450	500	560	630	710	800	900	1000	1120	1250	1400	1600	
L (mm)	196	221	246	272	318	351	376	405	472	535	584	681	

[Example 1]

In case of a coupling being used as a shaft coupling for a municipal sewage pump driven by a direct-coupled diesel engine.

Specifications of Engine:

Shaft horsepower200kW
 Speed650rpm
 No. of cylinders6
 Shaft diameter80mm

Specifications of Pump:

Required horsepower190kW
 Speed650rpm
 Shaft diameter80mm
 Alignment;assuming no offset & angular misalignments.

Selection Steps:

From Table 4, Service Factor S_1 is 1.7.
 From Table 6, Offset & Angular Misalignment Factor S_2 is 1.0.
 From Selection Step 3, Reversing Factor S_3 is 1.0.
 From Selection Step 4, the basic rating for selection H can be obtained as follows:

$$H = \frac{190 \times 1.7 \times 1.0}{1.0} = 323 \text{ (kW)}$$

Since the starting load does not exceed 200% in this case, the above value can be taken as the basic rating for selection.

Since the operating speed at 650rpm is not listed in the Transmitting Power Ratings on page 12, convert the 323 kW at 650rpm into that at 750rpm as follows:

$$323 \times \frac{750}{650} = 373 \text{ (kW)}$$

From the "Transmitting Power Rating" on page 12, select the unit size SSM224 having the basic rating for selection over 373kW at 750rpm.

Further, considering the maximum bore of Type GC-SSM224 is 100mm, the use of Type GC-SSM224 is finally determined.

[Example 2]

Driving and Driven Machines:

An electric motor and a pinion stand for the rolls of a rolling mill

Specifications of Motor:

Transmitting horse power2,000kW
 Speed0~50/150rpm
 Shaft diameter630mm

Specifications of Pinion Stand:

Normal torque39tf·m
 Normal max. torque275%
 Emergency max. torque330%
 Shaft diameter630mm

Selection Steps:

For service factor, the emergency max. torque of 330% is applied.

For offset and angular misalignment factor, a value of 1.0 is applied tentatively.

It is, however, preferable to allow some margin in the basic rating for selection in view of a 24-hour continuous operation of the machine and possible land subsidence.

$$H = \frac{2000 \times 3.3}{1.0} = 6600 \text{ (kW)}$$

From the "Transmitting Power Rating" on page 13, the unit size CCM 1120 having over 6600kW at 50rpm is obtained, but the larger unit size, GC-CCM1250, is finally selected because of the shaft diameter being 630mm.

Instruction for size selection and usage

1. When shaft diameter smaller than minimum bore shown in the Dimentions Table is required, extra delivery time will be needed for custom production.
2. Unless otherwise specified, the product is supplied with rough stock bore.
 When JIS standard key is used with maximum bore diameter, the fitting tolerance should be within the H7n6 interference. Bore can be manufactured to the specified dimension if required. Standard finish tolerance is Class 7. When tapered machining is required, the taper gauge should be basically supplied by customer.
3. Strength of interference fit (including key and shrinkage fit, etc.) should be determined by customer.
4. For use in high speed revolution, the allowable max. speed of the coupling can be increased by adjusting the alignment and improving the balance of the coupling case.
5. When GC Coupling is filled with oil, apply sealing agent on key way to prevent oil leakage from the key way. **Oil seal cover** can be supplied upon request.
6. Normal ambient temperature are -10°C to 80°C. In case the temperature is out of the range, please consult with us.
7. When rigid combination is used (GC-EEM type), the alignment should be within 5/100mm.

Installation and maintenance

When installing GC Coupling, carefully follow the instructions below for optimum performance.

- Boring instructions:
Chuck Coupling Center (or Rigid), and to avoid damage to Coupling Center (or Rigid), use brass sheet between chuck jaws and Coupling Center (or Rigid). Check runout on front face and diameter. Tighten jaws and recheck runout of face and diameter.
- Clean all parts of coupling.
- Mount the Coupling Center on the shaft avoiding the damage to it. Place Coupling Cases, side covers and O-rings on the shaft before mounting the Coupling Center. Seal keyways to prevent from leakage with sealing agent, such as (HERMESEAL SS60F, SUPER THREEBOND, SONY BOND, CEMEDINE BATHCAULK).
- Perform the centering on the datum surfaces as accurately as possible, using feeler gauge and dial indicator. The performance and life of coupling depend upon alignment them, measuring misalignment are recommended less than 1/10 of the value shown in Table 2.
- Make sure there is no dust inside of the coupling case. Tighten the reamer bolts on the mating face evenly while taking care not to damage O-ring.
- When flush bolt is used inside, provide caulking or spot welding

Size No.	100	112	125	140	160	180	200	224	250	280	315	355	400
Tightening Torque N·m (kgf·m)	8.83~10.8 (0.9~1.1)		21.6~26.5 (2.2~2.7)		43.1~53.9 (4.4~5.5)		75.4~94.1 (7.6~9.6)		189~236 (19.3~24.1)				

Maintenance and check

- Check vibration or noise.
- Check lubricant leakage.
- Check tooth for damage.
- Check O-ring for deterioration or damage.
- Check lubricant deterioration.
- Check lubricant quantity loss.

to prevent loosening.
Supply and replacement of lubricant

a) Gear oil

Remove the two oil plugs. Supply the recommended lubricant from the upper plug hole until the oil flows out of the lower plug hole. Then, apply sealing agent (same as used on key way) or sealing tape to the plugs and tighten the plugs completely. The initial oil replacement should be done approx. 3 months after start of use. Disassemble the unit, drain the old oil, fully remove the abrasible particles of inside, and then supply the new oil. After the initial replacement, replenish add or change the oil from the plug hole it every 6 months.

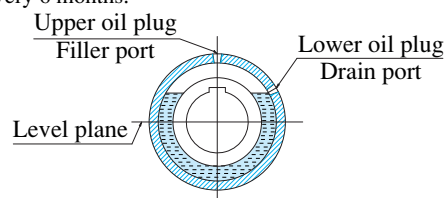

b) Grease

Supply the recommended grease with the amount enough to cover the teeth on the Coupling Case and the Center. Install the coupling and tighten the reamer bolts. Then, fill the additional grease from the oil plug hole using the device like grease gun. The time to change the grease is the same as that of gear oil, so the entire grease should be changed for fresh grease after the inside of the coupling has been cleaned thoroughly by means of disassembly.

Carry out the checks 1 and 2 regularly as they can be done from outside. Compare the status with normal condition. Carry out the rest of the checks periodically by disassembling the unit once in every 6 months. The inspection interval should be made shorter when such extreme conditions exist as high ambient temperature, overloading, reversing service and large misalignment.

Recommended lubricants

Lubricants

Use the JIS K2219 industrial-use Class 2 gear oil, (ISO VG680), the AGMA #8EP (ISO VG680) or equivalent.

Use the JIS K2220 centralized lube grease Class 4 No. 1 with extreme-pressure additive, the NLGI #1EP grease, or equivalent. Use the high viscosity gear oil (70-110cst at 98.9°C) especially when such extreme conditions exist as high ambient temperature, overloading, severe reversing and excessive misalignment.

Recommended lubricants

GC Coupling

Maker	Gear Oil	Grease
Idemitsu Kosan	Daphne Super Gear Oil 680	Daphne Eponex Grease EP1
Exxon Mobil	SPARUTAN EP680 Mobil Gear 636	Squirrel tangeEPO Mobil Lux EP1
Cosmo Oil	Cosmo Gear SE680	Cosmo Concentration Grease NO.1
Showa Shell Sekiyu	Sell Omala Oil 680	Sell Alvania Grease EP1
Tonen General Sekiyu	General SP Gear Roll 680	ZEMIKO Grease ME1
NIPPON OIL	NIPPON OIL CORPORATION BONNOKKU M680	EPINOCK Grease AP1

Lubricant quantities

GC-SSM, GC-SEM

Size No.	GC-SSM		GC-SEM	
	Gear oil (ℓ)	Grease (g)	Gear oil (ℓ)	Grease (g)
100	0.043	38	0.032	29
112	0.055	50	0.042	38
125	0.072	65	0.056	51
140	0.11	100	0.085	77
160	0.14	130	0.11	100
180	0.18	160	0.14	130
200	0.24	220	0.18	170
224	0.36	320	0.29	270
250	0.53	480	0.41	370
280	0.69	620	0.56	510
315	1.1	1,000	0.9	810
355	1.3	1,200	1.1	1,000
400	2.0	1,800	1.6	1,440

GC-CCM, GC-CEM

Size No.	GC-CCM		GC-CEM	
	Gear oil (ℓ)	Grease (kg)	Gear oil (ℓ)	Grease (kg)
450	2.6	2.3	2.1	1.9
500	3.8	3.4	3.1	2.8
560	4.6	4.1	3.8	3.5
630	6.7	6.0	5.8	5.3
710	9.4	8.4	7.8	7.0
800	13	11.5	11	10
900	17	15	14	13
1000	23	20	20	18
1120	31	27	26	24
1250	45	40	37	34
1400	66	59	55	50
1600	94	84	76	69

(kW for top,
Unit: N-m for center,
kgf-m for bottom lines)

GC-SSM type, GC-SEM type, GC-SMV type

Size No.	Shaft dia. Max/Min	Max. allowable rotational speed (rpm)	Reference torque N-m (kgf-m)	Rotational speed (rpm)										
				100	200	500	750	1000	1200	1500	1800	3000	3600	4000
100	32/17	4000	421 (43.0)	4.1	8.1	18.4	26.6	34.5	40.5	49.3	57.8	89.1	104	113
				387 (39.5)	385 (39.3)	352 (35.9)	339 (34.6)	329 (33.6)	323 (32.9)	314 (32.0)	306 (31.3)	284 (28.9)	275 (28.1)	270 (27.6)
112	40/17	4000	788 (80.3)	7.5	14.5	33.8	48.8	63.0	73.9	89.7	105	161	187	204
				718 (73.2)	692 (70.6)	646 (65.9)	621 (63.3)	602 (61.3)	588 (60.0)	571 (58.2)	557 (56.8)	513 (52.3)	496 (50.6)	486 (49.6)
125	50/22	4000	1400 (142)	13.2	25.4	59.1	84.9	109	128	155	181	277	321	350
				1260 (129)	1210 (124)	1130 (115)	1080 (110)	1045 (106)	1020 (104)	989 (101)	962 (98.1)	882 (90.0)	853 (86.9)	835 (85.1)
140	56/22	4000	2010 (205)	18.9	36.2	83.7	120	154	180	218	254	387	448	487
				1800 (184)	1730 (176)	1600 (163)	1530 (156)	1470 (150)	1440 (146)	1390 (142)	1350 (138)	1230 (126)	1190 (121)	1160 (118)
160	65/22	4000	3080 (314)	28.7	54.9	126	181	232	271	328	381	578	668	725
				2740 (280)	2620 (268)	2420 (246)	2300 (235)	2220 (226)	2160 (220)	2090 (213)	2020 (206)	1840 (188)	1770 (181)	1730 (177)
180	75/32	4000	4730 (482)	43.8	83.7	192	274	351	410	494	575	868	1000	1090
				4190 (427)	4000 (407)	3660 (374)	3490 (356)	3350 (342)	3260 (333)	3150 (321)	3050 (311)	2760 (282)	2660 (271)	2600 (265)
200	85/32	3810	6750 (689)	62.2	118	270	385	493	575	692	804	1210	1390	
				5940 (605)	5650 (577)	5170 (527)	4910 (500)	4710 (480)	4570 (466)	4410 (449)	4270 (435)	3850 (393)	3700 (377)	
224	100/42	3410	9810 (1000)	89.3	169	384	546	696	811	974	1130	1690		
				8530 (870)	8090 (825)	7340 (749)	6950 (709)	6650 (678)	6450 (658)	6200 (633)	5990 (611)	5380 (549)		
250	115/42	3050	14400 (1470)	130	246	554	784	998	1160	1390	1610	2400		
				12400 (1265)	11700 (1200)	10600 (1080)	9990 (1020)	9530 (972)	9240 (942)	8860 (904)	8550 (871)	7640 (779)		
280	135/42	2720	22900 (2340)	205	386	866	1220	1550	1800	2160	2490			
				19500 (1990)	18400 (1880)	16500 (1690)	15600 (1590)	14800 (1510)	14300 (1460)	13700 (1400)	13200 (1350)			
315	160/100	2420	36100 (3680)	319	598	1330	1880	2380	2750	3290	3800			
				30400 (3100)	28600 (2910)	25500 (2600)	23900 (2440)	22700 (2320)	21900 (2240)	21000 (2140)	20100 (2050)			
355	180/125	2150	54400 (5550)	476	892	1980	2780	3520	4070	4860	5600			
				45500 (4640)	42600 (4340)	37800 (3860)	35400 (3610)	33600 (3420)	32400 (3300)	30900 (3150)	29700 (3030)			
400	200/140	1900	76400 (7790)	661	1230	2720	3810	4800	5550	6610	7610			
				63100 (6440)	58900 (6010)	52000 (5300)	48500 (4940)	45900 (4680)	44200 (4510)	42100 (4290)	40400 (4120)			

Note: 1. Consult us when rotational speed is lower than 100rpm.

※ Size number marked with ● is in stock.

(kW for top,
Unit: kN-m for center,
tf-m for bottom lines)

GC-CCM type, GC-CEM type, GC-CMV type

Size No.	Shaft dia. Max/Min	Max. allowable rotational speed (rpm)	Reference torque kN-m (tf-m)	Rotational speed (rpm)									
				1	10	50	75	100	250	500	1000	1200	1500
450	205/140	1690	108 (11.0)	11.3	106	491	716	932	2110	3830	6760	7810	9300
				106 (10.8)	101 (10.3)	93.8 (9.6)	91.2 (9.3)	89.0 (9.1)	80.8 (8.2)	73.2 (7.5)	64.6 (6.6)	62.2 (6.3)	59.2 (6.0)
500	250/170	1520	163 (16.6)	16.7	159	733	1070	1390	3130	5630	9880	11400	13500
				159 (16.2)	152 (15.5)	140 (14.3)	136 (13.8)	132 (13.5)	119 (12.2)	108 (11.0)	94.4 (9.6)	90.8 (9.3)	86.3 (8.8)
560	280/190	1360	250 (25.5)	25.6	243	1120	1620	2110	4730	8480	14800	17100	
				244 (24.9)	232 (23.7)	214 (21.8)	207 (21.1)	201 (20.5)	181 (18.4)	162 (16.5)	141 (14.4)	136 (13.8)	
630	325/224	1210	412 (42.0)	42.0	398	1820	2630	3410	7600	13600	23500	27000	
				401 (40.9)	380 (38.8)	347 (35.4)	335 (34.2)	326 (33.2)	291 (29.6)	259 (26.4)	224 (22.9)	215 (21.9)	
710	360/250	1070	600 (61.2)	61.1	577	2620	3790	4900	10900	19300	33200		
				584 (59.5)	551 (56.2)	500 (51.0)	482 (49.2)	468 (47.8)	415 (42.4)	368 (37.6)	318 (32.4)		
800	405/280	950	858 (87.5)	87.3	821	3710	5360	6930	15300	27000			
				834 (85.0)	785 (80.0)	709 (72.3)	683 (69.6)	662 (67.5)	584 (59.5)	516 (52.6)			
900	475/315	840	1220 (125)	124	1160	5220	7510	9690	21200	37300			
				1180 (121)	1110 (113)	996 (102)	957 (97.5)	926 (94.4)	811 (82.7)	712 (72.6)			
1000	510/355	760	1680 (171)	170	1590	7110	10200	13200	28800	50300			
				1620 (165)	1520 (155)	1360 (138)	1300 (133)	1260 (128)	1100 (112)	962 (98.1)			
1120	600/400	682	2360 (240)	239	2220	9850	14100	18200	39400	68600			
				2280 (233)	2120 (216)	1880 (192)	1800 (184)	1740 (177)	1510 (154)	1310 (134)			
1250	710/500	610	3250 (331)	339	3140	13900	19800	25500	54900	94900			
				3240 (331)	3000 (306)	2650 (270)	2530 (258)	2430 (248)	2100 (214)	1810 (185)			
1400	800/560	540	4480 (457)	470	4470	19600	28000	35900	76900	132000			
				4480 (457)	4270 (436)	3750 (382)	3570 (364)	3430 (350)	2940 (300)	2530 (258)			
1600	900/630	470	6460 (658)	676	6330	27500	39200	50100	106000				
				6460 (658)	6040 (616)	5250 (536)	4990 (509)	4790 (488)	4070 (415)				

※ Size number marked with ● is in stock.

※ For the application conditions in excess of the transmission power and the rotational speeds shown here, other series can comply with your requirements. Consult us by giving the required application conditions.

(Examples) For generator drive: 30,000kW 1,800rpm

For converter inclination: 800tf-m 0.1rpm

(kW for top,
Unit: N-m for center,
kgf-m for bottom lines)

GC-SSMH type, GC-SEMH type, GC-SMVH type

Size No.	Shaft dia. Max/Min	Max. allowable rotational speed (rpm)	Reference torque N-m (kgf-m)	Rotational speed (rpm)										
				100	200	500	750	1000	1200	1500	1800	3000	3600	4000
100	32/17	4000	802 (81.7)	7.7	15.3	35.0	50.7	65.6	77.1	93.7	110	170	197	215
				736 (75.1)	733 (74.7)	669 (68.2)	645 (65.8)	626 (63.9)	613 (62.5)	597 (60.9)	583 (59.4)	540 (55.0)	523 (53.4)	514 (52.4)
112	40/17	4000	1420 (145)	14.7	28.3	66.1	95.3	123	144	175	205	315	365	398
				1400 (143)	1350 (138)	1260 (129)	1210 (124)	1180 (120)	1150 (117)	1120 (114)	1090 (111)	1000 (100)	970 (98.9)	950 (96.9)
125	50/22	4000	2410 (246)	24.9	47.8	111	160	206	241	292	341	521	604	658
				2380 (242)	2280 (233)	2120 (216)	2030 (207)	1970 (200)	1920 (196)	1860 (190)	1810 (185)	1660 (169)	1600 (164)	1570 (160)
140	56/22	4000	3540 (371)	37.4	71.8	166	238	306	358	433	504	767	887	965
				3580 (365)	3430 (350)	3170 (323)	3030 (309)	2920 (298)	2850 (290)	2750 (281)	2680 (273)	2440 (249)	2350 (240)	2300 (235)
160	65/22	4000	5090 (519)	53.2	106	262	374	480	561	678	789	1200	1380	1500
				5090 (519)	5090 (519)	5000 (510)	4770 (486)	4590 (468)	4470 (456)	4320 (440)	4190 (427)	3810 (388)	3670 (374)	3580 (365)
180	75/32	4000	7730 (788)	80.9	162	386	551	706	824	994	1160	1750	2010	2190
				7730 (788)	7730 (788)	7370 (752)	7020 (715)	6740 (688)	6560 (669)	6330 (645)	6130 (625)	5560 (567)	5350 (545)	5220 (532)
200	85/32	3810	12700 (1290)	122	233	531	757	969	1130	1360	1580	2380	2740	
				11700 (1190)	11100 (1130)	10200 (1040)	9640 (983)	9250 (943)	8990 (917)	8660 (883)	8380 (855)	7570 (772)	7270 (742)	
224	100/42	3410	17800 (1820)	180	342	776	1100	1410	1640	1970	2280	3410		
				17200 (1760)	16300 (1670)	14800 (1510)	14000 (1430)	13400 (1370)	13000 (1330)	12500 (1280)	12100 (1230)	10900 (1110)		
250	115/42	3050	24200 (2470)	252	477	1080	1520	1940	2250	2700	3130	4660		
				24100 (2460)	22800 (2320)	20600 (2100)	19400 (1980)	18500 (1890)	17900 (1830)	17200 (1750)	16600 (1690)	14800 (1510)		
280	135/42	2720	32300 (3290)	337	675	1690	2530	3210	3730	4460	5160			
				32200 (3290)	32200 (3290)	32200 (3290)	32200 (3280)	30700 (3130)	29700 (3030)	28400 (2900)	27400 (2790)			
315	160/100	2420	49700 (5070)	520	1040	2600	3760	4760	5520	6600	7610			
				49700 (5070)	49700 (5070)	49700 (5070)	47900 (4880)	45500 (4640)	43900 (4480)	42000 (4280)	40400 (4120)			
355	180/125	2150	65800 (6710)	689	1380	3440	5170	6890	7990	9530	11000			
				65800 (6710)	65800 (6710)	65800 (6710)	65800 (6710)	65800 (6710)	63500 (6480)	60700 (6190)	58300 (5940)			
400	200/140	1900	92400 (9430)	968	1940	4840	7260	9590	11100	13200	15200			
				92400 (9430)	92400 (9430)	92400 (9430)	92400 (9430)	91900 (9335)	88200 (8990)	84000 (8560)	80600 (8210)			

Note: 1. Consult us when rotational speed is lower than 100rpm.

2. The table applies to the reinforcement type (MH type) after heat treatment to M series.

(kW for top,
Unit: kN-m for center,
tf-m for bottom lines)

GC-CCMH type, GC-CEMH type, GC-CMVH type

Size No.	Shaft dia. Max/Min	Max. allowable rotational speed (rpm)	Reference torque kN-m (tf-m)	Rotational speed (rpm)									
				1	10	50	75	100	250	500	1000	1200	1500
450	205/140	1690	174 (17.7)	18.2	182	912	1370	1820	4290	7780	13700	15900	18900
				174 (17.7)	174 (17.7)	174 (17.7)	174 (17.7)	174 (17.7)	164 (16.7)	149 (15.2)	131 (13.4)	126 (12.9)	120 (12.3)
500	250/170	1520	261 (26.7)	27.4	274	1370	2060	2740	6350	11400	20100	23200	27500
				262 (26.7)	262 (26.7)	262 (26.7)	262 (26.7)	262 (26.7)	243 (24.7)	219 (22.3)	192 (19.6)	184 (18.8)	175 (17.9)
560	280/190	1360	408 (41.5)	42.6	426	2130	3200	4260	9600	17200	30100	34600	
				408 (41.5)	408 (41.5)	408 (41.5)	408 (41.5)	408 (41.5)	367 (37.4)	329 (33.6)	287 (29.3)	276 (28.1)	
630	325/224	1210	581 (59.2)	60.8	608	3040	4560	6080	15200	27500	47700	54900	
				581 (59.2)	581 (59.2)	581 (59.2)	581 (59.2)	581 (59.2)	581 (59.2)	526 (53.6)	456 (46.5)	437 (44.5)	
710	360/250	1070	789 (80.5)	82.6	826	4130	6160	7970	17700	31300	54000		
				789 (80.5)	789 (80.5)	789 (80.5)	784 (80.0)	761 (77.6)	675 (68.8)	599 (61.1)	516 (52.6)		
800	405/280	950	1110 (113)	116	1160	5800	8710	11300	24800	43900			
				1110 (113)	1110 (113)	1110 (113)	1110 (113)	1080 (110)	949 (96.8)	838 (85.5)			
900	475/315	840	1510 (154)	159	1590	7930	11900	15800	34500	60600			
				1510 (154)	1510 (154)	1510 (154)	1510 (154)	1500 (153)	1320 (134)	1160 (118)			
1000	510/355	760	1970 (200)	206	2060	10300	15500	20600	46800	81800			
				1970 (200)	1970 (200)	1970 (200)	1970 (200)	1970 (200)	1790 (182)	1560 (159)			
1120	600/400	682	2450 (249)	256	2560	12800	19200	25600	61600	107000			
				2450 (249)	2450 (249)	2450 (249)	2450 (249)	2450 (249)	2350 (240)	2050 (209)			
1250	710/500	610	3250 (331)	340	3400	17000	25500	33400	85000	148000			
				3250 (331)	3250 (331)	3250 (331)	3250 (331)	3250 (331)	3250 (331)	2830 (289)			
1400	800/560	540	4490 (457)	470	4700	23500	35200	47000	117000	207000			
				4490 (457)	4490 (457)	4490 (457)	4490 (457)	4490 (457)	4490 (457)	3950 (403)			
1600	900/630	470	6460 (658)	676	6760	33800	50700	67600	166000				
				6460 (658)	6460 (658)	6460 (658)	6460 (658)	6460 (658)	6350 (648)				

Note: 1. The table applies to the reinforcement type (MH type) after heat treatment to M series.

※ Size number marked with ● is in stock.

※ For the application conditions in excess of the transmission power and the rotational speeds shown here, other series can comply with your requirements. Consult us by giving the required application conditions.

(Examples) For generator drive: 30,000kW 1,800rpm

For converter inclination: 800tf-m 0.1rpm

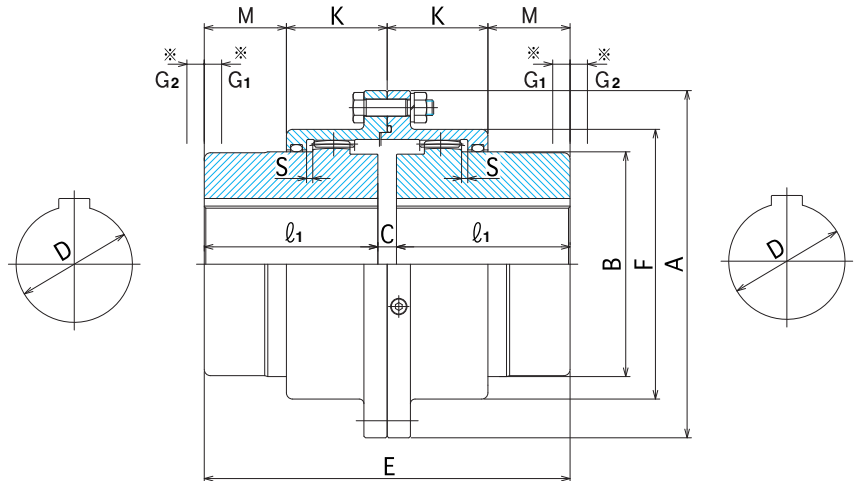
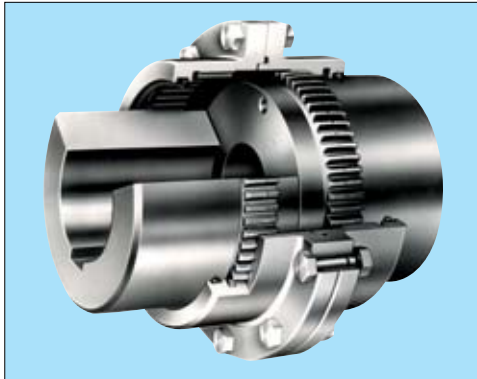
GC-SSM type GC-SSMH type
 (Double Engagement)

※ G₁ indicates the Coupling Case position at the time of centering.

※ G₂ indicates the Coupling Case position at the time of tooth inspection.

Size No	Shaft dia. (mm)	Dimensions (mm)										Lubricant capacity (ℓ)	Weight (kg)	GD ² (kgf-m ²)
O.D. (mm) A	Max/Min D	E	ℓ ₁	C	B	F	K	M	S	G ₁	G ₂			
100	32/17	98	45	8	46	67	34	15	2	4	10	0.043	2.9	0.0112
112	40/17	108	50	8	58	79	40	14	2	1	14	0.055	4.3	0.0198
125	50/22	134	63	8	70	92	43	24	2.5	9	7	0.072	6.6	0.0353
140	56/22	150	71	8	80	107	47	28	2.5	11	7	0.11	9.3	0.0612
160	65/22	170	80	10	95	120	52	33	3	12	7	0.14	14	0.113
180	75/32	190	90	10	105	134	56	39	3	15	5	0.18	19	0.191
200	85/32	210	100	10	120	149	61	44	3	18	5	0.24	26	0.315
224	100/42	236	112	12	145	174	65	53	4	25	1	0.36	39	0.599
250	115/42	262	125	12	165	200	74	57	4	28	1	0.53	55	1.08
280	135/42	294	140	14	190	224	82	65	4.5	28	1	0.69	81	2.06
315	160/100	356	170	16	225	260	98	80	5.5	33	1	1.1	129	4.24
355	180/125	396	190	16	250	288	108	90	5.5	34	1	1.3	177	7.13
400	200/140	418	200	18	285	329	114	95	6.5	39	0	2.0	242	12.5

Note: 1. Weight and GD² are the values for solid shaft.

GC-SEM type GC-SEMH type (Single Engagement and floating shaft)

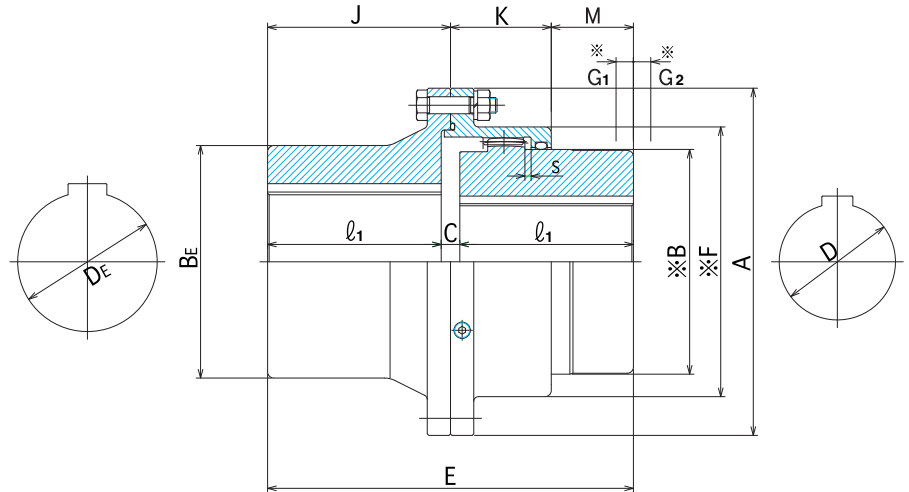
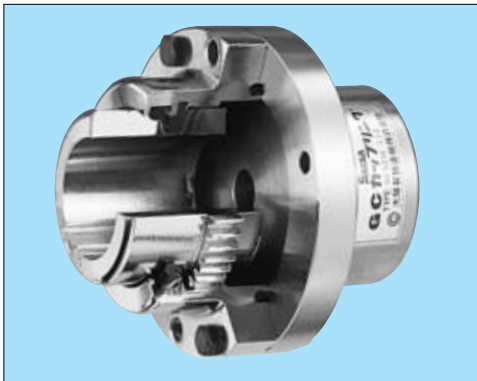

※ Dimensions B and F are the same as those of GC-SSM type.
 ※ G1 indicates the Coupling Case position at the time of centering.
 ※ G2 indicates the Coupling Case position at the time of tooth inspection.

Size No	Shaft dia. (mm)		Dimensions (mm)										Lubricant capacity (l)	Weight (kg)	GD ² (kgf-m ²)
	Max/Min D	Max/Min D _E	E	l ₁	C	K	M	J	B _E	S	G ₁	G ₂			
100	32/17	40/17	98	45	8	34	15	49	55	2	4	10	0.032	3.0	0.0110
112	40/17	50/17	108	50	8	40	14	54	70	2	1	14	0.042	4.6	0.0197
125	50/22	56/22	134	63	8	43	24	67	80	2.5	9	7	0.056	6.7	0.0348
140	56/22	63/22	150	71	8	47	28	75	90	2.5	11	7	0.085	9.3	0.0591
160	65/22	75/22	170	80	10	52	33	85	105	3	12	7	0.11	14	0.111
180	75/32	80/32	190	90	10	56	39	95	115	3	15	5	0.14	19	0.183
200	85/32	95/32	210	100	10	61	44	105	135	3	18	5	0.18	26	0.317
224	100/42	105/42	236	112	12	65	53	118	150	4	25	1	0.29	38	0.579
250	115/42	125/42	262	125	12	74	57	131	180	4	28	1	0.41	56	1.08
280	135/42	150/42	294	140	14	82	65	147	210	4.5	28	1	0.56	83	2.14
315	160/100	180/100	356	170	16	98	80	178	250	5.5	33	1	0.90	135	4.55
355	180/125	200/125	396	190	16	108	90	198	275	5.5	34	1	1.1	184	7.50
400	200/140	236/140	418	200	18	114	95	209	325	6.5	39	0	1.6	261	14.1

Note: 1. Weight and GD² are the values for solid shaft.

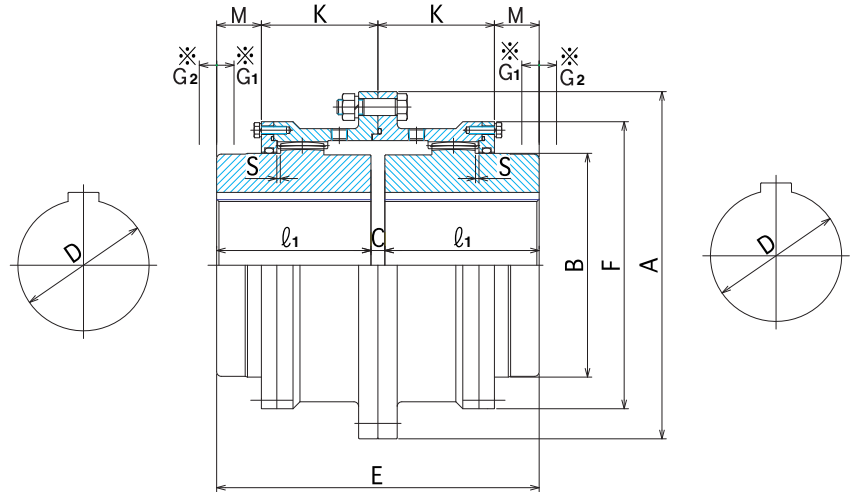
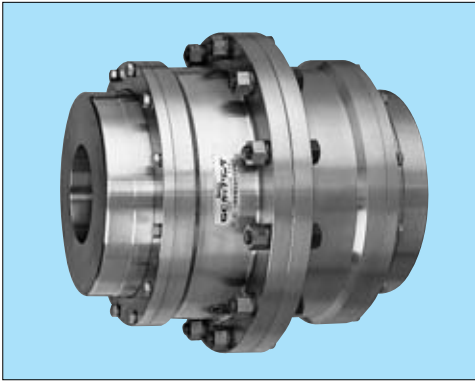
GC-CCM type GC-CCMH type
 (Double Engagement / Side Cover)

※ G₁ indicates the Coupling Case position at the time of centering.

※ G₂ indicates the Coupling Case position at the time of tooth inspection.

Size No	Shaft dia. (mm)	Dimensions (mm)										Lubricant capacity (ℓ)	Weight (kg)	GD ² (kgf-m ²)
O.D. (mm) A	Max/Min D	E	ℓ ₁	C	B	F	K	M	S	G ₁	G ₂			
450	205/140	418	200	18	290	372	151	58	5	-3	6	2.6	298	16.6
500	250/170	494	236	22	335	424	168	79	6	10	-5	3.8	446	36.9
560	280/190	552	265	22	385	472	187	89	6.5	7	-2	4.6	642	67.6
630	325/224	658	315	28	455	544	213	116	8	17	-10	6.7	1010	137
710	360/250	738	355	28	510	622	242	127	8.5	17	-10	9.4	1440	250
800	405/280	832	400	32	570	690	267	149	9.5	23	-15	13	2030	441
900	475/315	932	450	32	670	792	295	171	10.5	27	-30	17	3030	860
1000	510/355	1040	500	40	720	858	322	198	12	40	-30	23	4120	1380
1120	600/400	1160	560	40	840	990	360	220	13	55	-45	31	5920	2650
1250	710/500	1460	710	40	960	1126	399	331	14	150	-140	45	9410	5290
1400	800/560	1650	800	50	1070	1255	449	376	16.5	170	-160	66	13200	9280
1600	900/630	1850	900	50	1260	1450	503	422	18	200	-190	94	21000	18900

Note: 1. Weight and GD² are the values for solid shaft.

GC-CEM type GC-CEMH type (Single engagement and floating shaft)

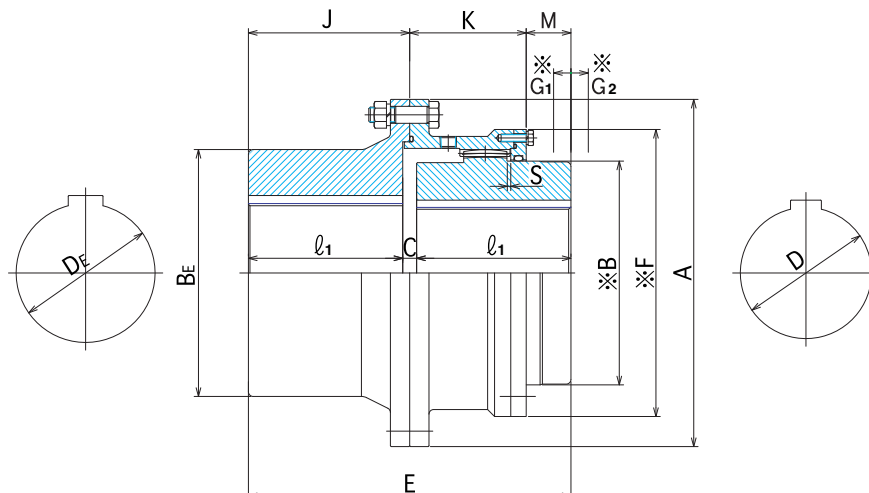

※ Dimensions B and F are the same as those of GC-CCM type.
 ※ G₁ indicates the Coupling Case position at the time of centering.
 ※ G₂ indicates the Coupling Case position at the time of tooth inspection.

Size No	Shaft dia. (mm)		Dimensions (mm)										Lubricant capacity (ℓ)	Weight (kg)	GD ² (kgf-m ²)
	Max/Min D	Max/Min D _E	E	l ₁	C	K	M	J	*B _E	S	G ₁	G ₂			
450	205/140	225/140	418	200	18	151	58	209	320	5	-3	80	2.1	304	18.2
500	250/170	270/170	494	236	22	168	79	247	380	6	10	80	3.1	453	37.0
560	280/190	305/190	552	265	22	187	89	276	430	6.5	7	80	3.8	664	70.0
630	325/224	355/224	658	315	28	213	116	329	500	8	17	80	5.8	1020	139
710	360/250	400/250	738	355	28	242	127	369	565	8.5	17	90	7.8	1460	252
800	405/280	450/280	832	400	32	267	149	416	635	9.5	23	90	11	2090	451
900	475/315	510/315	932	450	32	295	171	466	715	10.5	27	90	14	3020	743
1000	510/355	570/355	1040	500	40	322	198	520	800	12	40	100	20	4130	1440
1120	600/400	640/400	1160	560	40	360	220	580	900	13	55	100	26	5970	2810
1250	710/500	800/500	1460	710	40	399	331	730	1060	14	150	100	37	9820	5630
1400	800/560	900/560	1650	800	50	449	376	825	1180	16.5	170	100	55	13800	9870
1600	900/630	1000/630	1850	900	50	503	422	925	1350	18	200	100	76	20600	19400

Note: 1. Weight and GD² are the values for solid shaft.
 2. The dimension *B_E may be changed to the dimension B (as shown on page 18) depending on the shaft diameter.

GC-SMV, SMVH types

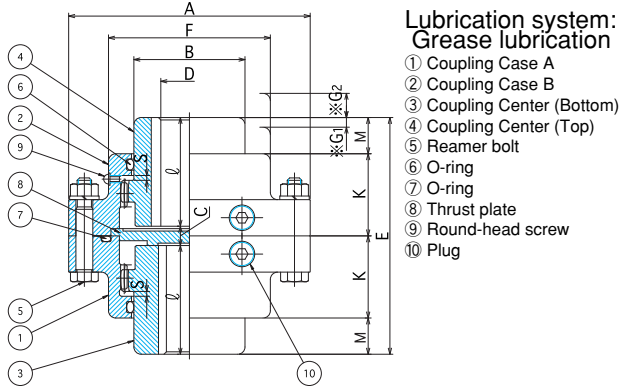

GC-CMV, CMVH types

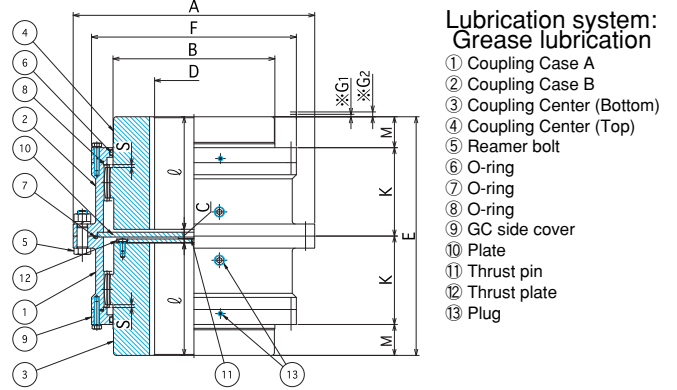

※ G₁ indicates the Coupling Case position at the time of centering.
 ※ G₂ indicates the Coupling Case position at the time of tooth inspection.

GC-SMV, SMVH types

Size No	Shaft dia. (mm)	Dimensions (mm)										Lubricant capacity (g) Top/Bottom	Weight (kg)	GD ² (kgf·m ²)
		O.D. (mm) A	Max/Min D	E	ℓ	C	B	F	K	M	S			
100	27/17	98	45	8	46	67	34	15	2	4	10	14/12	3.0	0.0114
112	40/17	108	50	8	58	79	40	14	2	1	14	20/16	4.4	0.0200
125	50/22	134	63	8	70	92	43	24	2.5	9	7	28/21	6.7	0.0358
140	56/22	150	71	8	80	107	47	28	2.5	11	7	47/39	9.5	0.0621
160	65/22	170	80	10	95	120	52	33	3	12	7	55/39	14	0.115
180	75/32	190	90	10	105	134	56	39	3	15	5	68/50	19	0.194
200	85/32	210	100	10	120	149	61	44	3	18	5	92/64	27	0.32
224	100/42	236	112	12	145	174	65	53	4	25	1	140/86	40	0.611
250	115/42	262	125	12	165	200	74	57	4	28	1	220/160	56	1.10
280	135/42	294	140	14	190	224	82	65	4.5	28	1	280/180	83	2.1
315	160/100	356	170	16	225	260	98	80	5.5	33	1	490/320	131	4.31
355	180/125	396	190	16	250	288	108	90	5.5	34	1	640/400	180	7.25
400	200/140	418	200	18	285	329	114	95	6.5	39	0	890/570	246	12.7

Note: Weight and GD² are the values for solid boss.

GC-CMV, CMVH types

※ G₁ indicates the Coupling Case position at the time of centering.
 ※ G₂ indicates the Coupling Case position at the time of tooth inspection.

Size No	Shaft dia. (mm)	Dimensions (mm)										Lubricant capacity (kg) Top/Bottom	Weight (kg)	GD ² (kgf·m ²)
		O.D. (mm) A	Max/Min D	E	ℓ	C	B	F	K	M	S			
450	205/140	424	200	24	290	372	166	46	4	18	23	1.3/1.2	312	21.1
500	250/170	500	236	28	335	424	183	67	5	5	10	2.1/1.8	462	38.8
560	280/190	558	265	28	385	472	202	77	5.5	8	13	2.6/2.1	662	70.2
630	325/224	658	315	28	455	544	230	99	8	0	7	3.4/2.8	1040	143

Note: Weight and GD² are the values for solid boss.

GC-EEM type

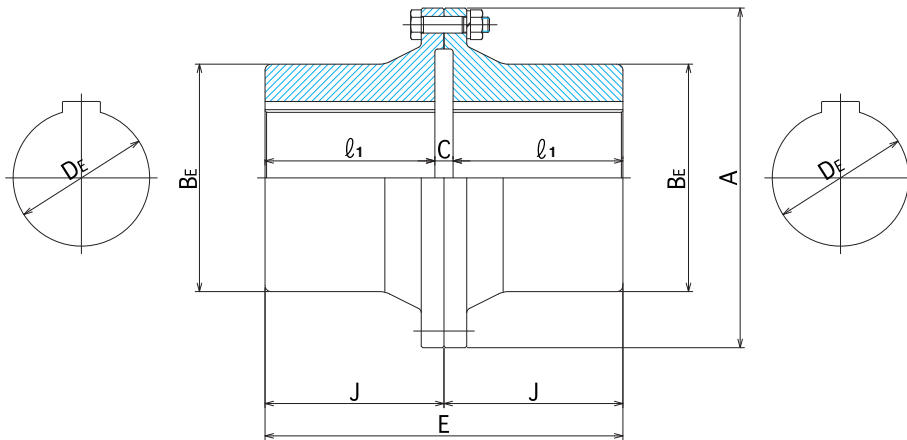

Size No.	Transmission torque N·m (kgf·m)	Max. allowable rotation (rpm)	Shaft dia. (mm)	Dimensions (mm)					Weight (kg)	GD ² (kgf·m ²)
O.D. (mm) A			Max/Min D _E	E	l ₁	C	J	B _E		
100	491 (50.1)	4000	40/ 17	98	45	8	49	55	3.1	0.0108
112	962 (98.1)	4000	50/ 17	108	50	8	54	70	4.9	0.0196
125	1640 (167.5)	4000	56/ 22	134	63	8	67	80	6.8	0.0343
140	2490 (254.2)	4000	63/ 22	150	71	8	75	90	9.3	0.0570
160	3900 (398.1)	4000	75/ 22	170	80	10	85	105	14	0.109
180	5940 (606.2)	4000	80/ 32	190	90	10	95	115	19	0.175
200	8300 (846.0)	3810	95/ 32	210	100	10	105	135	26	0.319
224	12380 (1262)	3410	105/ 42	236	112	12	118	150	37	0.559
250	16770 (1710)	3050	125/ 42	262	125	12	131	180	57	1.08
280	29030 (2960)	2720	150/ 42	294	140	14	147	210	85	2.22
315	37660 (3840)	2420	180/100	356	170	16	178	250	141	4.86
335	56490 (5760)	2150	200/125	396	190	16	198	275	191	7.87
400	79340 (8090)	1900	236/140	418	200	18	209	325	280	15.7

Note: 1. Weight and GD² are the values for solid shaft.

2. Material and dimensions are the same as those in GC-M series.

3. Interchangeability with GC-SSM and GC-SEM are secured.

※ Size number marked with ● is in stock.

GC-EEM type

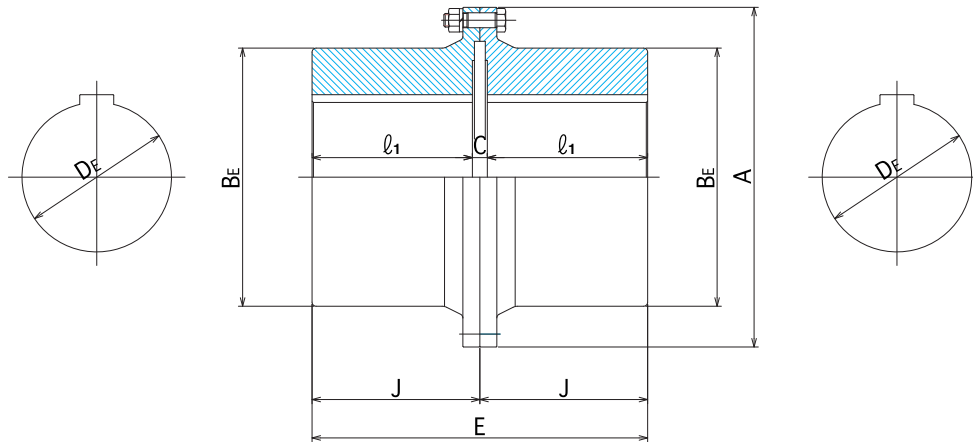

Size No.	Transmission torque kN·m (tf·m)	Max. allowable rotation (rpm)	Shaft dia. (mm)	Dimensions (mm)					Weight (kg)	GD ² (kgf·m ²)
O.D. (mm) A			Max/Min De	E	l ₁	C	J	BE		
450	135 (13.8)	1690	225/140	418	200	18	209	320	310	19.8
500	226 (23.0)	1520	270/170	494	236	22	247	380	460	37.1
560	337 (34.4)	1360	305/190	552	265	22	276	430	686	72.4
630	569 (58.0)	1210	355/224	658	315	28	329	500	1030	141
710	789 (80.5)	1070	400/250	738	355	28	369	565	1480	254
800	1110 (113)	950	450/280	832	400	32	416	635	2150	461
900	1510 (154)	840	510/315	932	450	32	466	715	3010	626
1000	1970 (201)	760	570/355	1040	500	40	520	800	4140	1500
1120	2440 (249)	682	640/400	1160	560	40	580	900	6020	2970
1250	3250 (331)	610	800/500	1460	710	40	730	1060	10230	5970
1400	4490 (458)	540	900/560	1650	800	50	825	1180	14400	10460
1600	6450 (658)	470	1000/630	1850	900	50	925	1350	20200	19900

Note: 1. Weight and GD² are the values for solid shaft.

2. Material and dimensions are the same as those in GC-M series.

※ Size number marked with ● is in stock.

With oil seal cover (Apply to single keyway only)

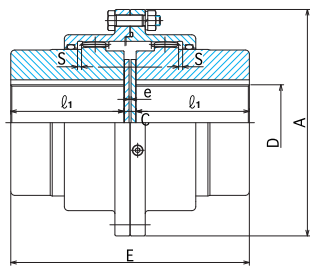

GC-SSM type / GC-SSMH type

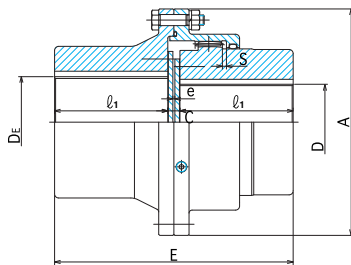

GC-SEM type / GC-SEM type

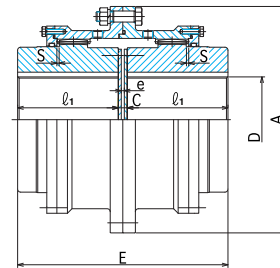

GC-CCM type / GC-CCMH type

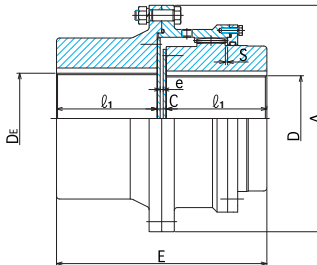

GC-CEM type / GC-CEMH type

Size No.	Shaft dia. (mm)		Dimensions (mm)				
	Max/Min D	Max/Min DE	E	l ₁	C	S	e
112	40/ 17	50/ 17	108	50	8	2	1
125	50/ 22	56/ 22	134	63	8	2.5	1
140	56/ 22	63/ 22	150	71	8	2.5	1
160	65/ 22	75/ 22	170	80	10	3	1
180	75/ 32	80/ 32	190	90	10	3	1
200	85/ 32	95/ 32	210	100	10	3	1
224	100/ 42	105/ 42	236	112	12	4	2
250	115/ 42	125/ 42	262	125	12	4	2
280	135/ 42	150/ 42	294	140	14	4.5	2
315	160/100	180/100	356	170	16	5.5	4
355	180/125	200/125	396	190	16	5.5	4
400	200/140	236/140	418	200	18	6.5	6

Size No.	Shaft dia. (mm)		Dimensions (mm)				
	Max/Min D	Max/Min DE	E	l ₁	C	S	e
450	205/140	225/140	418	200	18	5	6
500	250/170	270/170	494	236	22	6	6
560	280/190	305/190	552	265	22	6.5	6
630	325/224	355/224	658	315	28	8	12
710	360/250	400/250	738	355	28	8.5	12
800	405/280	450/280	832	400	32	9.5	12
900	475/315	510/315	932	450	32	10.5	12
1000	510/355	570/355	1040	500	40	12	13
1120	600/400	640/400	1160	560	40	13	13
1250	710/500	800/500	1460	710	40	14	13
1400	800/560	900/560	1650	800	50	16.5	23
1600	900/630	1000/630	1850	900	50	18	23

Note: 1. The dimensions concerning the main body, such as E and l₁, are identical to those in standard type. Please note, however, less allowance is given for eccentricity and deflection angle than standard type because of the reduced dimension e.

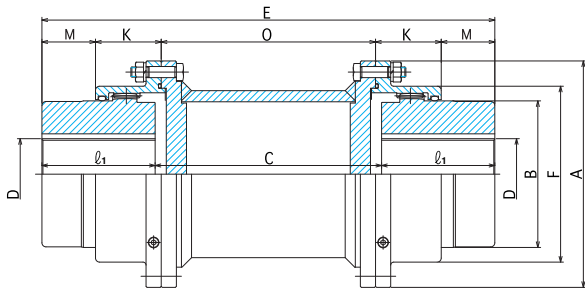

GC-SAM type / GC-SAMH type

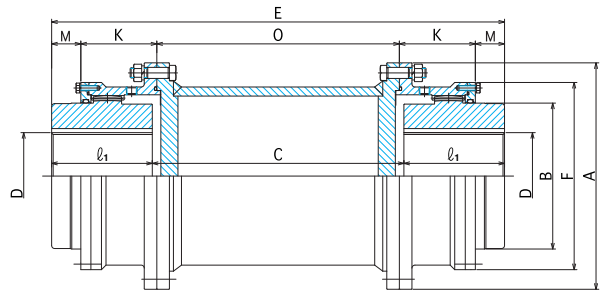

GC-CAM type / GC-CAMH type

Size No.	Shaft dia. (mm)	Dimensions (mm)								
O.D. (mm) A	Max/Min D	l_1	B	F	K	M	E	C	O	
100	32/ 17	45	46	67	34	15				To be discussed.
112	40/ 17	50	58	79	40	14				
125	50/ 22	63	70	92	43	24				
140	56/ 22	71	80	107	47	28				
160	65/ 22	80	95	120	52	33				
180	75/ 32	90	105	134	56	39				
200	85/ 32	100	120	149	61	44				
224	100/ 42	112	145	174	65	53				
250	115/ 42	125	165	200	74	57				
280	135/ 42	140	190	224	82	65				
315	160/100	170	225	260	98	80				
355	180/125	190	250	288	108	90				
400	200/140	200	285	329	114	95				

Size No.	Shaft dia. (mm)	Dimensions (mm)								
O.D. (mm) A	Max/Min D	l_1	B	F	K	M	E	C	O	
450	205/140	200	290	372	151	58				To be discussed.
500	250/170	236	335	424	168	79				
560	280/190	265	385	472	187	89				
630	325/224	315	455	544	213	116				
710	360/250	355	510	622	242	127				
800	405/280	400	570	690	267	149				
900	475/315	450	670	792	295	171				
1000	510/355	500	720	858	322	198				
1120	600/400	560	840	990	360	220				
1250	710/500	710	960	1126	399	331				
1400	800/560	800	1070	1255	449	376				
1600	900/630	900	1260	1450	503	422				

Safety precautions

Before starting to use the product, please read the supplied instruction manual carefully and understand the contents completely. Make sure you have full knowledge about equipment, safety information and precautions prior to use.

In this manual, safety precautions are given as "Warning" and "Caution".



This notation alerts you to the potential danger of serious injury or death in the case of mishandling.

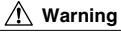

This notation alerts you to the potential danger of bodily harm or damage to properties in the case of mishandling.

Even the precautions given under  if not obeyed, can bring about serious consequences depending on the situation. Make sure to follow the precautions that are all important for your safety.

1. On specifications



- * Never attempt to modify the product. Otherwise the risk of damage or injury may result.
- * Never use the product in explosive atmosphere. Otherwise the risk of explosion, fire or bodily harm may result.



- * Never use the product in the application beyond product specifications. Otherwise the risk of damage or injury may result.

2. In general



- * Only the qualified personnel with expertise and ability should be allowed to carry out such tasks as transportation, unpacking, grounding, piping, wiring, operations, maintenance and inspection. Otherwise the risk of electric shock, fire, damage or injury may result.



- * Never put your fingers or any other substances into the product's opening. Otherwise the risk of electric shock, fire, damage or injury may result.

Requests to customers (exemption from liability)

Further considerations may be required in the following cases: applications over maximum shaft diameters and allowable maximum speed; excessive load fluctuations; repeated impacts; very low running speeds for cranes and the like; reversing units with the turning angles of less than 360 degrees. You are requested to meet with our engineering staff for your best selection. If you purchase our products and use them under out-of-spec running conditions, we are not responsible for machine troubles, accidents and other damages that occur in such unspecified conditions.

* The design and specifications in this catalog are subject to change for product improvements without notice.

MEMO:

**GEAR—COUPLING
INFORMATION SHEET**

Job No. _____ Date _____
 Estimate No. _____ By _____
 Inquiry No. _____
 Revision _____ Date _____ By _____
 Submitted By _____

Applicable To: Proposal Purchase As Built

Customer: _____	Customer's Spec. No. _____
For: _____	No. Required _____
Site: _____	Place of Delivery _____
Model No. _____	Delivery Time _____

Coupling Type:

- Standard Type (Close Coupled)
- Spacer Type (Spacer's Length _____ mm)
- Shear—Pin Type (Shear Torque _____ Nm)
- Brakewheel Type (Dia. ϕ _____ mm * Width _____ mm)
- Slide Type (Sliding Distance _____ mm)

Rating Requirements:

Driven Equipment _____

Driven Equip. Power Normal _____ Max _____

Driver Type _____

Driver Power Rated _____ Max _____

Coupling Rated Power / Speed _____ / _____ rpm

Torque @Max Cont. Speed _____ Nm

Max Torque _____ Nm@ _____ rpm

Frash Max Torque & Cycle _____ %

Existence Heavy Shock Yes _____ % No _____

External Loads _____

Operate Time / Day _____

Direction of Rotation Unidirectional Reversing

Duty Cycle Continuous Intermittent

Other Operating Conditions _____

Coupling Service Factor _____

Offset / Angular Misalignment _____ mm / _____ Deg.

Direction of Installation Horizontal Mounted Vertical Mounted Inclination Mounted

Bore Sizes & Shaft dimensoins:

	Drive Side	Driven Side
Shaft End:	<input type="radio"/> Cylindrical <input type="radio"/> Taper <input type="radio"/> 1—Key <input type="radio"/> 2—Key <input type="radio"/> Hydraulic Taper	<input type="radio"/> Cylindrical <input type="radio"/> Taper <input type="radio"/> 1—Key <input type="radio"/> 2—Key <input type="radio"/> Hydraulic Taper
Bore Requirements:		
Bore Condition	<input type="radio"/> Finish <input type="radio"/> Rough Stock Bore	<input type="radio"/> Finish <input type="radio"/> Rough Stock Bore
Dia. / Tolerance	_____	_____
Max Interference Fit	_____	_____
Length	_____	_____
Keyway Dimens. / Tolera.	_____	_____
Chanfering Dimens.	_____	_____
Distance Between Shaft End or Shaft Gap	_____	_____

Installation Date

- Indoor Heated Under Roof
- Outdoor Unheated Partical Sides
- Grade Mezzanine _____
- Winterization Req'd Tropicalization Req'd
- Electrical Area: Class _____ Grp _____ Div _____
- Elevation _____ m Barometer _____ kPa abs
- Ambient Temperatures: Normal _____ °C Max _____ °C Min _____ °C
- Unusual Condition Dust Fumes _____

Sketch Area

Design Requirement: Balance Class _____ Weight _____ WR² _____ Stiffness _____

Lubrication: Oil Grease Oil—Bath Forthed lub.

Spare: _____

Attachment: _____

Competitive Data: Make _____ Size & Type _____
 Bores _____ & _____ Price _____

Additional Comments: _____

Global Net-Work

Please contact your local international sales office for detail information. The Global Net-Work of Sumitomo Heavy Industries is at your service for Seisa gears and other products.

