

WASTE WATER & SLUDGE TREATMENT

INQUIP
BULK MATERIAL
& DUST HANDLING

PRODUCT » DENSITY » FLOW

Distributor for  WAMGROUP

Rotary Drum Screens WASTEMASTER® FTR



 WAMGROUP®

 SPECOR®

DE-WATERING, CONVEYING AND COMPACTING ALL IN ONE

WASTEMASTER® FTR is a rotating drum screen designed to combine the separation of solids present in the effluents with compacting and de-watering of the screenings so obtained. It consists of a rotating drum screen basket, a conveyor screw (with SINT™ self-cleaning drainage liner) and, as an option, a compacting module.

WASTEMASTER® FTR is a space-saving machine that combines multiple functions in one machine only: screenings separation, drainage, conveying and de-watering.

Depending on the screen size of the drum and screen mesh dimensions, a flow rate of up to 2,000 litres per second can be obtained.

Technical Features

- Fabricated parts entirely manufactured from 304 L / 316 L SS
- Shaftless conveyor screw manufactured from 304 / 316 SS or special high resistance steel
- Perforated or wedge wire drum screen in various mesh sizes
- Versatile unit for concrete channel installation
- No outlet end bearing, no intermediate bearings
- Solids extraction of up to 15 m³/h
- Self-supporting drum and extracting screw
- Single drive unit



Rotary drum with cleaning nozzles



Single drive unit for drum and conveyor screw



SINT™ Self Cleaning Drainage

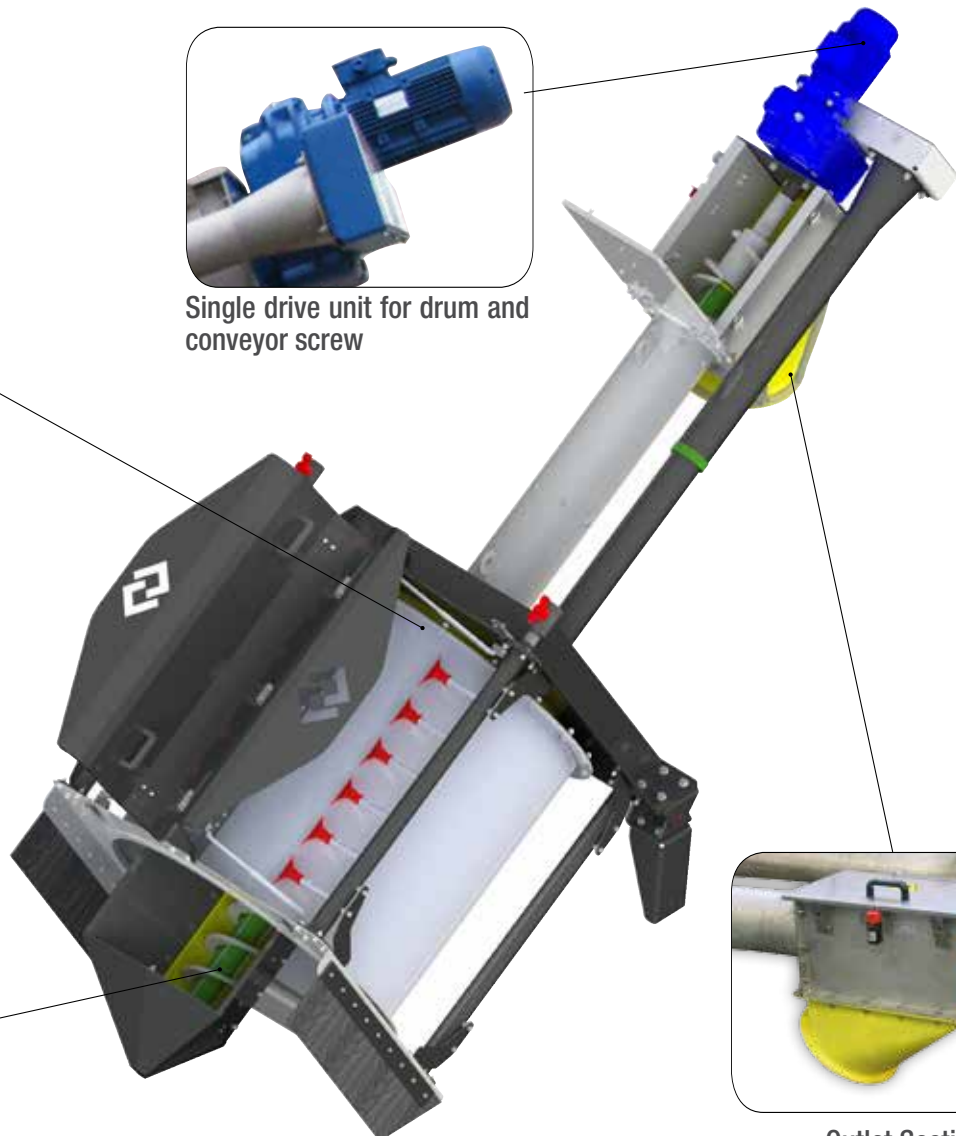

Outlet Section

Benefits

- ✓ High flow rates;
- ✓ Obstacle-free inlet;
- ✓ SINT™ liner and jagged screw flighting for high removal rate with difficult materials such as fibres;
- ✓ Single drive unit with a low energy consumption.

Overall Dimensions

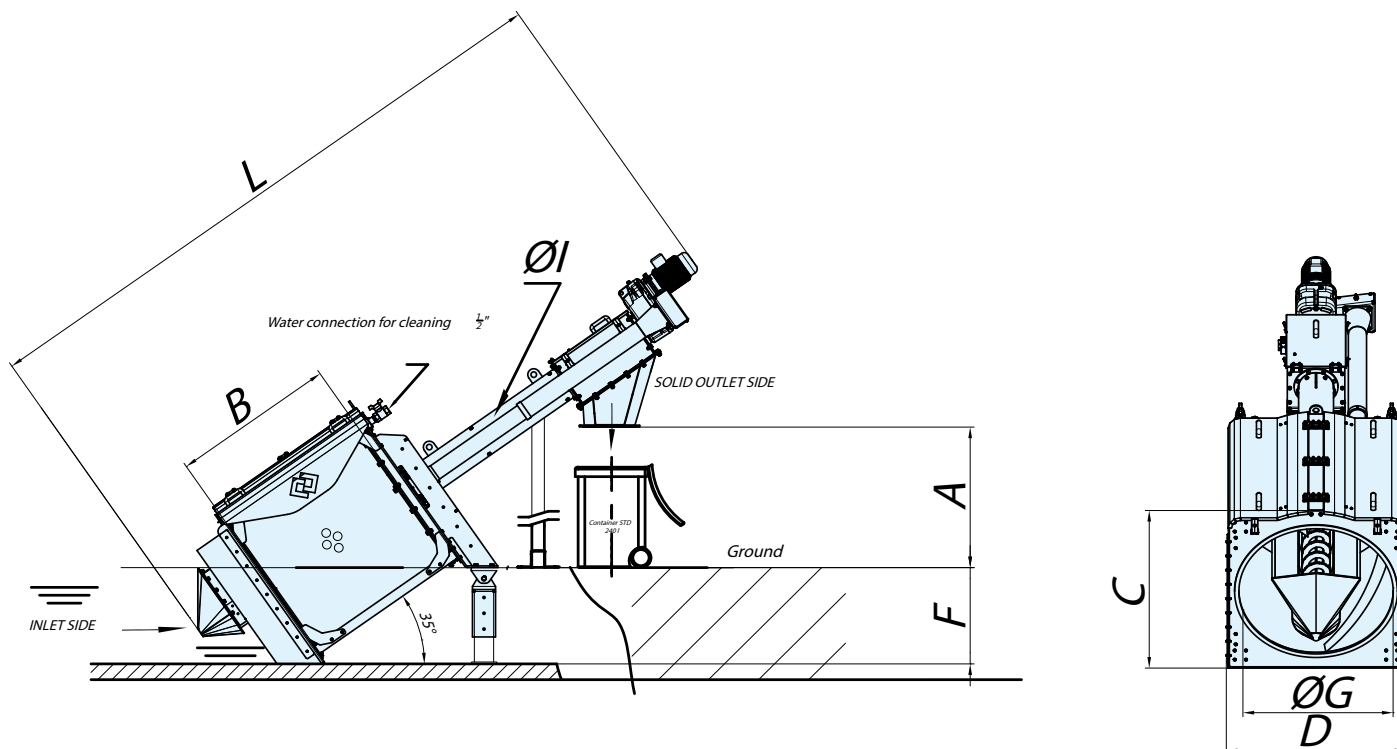

Size	A	B	C	D	F	ØG	ØI	L
800	1,500	800	1,000	900	600	800	219	5,000
1000	1,500	1,000	1,200	1,100	800	1,000	219	5,300
1200	1,500	1,200	1,400	1,300	1,000	1,200	323	5,600
1400	1,500	1,400	1,600	1,500	1,200	1,400	323	6,000
1600	1,500	1,600	1,800	1,700	1,300	1,600	323	6,200
1800	1,500	1,800	2,000	1,900	1,500	1,800	406	6,500
2000	1,500	2,000	2,200	2,100	1,700	2,000	406	7,000

Dimensions in mm

Accessories

- Bag-clamping system
- Collar
- Endless tube

Application



063002389 May 2015 Rights reserved to modify technical specifications.

