

KBMD-240D

MULTI-DRIVE™

Variable Speed DC Motor Control
For Shunt Wound and PM Motors
Patented Overload Circuit

1/100 – 1 Hp @ 115 VAC – 50/60 Hz[▲]
1/50 – 2 Hp @ 230 VAC – 50/60 Hz[▲]

TYPICAL APPLICATIONS

- Conveyors • Packaging Machines
- Feeders • Printing Equipment



STANDARD FEATURES

- Plug-in Horsepower Resistor^{®▲}. Allows a single model to be used on a wide range of motors.
- Dual Voltage Switch. Used to select AC line voltage operation of 115 or 230V.
- Built-in AC Line Fuse
- MOV Transient Protection (20 JOULE)
- Trimpots: MIN, MAX, IR, CL, ACCEL, DECEL
- ▲ PHR Supplied Separately

OPTIONAL FEATURES

- Auxiliary Heatsink (P/N SC-9861). Extends control rating to 1 Hp at 115V and 2 Hp at 230V.
- Forward-Brake-Reverse Switch (P/N SC-9860). Includes switch and prewired dynamic brake resistor.

SPECIFICATIONS

Speed Range (Ratio)	50:1
Load Regulation (0 – Full Load, 50:1 Speed Range) (% Base Speed)	1*
Line Voltage Regulation (At Full Load, ± 15% Line Variation) (% Base Speed)	1/2*
Control Linearity (% Speed vs. Dial Rotation)	2
CL/Torque Range (% Full Load)	0 – 200
ACCEL/DECEL Time (Secs.)2 – 10
MIN Speed Trimpot Range (% Full Speed)	0 – 30*
MAX Speed Trimpot Range (% Full Speed)	50 – 120*
Maximum Allowable Ambient Temperature (At Full Rating, °C/°F)	40/105

▲ Rating indicated is with Auxiliary Heatsink. Maximum rating without Auxiliary Heatsink is 1/2 Hp at 115V and 1 Hp at 230V.
* Performance is for 90V PM motors on 115 VAC and 180V PM motors on 230 VAC.

DESCRIPTION

Multi-Drive™ represents the latest in state-of-the-art design for variable speed DC motor controls. It is rugged and compact in size and is able to handle both 115 and 230V AC line inputs by setting the built-in Dual Voltage Switch. In addition, the single model can be used on a wide range of motors by selecting and inserting the appropriate Plug-in Horsepower Resistor[®].

The standard model, KBMD-240D, controls all motors through ¼ Hp at 115V and 1½ Hp at 230V. By installing the KB Auxiliary Heatsink, the horsepower range is increased to 1 Hp at 115V and 2 Hp at 230V. The versatility of the control is enhanced with the optional Forward-Brake-Reverse Switch Kit.

The electronics for the Multi-Drive™ consists of KB's patented KBMM™ speed control module. Its field-proven reliability is confirmed by over 100,000 controls presently in operation. The KBMM™ module is housed in a rugged metal (not plastic, like other inexpensive drives) enclosure. Keyhole slots facilitate mounting while a readily accessible terminal block simplifies wiring. Included with each control is a detailed instruction and user manual.

WIRING DIAGRAM

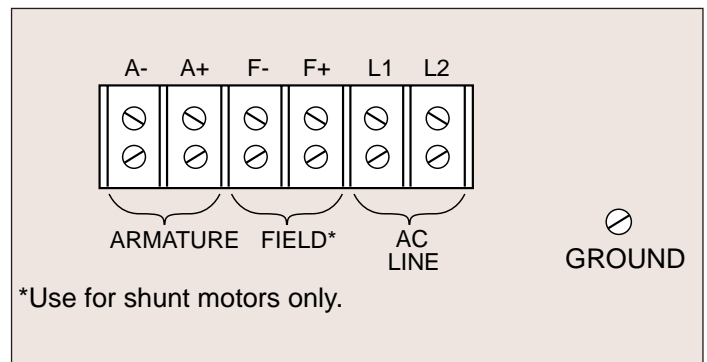

* CE Compliance Requires KBRF-200A RFI Filter



FEATURES & FUNCTIONS

- (1) Rugged all aluminum enclosure
- (2) Keyhole slots facilitate mounting
- (3) AC Power Indicator
- (4) ON/OFF Power Switch
- (5) Speed Control Knob
- (6) Auxiliary Heatsink (optional)
- (7) FWD-BRK-REV Switch (optional)
- (8) Dual Voltage Switch ("115" or "230")
- (9) AC Line Fuse Included
- (10) Plug-in Horsepower Resistor®
- (11) Barrier Terminal Block
- (12) Internal adjustments for MAX, MIN, IR, CL, ACCEL and DECEL (not shown)
- (13) CL LED Indicator
- (14) Armature Fuse (customer supplied)

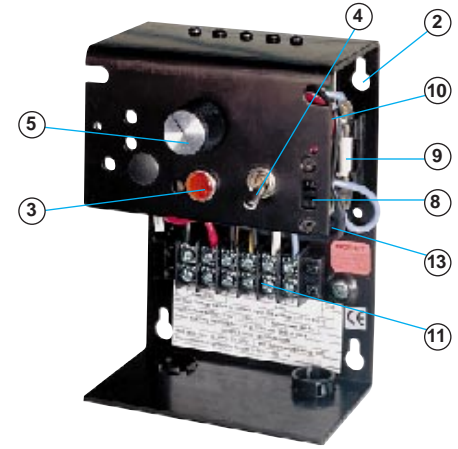

ELECTRICAL RATINGS

Model Number	KB Part Number	AC Line Voltage (VAC) ± 15% (50/60 Hz)	Motor Voltage (VDC)	Rating Without Auxiliary Heatsink			Rating With Auxiliary Heatsink		
				Max. AC Load Current (RMS Amps)	Max. DC Load Current (Avg. Amps)	Maximum Horsepower [Hp, (KW)]	Max. AC Load Current (RMS Amps)	Max. DC Load Current (Avg. Amps)	Maximum Horsepower [Hp, (KW)]
KBMD-240D	9370	115	90 - 130	12.0	8.0	0.75, (0.6)	16.0	11.0	1, (.75)
		230	180	12.0	8.0	1.5, (1.1)	16.0	11.0	2, (1.5)

The Multi-Drive™ can be converted to the higher rating by installing KB's Auxiliary Heatsink.

The Multi-Drive™ must be set for either 115V or 230 VAC line voltage input by setting the Dual Voltage Switch to "115" or "230". When the control is set for "115", use only 90 – 130 VDC rated motors. When the control is set for "230", use 180 VDC rated motors.

Field Voltage is 100 VDC with 115 AC line input, and 200 VDC with 230 AC line input.

MECHANICAL SPECIFICATIONS

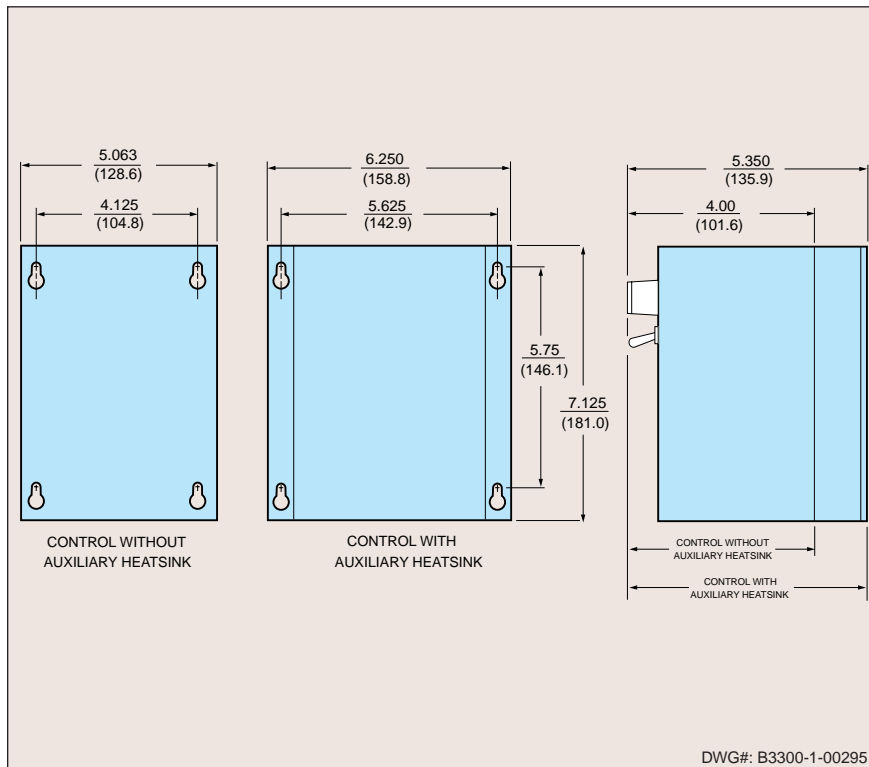

PLUG-IN HORSEPOWER RESISTOR® CHART

Motor Horsepower Range**		Plug-in-Horsepower Resistor® Resistance Value (ohms)
Armature Voltage 90 – 130 VDC	Armature Voltage 180 VDC	
1/100 – 1/50	1/50 – 1/25	1.0
1/50 – 1/30	1/25 – 1/15	.51
1/30 – 1/20	1/15 – 1/10	.35
1/20 – 1/12	1/10 – 1/6	.25
1/12 – 1/8	1/6 – 1/4	.18
1/8 – 1/5	1/4 – 1/3	.1
1/4	1/2	.05
1/3	3/4	.035
1/2	1	.025
3/4*	1½*	.015
1*	2*	.01

* Must be used with Auxiliary Heatsink.

** For overlapping motor horsepower range use lower value Plug-in Horsepower Resistor®.

© 1998 KB Electronics, Inc.

WA HEAD OFFICE

Unit 1 / 45 Inspiration Drive WA 6065
 (08) 9303 4966 (08) 9303 4977
 info@chainanddrives.com.au

NSW HEAD OFFICE

Unit 7 / 70 Holbeche Road Arndell Park NSW 2148
 (02) 9674 8611 (02) 9674 8363
 salesnsw@chainanddrives.com.au

www.chainanddrives.com.au