

# IndraDrive ML

## Large electric drives up to 4 MW

Efficient | universal | intelligent



**i4.0**  
CONNECTED  
INDUSTRY

**OPEN CORE  
ENGINEERING**

**SAFETY  
ON  
BOARD**

**4EE**  
ENERGY  
EFFICIENCY



## IndraDrive ML: Electric drive technology for powers in the megawatt range

Now more than ever before, machine users are focusing on productivity and costs, sales growth generated by new products and markets, and safeguarding future competitiveness by reducing response times. The machines used and the drive technologies they employ must therefore maintain a high level of availability, energy efficiency, and maximum flexibility in production. The new large electric drives from the Rexroth IndraDrive family offer flexible solutions with intelligent functions for powerful drive solutions that extend into the megawatt range.

Application-specific, modular machines are the key objective, and optimized drive technologies are the way to achieve it. Electric solutions can provide a valuable alternative to other technologies, especially when high power outputs are required. Investment decisions for the suitable, under circumstances more economic technology, should be balanced as best as possible.

To this end, machine and automation systems manufacturers are continually being asked to come up with alternative concepts. Application-specific and preprogrammed drive solutions are needed to minimize engineering outlay and facilitate potential adaptations within the application itself. An in-depth understanding of the industry and application know-how are also beneficial in contributing to a wide variety of drive engineering tasks, including those that are highly complex and sophisticated.

Rexroth is the only automation specialist in the market that fulfills a complete range of hydraulic, electric, and hybrid drive solutions (e.g. variable-speed pump drives) extending into the megawatt range from a single source. Profit from our vast industry and application know-how – from metal forming to marine and offshore applications, as well as applications in many other sectors in which large electric drives from Rexroth offer new possibilities for innovative machine concepts.

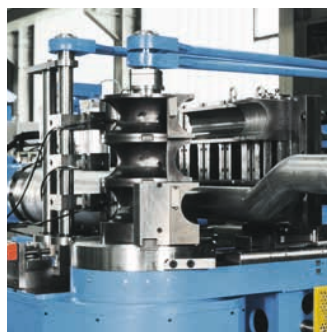

- ▶ Metal forming: Presses, bending machines
- ▶ Metallurgy: Rolling mill technology
- ▶ Plastics processing technology: Extruders, injection molding machines
- ▶ Marine and offshore: Trawler and anchor winches, ship cranes
- ▶ Materials handling equipment: Container cranes, conveyor belts
- ▶ Test rig equipment: Transmission and engine/motor test stands, test rigs for hydraulics
- ▶ Print and paper: Flexo printing, winders, cross-cutters, central dc supply
- ▶ Civil engineering: Lift bridges, hydropower generators



# Megawatt universal power inverters

The new IndraDrive ML units extend the IndraDrive family to include the higher output range, by which individual units are capable of generating up to 500 kW. Up to 8 units can be connected in parallel to reach outputs as high as 4 MW. These space-saving, modular inverters are therefore somewhat of an all-rounder and can be used as mains or motor inverters to minimize the number of variants, simplify handling and reduce storage costs.



## Technical key data

- ▶ Individual unit outputs of 110 kW to 500 kW in up to 8 graduated increments
- ▶ System outputs of up to 4 MW via parallel connection
- ▶ Mains voltage: 3 AC 380 - 500 V or 525 - 690 V / 50 - 60 Hz / TN, TT and IT networks
- ▶ Types of cooling: Liquid cooling, air cooling
- ▶ 1.5 x overload for 60 seconds

## Efficient, universal, intelligent

The modular universal power inverters are predestined for all types of multi-axis applications as they are powerful and versatile drives that can be used in the megawatt range. Universally deployable for standard and servo implementations, with comprehensive additional options to align on-demand output with a wide variety of applications. The inverters also incorporate all the aspects that the IndraDrive family is known for, from certified safety technology, to drive-integrated motion logic solutions, through to multi-encoder interfaces and multi-Ethernet communication.

## Advantages resulting from special product features

- ▶ Modular universal power inverters for multi-axis applications: Minimize variant diversity, simplify handling, and reduce storage costs
- ▶ Application-specific concepts for saving energy: Adaptable to any application, they not only save energy, but also reduce line loads
- ▶ High power density: The compact design minimizes the installation space required in the control cabinet
- ▶ Low coolant quantities at high operating temperatures: Enable compact heat exchangers and efficient heat recovery
- ▶ Wide application range due to numerous certifications for industrial applications pursuant to CE, UL, CSA as well as type approved in typical marine applications according to the ship classification authorities DNV GL, ABS and LR



### Optimal device topology

For reducing storage costs via a scaled hardware concept

- ▶ Universal power inverter can be used as a motor inverter or a mains inverter with energy-recovery function
- ▶ Optimally graduated power range from 110 kW to 500 kW
- ▶ Parallel connection to boost output capacity up to 4 MW
- ▶ Wide voltage range of 380 - 500 V and 525 - 690 V
- ▶ High pulse width modulation frequency (PWM) for optimal utilization of the motor
- ▶ Low harmonic emissions for good compatibility with the network
- ▶ Regulated DC bus voltage – independent of the mains voltage and resistant to fluctuations in voltage

### Alternative cooling concepts

From basic dissipation of heat loss to active utilization in heat-recovery systems

- ▶ Air cooling
- ▶ Air cooling with separate air duct
- ▶ Liquid cooling

### Application-optimized energy concepts

The optimal function for lowering consumption and reducing peak loads that are taken into account in almost every application

- ▶ Energy regeneration into the power grid
- ▶ Distribution of drive energy via DC links

- ▶ Kinetic buffering with rotating energy storage
- ▶ Electric buffering with static energy storage
- ▶ Smart Energy Mode for soft mains regeneration
- ▶ Regulation of reactive current for reducing power loss in the power supply

### Performance control units with intelligent firmware

- ▶ Scalable performance
  - BASIC – Basic and standard servo applications
  - ADVANCED – High-end servo applications
- ▶ Multi-Ethernet and multi-encoder interface
- ▶ Interface options for fieldbus, I/O, etc.
- ▶ Firmware options as expansion package

### Integrated control functions

- ▶ Motion logic drive-integrated (IndraMotion MLD)
  - IndraMotion MLD-S single-axis control
  - IndraMotion MLD-M multi-axis control
- ▶ Application-specific, predefined technology functions
- ▶ Productivity Agent for preventative maintenance
- ▶ IEC 61131-3-compliant programming

### Certified safety technology

- ▶ Drive-integrated safety systems to protect man, machine, and tooling
- ▶ Certified according to EN ISO 13849-1 and EN 62061
- ▶ Safe Torque Off for safe interruption of applied torque
- ▶ Safe Motion for safe movements

# Optimal device topology for a broad area of applications

The universal power inverters in the IndraDrive ML modular system can be used as motor inverters to operate synchronous and asynchronous motors or as mains inverters with energy-recovery capacity. This not only reduces inventory, but also system complexity. The drive series offers a good balance of incremental power outputs. The wide voltage range facilitates applications in many different industries and regions.

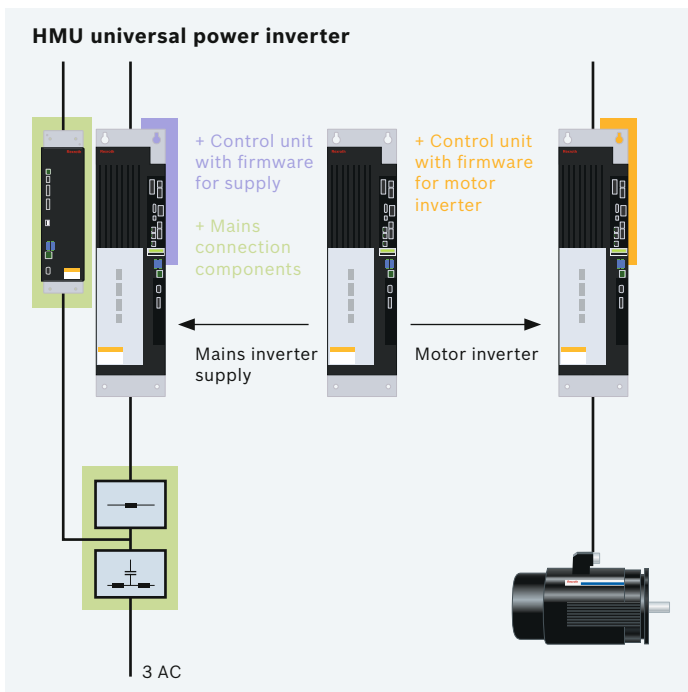

## Universal power inverter as a shared power output basis

Large electric drives from Rexroth can either be used as motor inverters or mains inverters with regenerative power capacity (supply unit); the control unit is what defines the operative function. This reduces variant diversity and storage costs.

## Power electronics for ultra-high demands

Configured as a mains inverter with regenerative power capacity, the active inverter keeps mains feedback to a minimum while the regulated DC bus voltage ensures independence from the supply voltage across a wide range of 380 V to 500 V or 525 V to 690 V as well as a high level of tolerance for balancing out fluctuations in voltage. Cycling with high PWM ensures that the motors are optimally used and noise emissions are kept as low as possible.

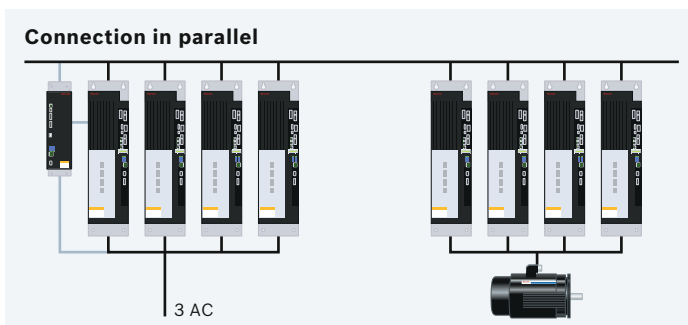

## Parallel connection for ultra-high output in optimal increments

Large electric drives from Rexroth offer individual power outputs of 110 kW to 500 kW in up to 8 graduated increments and a combined system output of 4 MW where as many as 8 units are operated in parallel. Output can also be fine tuned to the requirements of the application at hand during parallel operation, including at the highest level of output for supply unit and inverter configurations.

# Alternative cooling concepts for maximum energy efficiency



IndraDrive ML units can be cooled by air or liquid, and, as required, there are different options available for dissipating and utilizing heat.

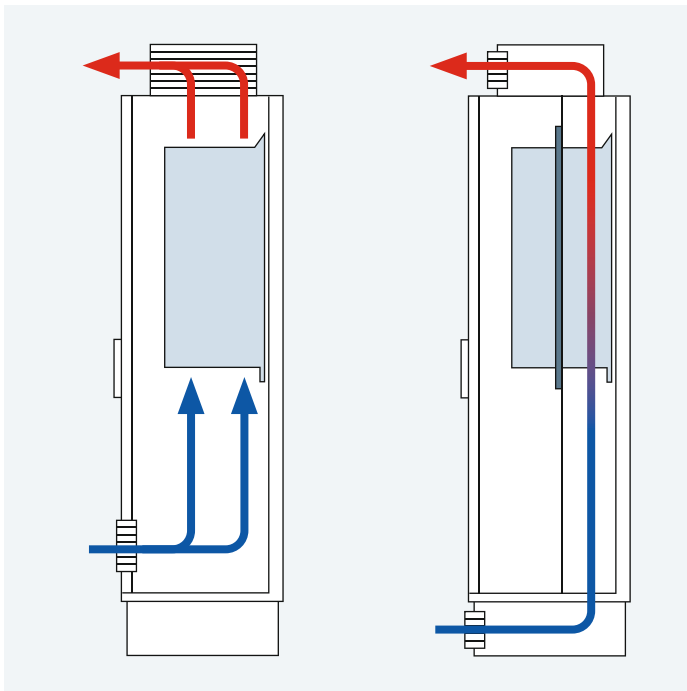

## Air cooling

Installed in the control cabinet, the air-cooling design is the most cost-effective variant for dissipating heat loss at low output levels. To reduce energy and noise levels, air-cooled IndraDrive ML variants are fitted with fan assemblies that operate based on load. Air cooling via a separate air duct allows the control cabinet to achieve a higher rated protection class, while targeted heat dissipation through an air ducting system is simplified outside the cabinet.

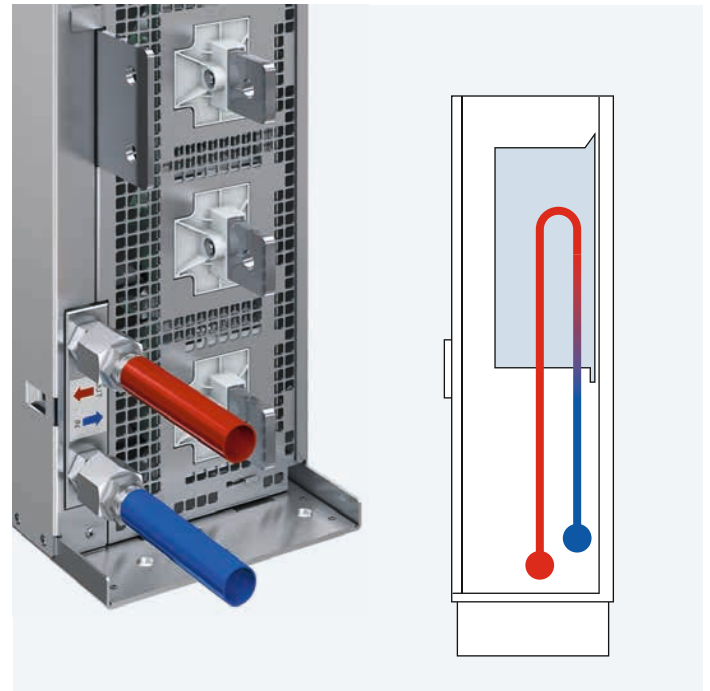

## Liquid cooling

Liquid cooling is the most efficient method of dissipating heat, or channeling heat loss. The high inflow temperature of the coolant enables energy to be used effectively in heat-recovery systems. Noise levels are also reduced to a minimum. Control cabinets that have a high rated protection type are easy to accomplish.

# Application-specific concepts for energy-efficient production



Designed to meet the requirements of the target application, the IndraDrive ML always offers the best possible solution for plant operation in an energy-efficient manner. A wide variety of concepts for storing energy in static or rotary configurations as well as a Smart Energy Mode and further options are available for saving energy and reducing peak loads in the power grid.

## Mains regenerative power

Feeding surplus energy back into the power grid considerably reduces consumption, especially during generator operation over an extended period. This, in turn, leads to a high power quality with almost zero harmonic emissions. Regulated DC bus voltage ensures maximum independence from the supply voltage as well as a high level of tolerance for balancing out fluctuations in the voltage.

## Smart Energy Mode

Actively regulating the mains inverter in smart energy mode ensures a reliable supply of DC bus voltage that is independent from the mains voltage while utilizing the DC link capacitors for energy storage. The benefits offered by this are particularly apparent when generator and motor power modes are frequently switched as is the case with intermittent acceleration and braking cycles. Peak loads on the line side are also avoided, and average energy consumption

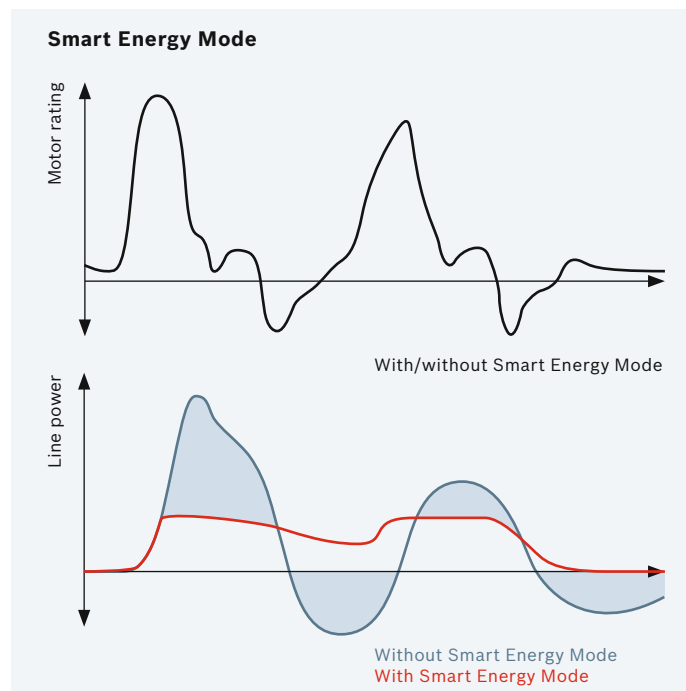



is reduced. This improves network compatibility and allows smaller components to be used without compromising machine performance.

### Electric and kinetic buffering

Two possibilities exist for buffering large amounts of energy:

- ▶ **Electric buffering:** With electric buffering, large DC-bus capacitor units can be charged to conveniently buffer as much as 700 kJ of energy.
- ▶ **Kinetic buffering:** Kinetic buffering is the process of converting surplus energy into kinetic energy and storing it in a buffer device. By optimizing this energy for the respective production process, the energy supply can be made available to the system on demand and as required thanks to a host of configurable functions.

### DC links

A modular filter concept allows the IndraDrive ML to connect several drives via the DC bus so that energy can be exchanged in multi-axis systems. Central energy storage devices can also be used together.

### Regulation of reactive current

Regulating reactive current eliminates the losses produced by the current in the mains connection configuration. Inductive or capacitive consumers can likewise be compensated without the need for additional reactive current compensation systems.

### Intelligent energy management at a glance

- ▶ Lower average energy consumption
- ▶ Reduction in peak grid loads
- ▶ Reduction in power loss in the control cabinet
- ▶ Reduced control cabinet space required thanks to smaller power supply components
- ▶ Minimal outlay expended to cool the control cabinet

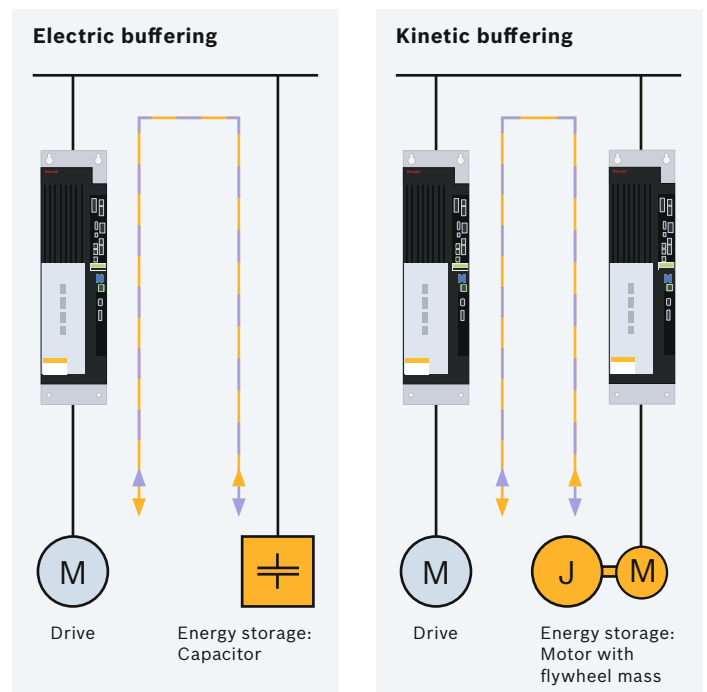

### Regulation of reactive current

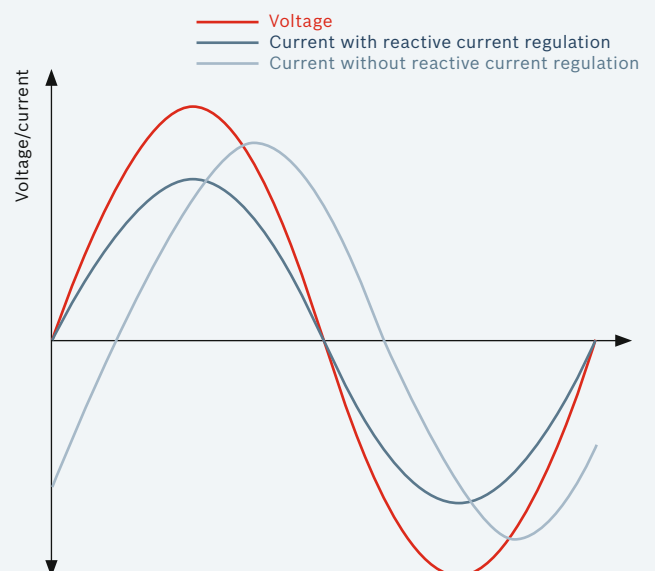

# Control units: Scalable performance and functions

Scalable control units and application-specific firmware options allow IndraDrive ML from Rexroth to cover a wide range of standard applications up to and including high-end servo applications that require a high level of dynamic response and precision. We can supply the control unit you need for the application scenario you have in mind. Standardized interfaces, comprehensive firmware functions, integrated motion logic, a host of technology functions, and certified safety technology leave nothing to be desired.

## BASIC control unit



## ADVANCED control section



### BASIC control units – the scalable standard

These units constitute the economic solution for all applications involving standard requirements in terms of control quality and interface flexibility. The BASIC control unit includes a multi-Ethernet, a multi-encoder, and an optional safety technology interface. Two additional interface options allow additional fieldbuses, encoders, or analog/digital I/O extensions to be integrated.

### ADVANCED control units – for maximum freedom and performance

These units meet the highest requirements in terms of performance, and a high level of computing power greatly reduces cycle times. Customers can also integrate a Sercos master to serve as a basis for a drive-integrated control system in addition to the options afforded by a BASIC control unit.

### Multi-protocol capable hardware

The protocol used for Ethernet-based interfaces is selected in a software application. Available protocols include Sercos, PROFINET IO, EtherNet/IP, POWERLINK and EtherCat. PROFIBUS and CANopen can also be chosen as optional interfaces.

### Multi-encoders

The control units provide base support for all commonly used encoder types thanks to their built-in multi-encoder interface. This gives you maximum freedom in choosing your encoder and motor system.

### Communications interface

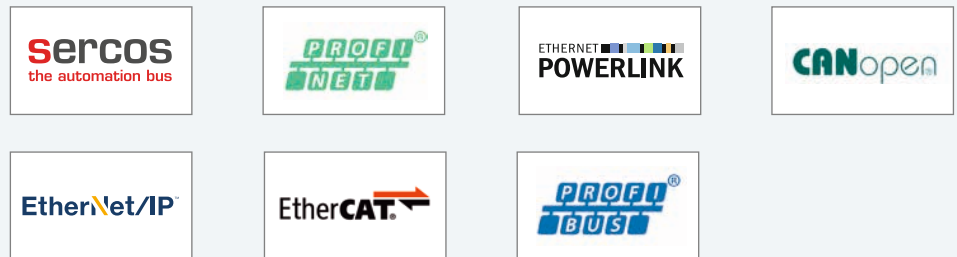

### Flexible firmware configuration

Optimally adapted BASIC and ADVANCED firmware variants are available for the control unit hardware. This firmware can be configured in line with the requirements of your applications:

- ▶ Basic packages
  - OPEN LOOP (frequency converter applications)
  - CLOSED LOOP (servo and frequency converter applications)
- ▶ Extension packages (option)
- ▶ Motion logic (IndraMotion MLD, option)

The basic package is already adequate to perform the majority of standard drive functions, from simple V/f control right through to positioning block mode. Various extension packages provide you with the options of electronic synchronization, additional servo functions or main spindle operation. The freely programmable motion logic with integrated PLC conforming to IEC 61131-3 requirements and ready-to-use technology functions facilitate simple execution of complex machine processes.

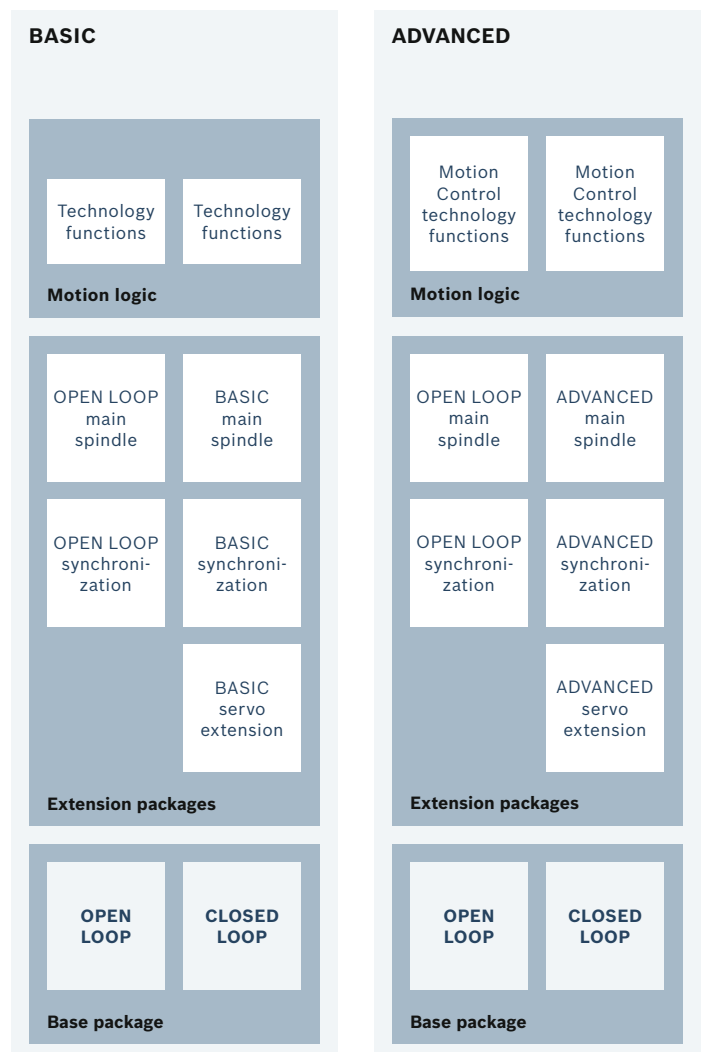

# Control functions: More options for every application

With IndraMotion MLD, the drive-integrated control system from Rexroth, drive functions, motion control, and processing logic merge to form a modern, open automation platform for modular machine concepts. As a result, you can realize applications independently, without higher-level control.

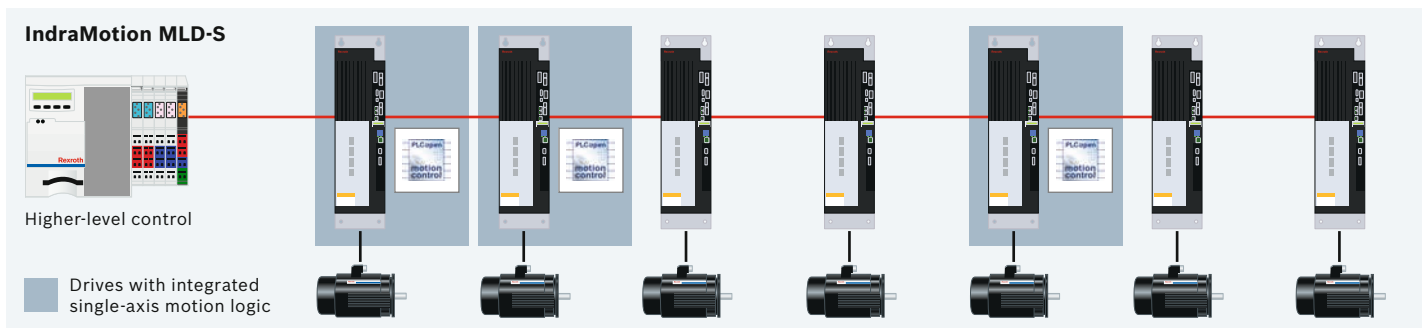

## IndraMotion MLD-S single-axis motion logic

In order to carry out drive engineering tasks that target a specific axis and relieve the load placed on the higher-level control, this system offers the option of moving individual functions to specific drive units. To this end, a wide variety of predefined technology functions can be leveraged, or a separate application can be created as required.

## IndraMotion MLD-M multi-axis motion logic

For applications involving a limited number of axes, a Sercos master drive can be used to coordinate up to 9 additional drives. Motion tasks with greater levels of complexity can also be done at the drive level, without the need to integrate the higher-level control.

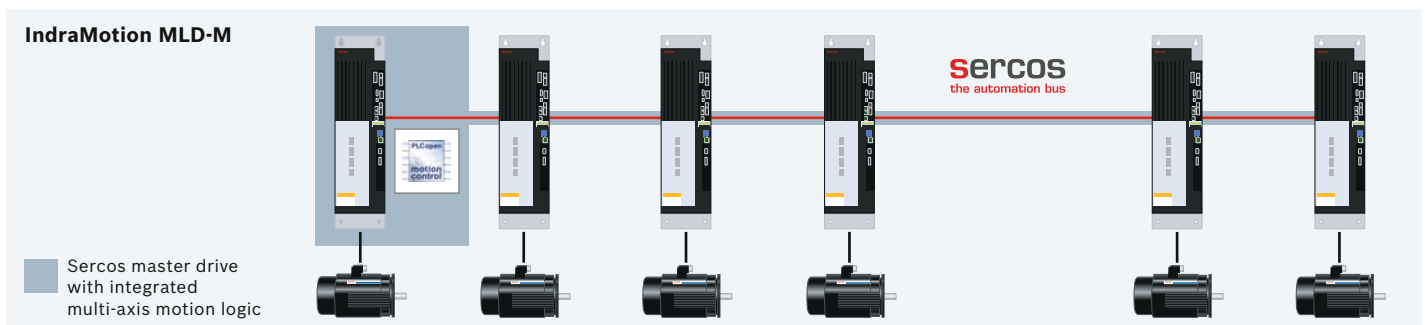



### Open to standards

Standardized programming languages and the IndraWorks universal engineering framework simplify project planning, programming, parameterization, operation, and diagnosis. In the process, they integrate valuable know-how directly in the drive to give users an additional competitive edge. Programming is in conformity with IEC 61131-3 in the following languages:

- ▶ Instruction List (IL)
- ▶ Structured Text (ST)
- ▶ Function Block Diagram (FBD)
- ▶ Ladder Diagram (LD)
- ▶ Sequential Function Chart (SFC)
- ▶ Continuous Function Chart (CFC)

Standardized modules from the function library in conformity with PLCopen give you access to a multitude of motion functions.

### Flexible programming

User-defined programming makes it possible to design applications in a flexible, versatile manner. Innovative drive functions, extensive functions libraries, and process-oriented technology packages combine to form a perfect automation solution.

### Predefined functions

Large-scale and sophisticated applications in particular can also be handled with our ready-to-use, predefined technology functions. These applications can then be added to the individual user program or utilized as configurable functions.

Examples of items included in the range:

- ▶ PLCopen modules
- ▶ Tension control
- ▶ Loop control
- ▶ Winder
- ▶ Demand processing
- ▶ Productivity Agent
- ▶ Extended drive functions
  - Variable retraction motion
  - Adaptive feed rate control
  - Analog force control
  - And much more

### Productivity Agent

The properties and characteristics of machines and plants change during daily operation as a result of contamination, wear, and other influences associated with harsh industrial environments. Using the Productivity Agent helps operators detect these changes in good time so that they can respond quickly and effectively. To this end, the Productivity Agent includes various online and offline monitoring and analysis functions for mechanicals and processes to improve the performance and availability of the machines:

- ▶ Mechanical analysis
- ▶ Outer circle monitoring
- ▶ Vibration damping and avoidance
- ▶ Collision monitoring
- ▶ Frequency response analysis
- ▶ S1 characteristic curve analysis
- ▶ Process controller

# Certified safety: For protecting man, machine, and work pieces

**SAFETY  
ON  
BOARD**

The extremely short response times of the large electric drives from Rexroth are proof of what modern safety technology can do to protect man, machine, and work pieces, as all motions are monitored right where they start. The Safe Torque Off and Safe Motion functions can also be implemented, depending on requirements.





**Safe Torque Off: For safe interruption of applied torque**

The Safe Torque Off (STO) safety function reduces the amount of hardware needed as well as wiring costs. Axes equipped with STO ensure a high level of safety without taking the longer route through the higher-level control system.

When the STO function is activated, the drive responds with-in milliseconds by interrupting the torque and current supply to the motor connected. This, in turn, prevents the motor from starting up again after having come to a stop. The STO function is certified with Cat. 4 PL e in conformance with EN ISO 13849-1 and with SIL 3 in conformance with EN 62061.

**Safe Motion: For safe movements**

The optional Safe Motion safety technology offers a comprehensive list of safety functions that range from Safe Stopping through to Safe Travel Moments.

Functions requiring no encoder, such as SS1, SS1-ES, STO, SBC, and SDL, are certified with Cat. 4 PL e in conformance with EN ISO 13849-1 and with SIL 3 in conformance with EN 62061. Functions requiring encoder feedback, such as SS2, SOS, SLS, SMS, SMD, SLI, and SDI, are certified with Cat. 3 PL d in conformance with EN ISO 13849-1 and with SIL 2 in conformance with EN 62061.

For logging purposes, IndraDrive uses the safety standard CIP Safety. Signals are simply pulsed in along with the standard data of the Sercos network in real time. Integrating drive, peripheral, and safety buses as well as standard Ethernet communication into a single network simplifies handling and reduces hardware and installation costs.

With CIP Safety on Sercos, up to 64 axes can be operated in a safe manner. The signals can also be provided by way of a zone module for selecting the safety functions. This eliminates the need for a higher-level safety controller, and up to 25 axes can be operated safely.

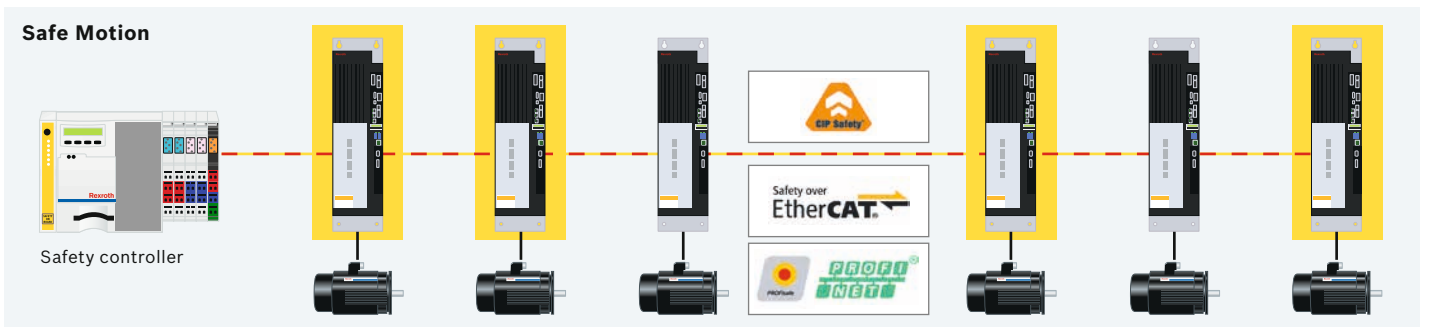

# Technical Data:

## HMU universal power inverter

### 380 - 500 V

Universal power inverter, liquid-cooled		HMU05.1N- F0140-0350- N-A4-D7-__- _NNN	HMU05.1N- F0170-0430- N-A4-D7-__- _NNN	HMU05.1N- F0220-0510- N-A4-D7-__- _NNN	HMU05.1N- F0270-0660- N-A4-D7-__- _NNN	HMU05.1N- F0340-0820- N-A4-D7-P__- _NNN	HMU05.1N- F0430-1040- N-A4-D7-P__- _NNN	HMU05.1N- F0540-1300- N-A4-D7-P__- _NNN	HMU05.1N- F0680-1690- N-A4-D7-P__- _NNN	
<b>Power data as mains inverter</b>		Low degree of overload capacity <sup>1)</sup>   High degree of overload capacity <sup>2)</sup>								
DC bus baseline power	[kW]	144   120	173   144	216   173	270   216	339   270	430   339	535   430	672   535	
DC bus overload power	[kW]	158   180	190   216	238   260	297   324	373   405	473   509	589   645	739   803	
Line input current (baseline power)	[A]	216   180	260   216	324   260	405   324	509   405	645   509	803   645	1,009   803	
DC bus continuous power	[kW]	145	174	219	273	342	435	540	679	
Mains connection voltage	[V]	3 AC 380 to 500 (-15 % / +10 %)								
Supply frequency	[Hz]	50 / 60 (± 2Hz)								
DC bus voltage	[V]	Regulated, configurable 1.5 x U <sub>supply</sub> up to 750 V								
<b>Power data as motor inverter</b>		Low degree of overload capacity <sup>1)</sup>   High degree of overload capacity <sup>2)</sup>								
Typical motor rating <sup>3)</sup>	[kW]	132   110	160   132	200   160	250   200	315   250	400   315	500   400	630 500	
Base-load current	[A]	251   209	303   251	388   303	485   388	610   485	763   610	992   763	1,173 992	
Overload current	[A]	276   314	333   377	427   454	533   582	671   727	839   915	1,091   1,144	1,291   1,488	
Continuous current	[A]	254	306	392	490	616	771	1,002	1,185	
Maximum current	[A]	355	427	515	660	825	1,037	1,297	1,686	
Nominal switching frequency	[kHz]	4	4	4	4	2	2	2	2	
Switching frequency / max. output frequency	2 kHz	200								
	4 kHz	400								
	8 kHz	800								
Derating factor 2 to 4 kHz <sup>5)</sup>		-	-	-	-	0.89	0.81	0.77	0.77	
Derating factor 4 to 8 kHz <sup>5)</sup>		0.72	0.85	0.80	0.71	0.67	0.75	0.68	0.65	
<b>Other data</b>										
Can be connected in parallel up to 8 units <sup>4)</sup>		●	●	●	●	●	●	●	●	
Derating parallel operation		0.95	0.95	0.95	0.95	0.95	0.95	0.95	0.95	
DC bus capacity	[mF]	4.95	4.95	6.6	8.25	9.9	13.2	16.5	19.8	
Mains contactor		External								
Braking transistor/resistor		External								
<b>Control voltage data</b>										
Control voltage, external	[V]	DC 24 (±20 %)								
	[V]	DC 24 (±5 %) when supplying motor holding brake								
Power consumption (without control unit and motor brake)	[W]	41	48	53	46	48	55	58	65	
Continuous current (without control unit and motor brake)	[A]	1.7	2	2.2	1.9	2	2.3	2.4	2.7	

All data applies to nominal rating at 3 AC 400 V  
mains voltage and nominal switching frequency  
● Possible  
– Not possible

<sup>1)</sup> Base load for 9 min., 10 % overload for 1 min.

<sup>2)</sup> Base load for 9 min., 50 % overload for 1 min.

<sup>3)</sup> 4-pole asynchronous motor, 400 V, 50 Hz

<sup>4)</sup> up to 4 kHz, units of identical power

<sup>5)</sup> regarding to continuous current

<sup>6)</sup> balancing choke needed



► Performance

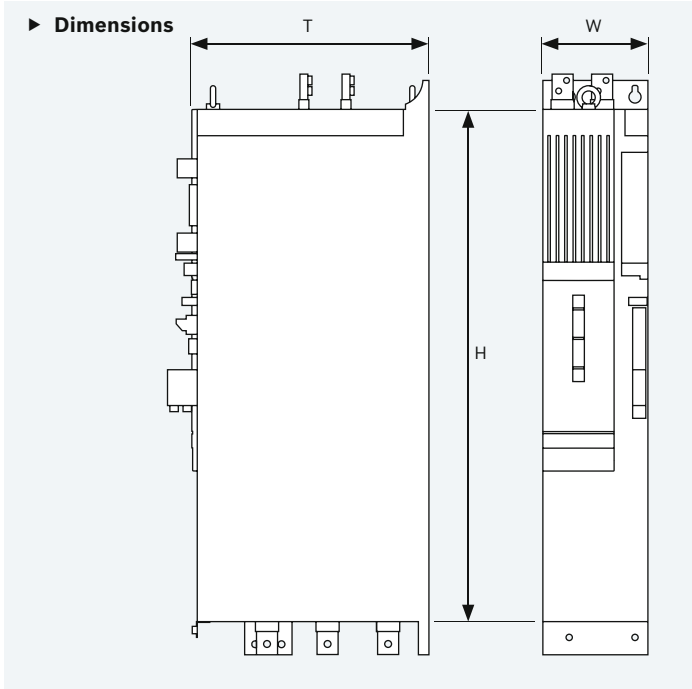
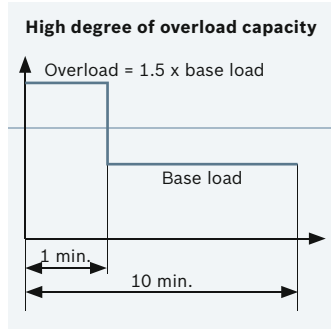
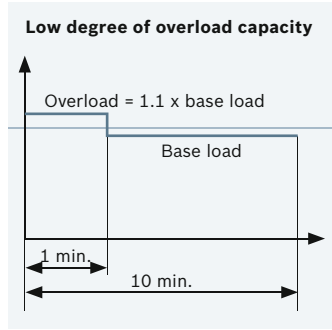
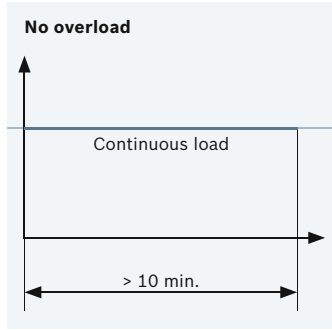

<b>Universal power inverter, liquid-cooled</b>	HMU05.1N-F0140-0350-N-A4-D7-_- _NNN	HMU05.1N-F0170-0430-N-A4-D7-_- _NNN	HMU05.1N-F0220-0510-N-A4-D7-_- _NNN	HMU05.1N-F0270-0660-N-A4-D7-_- _NNN	HMU05.1N-F0340-0820-N-A4-D7-P-_- _NNN	HMU05.1N-F0430-1040-N-A4-D7-P-_- _NNN	HMU05.1N-F0540-1300-N-A4-D7-P-_- _NNN	HMU05.1N-F0680-1690-N-A4-D7-P-_- _NNN
--	-------------------------------------	-------------------------------------	-------------------------------------	-------------------------------------	---------------------------------------	---------------------------------------	---------------------------------------	---------------------------------------

Mechanical data									
Height H	[mm]	687	687	791	895	973	1,181	1,389	1,389
Width W	[mm]	200	200	200	200	200	200	220	220
Depth T	[mm]	440	440	440	440	440	440	440	440
Mass	[kg]	51	51	58	65	70	83	103	i. p.
Protection type, device/connections					IP20 / IP00				

# Technical Data:

## HMU universal power inverter

### 525 - 690 V

<b>Universal power inverter, liquid-cooled</b>		HMU05.1N-F0140-0210-N-A5-11-___-MNNN	HMU05.1N-F0170-0250-N-A5-11-___-MNNN	HMU05.1N-F0220-0300-N-A5-11-___-MNNN	HMU05.1N-F0270-0370-N-A5-11-___-MNNN	HMU05.1N-F0400-0600-N-A5-11-___-MNNN	HMU05.1N-F0540-0750-N-A5-11-___-MNNN
<b>Power data as mains inverter</b>		Low degree of overload capacity <sup>1)</sup>   High degree of overload capacity <sup>2)</sup>					
DC bus baseline power	[kW]	144   120	173   144	216   173	270   216	400   315	535   430
DC bus overload power	[kW]	158   180	190   216	238   260	297   324	440   473	589   645
Line input current (baseline power)	[A]	125   105	151   125	188   151	235   188	349   274	466   375
DC bus continuous power	[kW]	144	173	216	270	400	535
Mains connection voltage	[V]	3 AC 525 to 690 (-15 % / +10 %)					
Supply frequency	[Hz]	50 / 60 (± 2Hz)					
DC bus voltage	[V]	Regulated, variable 1.56 x U <sub>supply</sub> or fix 1,100 V					
<b>Power data as motor inverter</b>		Low degree of overload capacity <sup>1)</sup>   High degree of overload capacity <sup>2)</sup>					
Typical motor rating <sup>3)</sup>	[kW]	132   110	160   132	200   160	250   200	355   315	500   400
Base-load current	[A]	146   122	175   146	216   175	281   216	365   353	575   442
Overload current	[A]	160   182	193   218	238   263	309   324	402   530	633   663
Continuous current	[A]	147	177	227	284	374	581
Maximum current	[A]	207	248	298	367	600	751
Nominal switching frequency	[kHz]	4	4	4	2	2	2
Switching frequency / max. output frequency	2 kHz	200					
	4 kHz	400					
	8 kHz	800					
Derating factor 2 to 4 kHz <sup>5)</sup>		–	–	–	i. p.	0.72	0.65
Derating factor 4 to 8 kHz <sup>5)</sup>		0.68	0.56	0.44	i. p.	0.52	0.33
<b>Other data</b>							
Can be connected in parallel up to 8 units <sup>4)</sup>		●	●	●	●	●	●
Derating parallel operation		0.95	0.95	0.95	0.95	0.95	0.95
DC bus capacity	[mF]	2.2	2.2	3.3	3.3	4.4	6.6
Mains contactor		External					
Braking transistor/resistor		External					
<b>Control voltage data</b>							
Control voltage, external	[V]	DC 24 (±20 %)					
	[V]	DC 24 (±5 %) when supplying motor holding brake					
Power consumption (without control unit and motor brake)	[W]	i. p.	i. p.	i. p.	i. p.	i. p.	i. p.
Continuous current (without control unit and motor brake)	[A]	i. p.	i. p.	i. p.	i. p.	i. p.	i. p.

All data applies to nominal rating at 3 AC 690 V mains voltage and nominal switching frequency

● Possible  
– Not possible

<sup>1)</sup> Base load for 9 min., 10 % overload for 1 min.

<sup>2)</sup> Base load for 9 min., 50 % overload for 1 min.

<sup>3)</sup> 4-pole asynchronous motor, 690 V, 50 Hz

<sup>4)</sup> up to 4 kHz, units of identical power

<sup>5)</sup> regarding to continuous current

<sup>6)</sup> balancing choke needed

► Performance

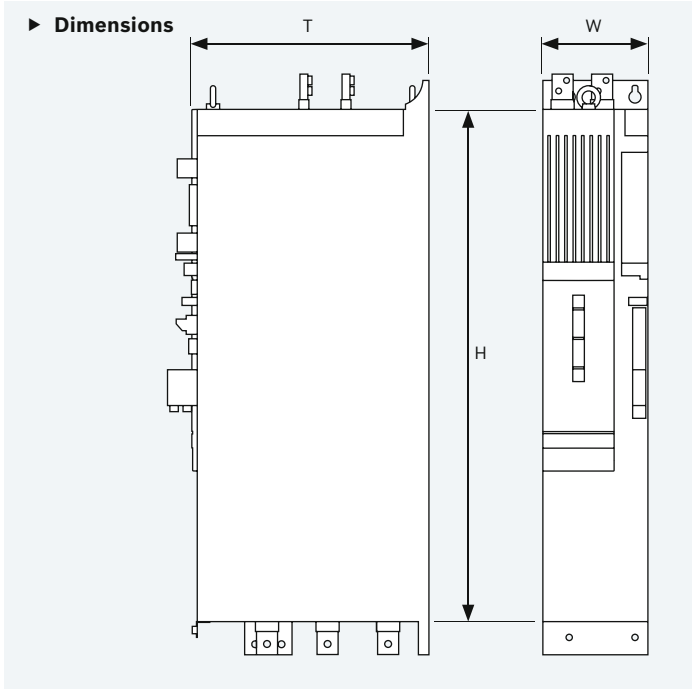
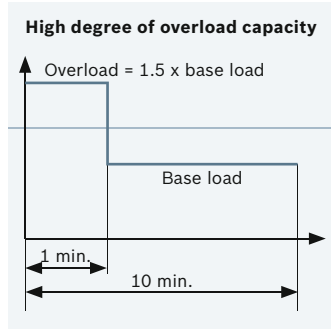
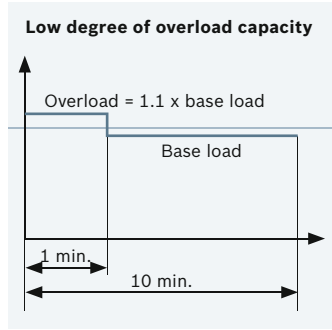
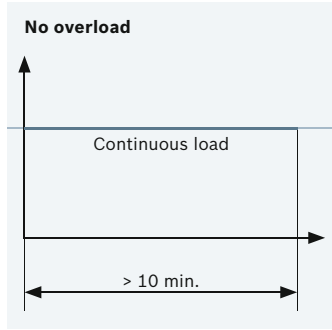

Universal power inverter, liquid-cooled		HMU05.1N-F0140-0210-N-A5-11-_-MNNN	HMU05.1N-F0170-0250-N-A5-11-_-MNNN	HMU05.1N-F0220-0300-N-A5-11-_-MNNN	HMU05.1N-F0270-0370-N-A5-11-_-MNNN	HMU05.1N-F0400-0600-N-A5-11-_-MNNN	HMU05.1N-F0540-0750-N-A5-11-_-MNNN
<b>Mechanical data</b>							
Height H	[mm]	687	687	791	791	895	1.181
Width B	[mm]	200	200	200	200	200	220
Depth T	[mm]	440	440	440	440	440	440
Mass	[kg]	i. p.	i. p.	i. p.	i. p.	i. p.	i. p.
Protection type, device / connections				IP20 / IP00			

# Technical Data: CSB and CSH control units



Onboard interfaces	BASIC CSB02.5B	ADVANCED CSH02.5B-ET	ADVANCED CSH02.5B-CC
Multi Ethernet	●	●	-
Sercos master	-	-	●
Multi-encoder	●	●	●
Engineering port	-	-	●
Operating panel	Standard	Advanced	Advanced
Digital inputs	●	●	●
Probe inputs	●	●	●
Digital I/Os (configurable)	●	●	●
Analog input, ±10 V	●	●	●
Analog input, 0 - 20 mA	●	●	●
Analog output, ±10 V	●	●	●
Optional interfaces			
CANopen	●	-	●
PROFIBUS DP	●	-	●
Multi Ethernet	-	-	●
Multi-encoder	●	●	●
Encoder emulation	●	●	●
I/O extension, digital/analog	●	●	●
Safe Torque Off	●	●	●
Safe Motion	●	●	●

● Possible - Not possible

**BASIC control unit**  
Performance hardware for basic applications and standard servo applications

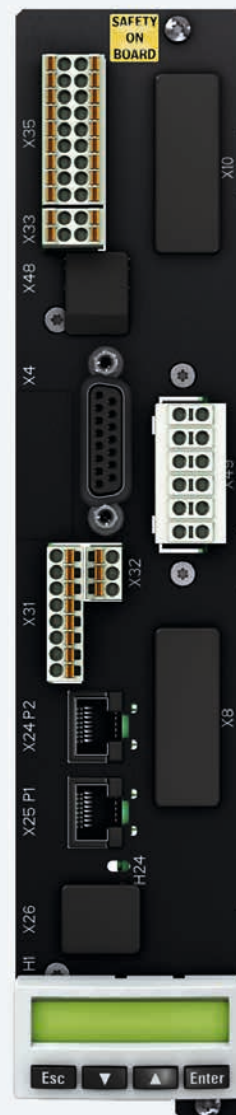

**ADVANCED control unit**  
Hardware with ultra-high performance for high-end servo applications and master for multi-axis motion logic



# Accessories

## Power line connection module

Required to operate the universal power inverter as a mains inverter with the following functions:

- ▶ Precharge DC bus capacitors
- ▶ Measure supply voltage
- ▶ Actuate line contactor
- ▶ Exchange messages with the entire drive system



## Line choke and line filter

Coordinated unit comprising a commutating reactor and filter for high noise immunity and low emissions.

## DC bus choke

Allows the number of axes to be increased with high leakage capacitance for motors and cables.

## Braking transistor unit and braking resistor

For converting braking energy if energy cannot be channeled back to the power supply network.

## Control voltage power supply unit

Generates the 24 V control voltage from the power supply and DC bus. Ensures continued operation of all devices and units connected, including after a power failure.

## Motor chokes

For reducing the rate of voltage rise (dv/dt). Allows motors to be operated with limited dielectric strength.

## Motor filter

Smooths the output voltage to an almost sinusoidal waveform. This reduces the discharge currents of shielded cables while keeping the interference emissions of unshielded cables to a minimum.

## Balancing chokes

Ensure optimal use of motor inverters connected in parallel for achieving high outputs of up to 4 MW.

## Assembly aid

The assembly and disassembly aid alleviates handling when installing the universal inverter in the control cabinet.

## Heat exchanger

For cooling liquid-cooled devices

- ▶ Water-water heat exchangers for dissipating heat loss in process water or for use in heat recovery systems
- ▶ Water-air heat exchangers for simple dissipation of lost heat into the air

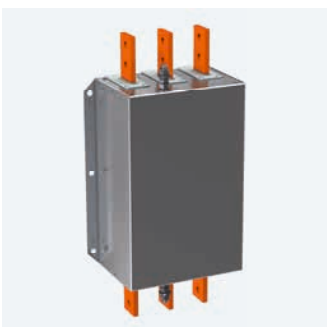
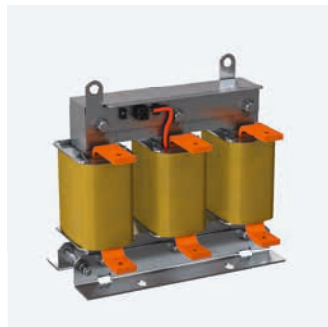

# Control cabinets: Overall package for optimal solutions



## Complete control cabinet solutions

Upon request, we also supply the IndraDrive ML drive systems up to the Megawatt range fully installed and wired. Complete control cabinet solutions are produced based on customer- and application-specific requirements – for powers of up to 4 MW and in the voltage range of 380 - 690 V. Depending on the desired cooling type and protection class of the control cabinet, various designs are feasible for cooling any energy loss arising depending on the situation.

For the drive components:

- ▶ Water-water heat exchanger
- ▶ Water-air heat exchanger

For additional air-cooled components in the cabinet:

- ▶ Air-water heat exchanger
- ▶ Air conditioners
- ▶ Open-circuit ventilation

In accordance with the regional requirements, the control cabinet receives a CE declaration of conformity or for instance a UL certification for the North American market. Of course with additional documentation such as circuit diagram in EPLAN, components parts list etc. Additional options or alternative designs may be supplied in accordance with customer requirements, for example:

- ▶ DC-outgoing feeders for connecting smaller drives
- ▶ Panels for control technology of additional components
- ▶ Individual wire designation
- ▶ Various mechanical cabinet designs
- ▶ Network contactor or other controllable main switches

## Benefits of packages

- ▶ Coverage of the entire process from a single source – from planning, development and design, through preliminary acceptance of switch cabinet construction right up to commissioning on the customer's premises
- ▶ Comprehensive package tailored to the application guarantees optimal solution
- ▶ Coverage of a wide surrounding area – from installation in spaces for electrical operating material right up to deployment in the machine environment



# Motors: As diverse as the applications



## Motors for the entire power and requirements range

The requirements on the motor's torque-speed characteristics are highly diverse due to the wide operating range in various applications. They inevitably result in characteristics which are optimized in terms of:

- ▶ High torques at low speeds
- ▶ High powers in a broad speed range
- ▶ High dynamics with small moments of inertia

We cover the entire power and requirements range with solutions from a single source, both for motors from our own IndraDyn production range as well as motors from collaborations with other manufacturers. From design right up to commissioning.



Optimized operation is achieved depending on motor design, both synchronous and asynchronous, by means of a high level of control dynamics and PWM frequency in various control types:

- ▶ Voltage-frequency-control, without encoder (U/f)
- ▶ Flux-controlled operation, without encoder (FXC)
- ▶ Field-oriented current control, without encoder (FOCs1)
- ▶ Field-oriented current control, with encoder (FOC)



Depending on the ambient conditions, various designs are possible with respect to protection class and type of cooling as well as mechanical design with respect to casing, bearing etc.

Upon request, existing motors can also be run using output chokes or filters.



## Benefits

- ▶ Coordinated motor-inverter combination from a single source
- ▶ Efficient operation by means of high PWM frequency and intelligent drive functions
- ▶ Broad spectrum of motor designs and options

R999000340 (2016-11)  
© Bosch Rexroth AG 2016  
Subject to revisions!

The data specified above only serve to describe the product. No statements concerning a certain condition or suitability for a certain application can be derived from our information. The information given does not release the user from the obligation of own judgment and verification. It must be remembered that our products are subject to a natural process of wear and aging.