

# Greaves

## Double Reduction Speed Reducers

Greaves Double Reduction Speed Reducers are two stage worm reduction units. A specially designed primary worm reduction unit is integrally mounted on a standard single reduction Greaves worm reducer which forms the second stage. The composite units provide the most compact and rigid arrangement for large reduction of speed necessary for slow moving machinery. A wide range of ratios upto 4900:1 is available.

The wormshafts are made of high quality case hardening steel, accurately generated, ground and superfinished. The wormwheels comprise of phosphor bronze centrifugally cast rims of substantial sections welded to rigid centres. Considerable flexibility of shaft layout is permissible with all types of Double Reduction units. The dimension drawing for each series shows the different shaft handing arrangements and the appropriate reference should always be quoted when ordering.

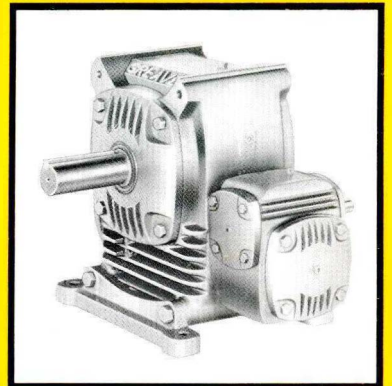
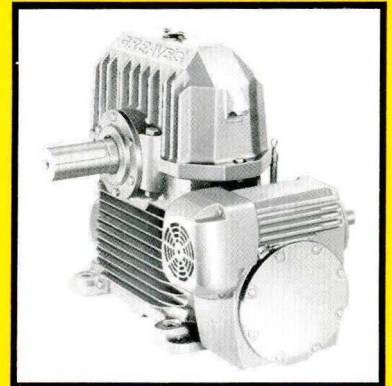

# GREAVES Double Reduction Adaptable Speed Reducers

## TYPE AUD

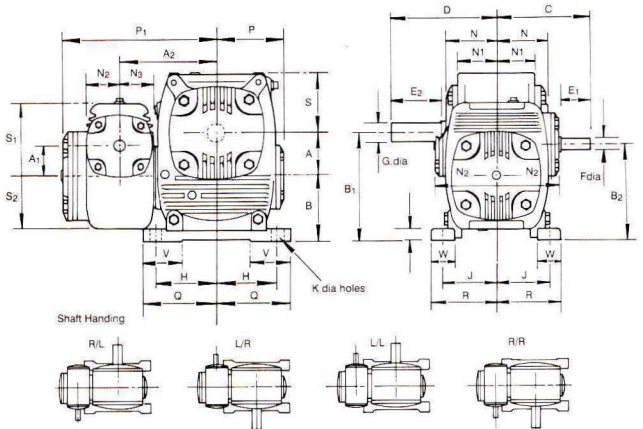

Care should be taken when using "L/L" or "R/R" to ensure that the motor, where direct coupled, will clear the slow-speed shaft.

## TYPE AOD

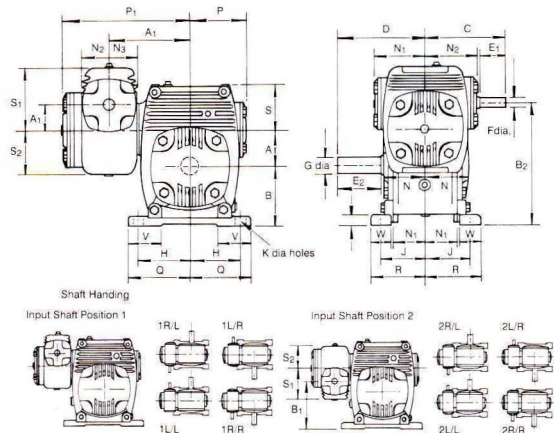

Care should be taken when using "1L/L", "1R/R", "2L/L" or "2R/R" to ensure that the motor, where direct coupled, will clear the slow-speed shaft.

## TYPE AVD

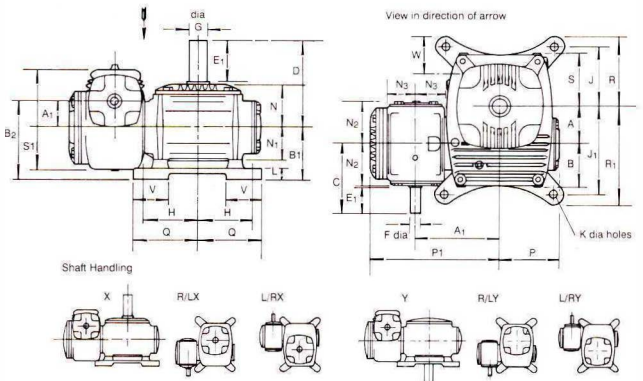

Designations with suffix "X" e.g. "R/LX", denote units with slow-speed shafts extended vertically upward. Suffix "Y", e.g. "R/LY" refers to units with slow-speed extended vertically downward.  
 Note: The slow speed shaft extension, when downward, is the same dimensionally as the upward projection from the high-speed shaft centre-line. Dimensions D, E2 and N apply to both arrangements.

# Principal Dimensions (mm)

## AUD

Size	A	A <sub>1</sub>	A <sub>2</sub>	B	B <sub>1</sub>	B <sub>2</sub>	C	D	E <sub>1</sub>	E <sub>2</sub>	F	G	H	J	K	L	N	N <sub>1</sub>	N <sub>2</sub>	N <sub>3</sub>	P	P <sub>1</sub>	Q	R	S	S <sub>1</sub>	S <sub>2</sub>	V	W
162	41.3	28.6	92.1	60.3	101.6	88.9	90	98	29	48	11.113 11.102	19.050 19.037	58.7	49.2	10.3	11	49	37	59	32	68	148	70	60	60	70	51	38	22
200	50.8	28.6	106.4	69.9	120.7	98.4	90	117	29	57	11.113 11.102	25.400 25.387	76.2	57.2	10.3	14	59	43	59	32	84	162	91	73	74	70	51	49	29
237	60.3	41.3	133.4	84.1	144.5	125.4	110	140	41	70	15.875 15.865	28.575 28.562	87.3	68.3	11.9	17	68	51	68	46	98	208	103	84	87	92	67	54	32
287	73.0	41.3	152.4	95.3	168.3	136.5	110	168	41	83	15.875 15.865	31.750 31.735	106.4	82.6	13.5	19	81	64	68	46	119	227	124	100	106	92	67	60	35
337	85.7	41.3	168.3	109.5	195.3	150.8	110	200	41	98	15.875 15.865	38.100 38.085	119.1	96.8	15.1	21	98	76	68	46	133	243	138	116	119	92	67	67	38

## AOD

Size	A	A <sub>1</sub>	A <sub>2</sub>	B	B <sub>1</sub>	B <sub>2</sub>	C	D	E <sub>1</sub>	E <sub>2</sub>	F	G	H	J	K	L	N	N <sub>1</sub>	N <sub>2</sub>	N <sub>3</sub>	P	P <sub>1</sub>	Q	R	S	S <sub>1</sub>	S <sub>2</sub>	V	W
162	41.3	28.6	92.1	66.7	79.4	136.5	90	98	29	48	11.113 11.102	19.050 19.037	58.7	49.2	10.3	11.1	49	37	59	32	68	148	70	60	54	70	51	38	22
200	50.8	28.6	106.4	82.6	104.8	161.9	90	117	29	57	11.113 11.102	25.400 25.387	76.2	57.2	10.3	14.3	59	43	59	32	84	162	91	73	62	70	51	49	29
237	60.3	41.3	133.4	100.00	119.1	201.6	110	140	41	70	15.875 15.865	28.575 28.562	87.3	68.3	11.9	17.5	68	51	68	46	98	208	103	84	71	92	67	54	32
287	73.0	41.3	152.4	120.7	152.4	235.0	110	168	41	83	15.875 15.865	31.750 31.735	106.4	82.6	13.5	19.1	81	64	68	46	119	227	124	100	81	92	67	60	35
337	85.7	41.3	168.3	134.9	179.4	261.9	110	200	41	98	15.875 15.865	38.100 38.085	119.1	96.8	15.1	20.6	98	76	68	46	133	243	138	116	94	92	67	67	38

## AVD

Size	A	A <sub>1</sub>	A <sub>2</sub>	B	B <sub>1</sub>	B <sub>2</sub>	C	D	E <sub>1</sub>	E <sub>2</sub>	F	G	H	J	J <sub>1</sub>	K	L	N	N <sub>1</sub>	N <sub>2</sub>	N <sub>3</sub>	P	P <sub>1</sub>	Q	R	R <sub>1</sub>	S	S <sub>1</sub>	S <sub>2</sub>	V	W
162	41.3	28.6	92.1	54.0	63.5	92.1	90	98	29	48	11.113 11.102	19.050 19.037	58.7	65.1	100.0	10.3	14	49	37	59	32	68	148	71	78	113	60	70	51	40	46
200	50.8	28.6	106.4	61.9	69.9	98.4	90	117	29	57	11.113 11.102	25.400 25.387	76.2	82.6	120.7	10.3	14	59	43	59	32	84	162	89	95	133	75	70	51	51	52
237	60.3	41.3	133.4	71.4	82.6	123.8	110	140	41	70	15.875 15.865	28.575 28.562	87.3	95.3	139.7	11.9	17	68	51	68	46	98	208	103	111	156	87	92	67	57	59
287	73.0	41.3	152.4	81.0	98.4	139.7	110	168	41	83	15.875 15.865	31.750 31.735	106.4	114.3	161.9	13.5	21	81	64	68	46	119	227	124	132	179	106	92	67	65	65
337	85.7	41.3	168.3	93.7	114.3	155.6	110	200	41	98	15.875 15.865	38.100 38.085	119.1	128.6	188.9	15.1	22	98	76	68	46	133	243	138	148	208	119	92	67	73	73



# GREAVES Double Reduction solid foot Speed Reducers

## UD

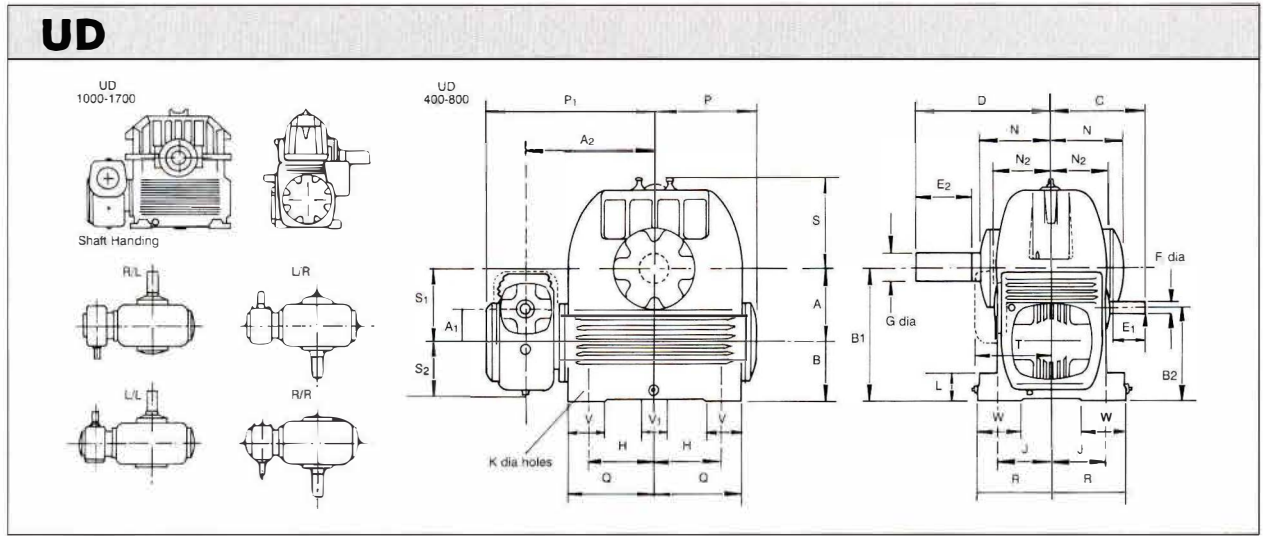

## OD

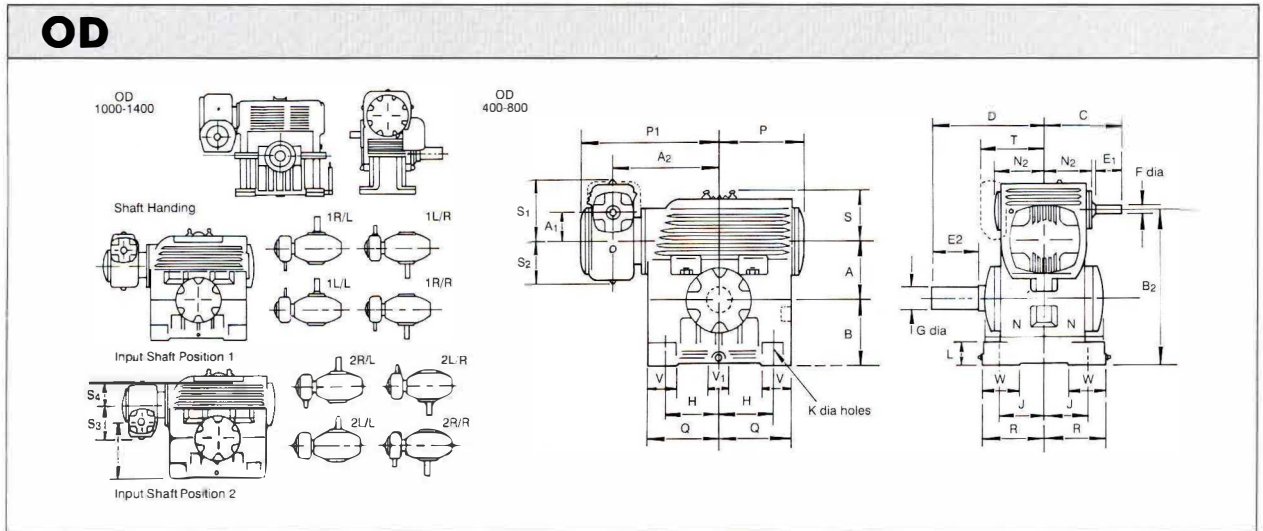

## VD

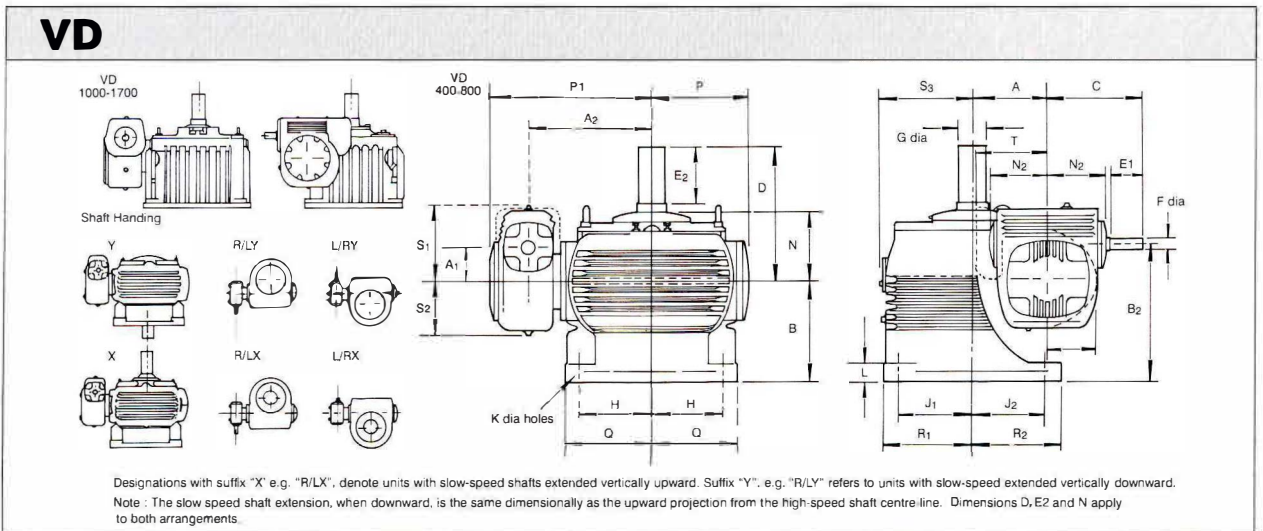

Designations with suffix "X" e.g. "R/LX" denote units with slow-speed shafts extended vertically upward. Suffix "Y", e.g. "R/LY" refers to units with slow-speed extended vertically downward. Note: The slow speed shaft extension, when downward, is the same dimensionally as the upward projection from the high-speed shaft centre line. Dimensions D, E2 and N apply to both arrangements.

# Principal Dimensions (mm)

UD																													
Size	A	A1	A2	B	B1	B2	C	D	E1	E2	F	G	H	J	K	L	N	N2	P	P1	Q	R	S	S1	S2	T	V	V1	W
400	101.6	50.8	214.3	108.0	209.6	158.8	133	216	48	89	15.87	44.45	108.0	101.6	20.6	44	121	84	159	276	140	127	137	116	78	-	64	-	76
500	127.0	60.3	247.7	114.3	214.3	174.6	159	248	57	102	19.05	50.80	123.8	111.1	20.6	54	133	100	184	319	164	137	159	132	90	-	70	-	83
600	152.4	73.0	265.1	127.0	279.4	200.0	191	273	70	114	22.2	57.15	133.4	120.7	23.8	64	140	119	200	346	179	149	184	156	110	-	76	-	89
700	177.8	85.7	304.8	146.1	323.9	231.8	219	298	83	127	25.4	63.50	152.4	133.4	23.8	70	151	135	229	400	208	162	210	184	124	-	89	-	98
800	203.2	101.6	336.6	146.1	349.3	247.7	229	311	67	140	31.75	69.85	171.5	133.4	27.0	76	159	162	251	441	230	171	235	203	137	222	102	-	102
1000	254.0	127.0	419.1	171.5	425.5	298.5	260	375	73	152	38.1	82.55	215.9	165.1	31.8	51	194	178	311	549	298	200	292	241	165	254	127	64	200
1200	304.8	152.4	479.4	190.5	495.3	342.9	279	413	76	171	38.1	95.25	260.4	184.2	34.9	57	216	191	368	625	356	222	343	284	186	270	152	76	222
1400	355.6	177.8	552.5	215.9	571.5	393.7	318	483	86	191	44.4	114.30	298.5	215.9	41.3	64	254	222	425	702	413	260	394	314	232	305	178	89	260
1700	431.8	203.2	660.4	254.0	685.8	457.2	343	546	89	203	44.4	139.70	381.0	254.0	41.3	76	305	250	514	822	502	298	489	349	254	327	191	127	298

OD																															
Size	A	A1	A2	B	B1	B2	C	D	E1	E2	F	G	H	J	K	L	N	N2	P	P1	Q	R	S	S1	S2	S3	S4	T	V	V1	W
400	101.6	50.8	214.3	120.7	171.5	273.1	133	216	48	89	15.87	44.45	108.0	101.6	20.6	44	121	84	159	276	140	127	108	116	78	116	78	-	64	-	76
500	127.0	60.3	247.7	146.1	212.7	333.4	139	248	57	102	19.05	50.80	123.8	111.1	20.6	54	133	100	184	319	164	137	117	132	90	132	90	-	70	-	83
600	152.4	73.0	265.1	171.5	250.8	396.9	191	273	70	114	22.2	57.15	133.4	120.7	23.8	64	140	119	200	346	179	149	124	156	110	156	110	-	76	-	89
700	177.8	85.7	304.8	196.9	288.9	460.4	219	296	83	127	25.4	63.50	152.4	133.4	23.8	70	151	135	229	400	208	162	165	184	124	184	124	-	89	-	98
800	203.2	101.6	336.6	222.3	223.8	527.1	229	311	67	140	31.75	69.85	171.5	133.4	27.0	76	159	162	251	441	230	171	165	203	137	203	137	222	102	-	102
1000	254.0	127.0	419.1	273.1	400.1	654.1	260	375	73	152	38.1	82.55	215.9	165.1	31.8	51	194	178	311	549	298	200	191	241	165	241	171	254	127	64	200
1200	304.8	152.4	479.4	330.2	482.6	787.4	279	413	76	171	38.1	95.25	260.4	184.2	34.9	57	216	191	368	625	356	222	203	284	186	284	186	270	152	76	222
1400	355.6	177.8	552.5	381.0	558.8	914.4	343	483	86	191	44.4	114.30	298.5	215.9	41.3	64	254	222	425	702	413	260	229	314	232	314	232	305	178	89	260

VD																												
Size	A	A1	A2	B	B2	C	D	E1	E2	F	G	H	J1	J2	K	L	N	N2	P	P1	Q	R1	R2	S	S1	S2	S3	T
400	101.6	50.8	214.3	171.5	222.3	133	216	48	89	15.87	44.45	114.3	114.3	114.3	20.6	32	121	84	159	276	140	140	140	98.4	116	78	152	-
500	127.0	60.3	247.7	190.5	250.8	159	248	57	102	19.05	50.8	139.7	139.7	139.7	20.6	32	133	100	184	319	165	165	165	111	132	90	178	-
600	152.4	73.0	265.1	209.6	282.6	191	273	70	114	22.2	57.15	152.4	152.4	152.4	23.8	38	140	119	200	346	184	184	184	120	155.8	110	197	-
700	177.8	85.7	304.8	228.6	314.3	219	298	83	127	25.4	63.50	177.8	177.8	177.8	23.8	38	151	135	229	400	210	210	210	130	184	124	222	-
800	203.2	101.6	336.6	241.3	342.9	229	311	67	140	31.75	69.85	203.2	203.2	203.2	27.0	44	159	162	251	449	238	238	238	136.5	203	137	254	222
1000	254.0	127.0	419.1	279.4	406.4	260	375	73	152	38.1	82.55	260.4	260.4	235.0	31.8	51	194	178	311	549	311	299	273	173	241	165	298	254
1200	304.8	152.4	479.4	304.8	457.2	279	413	76	171	38.1	95.25	317.5	317.5	266.7	34.9	57	216	191	368	625	368	356	305	150.5	284	186	356	270
1400	355.6	177.8	552.5	330.2	508.0	318	483	86	191	44.4	114.30	355.6	355.6	304.8	41.3	64	254	222	425	702	425	413	362	216	314	232	413	305
1700	431.8	203.2	660.4	406.4	609.6	343	546	89	203	44.4	139.70	431.8	431.8	431.8	41.3	76	305	250	514	822	502	502	502	254	349	254	502	327

# GREAVES Double Reduction Adaptable Speed Reducers

## LUBRICATION

The primary and secondary units of double reduction Greaves ADAPTABLE units must be filled separately, with recommended oil. Plugs have been provided on all sides of the unit. The plugs at extreme top serve as oil filler and breather, the bottom plugs are for drain and the plug in between is to be used for oil level checking. Over-filling should be avoided; this might result in oil leakage and over-heating.

### RECOMMENDED LUBRICANT

#### ISO VG320

Brand	Grade
Bharat Petroleum	Cabol 320 or Amocam 320
Castrol	Alpha ZN 320
Gulf	Harmony 320
Hindustan Petroleum	Enklo 320
Indian Oil	Servomesh SP320 or Servosystem 320
Veedol	Aavalon 320

### Approximate Shipping Specification and Oil Capacities

Size	162	200	237	287	337
Net Weight (kg)	10	14.5	24.5	37	51
Gross Weight (kg)	15	20	32	48	66
Volume packed (Cu.m.)	0.034	0.040	0.057	0.079	.125
Oil required Primary Unit at 1 <sup>st</sup> filling (litres)	0.14	0.14	0.28	0.28	0.28
Final Unit	0.28	0.28	0.57	0.85	1.42

A supply of oil is not included in any unit

As improvements in design are continually being made, this specification is not to be regarded as binding in detail and dimensions are subject to alteration without notice.

# Standard Shaft Dimensions (mm)

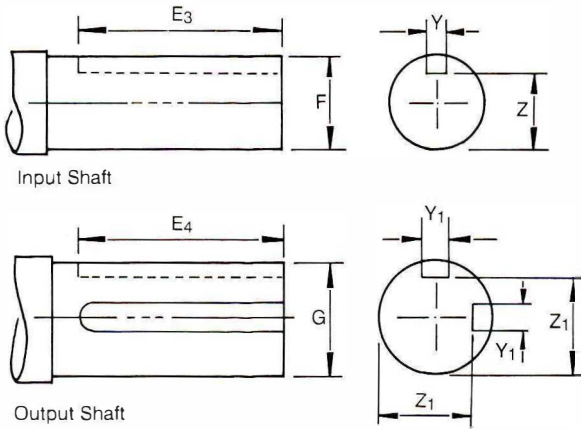

Size	Input Shaft				Output Shaft			
	F	E2	Y	Z	G	E4	Y1	Z1
400	15.875	44	4.78	13.16	44.450	83	11.13	39.73
	15.865		4.75	13.00	44.435		11.10	39.57
500	19.050	54	4.78	16.33	50.800	95	12.70	45.97
	19.037		4.75	16.18	50.782		12.67	45.82
600	22.225	67	6.35	18.62	57.150	114	15.88	50.55
	22.212		6.32	18.47	57.135		15.85	50.39
700	25.400	79	6.35	21.79	63.500	114	15.88	56.90
	25.387		6.32	21.64	63.482		15.85	56.74
800	31.750	54	7.95	28.04	69.850	127	19.05	62.26
	31.735		7.92	27.89	69.832		19.02	62.10
1000	38.100	73	9.53	34.29	82.550	143	22.23	73.15
	38.085		9.50	34.14	82.527		22.20	73.00
1200	38.100	73	9.53	34.29	95.250	162	25.40	84.05
	38.085		9.50	34.14	95.227		25.37	83.90
1400	44.450	83	11.13	39.73	114.300	210	31.75	101.14
	44.435		11.10	39.57	114.277		31.70	100.99
1700	44.450	83	11.13	39.73	139.700	222	38.10	124.49
	44.435		11.10	39.57	139.675		38.05	124.33

## Direction of Rotation

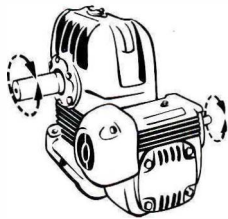

UD - shaft handing "R/L"

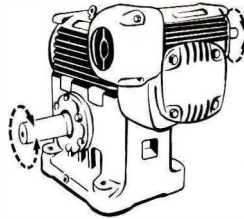

OD - shaft handing "1R/L"

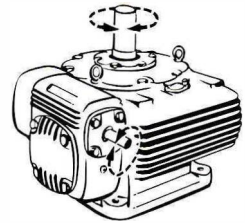

VD - shaft handing "R/LX"

## Shipping Specifications and Oil Capacity (approx.)

SIZE OF UNIT	NET WEIGHT (KG.)			GROSS WEIGHT (KG.)			VOLUME PACKED (CU.M)			PRIMARY UNIT	OIL CAPACITY (LITRE)		
	UD	OD	VD	UD	OD	VD	UD	OD	VD		SECONDARY UNIT		
											UD	OD	VD
400	73	87	76	88	108	95	.14	.14	.17	0.6	2.8	2.3	4.0
500	116	122	129	145	151	162	.20	.20	.24	0.6	4.0	2.8	5.7
600	166	155	177	204	193	222	.30	.28	.32	1.1	5.7	4.0	6.3
700	218	228	253	273	285	319	.38	.43	.49	1.7	9.1	5.7	10.2
800	268	280	305	324	336	382	.45	.48	.54	2.8	11.4	9.1	12.5
1000	419	450	540	550	591	690	.74	.79	.88	4.0	17.5	6.8	22.7
1200	634	682	790	775	864	982	1.02	1.16	1.13	5.7	23.0	7.9	37.4
1400	945	1046	1096	1172	1318	1415	1.47	1.59	1.67	9.1	37.0	18.2	68.5
1700	1650	-	1800	1875	-	2100	2.35	-	2.60	11.5	55.0	-	90.0



# Type BS double reduction

BSU  
10-14

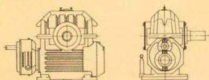

BSU  
400-800

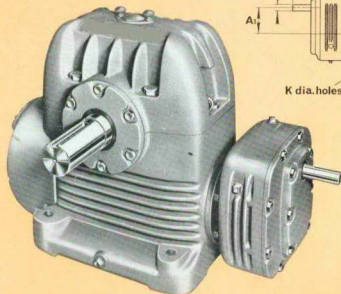
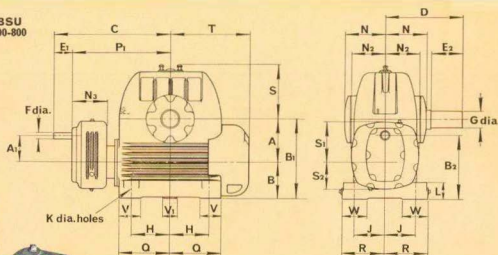

## Shaft Handling

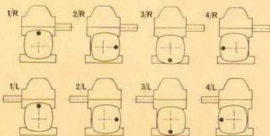

# BSU

Size	A	A <sub>1</sub>	B	B <sub>1</sub>	B <sub>2</sub>	C	D	E <sub>1</sub>	E <sub>2</sub>	F	G	H	J	K	L	N	N <sub>2</sub>	N <sub>2</sub>	P <sub>1</sub>	Q	R	S	S <sub>1</sub>	S <sub>2</sub>	T	V	V <sub>1</sub>	W	
400	4	3	4½	8½	7½	13½	8½	2½	3½	2	1½	4½	4	1½	1½	4½	4½	4½	11½	5½	5	5½	5	3½	8½	2½	—	3	
500	5	3	4½	9½	7½	14½	9½	2½	4	2	2	4½	4½	1½	2½	5½	4½	4½	12½	6½	5½	6½	5	3½	10	2½	—	3½	
600	6	3½	5	11	8½	16	10½	2½	4½	2½	2½	5½	4½	1½	2½	5½	4½	4½	13½	7½	5½	7½	5½	3½	10½	3	—	3½	
700	7	4½	5½	12½	10½	18	11½	2½	5	1½	2½	6	5½	1½	2½	5½	5½	5½	15½	8½	6½	8½	7½	4½	12	3½	—	3½	
800	8	4½	5½	13½	10½	19	12½	2½	5½	1½	2½	6½	5½	1½	3	6½	5½	5½	16½	9½	6½	9½	7½	4½	12½	4	—	4	
10	10	5	6½	16½	11½	23	14½	3½	6	1½	3½	8½	6½	1½	2	7½	6½	6½	19½	11½	11½	7½	11½	8½	5½	14½	5	2½	7½
12	12	6	7½	19½	13½	26	16½	4	6½	1½	3½	10½	7½	1½	2½	8½	7½	7½	22	14	8½	13½	9½	6	17½	6	3	8½	
14	14	7	8½	22½	15½	30	19	4½	7½	1½	4½	11½	8½	1½	2½	10	9	8½	25½	16½	10½	15½	11½	6½	20½	7	3½	10½	

Shaft tolerances conform to B.S.1916:1953, h6. Keyways are to B.S.46:1958. Refer to page 18 for Standard Shaft Tolerances and Keyway Details. The facing V<sub>1</sub> is provided on Sizes 10, 12 and 14 only.



# Principal dimensions (inches)



BSO  
10-14



BSO  
400-800

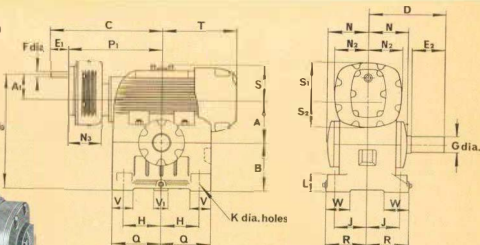
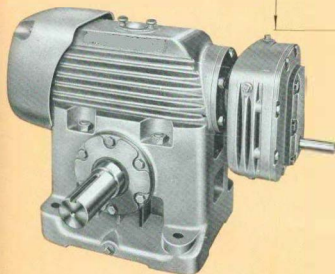

### Shaft Handling

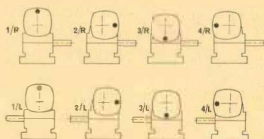

# BSO

Size	A	A <sub>1</sub>	B	B <sub>1</sub>	C	D	E <sub>1</sub>	E <sub>2</sub>	F	G	H	J	K	L	N	N <sub>1</sub>	N <sub>2</sub>	P <sub>1</sub>	Q	R	S	S <sub>1</sub>	S <sub>2</sub>	T	V	V <sub>1</sub>	W
400	4	3	4 1/2	11 1/2	13 1/2	8 1/2	2 1/2	3 1/2	1 1/2	4 1/2	4	1 1/2	1 1/2	4 1/2	4 1/2	4 1/2	11 1/2	5 1/2	5	4 1/2	5	3 1/2	8 1/2	2 1/2	—	—	3
500	5	3	5 1/2	13 1/2	14 1/2	9 1/2	2 1/2	4	2	4 1/2	4 1/2	1 1/2	2 1/2	5 1/2	4 1/2	4 1/2	12 1/2	6 1/2	5 1/2	4 1/2	5	3 1/2	10	2 1/2	—	—	3 1/2
600	6	3 1/2	6 1/2	16 1/2	16	10 1/2	2 1/2	4 1/2	2 1/2	5 1/2	4 1/2	1 1/2	2 1/2	5 1/2	4 1/2	4 1/2	13 1/2	7 1/2	5 1/2	4 1/2	5 1/2	3 1/2	10 1/2	3	—	—	3 1/2
700	7	4 1/2	7 1/2	19 1/2	18	11 1/2	2 1/2	5	1 1/2	2 1/2	6	5 1/2	1 1/2	2 1/2	5 1/2	5 1/2	15 1/2	8 1/2	6 1/2	6 1/2	7 1/2	4 1/2	12	3 1/2	—	—	3 1/2
800	8	4 1/2	8 1/2	21 1/2	19	12 1/2	2 1/2	5 1/2	1 1/2	2 1/2	6 1/2	5 1/2	1 1/2	3	6 1/2	5 1/2	16 1/2	9 1/2	6 1/2	6 1/2	7 1/2	4 1/2	12 1/2	4	—	—	4
10	10	5	10 1/2	25 1/2	23	14 1/2	3 1/2	6	1 1/2	3 1/2	8 1/2	6 1/2	1 1/2	2	7 1/2	6 1/2	19 1/2	11 1/2	7 1/2	7 1/2	8 1/2	5 1/2	14 1/2	5	2 1/2	—	7 1/2
12	12	6	13	31	26	16 1/2	4	6 1/2	1 1/2	3 1/2	10 1/2	7 1/2	1 1/2	2 1/2	8 1/2	7 1/2	22	14	8 1/2	8 1/2	9 1/2	6	17 1/2	6	3	—	8 1/2
14	14	7	15	36	30	19	4 1/2	7 1/2	1 1/2	4 1/2	11 1/2	8 1/2	1 1/2	2 1/2	10	9	8 1/2	25 1/2	16 1/2	10 1/2	9 1/2	11 1/2	6 1/2	20 1/2	7	3 1/2	10 1/2

Shaft tolerances conform to B.S.1916:1953, h6. Keyways are to B.S.46:1958. Refer to page 18 for Standard Shaft Tolerances and Keyway Details. The facing V<sub>1</sub> is provided on Sizes 10, 12 and 14 only.

# Type BS double reduction

## Principal dimensions (inches)

BSV  
10-14

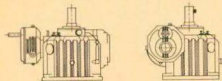

BSV  
400-800

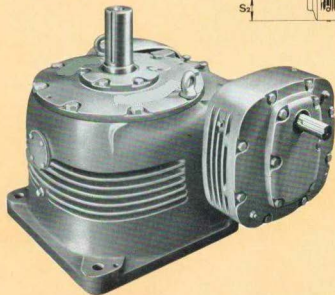
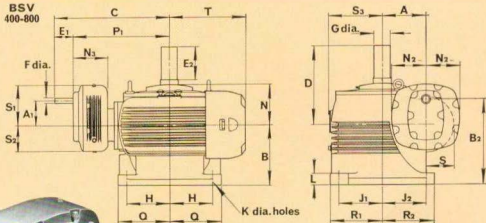

### Shaft Handing

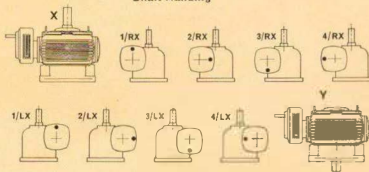

# BSV

Designations with suffix "X", e.g. "1/RX", denote units with slow-speed shafts extended vertically upward. Suffix "Y", e.g. "1/RX/Y", refers to units with slow-speed shafts extended vertically downward. Note: The slow speed shaft extension, when downward, is the same dimensionally as the upward projection from the high speed shaft centre-line. Dimensions D, E, and N apply to both arrangements

Size	A	A <sub>1</sub>	B	B <sub>2</sub>	C	D	E <sub>1</sub>	E <sub>2</sub>	F	G	H	J <sub>1</sub>	J <sub>2</sub>	K	L	N	N <sub>2</sub>	N <sub>3</sub>	P <sub>1</sub>	Q	R <sub>1</sub>	R <sub>2</sub>	S	S <sub>1</sub>	S <sub>2</sub>	T	
400	4	3	6½	9½	13½	8½	2½	3½	½	1½	4½	4½	4½	1½	4½	4½	4½	4½	11½	5½	5½	5½	4½	5	3½	6	8½
500	5	3	7½	10½	14½	9½	2½	4	¾	2	5½	5½	5½	1½	5½	4½	4½	12½	6½	6½	6½	4½	5	3½	7	10	
600	6	3½	8½	11½	16	10½	2½	4½	¾	2½	6	6	6	1½	1½	5½	4½	4½	13½	7½	7½	7½	5½	5½	3½	7½	10½
700	7	4½	9	13½	18	11½	2½	5	1½	2½	7	7	7	1½	1½	5½	5½	5½	15½	8½	8½	8½	5½	7½	4½	8½	12
800	8	4½	9½	14	19	12½	2½	5½	1½	2½	8	8	8	1½	1½	6½	5½	5½	16½	9½	9½	9½	5½	7½	4½	10	12½
10	10	5	11	16	23	14½	3½	6	1½	3½	10½	10½	9½	1½	2	7½	6½	6½	19½	12½	11½	10½	6½	8½	5½	11½	14½
12	12	6	12	18	26	16½	4	6½	1½	3½	12½	12½	10½	1½	2½	8½	7½	7½	22	14½	14	12	7½	9½	6	14	17½
14	14	7	13	20	30	19	4½	7½	1½	4½	14	14	12	1½	2½	10	9	8½	25½	16½	16½	14½	8½	11½	6½	16½	20½

#### WA HEAD OFFICE

Unit 1 / 45 Inspiration Drive WA 6065  
 ☎ (08) 9303 4966 📠 (08) 9303 4977  
 📧 info@chainanddrives.com.au

#### NSW HEAD OFFICE

Unit 7 / 70 Holbeche Road Arndell Park NSW 2148  
 ☎ (02) 9674 8611 📠 (02) 9674 8363  
 📧 salesnsw@chainanddrives.com.au

[www.chainanddrives.com.au](http://www.chainanddrives.com.au)